



TECHNICAL REPORT

**Determination of the resistance  
to the passage of chloride ions  
through a waterproofing layer  
subjected to indentation  
by aggregate**

TR 022  
Edition November 2007

# **EOTA TECHNICAL REPORT**

**Determination of the resistance to the passage of chloride ions  
through a waterproofing layer subjected to indentation by aggregate**

TR 022

Edition November 2007

**EUROPEAN ORGANISATION FOR TECHNICAL APPROVALS**

# **Determination of the resistance to the passage of chloride ions through a waterproofing layer subjected to indentation by aggregate**

## ***Foreword***

EOTA Technical Reports are developed as supporting reference documents to European Technical Approval Guidelines (ETAG) and can also be applicable to a Common Understanding of Assessment Procedures (CUAP), an EOTA Comprehension Document or an European Technical Approval, as far as reference is made therein.

EOTA Technical Reports go into detail in some aspects and express the common understanding of existing knowledge and experience of the EOTA Bodies at a particular point in time.

Where knowledge and experience is developing, especially through approval work, such reports can be amended and supplemented.

When this happens, the effect of the changes upon the European Technical Approval Guidelines will be laid down in the relevant Comprehension Documents, unless the European Technical Approval Guideline is revised.

## **1 Scope**

This EOTA Technical Report specifies a method for determining the resistance to the passage of chloride ions through a liquid

applied bridge deck waterproofing membrane following simulated indentation by hot aggregate resulting from the compaction of a coarse bituminous mixture.

## **2 Principle**

Specimens of membrane bonded to concrete substrate are subjected to simulated aggregate indentation. The retention of waterproofing properties following the aggregate indentation is determined by exposing the specimens to a saturated solution of sodium chloride for a defined period of time. The concrete is sampled and the chloride ion concentration is determined by means of chloride specific electrodes. The level of chloride ions passing through the waterproofing system is determined by reference to the original chloride ion concentration of the concrete prior to exposure.

## **3 Apparatus**

3.1 Aggregate indentation apparatus complying with Figure 2 incorporating a heating element and capable of maintaining a temperature at the tip of the indenter of 125°C.

3.2 Dial gauge suitable for measuring the thickness of the test specimens to  $\pm 0.1$  mm.

3.3 Concrete blocks for use as a standard substrate, prepared in accordance with Annex A.

3.4 Glass vessel to hold a saturated salt solution in contact with the waterproofing layer. The vessel shall be an open-ended cylinder with internal diameter  $100 \pm 2$  mm and of sufficient volume to hold at approximately 1.5 litres of salt solution, (see Figure 3).

3.5 Silicone sealing compound used to bond the glass vessel to the surface of the test specimen and to create a watertight seal.

3.6 Low speed grinding machine used to sample the upper surface of the concrete substrate

3.7 Balance capable of weighing to an accuracy of  $\pm 0.005$ g.

3.8 Ion specific electrodes or potentiometric titration apparatus capable of detecting chloride ion concentrations of solutions to an accuracy of  $\pm 0.01\%$  by weight of dry sample.

#### **4 Test specimens**

##### **4.1 Dimensions**

Specimens shall be prepared on concrete blocks ( $170 \pm 3\text{mm}$ ) by ( $170 \pm 3\text{mm}$ ) by ( $55 \pm 3\text{mm}$ ).

##### **4.2 Number of test specimens**

Three test specimens shall be tested.

##### **4.3 Preparation of the test specimen**

The test specimen shall comprise the complete assembled bridge-deck waterproofing system applied to the surface of the concrete blocks. Application of the waterproofing system shall be in accordance with the manufacturer's instructions.

##### **4.4 Curing and conditioning**

The test specimens shall be cured at a temperature of  $(23 \pm 2)^\circ\text{C}$  for the period prescribed by the manufacturer.

*Note: Include a min / max curing period?*

#### **5 Procedure**

##### **5.1 Simulated aggregate indentation at $125^\circ\text{C}$**

5.1.1 This conditioning is carried out to verify that the waterproofing system is suitable for directly overlaying with a coarse bituminous mixture i.e. without the need for a sand asphalt protection layer.

5.1.2 Three concrete blocks ( $170 \times 170 \times 55$ ) mm made in accordance with Annex A and with the system fully bonded shall be used for this test.

5.1.3 Before application of the system, the thickness of each concrete block shall be measured within the central 75 mm diameter test area at four separate locations using the template and dial gauge, (see Figure 1). The system shall then be applied and, when cured, the block re-measured at the same four

locations, identified using the template, to determine the total thickness.

5.1.4 The system thickness at each location shall be calculated by subtracting the measured concrete block thickness from the total thickness. The thickness at each location shall comply within  $\pm 10\%$  of the manufacturers declared nominal thickness. The mean thickness of the applied system shall also be calculated from the four results.

5.1.5 The resistance to aggregate indentation shall be carried out using the heated steel indenter in the shape of a truncated cone, with the cone angle at  $90^\circ$ , the diameter at the truncation 8 mm and the diameter at the base 25 mm (see Figure 2).

5.1.6 The specimens shall be pre-conditioned for at least 4 hours at  $(50 \pm 3)^\circ\text{C}$  and maintained at this temperature throughout the test procedure. The indenter shall be electrically heated to a temperature of  $(125 \pm 3)^\circ\text{C}$ . Indentation shall be produced by forcing the truncated end of the indenter into the system using a test machine that can apply and measure the force and displacement simultaneously. The test shall be carried out at a temperature of  $(50 \pm 3)^\circ\text{C}$ .

5.1.7 Indentations shall be made at each of the four locations where the thickness measurements were made. Each indentation shall be made by driving the indenter into the system at a rate of 5 mm per minute. Indentation shall be stopped when the force applied reaches 1000N. The load shall be removed at the same rate. The samples shall then be allowed to recover by conditioning at  $(23 \pm 2)^\circ\text{C}$  for 24 hours.

5.1.8 The recovered thickness at each location shall be measured using the template and dial gauge. Individual thickness measurements shall then be determined by subtracting the concrete block thickness from the recovered thickness.

5.1.9 Indentation after the recovery period shall not exceed 50% of the initial thickness of the applied system.

5.1.10 The chloride ion test shall then be carried out in accordance with clause 5.2.

## 5.2 Determination of the resistance to the passage of chloride ions.

5.2.1 Following the simulated aggregate indentation, the resistance to the passage of chloride ions shall be determined as follows:

5.2.2 The glass vessel shall be bonded to the upper surface of the test specimen using a silicone sealant (or similar sealing compound), such that a watertight seal is created, and the sealant shall be allowed to cure (see Figure 3).

*Note: Care must be taken to ensure that there is no possibility that the sealant used will leach chloride ions into the concrete.*

5.2.3 The assembled test specimen shall be placed on a level surface in a temperature controlled environment at  $(23\pm 2)^{\circ}\text{C}$ . A saturated sodium chloride solution (approximately 1.5 litres) shall be added to the glass vessel so that it is in full contact with the upper surface of the waterproofing membrane. The original level of the solution shall be marked on the glass vessel for reference. The level shall be between 25mm to 35 mm below the top of the vessel. The open end of the glass vessel shall be loosely covered to minimise evaporation of the solution.

5.2.4 The assembled test specimen shall be stored in the temperature-controlled environment for a period of (28, -0, +0.5) days. Throughout this period the test specimen shall be examined periodically for signs of loss of solution by penetration, absorption or by 'wicking' (i.e. horizontal movement to the edge of the test specimen at interfaces). Any such phenomena shall be recorded.

5.2.5 At the end of the 28-day period any drop in the level of the solution shall be recorded to the nearest millimetre. The salt solution shall be carefully poured away, the glass vessel removed and the surface of the test specimen shall be washed with potable water to remove all traces of salt solution. Care shall be taken during this process to avoid accidental contamination of the concrete block.

5.2.6 The waterproofing layer(s) shall then be carefully removed to expose the surface of concrete substrate. The blocks shall be dried in a ventilated oven at  $(103\pm 2)^{\circ}\text{C}$  for approximately 16 hours

5.2.7 The surface of the concrete shall be sampled by means of low speed grinding. Grinding shall cover as much of the 100 mm

diameter exposure area as possible and shall not exceed 3 mm in depth. A 5 to 10g sample of powdered concrete shall be collected and thoroughly mixed to ensure a homogenous sample.

5.2.8 A 0.5 to 3.0g sample of the powdered concrete shall be used for each of two determinations. The chloride ion concentration of the sample shall be determined by means of chloride ion specific electrodes or by potentiometric titration.

5.2.9 The procedure shall be repeated on the other two test specimens.

## 6 Expression of results

6.1 The average value of the two determinations per test specimen shall be taken as the chloride ion concentration of the sample block expressed as % chloride by weight of dry sample.

6.2 The measured chloride ion concentration of each block shall be compared to the background chloride ion concentration of the reference concrete block.

## 7 Test report

The test report shall include at least the following information:

- a) all details necessary to identify the product tested;
- b) a reference to this Technical Report and any deviation from it;
- c) a description of the test specimens, including dimensions, curing and conditioning;
- d) test conditions;
- e) The measured chloride ion concentrations relating to each test specimen;
- f) the background chloride ion concentration of the substrate blocks;
- g) the mean, and individual, changes in chloride ion concentration;

- h) the dates of delivery and preparation of specimens;
- i) the date of tests;
- j) all operating details not specified in this Technical Report, including any deviations or other incidents likely to have affected the results;

## Annex A

### Preparation of concrete blocks

A.1 Concrete blocks (170 × 170 × 55) mm shall be prepared using concrete with the following mix proportions:

1 part	Portland Cement	– EN 197-1 CEM I
2 parts	Sand	– EN 1260
3.5 parts	10 mm aggregate	– EN 1260
0.5 parts	water (maximum)	– EN 1008

A.2 The concrete shall be levelled and screeded to produce a uniform surface. When the concrete has sufficiently hardened and the bleed water evaporated the surface shall be trowelled to produce a hard dense surface free from screed marks and exposed aggregate. Finally the surface shall be lightly textured with a wooden float or equivalent.

A.3 Blocks shall be removed from the moulds after 24 hours and stored under wet hessian and polyethylene sheets under ambient laboratory conditions for a further six days. Blocks shall then be stored, uncovered, for a further 21 days. All blocks shall be cured and thoroughly dry before use.

A.4 A minimum of two blocks from each batch prepared shall be selected at random. The chloride ion concentration of these reference blocks shall be determined in accordance with section 5.2 of this Technical Report. The mean of these results shall be taken as the background chloride ion concentration for all blocks prepared at the same time.

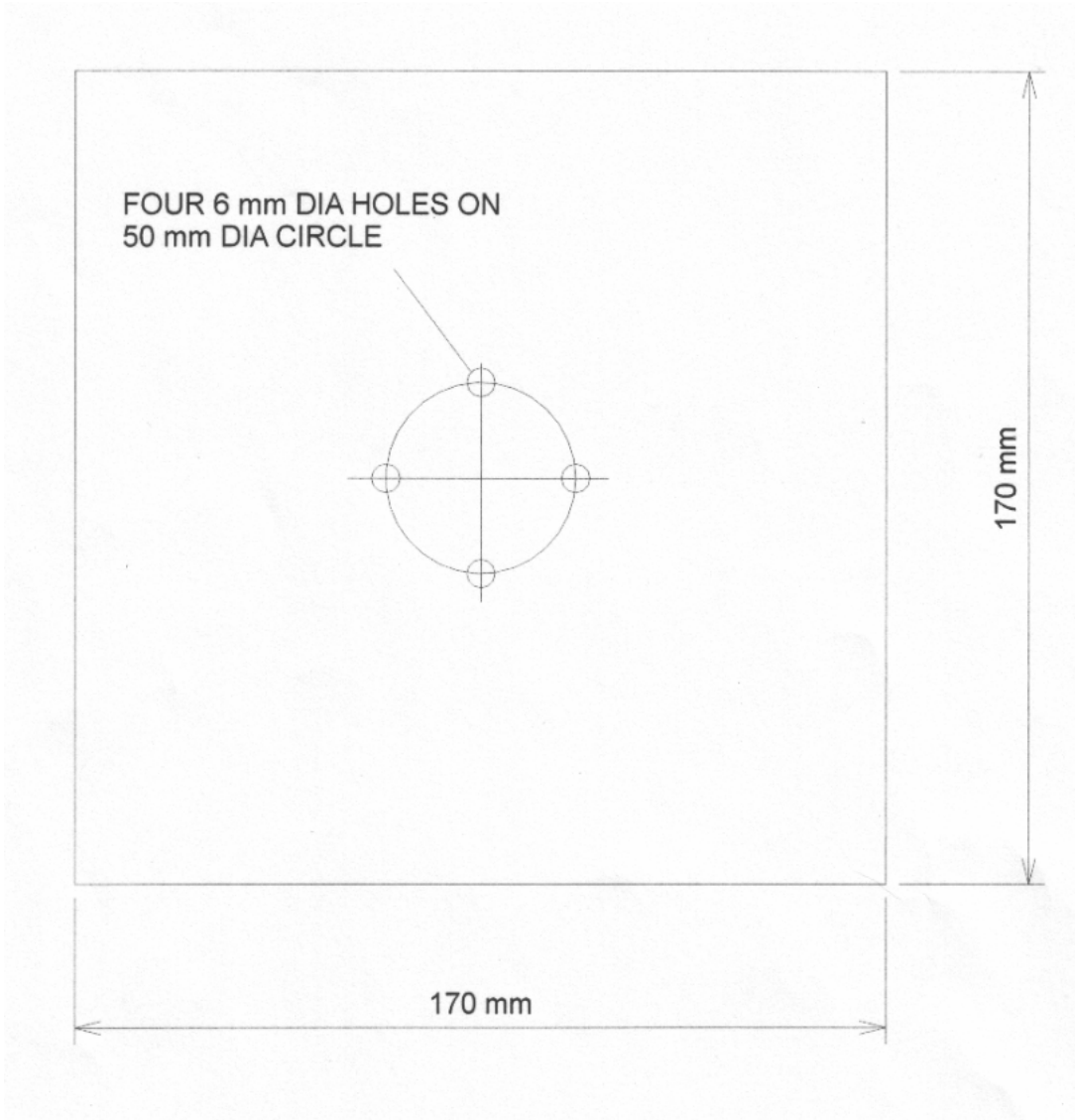

**Figure 1 Aggregate indentation template**



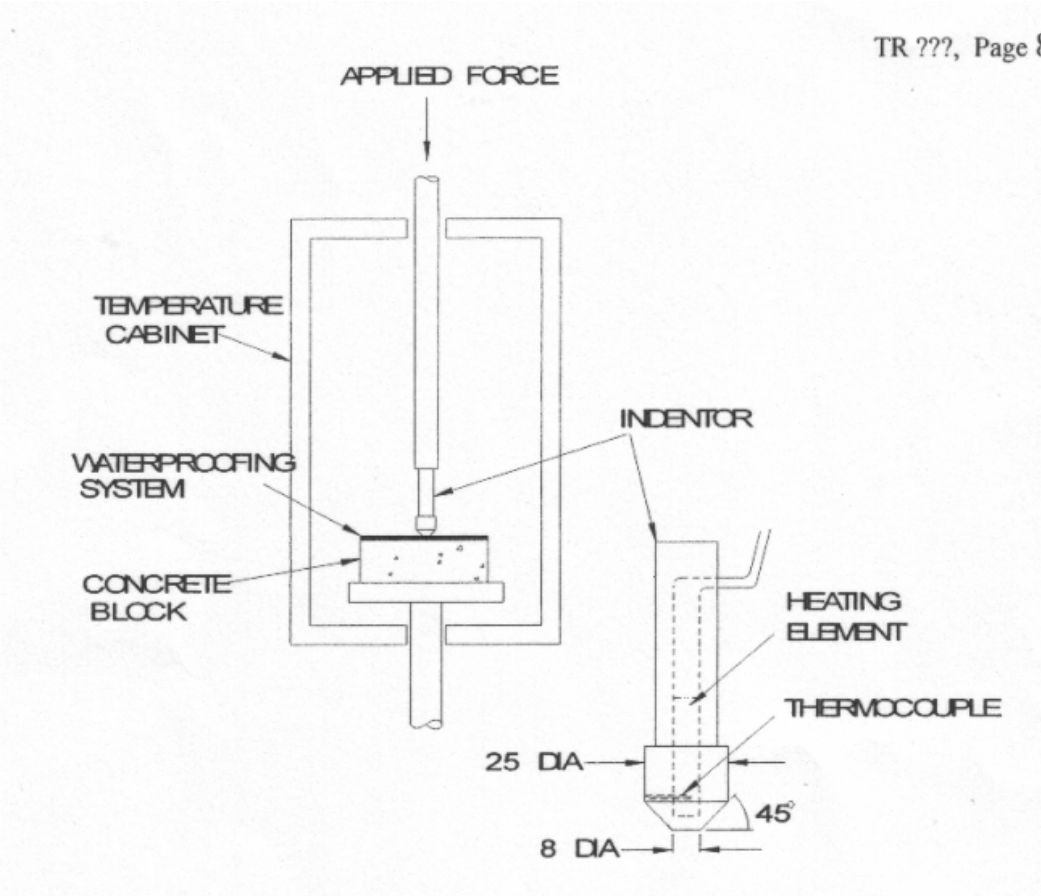

All dimensions in mm

Figure 2 Aggregate Indentation Apparatus

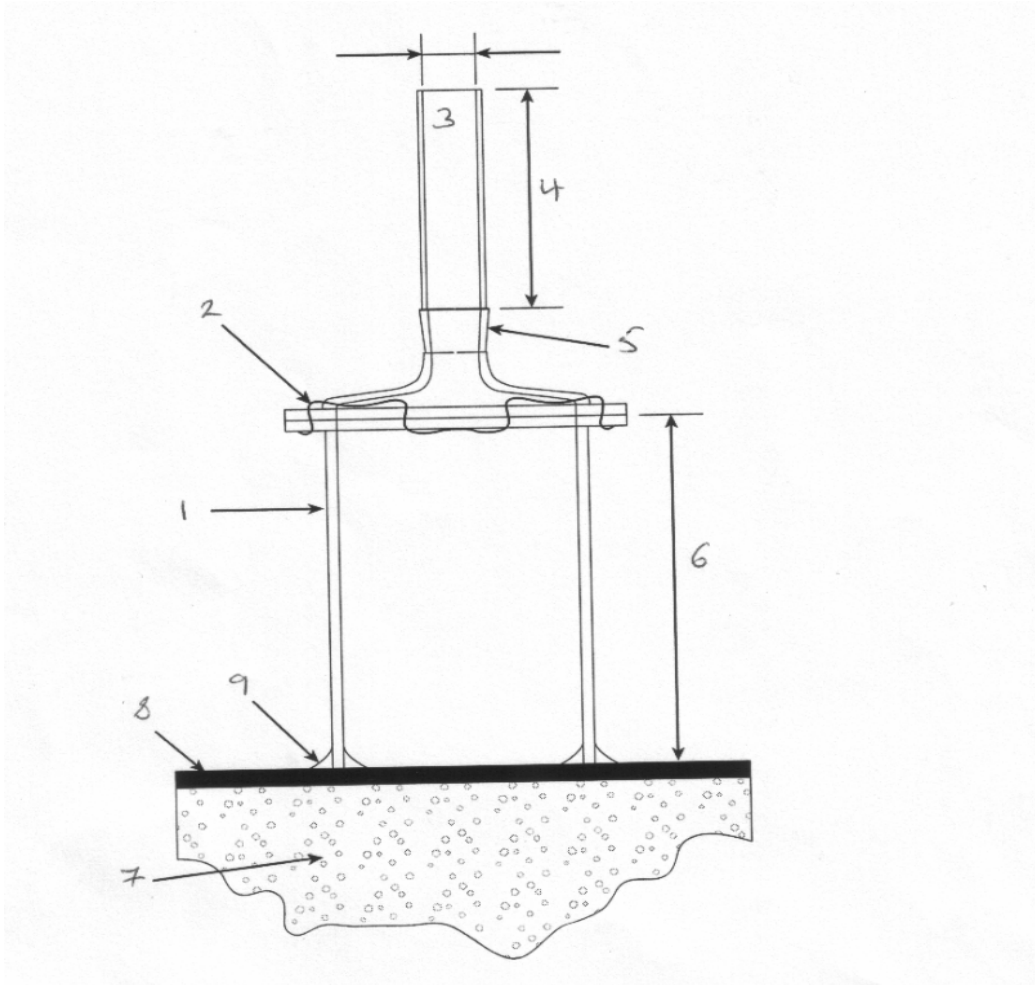

1. Glass cylinder Internal diameter  $100 \pm 2\text{mm}$
2. Wire Clamp
3. 24mm Internal diameter
4. 105mm
5. 29/32 mm diameter
6. 160mm
7. Concrete block
8. Waterproofing System
9. Sealing Compound

**Figure 3 Glass vessel sealed to surface of waterproofing system**