



TECHNICAL REPORT

Design of fasteners for facade panels made
of natural stone
(except slate)

TR 062
July 2018

Contents

1	SCOPE OF THE TECHNICAL REPORT	3
1.1	Fastener	3
1.2	Façade panel	3
1.3	Type and direction of load	4
1.4	Specific terms used in this TR.....	4
2	DESIGN AND SAFETY CONCEPT.....	5
2.1	Design concept	5
2.2	Ultimate limit state	5
3	STATIC ANALYSIS	6
3.1	General.....	6
3.2	Loads acting on fastener.....	7
3.2.1	Determination of the fastener loads at the fixing points of the façade panel.....	7
3.2.2	Determination of the fastener loads on the fixing points of reveal angle.....	7
3.2.3	Shear loads with or without lever arm	7
3.3	Determination of decisive bending moment in the façade panel	8
3.3.1	Simplified calculation of the moment from wind load	8
3.3.2	Determination of moments by Finite-Element-Method	9
3.3	Verification against corner breakage of façade panels with reveal panels	10
3.4	Determination of the decisive bending moment in the reveal panel	10
4	ULTIMATE LIMIT STATE.....	11
4.1	General.....	11
4.2	Design method of fasteners.....	11
4.2.1	Resistance to breakout or pull-out failure under tension loads or compression load.....	11
4.2.2	Resistance to breakout or pull-out failure under shear loads.....	12
4.2.3	Resistance to breakout or pull-out failure under combined tension and shear load	13
4.2.4	Resistance to steel failure under tension loads or compression load.....	14
4.2.5	Resistance to steel failure under shear loads	14
4.2.6	Resistance to steel failure under combined tension and shear load	15
5	DETERMINATION OF CHARACTERISTIC VALUES OF NATURAL STONE FAÇADE PANELS ACCORDING TO EN 1469	16
5.1	General.....	16
5.2	Flexural strength ($\sigma_{u5\%}$, σ_{um}).....	16
5.3	Flexural strength after weathering ($\sigma_{um,exp}$)	16
5.4	Ultimate tension load of the fastener ($N_{u5\%}$).....	17
5.5	Ultimate shear load of the fastener ($V_{u5\%}$)	17
6	REFERENCE DOCUMENTS.....	19

1 SCOPE OF THE TECHNICAL REPORT

This Technical Report (TR) provides design methods for fasteners with a European Technical Assessment (ETA) on basis of EAD 330030-00-0601 [1]. This document relies on characteristic resistances and distances which are stated in the ETA and referred to in this TR.

The design method applies to the design of fasteners in façade panels made of natural stone (except slate) according to EN 1469 [2].

Note: In comparison with other materials, the natural stone material could be different from the tested material in the ETA.

The proof of local transmission of the façade panel loads into the fastener is delivered by using the design methods described in this document.

The façade panels, the clamps, the subframe components and any other façade system component are not covered by this Technical report.

Proof of transmission of fastener loads to the clamps and the façade substructure as well as to the building shall be done by the engineer of the construction works.

1.1 Fastener

The essential characteristics of the fastener (characteristic values of resistance, edge distances and spacing) are given in the relevant ETA.

For different natural stone material, than given in the ETA (trade name and country of origin according to EN 12440 [11] and flexural strength $\sigma_{5\%}$), the characteristic resistances may be determined according to Section 5 if characteristic resistances of the fastener are given in the ETA for the same Stone group (see Table 1.1). If characteristic resistances for Stone Group I and IV are given in the ETA also characteristic resistances for Stone group II and II may be determined.

1.2 Façade panel

The façade panels made of natural stone (except slate) in which the fastener are to be anchored shall correspond with the construction rules for natural stone, such as EN 1469 [2], EAD 330030-00-0601 [1] and the relevant national regulations.

Façade panels made of natural stone are divided into different Stone groups according to following Table.

Table 1.1 Stone groups for façade panels made of natural stone

	Stone group	Natural stone type	Boundary conditions
I	High quality intrusive rocks (plutonic rocks)	Granite, granitite, tonalite, diorite, monzonite, gabbro, other magmatic plutonic rocks	None
II	Metamorphic rocks with „hard stone characteristics“	Quarzite, granulite, gneiss, migmatite	None
III	High quality extrusive rocks (volcanic rocks)	Basalt and basaltic lava without harmful ingredients (like sun burner basalt)	Minimum density ρ : basalt: 2,7 kg/dm ³ basaltic lava: 2,2 kg/dm ³
IV	Sedimentary rocks with „hard stone characteristics“ ⁽¹⁾	Sandstone, limestone and marble	Minimum density ρ : sandstone: 2,1 kg/dm ³

¹⁾ For façade panels made of natural stones with planes of anisotropies, the difference between the flexural strength determined parallel to the planes of anisotropy and perpendicular to the edges of the planes of anisotropy shall not be more than 50 %.

1.3 Type and direction of load

This Technical Report applies only to fasteners subject to static or quasi-static actions in tension, shear or combined tension and shear or bending. This Technical Report covers applications only external wall claddings are subject to static or quasi-static actions.

For horizontal and inclined panels up to 85° from horizontal, an increase factor shall be taken into account due to the reduction in flexural strength, the resistance to breakout of the fastener due to the effects of vibration and dynamic loads in case of quasi-static actions. For static verification, the dead load of the panel shall be multiplied by the increase factor 1,4.

1.4 Specific terms used in this TR

The notations and symbols frequently used in this TR are given below. Further particular notation and symbols are given in the text.

Façade panels	=	plates usually used for external wall claddings ventilated at rear
Fastener	=	product for fixing the façade panel to the substructure
a	=	spacing – distance between fasteners
a_r	=	edge distance – distance of an fastener to the panel edge
A_s	=	stressed cross section of steel element (smallest cross section in the area of load transfer applies)
E_d	=	design value of action
F	=	force in general
$h = h_{nom}$	=	nominal thickness of panel
H	=	smaller length of the façade panel
h_1	=	nominal thickness of panel
L	=	greater length of the façade panel
m	=	moment
$m_{EK,w}$	=	moment from wind load (see section 3.3.1)
$m_{EK,gL}$	=	moment from dead load reveal (see section 3.3.2)
$m_{EK,wL}$	=	moment from wind load reveal (see section 3.3.3)
N	=	normal force (+N = tension force)
N_{Rd}	=	design value of resistance under tension
N_{Rk}	=	characteristic fastener resistance under tension
R_d	=	design value of resistance
R_k	=	characteristic resistance
V	=	shear force
V_{Rd}	=	design value of resistance under shear load
V_{Rk}	=	characteristic fastener resistance under shear load
X	=	limit value in a trilinear function
Y	=	exponent in an exponential function
α_{exp}	=	reduction factor for exposure
γ_M	=	partial safety factor for material
ρ	=	the density of façade panel according to EN 1936 [3] taking into account the water absorption under atmospheric pressure according to EN 13755 [4].
ν	=	poisson's ratio
σ_{um}	=	mean value of flexural strength of facade panel
$\sigma_{um,exp}$	=	flexural strength of facade panel after weathering

2 DESIGN AND SAFETY CONCEPT

2.1 Design concept

The design of anchorages shall be in accordance with the general rules given in EN 1990:2002 + A1:2005 / AC:2010 [8]. It shall be shown that the value of the design actions E_d does not exceed the value of the design resistance R_d .

$$E_d \leq R_d \quad (1)$$

Actions to be used in design may be obtained from national regulations or in the absence of them from the relevant parts of EN 1991:2002 + AC 2009 [5].

The partial safety factors for actions may be taken from national regulations or in the absence of them according to EN 1990:2002 + A1:2005 / AC:2010 [8].

The design resistance is calculated as follows:

$$R_d = R_k / \gamma_M \quad (2)$$

2.2 Ultimate limit state

The design resistance is calculated according to Equation (2).

Failure of the façade panel

In absence of other national regulations the following partial safety factor for façade material is recommended:

$$\gamma_M = 1,8 \cdot \gamma_1 \cdot \gamma_2 \quad (3)$$

$$\begin{aligned} \gamma_1 &= 1,25 && \text{if the tests for determination of } N_{u5\%}, V_{u5\%} \text{ and } \sigma_{u5\%} \text{ date back more than 2 years} \\ &= 1,00 && \text{if the tests for determination of } N_{u5\%}, V_{u5\%} \text{ and } \sigma_{u5\%} \text{ date back less than 2 years} \end{aligned}$$

Note: Due to the alterability of natural stone the actual strength values of the material installed may deviate from the declared values. The partial safety factor γ_1 considers at which date the characteristic values of the material have been determined.

$$\gamma_2 = 1 + (v[\%] - 20) \cdot 0,03 \geq 1,0$$

with v = coefficient of variation, determined from the declared values of standard deviation and average value

Failure (rupture) of the fastener (steel failure)

Tension loading:

$$\gamma_{Ms} = \frac{1,2}{f_{yk} / f_{uk}} \geq 1,4 \quad (4a)$$

Shear loading of the fastener with and without lever arm:

$$\begin{aligned} \gamma_{Ms} &= \frac{1,0}{f_{yk} / f_{uk}} \geq 1,25 && f_{uk} \leq 800 \text{ N/mm}^2 && \text{and} && f_{yk} / f_{uk} \leq 0,8 && (4b) \\ \gamma_{Ms} &= 1,5 && f_{uk} > 800 \text{ N/mm}^2 && \text{or} && f_{yk} / f_{uk} > 0,8 \end{aligned}$$

Alternatively the value γ_{Ms} can be taken from the ETA.

If γ_{Ms} or f_{yk} and f_{uk} or the fastener strength class is not given in the ETA following value $\gamma_{Ms} = 2,5$ can be used.

3 STATIC ANALYSIS

3.1 General

The substructure is constructed such that the façade panel are fixed technically strain-free via three loose bearings and one fixed bearing (see Figure 3.1). Two fixing points of the façade panel are designed such that they are able to carry the dead load of the façade panel. When using agraffes on horizontal load-bearing profiles the fixing points of a façade panel situated horizontally at the same height are fastened in each case to the same load-bearing profile.

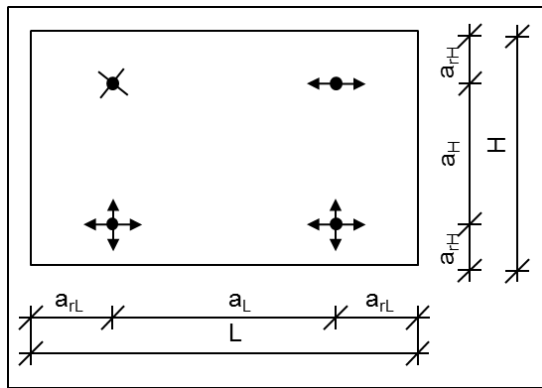

Legend:

- a_{rL}, a_{rH} = edge distance – distance of an fastener to the panel edge
- a_L, a_H = spacing – distance between fasteners
- L = greater length of the façade panel
- H = smaller length of the façade panel
- = fixed point (fixed bearing)
- = horizontal skid (loose bearing)
- = horizontal and vertical skid (loose bearing)

Figure 3.1

It shall be distinguished between a uniform and a non-uniform bearing. The geometrical symmetrical execution signifies for example the configuration analogous to Figure 3.2. If additionally to the geometrical symmetrical execution uniform horizontal or vertical profiles are used, it can be deemed to be a uniform bearing.

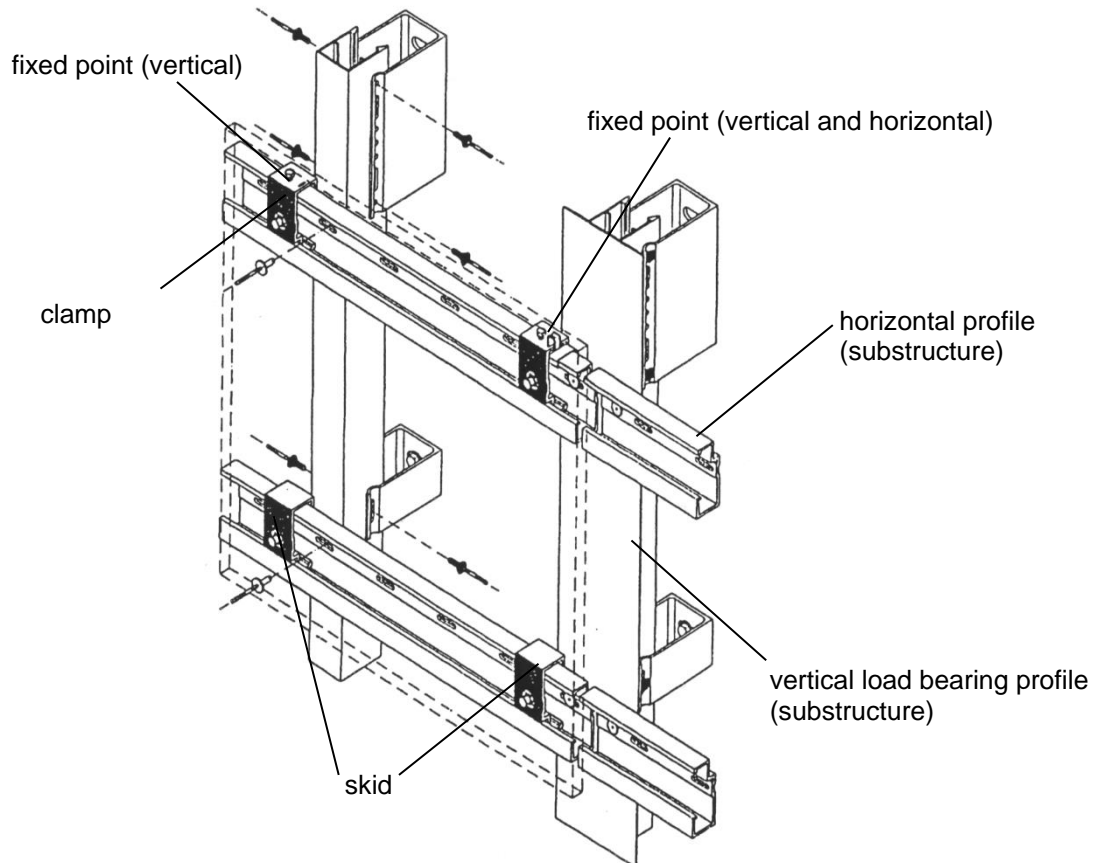

Figure 3.2 Example of a substructure

3.2 Loads acting on fastener

Distribution of loads acting on fasteners shall be calculated according to the theory of elasticity.

For steel failure under tension and shear and for pull-out failure under tension the load acting on the highest loaded fastener shall be determined.

In case of edge failure of façade panel the shear load is assumed to act on the fastener(s) closest to the edge.

3.2.1 Determination of the fastener loads at the fixing points of the façade panel

The determination of the fastener loads depends on the type of bearing of the façade panel. The fastener loads are to be determined for each fixing point from the load proportions wind and dead load of the façade panel as well as from the load proportions wind and dead load of the reveal panel.

The dead load of the façade and reveal panels for relevant material is to be determined from the density according to EN 1936 [3] taking into account the water absorption under atmospheric pressure according to EN 13755 [4].

In case of uniform bearing the determination of the fastener loads shall be based on a 4-point-fixing. Otherwise, a calculation taking into account the elasticity of the substructure is required.

In case of a non-uniform bearing the determination of the fastener loads can be based in a simplified way on a 3-point-fixing (failure of one fastener). Otherwise, a calculation taking into account the elasticity of the substructure is required.

Load transfer of the dead load must always be carried out with two load-bearing fasteners.

3.2.2 Determination of the fastener loads on the fixing points of reveal angle

The fastener loads at the reveal angle are to be determined from the load proportions wind and dead load of the reveal panel.

Note:

If the edge distance given in the ETA $a_r = 50$ mm and the fasteners are installed with an edge distance $40 \text{ mm} \leq a_r < 50$ mm, the characteristic load-bearing capacity for tension load shall be reduced by the factor 0,9.

3.2.3 Shear loads with or without lever arm

In addition to the actions from dead load and wind load the following actions shall be considered as permanent loads in direction to the fastener axes.

In case of flush fixing of the fastener (see Figure 3.3) and when using horizontal load-bearing profiles: due to torsion of the load-bearing profile resulting from dead load of the façade panel the following load $N_{v,Ek}$ shall be considered:

$$N_{v,Ek} = V_{Ek} \cdot e/z \tag{5}$$

with V_{Ek} = shear load due to dead load of the façade panel
 e = distance between surface of the panel and shear centre point (M) of the clamp
 z = distance between tension and compression forces due to the torsion moment
 (see also Figure 3.3)

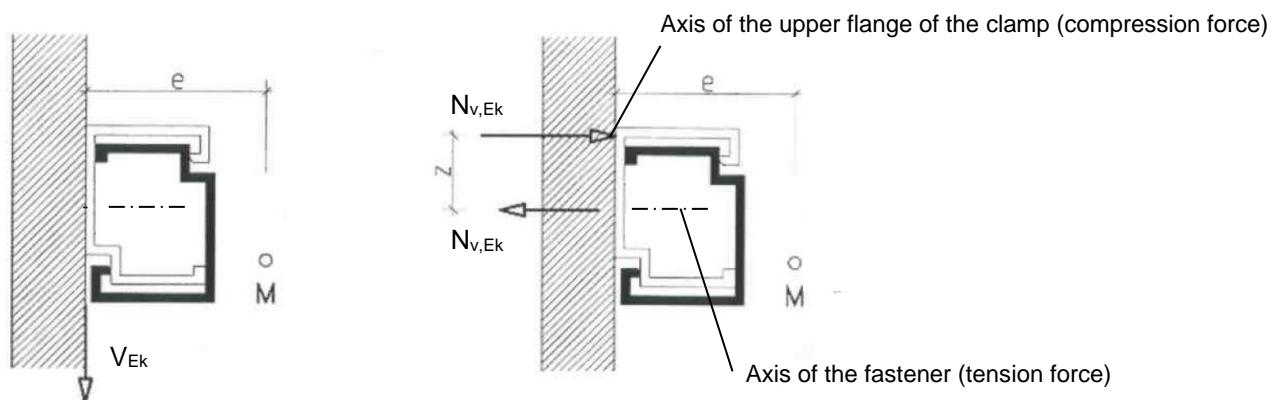

Figure 3.3: torsion of horizontal load-bearing profiles resulting from dead load of the façade panels

3.3 Determination of decisive bending moment in the façade panel

The determination of bending moments depends on the type of bearing of the façade panel. In case of uniform bearing and non-uniform bearing the decisive bending moment shall be calculated according to Equation (6). For the decisive bending moment the wind load and dead load of the façade panel are to be taken into account. In case of façade panel with reveal panels the wind load and dead load of the reveal panels shall be taken into account.

The decisive bending moment results from:

$$m_{Ed} = (m_{EK,w} + m_{EK,wL}) \cdot \gamma_F + m_{EK,gL} \cdot \gamma_G \tag{6}$$

- with: $m_{EK,w}$ = moment from wind load
- $m_{EK,gL}$ = moment from dead load reveal
- $m_{EK,wL}$ = moment from wind load reveal
- γ_F = partial safety factor for wind loads
- γ_G = partial safety factor for dead loads

3.3.1 Simplified calculation of the moment from wind load

The moment from wind load may be determined according to Equation (7a) or (7b).

In case of uniform bearing:

$$m_{EK,w} = \alpha_{1a} \cdot w \cdot L \cdot H \tag{7a}$$

In case of non-uniform bearing:

$$m_{EK,w} = \alpha_{1b} \cdot w \cdot L \cdot H \tag{7b}$$

- with: w = wind load according to EN 1991-1-4 [5]
- $L, H, \alpha_{1a}, \alpha_{1b}$ see Figure 3.4

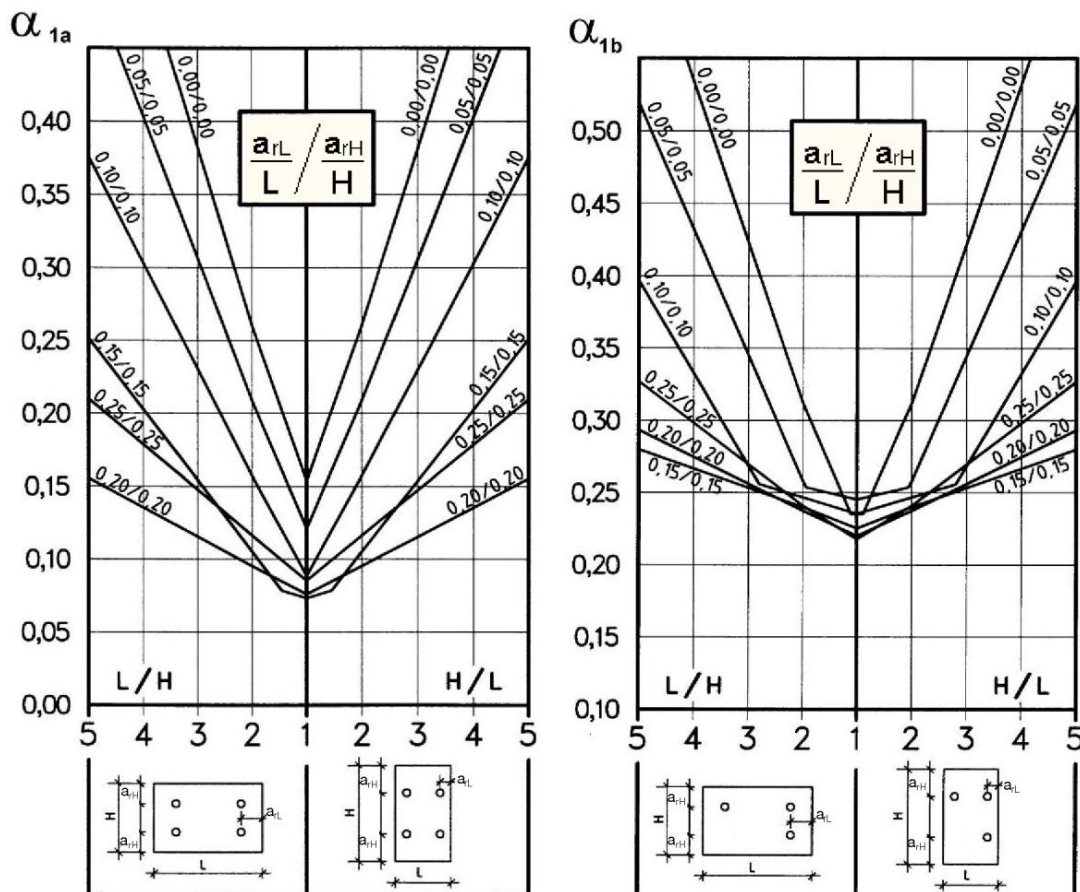

Figure 3.4 Moments coefficient for wind loads

3.3.2 Determination of moments by Finite-Element-Method

For simple symmetrical arrangement of the fixing points and to determine the additional internal forces from reveal panels on the facade panel, the internal forces can be determined by the finite element method. Proof of the local load transfer of the reveal loads by the angles can be made by proving the corner breakage.

Specifications for static calculation:

1. The calculation is to be performed linearly elastic. The chosen system shall be able to reproduce the stress and deformation state as well as the bearing forces of the facade panels with sufficient accuracy.
2. The façade panels are to be idealized with their actual dimensions (size and thickness) as panel elements. The support points are to be idealized as rotatable restraint (hinge).
3. The modelling of the façade panel is to be calibrated on the basis of the following points:
 - For the panel sizes specified in Figures 3.5 and 3.6, the support moment m_s shall be calculated for the respective loads. The dimensions of the finite elements in the support area ($> 10 h$) shall be identical. The calculated support moments shall not exceed the values given in Figure 3.5 or Figure 3.6 (a tolerance of 5% is allowed). The modeling can be optimized by varying the element size in the support area. The selected element size in the support area must be applied to all panels.
 - The calibration is carried out with a modulus of elasticity $E = 50000 \text{ N/mm}^2$ and a Poisson's ratio $\nu = 0,2$. The specified loads are to be used without safety factors.
 - Between fastener axis and panel edge at least 2 elements are to be arranged.
4. On the basis of the calibrated model, panels of any geometry, which are supported on at least three fasteners, can be verified.

System data for model calibration:

Panel length	L	=	2,00 m
Panel width	H	=	1,00 m
Edge distance x-direction	a_{rL}	=	0,40 m
Edge distance y-direction	a_{rH}	=	0,20 m
Panel thickness	h	=	30 mm
Loading	q	=	1,0 kN/m ²

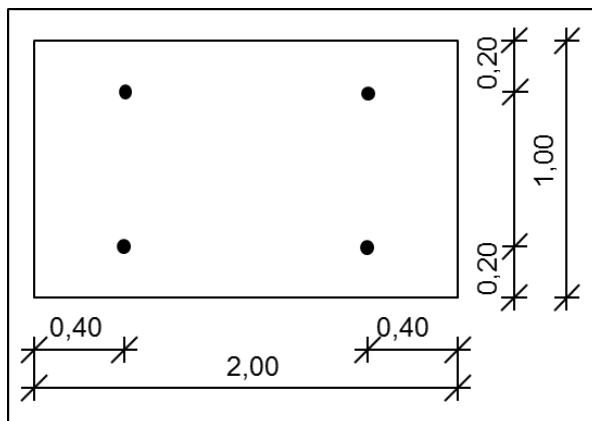

Figure 3.5: System 1 ($m_s = 0,19 \text{ kNm/m}$)

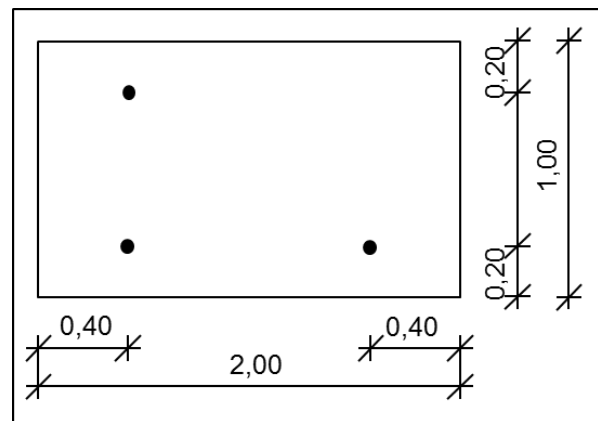

Figure 3.6: System 2 ($m_s = 0,48 \text{ kNm/m}$)

The calibration is carried out with System 1 or System 2.

3.3 Verification against corner breakage of façade panels with reveal panels

When fixing the reveal panels on the façade panel the verification against edge failure due to loads on the reveal angle shall be carried out additionally both for reveal panel and façade panel.

The decisive bending moment shall be determined according to Equation (10).

$$m_{Ed} = \alpha_5 \cdot F_{Ed,L} \tag{10}$$

with: $\alpha_5 = 0,575 - 1,5 \cdot b_r \geq 0,2$

$F_{Ed,L}$ = decisive fastener load on reveal angle

$b_r = b_{rL}$ or b_{rH} [m] (edge distance to reveal front according to Figure 3.7)

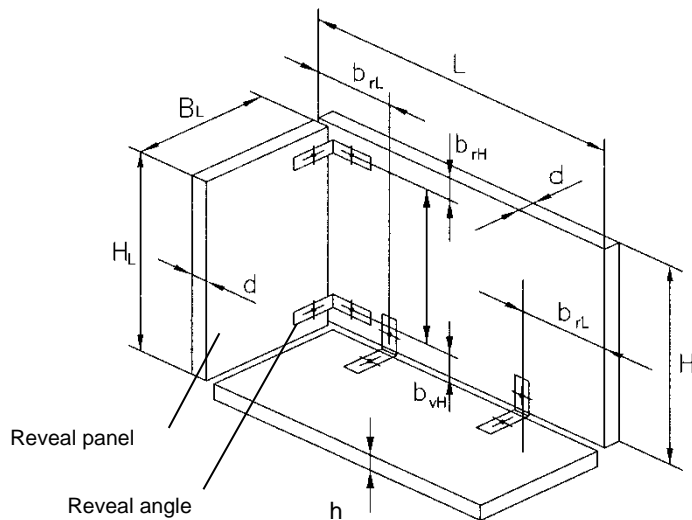

Figure 3.7 Dimensions of the natural stone panel

3.4 Determination of the decisive bending moment in the reveal panel

For the determination of the decisive bending moment the reveal panel shall be calculated parallel to the façade plane as a beam in bending and perpendicular to the façade plane as a cantilever.

Special case: lintel reveal

For the determination of the decisive bending moment the dead loads shall be increased by the factor 1,4.

4 ULTIMATE LIMIT STATE

4.1 General

For the design of anchorages in the ultimate limit state the design of fasteners according to Section 4.2 and the design of façade panels according to Section 4.3 are required.

For different natural stone material, than given in the ETA of the fastener, the factor α_{exp} shall be determined (for consideration of deterioration of strength due to exposure, e.g. freeze-thaw-stress, moisture penetration):

$$\alpha_{exp} = 1,25 \cdot \frac{\sigma_{um,exp}}{\sigma_{um}} \leq 1,0 \quad \text{generally} \quad (11a)$$

$$\alpha_{exp} = 1,00 \cdot \frac{\sigma_{um,exp}}{\sigma_{um}} \leq 1,0 \quad \text{marble} \quad (11b)$$

with: α_{exp} = factor for consideration exposure (freeze-thaw-stress, moisture penetration)
 $\sigma_{um,exp}$ = according to Section 5.3
 σ_{um} = according to Section 5.2

Alternatively the following conservative standard values for α_{exp} may be used:

$\alpha_{exp} = 1,00$ for natural stones of stone group I and II and III
 $\alpha_{exp} = 0,90$ for limestone without marble
 $\alpha_{exp} = 0,50$ for sandstone

4.2 Design method of fasteners

4.2.1 Resistance to breakout or pull-out failure under tension loads or compression load

Following Equation shall be fulfilled:

$$\frac{N_{Ed}}{N_{Rd}} \leq 1,0 \quad (12)$$

with: N_{Ed} = design value of existing fastener tension load / compression load
 N_{Rd} = design value of fastener load-bearing capacity under tension or compression load according to Equation (13) or Equation (14)

For tension load:

$$N_{Rd} = \frac{N_{Rk}}{\gamma_M} \quad (13)$$

with: N_{Rk} = according to ETA or for different natural stone material according to Equation (17)
 γ_M = according to Equation (3)

Special case reveal panel:

If the edge distance given in the ETA $a_r = 50$ mm and the fasteners are installed with an edge distance $40 \text{ mm} \leq a_r < 50$ mm, the characteristic load-bearing capacity for tension load shall be reduced by the factor 0,9.

For compression load (only for stand-off fixing):

$$N_{Rd} = k \cdot \frac{N_{Rk}}{\gamma_M} \quad (14)$$

with: N_{Rk} = according to ETA or for different natural stone material according to Equation (17)
 γ_M = according to Equation (3)

$$k = \left(\frac{h_r}{0,85 \cdot h_1} \right)^{1,5} \quad \text{for } 8 \text{ mm} \leq h_r \leq h_1 \quad (15)$$

$$k = 1,0 \quad \text{for } h_r > 0,85 \cdot h_1 \quad (16)$$

with: h_r = $h - h_1$
 h = thickness of façade panel
 h_1 = depth of drill hole

For different natural stone material than given in the ETA the characteristic load-bearing capacity N_{Rk} of the fastener is calculated as follows:

$$N_{Rk} = N_{u5\%} \cdot \alpha_{exp} \cdot f_{\sigma} \cdot \alpha_{TR} \quad (17)$$

with: $N_{u5\%}$ = according to Section 5.3
 α_{exp} = according to Equation (11) or the standard value given in 4.1
 α_{TR} = minimum α_{TR} given in the ETA
 f_{σ} = conversion factor according to Equation (18) if the tested flexural strength is higher than the value given in the Declaration of performance

$$f_{\sigma} = \frac{\sigma_{Rk,L}}{\sigma_{u5\%}} \leq 1,0 \quad (18)$$

with: $\sigma_{u5\%}$ = lower expectation value of flexural strength $\sigma_{u5\%}$ according to 5.2
 $\sigma_{Rk,L}$ = flexural strength given in the Declaration of performance according to EN 1469 [2]

4.2.2 Resistance to breakout or pull-out failure under shear loads

Following Equation shall be fulfilled:

$$\frac{V_{Ed}}{V_{Rd}} \leq 1,0 \quad (19)$$

with: V_{Ed} = design value of existing fastener shear load
 V_{Rd} = design value of fastener load-bearing capacity under shear load according to Equation (20)

$$V_{Rd} = \frac{V_{Rk}}{\gamma_M} \quad (20)$$

with: V_{Rk} = according to ETA or for different natural stone material according to Equation (21)
 γ_M = according to Equation (3)

For different natural stone material than given in the ETA the characteristic load-bearing capacity V_{Rk} of the fastener is calculated as follows:

$$V_{Rk} = V_{u5\%} \cdot \alpha_{exp} \cdot f_{\sigma} \cdot f_h \cdot \alpha_{TR} \quad (21)$$

- with:
- $V_{u5\%}$ = according to Section 5.3
 - α_{exp} = according to Equation (11) or the standard value given in 4.1
 - α_{TR} = minimum α_{TR} given in the ETA
 - f_{σ} = conversion factor according to Equation (18) if the tested flexural strength is higher than the value given in the Declaration of performance
 - f_h = factor according to Equation (22) if in the tests of $V_{Ru5\%}$ panel failure occurs

$$f_h = \frac{h_{min}}{h_{test}} \leq 1,0 \quad (22)$$

- with:
- h_{min} = minimum possible thickness according to tolerances
 - h_{test} = panel thickness in tests

4.2.3 Resistance to breakout or pull-out failure under combined tension and shear load

Equation (12), Equation (19) and at minimum one of the following Equations shall be fulfilled:

$$\frac{N_{Ed}}{N_{Rd}} + \frac{V_{Ed}}{V_{Rd}} \leq X \quad (23)$$

$$\left(\frac{N_{Ed}}{N_{Rd}}\right)^Y + \left(\frac{V_{Ed}}{V_{Rd}}\right)^Y \leq 1,0 \quad (24)$$

- with:
- N_{Ed} = design value of existing fastener tension load or compression load
 - N_{Rd} = design value of fastener load-bearing capacity under tension or compression load according to Equation (13) or Equation (15)
 - V_{Ed} = design value of existing fastener shear load
 - V_{Rd} = design value of fastener load-bearing capacity under shear load according to Equation (20)
 - X = limit value for trilinear curve for combined tension and shear load according to ETA for the same stone group if following conditions are fulfilled:
 $h \geq h(ETA)$, $h_s \geq h_s(ETA)$, $a_r \geq a_r(ETA)$, $\sigma_{5\%} \geq \sigma_{5\%}(ETA)$, $N_{Rk} \geq N_{Rk}(ETA)$
 and $V_{Rk} \geq V_{Rk}(ETA)$
 otherwise $X = 1,0$
 - Y = exponential value for exponential curve for combined tension and shear load according to ETA for the same stone group if following conditions are fulfilled:
 $h \geq h(ETA)$, $h_s \geq h_s(ETA)$, $a_r \geq a_r(ETA)$, $\sigma_{5\%} \geq \sigma_{5\%}(ETA)$, $N_{Rk} \geq N_{Rk}(ETA)$
 and $V_{Rk} \geq V_{Rk}(ETA)$
 otherwise $Y = 1,0$

4.2.4 Resistance to steel failure under tension loads or compression load

Following Equation shall be fulfilled:

$$\frac{N_{Ed}}{N_{Rd,s}} \leq 1,0 \quad (25)$$

with: N_{Ed} = design value of existing fastener tension load / compression load
 $N_{Rd,s}$ = design value of fastener load-bearing capacity under tension or compression load according to Equation (26)

$$N_{Rd,s} = \frac{N_{Rk,s}}{\gamma_{Ms}} \quad (26)$$

with: $N_{Rk,s}$ = according to ETA or according to Equation (27) or according to Equation (28)
 γ_{Ms} = according to Equation (4a)

$$N_{Rk,s} = A_s \cdot f_{uk} \quad (27)$$

with: A_s = stressed cross section of steel element (smallest cross section in the area of load transfer applies)
 f_{uk} = nominal characteristic steel ultimate strength of the fastener

In case of unknown A_s the value $N_{Rk,s}$ can be assumed according to following Equation:

$$N_{Rd,s} = \max. N_{Rk,ETA} \cdot \gamma_{Ms} / \gamma_M \leq 1,0 \quad (28)$$

with: $\max. N_{Rk,ETA}$ = maximum value N_{Rk} given in the ETA
 γ_M = according to Equation (3)
 γ_{Ms} = according to Equation (4a)

4.2.5 Resistance to steel failure under shear loads

Following Equation shall be fulfilled:

$$\frac{V_{Ed}}{V_{Rd,s}} \leq 1,0 \quad (29)$$

with: V_{Ed} = design value of existing fastener shear load
 $V_{Rd,s}$ = design value of fastener load-bearing capacity under shear load according to Equation (30)

$$V_{Rd,s} = \frac{V_{Rk,s}}{\gamma_{Ms}} \quad (30)$$

with: $V_{Rk,s}$ = according to ETA or according to Equation (31)
 γ_{Ms} = according to Equation (4b)

$$V_{Rk,s} = 0,5 \cdot A_s \cdot f_{uk} \quad (31)$$

with: A_s = stressed cross section of steel element (smallest cross section in the area of load transfer applies)
 f_{uk} = nominal characteristic steel ultimate strength of the fastener

In case of unknown A_s the value $V_{Rk,s}$ can be assumed according to following Equation:

$$V_{Rd,s} = \max. V_{Rk,ETA} \cdot \gamma_{Ms} / \gamma_M \leq 1,0 \quad (32)$$

with: $\max. V_{Rk,ETA}$ = maximum value V_{Rk} given in the ETA
 γ_M = according to Equation (3)
 γ_{Ms} = according to Equation (4b)

4.2.6 Resistance to steel failure under combined tension and shear load

Equation (25), Equation (29) and following Equation shall be fulfilled:

$$\left(\frac{N_{Ed}}{N_{Rd,s}}\right)^2 + \left(\frac{V_{Ed}}{V_{Rd,s}}\right)^2 \leq 1,0 \quad (33)$$

- with:
- N_{Ed} = design value of existing fastener tension load or compression load
 - $N_{Rd,s}$ = design value of fastener load-bearing capacity under tension or compression load according to Equation (26)
 - V_{Ed} = design value of existing fastener shear load
 - $V_{Rd,s}$ = design value of fastener load-bearing capacity under shear load according to Equation (30)

5 DETERMINATION OF CHARACTERISTIC VALUES OF NATURAL STONE FAÇADE PANELS ACCORDING TO EN 1469

5.1 General

For different natural stone material, than given in the ETA, the characteristic resistances may be determined according to this Clause (see also 1.1).

For natural stones with planes of anisotropy the position of the planes of anisotropy shall be considered (see Figure 5.1)

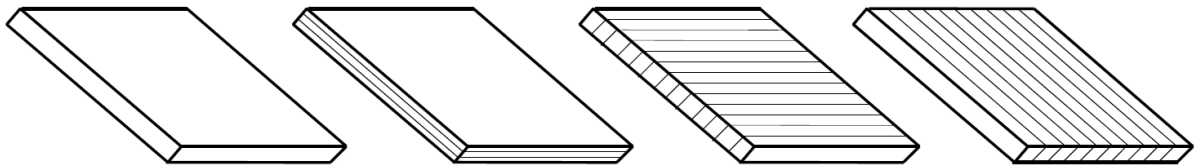

Figure 5.1

For evaluation and comparison of flexural strengths (e.g. after freeze-thaw-cycles or for the proof of the stability) the tests shall be performed always with the same test methods and the same dimensions of the test members.

5%-Fractile values are determined based on a confidence level of 75%, an unknown standard deviation and a lognormal distribution.

For fasteners in stand-off fixing or with distance washer, the shear tests shall be performed with the maximum possible distance.

5.2 Flexural strength ($\sigma_{u5\%}$, σ_{um})

According to EN 1469 [2] the flexural strength shall be determined from tests according to EN 12372 [6] or EN 13161 [7].

From the test results the lower expectation value $\sigma_{u5\%}$, the average value σ_{um} and the standard deviation shall be determined.

5.3 Flexural strength after weathering ($\sigma_{um,exp}$)

The flexural strength after weathering $\sigma_{um,exp}$ shall be determined as follow:

$$\sigma_{um,exp} = \min(\sigma_{um,A}, \sigma_{um,B}, \sigma_{um,C}) \quad (34)$$

with: $\sigma_{um,A}$ = average value of flexural strength determined on wet samples which have been previously immersed in water for 24 hours or until about 100% water saturation

$\sigma_{um,B}$ = average value of flexural strength after freeze-thaw-cycle tests according to EN 12371 [9]

$\sigma_{um,C}$ = average value of flexural strength after thermal and moisture cycle tests according to EN 16306 [10] (only for marble)

The samples for determination of the flexural strength without weathering (σ_{um}) and after weathering ($\sigma_{um,exp}$) shall be made from one and the same batch.

5.4 Ultimate tension load of the fastener ($N_{u5\%}$)

The ultimate resistance of the fastener to tension load shall be determined by tests. Considering the panel thickness, embedment depth and edge distance of the fastener tests shall be performed according to Table 5.1.

Table 5.1: Tests on fasteners fixed in panel sections

	nominal panel thickness	embedment depth	edge distance		dimension of test member		diameter of support	number of tests
	h	h_s	a_{rH}	a_{rL}	H	L	d_{sup}	n
	[mm]	[mm]	[mm]		[mm]		[mm]	[-]
tension load ¹⁾	$20(30)^2 \leq h$	10 to 20	≥ 100	≥ 100	≥ 200	≥ 200	≥ 135	10
			≥ 50	≥ 50				

1) test sketches see Figure 5.2

2) for sandstone, limestone and basaltlava: panel thickness $h \geq 30$ mm, if the flexural strength of the material $\sigma_{5\%} < 8$ N/mm²

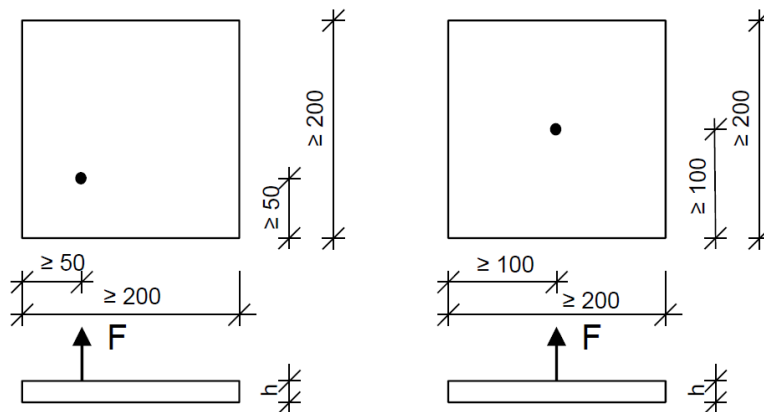

Figure 5.2: Tension tests

From the test results the lower expectation value $N_{u5\%}$, the average value N_{um} and the standard deviation shall be determined with respect to the panel thickness, the setting depth and edge distance of the fastener.

5.5 Ultimate shear load of the fastener ($V_{u5\%}$)

The ultimate resistance of the fastener to tension load shall be determined by tests. Considering the panel thickness, embedment depth and edge distance of the fastener tests shall be performed according to Table 5.2.

Table 5.2: Tests on fasteners fixed in panel sections

	nominal panel thickness	embedment depth	edge distance		dimension of test member		diameter of support	number of tests
	h	h_s	a_{rH}	a_{rL}	H	L	d_{sup}	n
	[mm]	[mm]	[mm]		[mm]		[mm]	[-]
shear load ^{1) 2)}	$20(30)^3 \leq h$	10 to 20	≥ 100	≥ 100	≥ 200	≥ 400	-	10
			≥ 50	≥ 50				

1) test sketches see Figure 5.3 to Figure 5.4

2) the fasteners are tested with the maximum possible distance (stand-off-fixing)

3) for sandstone, limestone and basaltlava: panel thickness $h \geq 30$ mm, if the flexural strength of the material $\sigma_{5\%} < 8$ N/mm²

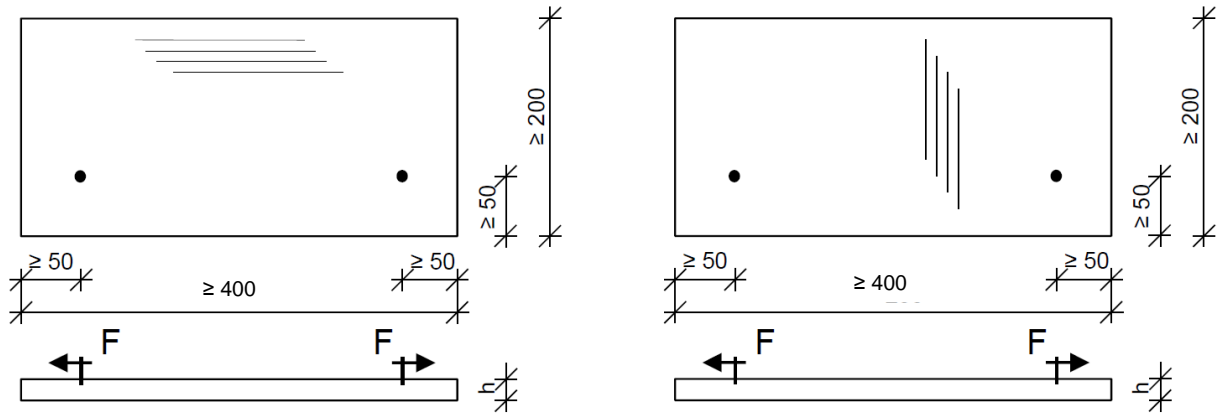

Figure 5.3: Shear test for an edge distance 50 / 50 mm

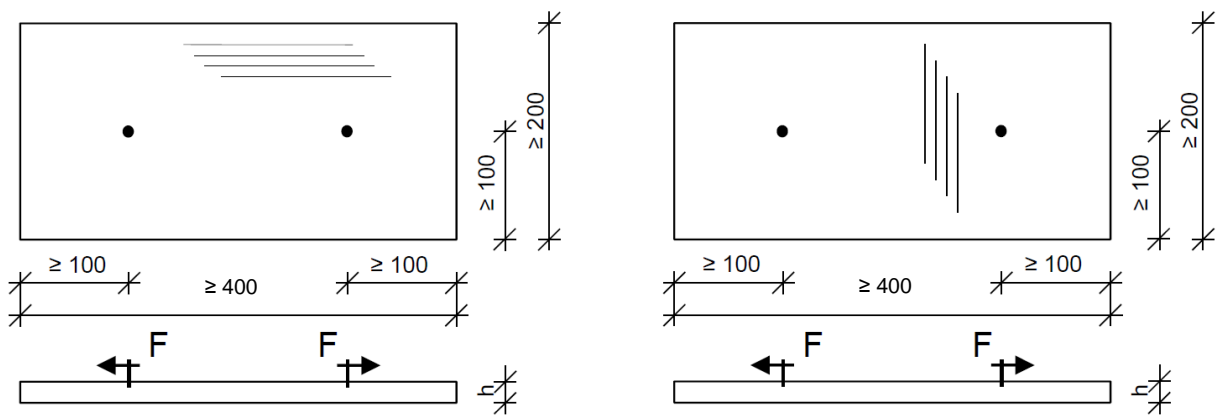

Figure 5.4: Shear test for an edge distance 100 / 100 mm

From the test results the lower expectation value $V_{u5\%}$, the average value V_{um} and the standard deviation shall be determined with respect to the panel thickness, the setting depth and edge distance of the fastener.

6 REFERENCE DOCUMENTS

As far as no edition date is given in the list of standards thereafter, the standard in its current version at the time of issuing the European Technical Assessment is of relevance.

- | | | |
|------|--------------------------------------|--|
| [1] | EAD 330030-00-0601 | Fastener of external wall claddings |
| [2] | EN 1469:2015 | Natural stone products – Slabs for cladding – Requirements |
| [3] | EN 1936:2006 | Natural stone test method – Determination of real density and apparent density, and of total and open porosity |
| [4] | EN 13755:2008 | Natural stone test methods – Determination of water absorption at atmospheric pressure |
| [5] | EN 1991-1-4:2005 + A1:2010 + AC:2010 | Eurocode 1: Actions on structures – Part 1-4: General actions – Wind actions |
| [6] | EN 12372:2006 | Natural stone test methods - Determination of flexural strength under concentrated load |
| [7] | EN 13161:2008 | Natural stone test methods - Determination of flexural strength under constant moment |
| [8] | EN 1990:2002 + A1:2005 / AC:2010 | Eurocode 0: Basis of structural design |
| [9] | EN 12371:2010 | Natural stone test methods - Determination of frost resistance |
| [10] | EN 16306:2013 | Natural stone test methods - Determination of resistance of marble to thermal and moisture cycles |
| [11] | EN 12440:2008 | Natural stone – Denomination criteria |