

## EUROPEAN ASSESSMENT DOCUMENT

EAD 340275-00-0104

January 2018

# EXTERNALLY-BONDED COMPOSITE SYSTEMS WITH INORGANIC MATRIX FOR STRENGTHENING OF CONCRETE AND MASONRY STRUCTURES

The reference title and language for this EAD is English. The applicable rules of copyright refer to the document elaborated in and published by EOTA.

This European Assessment Document (EAD) has been developed taking into account up-to-date technical and scientific knowledge at the time of issue and is published in accordance with the relevant provisions of Regulation (EU) No 305/2011 as a basis for the preparation and issuing of European Technical Assessments (ETA).

## Contents

<b>1</b>	<b>Scope of the EAD .....</b>	<b>4</b>
1.1	Description of the construction product .....	4
1.2	Information on the intended use(s) of the construction product .....	5
1.2.1	Intended use(s).....	5
1.2.2	Working life/Durability .....	5
1.3	Specific terms used in this EAD (if necessary in addition to the definitions in CPR, Art 2) .....	5
1.3.1	Notation.....	5
1.3.2	Indices.....	6
<b>2</b>	<b>Essential characteristics and relevant assessment methods and criteria.....</b>	<b>7</b>
2.1	Essential characteristics of the product .....	7
2.2	Methods and criteria for assessing the performance of the product in relation to essential characteristics of the product .....	10
2.2.1	Mechanical properties of the kit.....	11
2.2.2	Interlaminar shear strength .....	11
2.2.3	Lap tensile strength .....	12
2.2.4	Bond strength on substrates .....	12
2.2.4.1	Pull-off test.....	13
2.2.4.2	Single-lap shear test.....	13
2.2.5	Pull-out from substrates .....	14
2.2.6	Freezing and Thawing .....	14
2.2.7	Water resistance.....	15
2.2.8	Saltwater resistance.....	15
2.2.9	Alkali resistance.....	16
2.2.10	Alkali soil resistance.....	16
2.2.11	Dry heat resistance.....	17
2.2.12	Fuel resistance .....	17
2.2.13	Creep behaviour related to the adhesion on substrates .....	18
2.2.14	Tensile strength after long-term actions (creep).....	18
2.2.15	Tensile strength after low number of cycles (seismic behavior).....	19
2.2.16	Tensile strength after high number of cycles (fatigue actions).....	19
2.2.17	Conventional limit properties of composite system .....	20
2.2.18	Tensile behaviour of bent composite system ( <i>only with steel fabric</i> ).....	20
2.2.19	Reaction to fire .....	21
<b>3</b>	<b>Assessment and verification of constancy of performance .....</b>	<b>22</b>
3.1	System(s) of assessment and verification of constancy of performance to be applied .....	22
3.2	Tasks of the manufacturer .....	22
3.3	Tasks of the notified body .....	24
<b>4</b>	<b>Reference documents .....</b>	<b>25</b>
<b>Annex A</b>	<b>Summary of tests.....</b>	<b>27</b>
<b>Annex B</b>	<b>Tensile testing of composite specimens .....</b>	<b>30</b>
<b>Annex C</b>	<b>Single-Lap Shear Test .....</b>	<b>34</b>
<b>Annex D</b>	<b>Pull-out test.....</b>	<b>39</b>
<b>Annex E</b>	<b>Tensile Testing Of Dry Fabric.....</b>	<b>40</b>

# 1 SCOPE OF THE EAD

## 1.1 Description of the construction product

The “externally-bonded composite system with inorganic matrix” is a structural reinforcement system consisting of a mesh (A), with different mass per unit area, and an inorganic matrix (B) that works as bonding agent on masonry and reinforced concrete structures.

The EAD applies to Fabric Reinforced Matrix (FRM) and Steel Reinforced Grout (SRG) composite systems used to strengthen masonry and concrete structures. Such systems are also referred to as Textile Reinforced Concrete (TRC), Textile Reinforced Mortars (TRM) or Inorganic Matrix-Grid composites (IMG).

The mesh (A) is an open grid fabric of strands made of fibres, consisting of primary direction (PD) and secondary direction (SD) strands connected perpendicularly. The two directions may also be referred to as weft and warp. The mesh can be constituted by the following fibres:

- PBO (Polyparaphenylene benzobisoxazole)
- Carbon
- Alkali Resistant (AR) glass
- Aramid
- Basalt
- Steel

It can be unidirectional or bidirectional.

Meshes can be also made of a combination of alkali-resistant glass and aramid fibres, or basalt fibre, with a special alkali-resistant protective treatment made of solvent-free water-based resin, and AISI 304 stainless steel micro-threads welded together to guarantee a stable fabric with the same weight in both directions.

The steel fabric is made of Ultra High Tensile Strength galvanized Steel (UHTSS) micro wires which are twisted around each other to form cords made of five wires, three straight and two twisted around them. The twisting of the individual wires to form the cords provides an interlocking mechanism with the matrix to enhance bond. To provide protection against corrosion, the micro wires are coated with zinc in accordance with EN 10244-2<sup>1</sup> or ASTM A475-03(2014) with a minimum mass of 22g/kg (0.35 oz./lb.)

The matrix (B) is an inorganic mortar (cement- or hydraulic lime-based mortar).

Organic matrixes, like those used for FRP systems, are excluded from the scope of the EAD.

The mesh (A) is bonded to the surface of the structural element through the bonding agent (B). The reinforcement can be arranged in different morphologies, depending on the shape of the structural element to be reinforced and on the internal loads acting on the component. The bonding agent (B) is firstly applied on the surface of the structural element, then the mesh (A) is applied and pressed in it and completely covered by a second layer of mortar (B). If there are additional layers after the first, one can proceed by laying a second layer of mesh over the mortar while it is still wet, repeating the steps described above. Application of the reinforcement is typically handmade.

The product is not covered by a harmonised European standard (hEN).

Concerning product packaging, transport, storage, maintenance, replacement and repair it is the responsibility of the manufacturer to undertake the appropriate measures and to advise his clients on the transport, storage, maintenance, replacement and repair of the product as he considers necessary.

It is assumed that the product will be installed according to the manufacturer's instructions or (in absence of such instructions) according to the usual practice of the building professionals.

Relevant manufacturer's stipulations having influence on the performance of the product covered by this European Assessment Document shall be considered for the determination of the performance and detailed in the ETA.

---

<sup>1</sup> All undated references to standards or to EADs in this document are to be understood as references to the dated versions listed in Clause 4.

## 1.2 Information on the intended use(s) of the construction product

### 1.2.1 Intended use(s)

The composite system (kit) is intended to be used in highly specialized applications to strengthen masonry and reinforced concrete structures in either flexure, shear, pure axial and combined axial-bending stresses. In particular, it is used to increase the load bearing capacity, to enhance the strength, stiffness and ductility of undersized or damaged structural elements, to improve the strength and stiffness of beam-column joints and to reduce ultimate limit state deformations of structural elements. The product is to be used for strengthening of structural elements subject to static, quasi-static and dynamic loading.

Different layers of composite system can be used to satisfy the strengthening design according to the manufacturer's instructions.

### 1.2.2 Working life/Durability

The assessment methods included or referred to in this EAD have been written based on the manufacturer's request to take into account a working life of the "externally-bonded composite system with inorganic matrix" for the intended use of 50 years when installed in the works (provided that the "externally-bonded composite system with inorganic matrix" is subject to appropriate installation). These provisions are based upon the current state of the art and the available knowledge and experience.

When assessing the product the intended use as foreseen by the manufacturer shall be taken into account. The real working life may be, in normal use conditions, considerably longer without major degradation affecting the basic requirements for works<sup>2</sup>.

The indications given as to the working life of the construction product cannot be interpreted as a guarantee neither given by the product manufacturer or his representative nor by EOTA when drafting this EAD nor by the Technical Assessment Body issuing an ETA based on this EAD, but are regarded only as a means for expressing the expected economically reasonable working life of the product.

## 1.3 Specific terms used in this EAD (if necessary in addition to the definitions in CPR, Art 2)

### 1.3.1 Notation

$A_f$	Cross-sectional area of a single yarn
$A_{f,tot}$	Fabric cross-sectional area
$b$	Specimen width
$b_f$	Width of bonded composite (single lap shear test)
$d_f$	Distance between the beginning of the bonded area and the top edge of the substrate in the single lap shear test
$E_1$	Stiffness modulus in Stage A, uncracked (tensile testing of composite)
$E_3$	Stiffness modulus in Stage C, cracked (tensile testing of composite)
$E_{3,sec}$	Secant modulus of elasticity (tensile testing of composite)
$E_f$	Mean elastic modulus of fabric
$f_b$	Substrate compressive strength
$f_h$	Pull-off strength
$f_{h,ret}$	Retained pull-off strength after conditioning
$f_{h,sub}$	Substrate axial surface strength
$F_u$	Failure load
$g$	Global slip

<sup>2</sup> The real working life of a product incorporated in a specific works depends on the environmental conditions to which that works is subject, as well as on the particular conditions of the design, execution, use and maintenance of that works. Therefore, it cannot be excluded that in certain cases the real working life of the product may also be shorter than referred to above.

$k_n$	Coefficient for the evaluation of the characteristic value
$l$	Specimen length/bonded length
$L_f$	Total length of composite strip
$l_{lap}$	Lap length
$l_{yarn}$	Yarn length
$n$	Number of yarns
$n_{fatigue}$	Number of cycles causing failure for fatigue
$n_{h,creep}$	Time at which the failure occurs (number of hours)
$n_{seism}$	Number of cycles causing failure (cyclic loading)
$P_{deb}$	Bond capacity in single lap shear test
$P_{max}$	Maximum load in single lap shear test
$p_{yarn}$	Yarn weight
$\epsilon_{lim,conv}$	Conventional limit strain
$\epsilon_u$	Ultimate strain
$\epsilon_{u,f}$	Ultimate strain of fabric
$\epsilon_{u,x}$	Failure deformation at x hours ( $x = n_{h,creep}$ )
$\epsilon_x$	Deformation relative to the examination time x ( $x = 100, 500, 1000$ or $4000$ hours)
$\delta_{pull-out}$	Pull-out displacement
$\Delta\epsilon_f$	Difference in tensile strain between two selected points
$\Delta\sigma_f$	Difference in tensile stress between two selected points
$\rho$	Fibre density
$\sigma_{lap}$	Lap tensile strength
$\sigma_{lim,conv}$	Conventional limit stress
$\sigma_{pull-out}$	Pull-out strength
$\sigma_u$	Ultimate tensile stress
$\sigma_{u,f}$	Ultimate tensile stress of fabric
$\sigma_{u,f,bent}$	Tensile strength of bent fabric
$\tau$	Interlaminar shear strength

### 1.3.2 Indices

<i>alk</i>	alkali
<i>bent</i>	bent fabric
<i>deb</i>	debonding
<i>fatigue</i>	fatigue
<i>FT</i>	Freeze-Thaw
<i>fuel</i>	conditioning in fuel
<i>heat</i>	dry heat conditioning
<i>lap</i>	Lap tensile
<i>ret</i>	retained property after conditioning
<i>seism</i>	Seismic (cyclic loading)
<i>soil</i>	conditioning in soil
<i>sub</i>	substrate
<i>sw</i>	saltwater
<i>w</i>	water

## 2 ESSENTIAL CHARACTERISTICS AND RELEVANT ASSESSMENT METHODS AND CRITERIA

### 2.1 Essential characteristics of the product

Table 2.1 shows how the performance of the “Externally-bonded composite systems with inorganic matrix for strengthening of concrete and masonry structures” is assessed in relation to the essential characteristics.

**Table 2.1 Essential characteristics of the product and methods and criteria for assessing the performance of the product in relation to those essential characteristics**

No	Essential characteristic	Assessment method	Type of expression of product performance (level, class, description)
<b>Basic Works Requirement 1: Mechanical resistance and stability</b>			
1	Tensile strength	2.2.1	Level $\sigma_u$ [MPa]
2	Strain		Level $\epsilon_u$ [%]
3	Stress-strain curve		Level and description $E_1$ [GPa] $E_3$ [GPa]
4	Interlaminar shear strength	2.2.2	Level and description $\tau$ [MPa] and failure mode
5	Lap tensile strength	2.2.3	Level Lap length, $l_{lap}$ [mm] Lap tensile strength, $\sigma_{lap}$ [MPa]
6	Bond strength on substrate: pull-off test	2.2.4.1	Level $f_h$ [MPa] $f_{h,ret}$ [%] (and relative exposure conditions)
7	Bond strength on substrate: single-lap shear test	2.2.4.2	Level $P_{max}$ [N] $P_{deb}$ [N] $\sigma_{lim,conv}$ [MPa]  $P_{max,ret}$ [%] $P_{deb,ret}$ [%] (and relative exposure conditions)
8	Pull-out from substrate	2.2.5	Level Pull-out strength $\sigma_{pull-out}$ [MPa] Pull-out displacement $\delta_{pull-out}$ [mm]  Retained pull-out strength $\sigma_{pull-out,ret}$ [%] (and relative exposure conditions)

No	Essential characteristic	Assessment method	Type of expression of product performance (level, class, description)
9	Freezing and Thawing	2.2.6	<p>Level and description</p> <p>Tensile strength <math>\sigma_{u,FT}</math> [MPa]  Stiffness moduli <math>E_{1,FT}</math> and <math>E_{3,FT}</math> [GPa]  Strain <math>\varepsilon_{u,FT}</math> [%]  Interlaminar shear strength <math>\tau_{FT}</math> [MPa]</p> <p>Retained tensile strength <math>\sigma_{u,FT,ret}</math> [%]  Retained stiffness moduli <math>E_{1,FT,ret}</math> and <math>E_{3,FT,ret}</math> [%]  Retained interlaminar shear strength <math>\tau_{FT,ret}</math> [%]  (and relative exposure conditions)</p>
10	Water resistance	2.2.7	<p>Level and description</p> <p>Tensile strength <math>\sigma_{u,w}</math> [MPa]  Stiffness moduli <math>E_{1,w}</math> and <math>E_{3,w}</math> [GPa]  Strain <math>\varepsilon_{u,w}</math> [%]  Interlaminar shear strength <math>\tau_w</math> [MPa]  Lap tensile strength <math>\sigma_{lap,w}</math> [MPa]</p> <p>Retained tensile strength <math>\sigma_{u,w,ret}</math> [%]  Retained stiffness moduli <math>E_{1,w,ret}</math> and <math>E_{3,w,ret}</math> [%]  Retained interlaminar shear strength <math>\tau_{w,ret}</math> [%]  Retained lap tensile strength <math>\sigma_{lap,w,ret}</math> [%]  (and relative exposure conditions)</p>
11	Saltwater resistance	2.2.8	<p>Level and description</p> <p>Tensile strength <math>\sigma_{u,sw}</math> [MPa]  Stiffness moduli <math>E_{1,sw}</math> and <math>E_{3,sw}</math> [GPa]  Strain <math>\varepsilon_{u,sw}</math> [%]  Interlaminar shear strength <math>\tau_{sw}</math> [MPa]  Lap tensile strength <math>\sigma_{lap,sw}</math> [MPa]</p> <p>Retained tensile strength <math>\sigma_{u,sw,ret}</math> [%]  Retained stiffness moduli <math>E_{1,sw,ret}</math> and <math>E_{3,sw,ret}</math> [%]  Retained interlaminar shear strength <math>\tau_{sw,ret}</math> [%]  Retained lap tensile strength <math>\sigma_{lap,sw,ret}</math> [%]  (and relative exposure conditions)</p>



No	Essential characteristic	Assessment method	Type of expression of product performance (level, class, description)
12	Alkali resistance	2.2.9	<p>Level and description</p> <p>Tensile strength <math>\sigma_{u,alk}</math> [MPa]  Stiffness moduli <math>E_{1,alk}</math> and <math>E_{3,alk}</math> [GPa]  Strain <math>\varepsilon_{u,alk}</math> [%]  Interlaminar shear strength <math>\tau_{alk}</math> [MPa]  Lap tensile strength <math>\sigma_{lap,alk}</math> [MPa]</p> <p>Retained tensile strength <math>\sigma_{u,alk,ret}</math> [%]  Retained stiffness moduli <math>E_{1,alk,ret}</math> and <math>E_{3,alk,ret}</math> [%]  Retained interlaminar shear strength <math>\tau_{alk,ret}</math> [%]  Retained lap tensile strength <math>\sigma_{lap,alk,ret}</math> [%]  (and relative exposure conditions)</p>
13	Alkali soil resistance	2.2.10	<p>Level and description</p> <p>Tensile strength <math>\sigma_{u,soil}</math> [MPa]  Stiffness moduli <math>E_{1,soil}</math> and <math>E_{3,soil}</math> [GPa]  Strain <math>\varepsilon_{u,soil}</math> [%]</p> <p>Retained tensile strength <math>\sigma_{u,soil,ret}</math> [%]  Retained stiffness moduli <math>E_{1,soil,ret}</math> and <math>E_{3,soil,ret}</math> [%]  (and relative exposure conditions)</p>
14	Dry heat resistance	2.2.11	<p>Level and description</p> <p>Tensile strength <math>\sigma_{u,heat}</math> [MPa]  Stiffness moduli <math>E_{1,heat}</math> and <math>E_{3,heat}</math> [GPa]  Strain <math>\varepsilon_{u,heat}</math> [%]</p> <p>Retained tensile strength <math>\sigma_{u,heat,ret}</math> [%]  Retained stiffness moduli <math>E_{1,heat,ret}</math> and <math>E_{3,heat,ret}</math> [%]  (and relative exposure conditions)</p>
15	Fuel resistance	2.2.12	<p>Level and description</p> <p>Tensile strength <math>\sigma_{u,fuel}</math> [MPa]  Stiffness moduli <math>E_{1,fuel}</math> and <math>E_{3,fuel}</math> [GPa]  Strain <math>\varepsilon_{u,fuel}</math> [%]</p> <p>Retained tensile strength <math>\sigma_{u,fuel,ret}</math> [%]  Retained stiffness moduli <math>E_{1,fuel,ret}</math> and <math>E_{3,fuel,ret}</math> [%]  (and relative exposure conditions)</p>
16	Creep behaviour related to the adhesion on substrate	2.2.13	<p>Level and description</p> <p>Displacement vs time (tabular)  Maximum load <math>P_{max,creep}</math> [N] after creep  Bond capacity <math>P_{deb,creep}</math> [N] after creep</p>

No	Essential characteristic	Assessment method	Type of expression of product performance (level, class, description)
17	Tensile strength after long term actions (creep)	2.2.14	Level and description Load causing failure Deformation $\epsilon_{u,x}$ [%] Time at which the failure occurs $n_{h,creep}$ or Deformation $\epsilon_x$ Retained mechanical properties ( $\sigma_{u,creep,ret}$ [%], $E_{1,creep,ret}$ and $E_{3,creep,ret}$ [%])
18	Tensile strength after low number of cycles (seismic behaviour)	2.2.15	Level and description Number of cycles causing failure $n_{seism}$ or Tensile strength $\sigma_{u,seism}$ [MPa] Stiffness moduli $E_{1,seism}$ and $E_{3,seism}$ [GPa] Strain $\epsilon_{u,seism}$ [%]
19	Tensile strength after high number of cycles (fatigue actions)	2.2.16	Level and description Number of cycles causing failure $n_{fatigue}$ or Tensile strength $\sigma_{u,fatigue}$ [MPa] Stiffness moduli $E_{1,fatigue}$ and $E_{3,fatigue}$ [GPa] Strain $\epsilon_{u,fatigue}$ [%]
20	Conventional limit properties of composite system	2.2.17	Level and description Ultimate stress $\sigma_{u,f}$ [MPa] Ultimate strain $\epsilon_{u,f}$ [%] Mean elastic modulus $E_f$ [GPa] Conventional limit strain $\epsilon_{lim,conv}$ [%]
21	Tensile behaviour of bent composite system (only with steel fabric)	2.2.18	Level Tensile strengths $\sigma_{u,f,straight}$ and $\sigma_{u,f,bent}$ [MPa] (ambient) Tensile strengths $\sigma_{u,f,straight,sw}$ and $\sigma_{u,f,bent,sw}$ [MPa] (saltwater conditioning)
Basic Works Requirement 2: Safety in case of fire			
22	Reaction to fire	2.2.19	Class

## 2.2 Methods and criteria for assessing the performance of the product in relation to essential characteristics of the product

This chapter is intended to provide instructions for TABs. Therefore, the use of wordings such as “shall be stated in the ETA” or “it has to be given in the ETA” shall be understood only as such instructions for TABs on how results of assessments shall be presented in the ETA. Such wordings do not impose any obligations for the manufacturer and the TAB shall not carry out the assessment of the performance in relation to a given essential characteristic when the manufacturer does not wish to declare this performance in the Declaration of Performance.

Where not explicitly expressed, the *mean value* is intended here as the arithmetic mean, i.e. the sum of the numerical values of a data collection divided by the number of data in the collection.

## 2.2.1 Mechanical properties of the kit

### Purpose of the test

Tensile tests are performed to evaluate the tensile strength, the stiffness moduli and the ultimate strain of the composite system, together with the stress-strain curve.

### Test method

The mechanical properties of the specimens shall be determined according to the procedure summarized in Annex B.

Tests shall be conducted parallel to the primary direction of the reinforcement fabric. Tests in the secondary direction may be conducted as a choice of the manufacturer.

Tests shall be conducted considering the number of layers proposed by the manufacturer in the instructions. In case of more layers, test the minimum and the maximum number of layers. If values of mechanical properties are significantly different, test at least one intermediate value of layers. Interpolation for intermediate sizes may be used to determine the mechanical properties. Other tests may be necessary to confirm the assumed interpolation formula.

A minimum number of twenty samples for each number of layers to be subjected to uniaxial tensile test have to be prepared for each composite system configuration (i.e. weight per unit area), laid up according to the procedure indicated in Annex B and the manufacturer's instructions.

Tests shall be performed at a temperature of  $23\pm 2^\circ\text{C}$  and  $50\pm 5\%$  relative humidity (RH), and if specified by the manufacturer, at the maximum service temperature.

### Assessment

The mechanical properties to be determined and reported in the ETA are (see Annex B and Figure B2 for the meaning of symbols):

- a) Tensile elastic modulus of stage A,  $E_1$  (average value) [GPa].
- b) Failure stress  $\sigma_u$  (characteristic value) and strain  $\varepsilon_u$  [%].
- c) Tensile stiffness modulus of phase C,  $E_3$  (average value) [GPa].

The relative testing conditions in terms of T and RH shall be also reported in the ETA. When assessing the properties with conditions different by the standard laboratory ones, the properties shall include the subscript corresponding to the testing temperature, e.g.

$$\sigma_{u,X}, \varepsilon_{u,X}, E_{1,X} \text{ and } E_{3,X}, \quad \text{with } X=\text{testing temperature in } ^\circ\text{C}$$

The characteristic value will be determined by using the appropriate value of  $k_n$  for unknown  $V_x$  reported in EN 1990, Annex D, Table D1.

## 2.2.2 Interlaminar shear strength

### Purpose of the test

This test method allows to determine the apparent interlaminar shear strength by the short-beam method.

### Test method

Composite interlaminar shear strength tests on composite panels shall follow the general procedures of EN ISO 14130. In any case, the following specimen dimensions have to be respected:

Specimen length,  $l = 10 \times$  thickness

Specimen width,  $b = 5 \times$  thickness

The thickness shall be obtained by overlapping at least two layers of composite material.

A minimum number of twenty specimens are required to be tested under standard condition of temperature and relative humidity ( $23\pm 2^{\circ}\text{C}$ ,  $50\pm 5\%$  RH). A summary of the number of specimens to be tested is reported in Annex A.

### Assessment

The average (arithmetic mean) and characteristic value of the interlaminar shear strength  $\tau$  [MPa] and the failure mode have to be determined.

The characteristic value will be determined by using the appropriate value of  $k_n$  for unknown  $V_x$  reported in EN 1990, Annex D, Table D1.

If failure modes different from the interlaminar shear occur, the statement “No interlaminar shear failure evidenced” shall be reported in the ETA.

## **2.2.3 Lap tensile strength**

### Purpose of the test

When applying composite materials for strengthening of structural masonry or concrete members, splices and laps can be necessary for the grid reinforcement. To determine the relative tensile strength at the grid overlap area, lap tensile strength testing is required.

### Test method

This test shall be performed on specimens with a joint configuration that closely simulates the actual joint in field application. The general test procedures as described in Annex B shall be used on tension tests of composite panels. The specimens shall consist of only one layer of lapped composite material. The fabric in the panel shall be two pieces with an overlap length in the middle. The tested lap length shall be the minimum lap length recommended by the manufacturer; however, the lap length should not be shorter than the tab length defined in Annex B. Each piece of fabric shall have the same dimensions as described in the tensile strength testing (Section 2.2.1), such that the overlap length is positioned at mid-length of the tests specimen.

Ten specimens shall be tested in standard laboratory conditions ( $23\pm 2^{\circ}\text{C}$ ,  $50\pm 5\%$  RH). A summary of the number of specimens to be tested is reported in Annex A.

### Assessment

The used overlap length  $l_{lap}$  [mm] shall be reported in the ETA.

The average (arithmetic mean) and characteristic value of the lap tensile strength  $\sigma_{lap}=F/A_{f,tot}$  [MPa] have to be determined, where  $A_{f,tot}$  represents the fabric cross sectional area evaluated as the number of yarns  $n$  multiplied by the single yarn cross sectional area  $A_f$  (see Annex E). The characteristic value will be determined by using the appropriate value of  $k_n$  for unknown  $V_x$  reported in EN 1990, Annex D, Table D1.

## **2.2.4 Bond strength on substrates**

### Definition of reference substrates

- *Concrete*

Concrete type MC (0,40) will be prepared with the sandblasted surface in accordance with EN 1766.

- *Masonry*

Masonry shall be compliant with EN 771-1 (clay) and EN 771-6 (natural stones) and must be chosen with as homogeneous as possible mechanical and physical-chemical characteristics, to reduce the dispersion of the results. In particular, clay bricks shall have a compressive strength comprised in the range 15-25 MPa. The average effective resistance must be evaluated through at least six compression tests on cubic/cylindrical samples of brick, of approximately 50 mm size/diameter, made of the brick thickness. The general procedure of EN 772-1 shall be followed.

For the realization of masonry specimens a mortar with class not exceeding M5 shall be used (EN 998-2).

Natural stone bricks (tuff) shall have a compressive strength comprised in the range 4-12 MPa. The average effective resistance must be evaluated through at least six compression tests on cubic samples (EN 772-1), of approximately 150 mm size.

Natural stones (limestone) irregular in shape, not squared, whose larger size is less than 150 mm, shall have a compressive strength comprised in the range 50-150 MPa. The compressive strength of the stones must be evaluated through at least six compression tests (EN 1926). For the preparation of masonry specimens a mortar with class not higher than M2.5 (EN 998-2) shall be used.

#### **2.2.4.1 Pull-off test**

##### Purpose of the test

The test allows to determine the adhesive strength of bonded composite system on different substrates. It determines the bond strength to the substrate or the tensile strength of either the overlay or substrate, whichever is weaker.

##### Test method

For tensile bond testing, thirty-five composite specimens shall be prepared for each substrate. One layer of composite material shall be applied onto the substrate according to the manufacturer's instructions. Thirty specimens shall then be exposed to water, saltwater and alkali conditions for 1,000 and 3,000 hours according to the procedures of 2.2.7, 2.2.8 and 2.2.9. Five specimens shall be kept in standard laboratory conditions ( $23\pm 2^\circ\text{C}$ ,  $50\pm 5\%$  RH) as control specimens. A summary of the minimum number of specimens to be tested is reported in Annex A.

The test shall follow the general procedures of EN 1542 with the following deviations to take into account the different substrates:

- Concrete: prisms with 300 mm x 300 mm x 100 mm sizes (according to EN 1542) and concrete type MC (0,40) (according to EN 1766);
- Masonry: test shall be conducted on solid bricks. Dollies shall be bonded on the larger surface of the brick or natural stone leaving a distance from the edges equal to the size of the dollies.

When a circular cut is not feasible, it shall be allowed to cut the substrate in a hexagonal geometry to circumscribe the disk used for testing.

##### Assessment

The failure mode has to be recorded for each individual test result according to the indications of EN 1542.

The average (arithmetic mean) pull-off strength  $f_h$  [MPa] shall be reported in the ETA, together with the compressive strength of the substrate  $f_b$  [MPa] and the axial surface strength of the substrate  $f_{h,sub}$  [MPa] according to EN 1542.

The percentage of bond capacity  $f_{h,ret}$  [%] retained by exposed specimens with respect to control specimens and the exposure conditions shall also be reported in the ETA.

#### **2.2.4.2 Single-lap shear test**

##### Purpose of the test

The test allows to determine the shear bond strength of composite systems adhesively applied to a flat concrete or masonry substrate.

##### Test method

A minimum of thirty-five composite specimens shall be prepared. One layer of composite shall be applied onto the substrate in accordance with the manufacturer's instructions. Thirty specimens shall then be exposed to water, saltwater and alkali conditions for 1,000 and 3,000 hours according to the procedures of

2.2.7, 2.2.8 and 2.2.9. Five specimens shall be kept in standard laboratory conditions ( $23\pm 2^\circ\text{C}$ ,  $50\pm 5\%$  RH) as control specimens. The test shall follow the general procedure reported in Annex C.

A summary of the number of specimens to be tested is reported in Annex A.

### Assessment

The average (arithmetic mean) and characteristic value of the maximum load  $P_{max}$  [N], the bond capacity  $P_{deb}$  [N] and the conventional limit stress  $\sigma_{lim,conv}$  [MPa] shall be reported in the ETA, together with the compressive strength of the substrate  $f_b$  [MPa] and the axial surface strength of the substrate  $f_{n,sub}$  [MPa] according to EN 1542. The characteristic value will be determined by using the appropriate value of  $k_n$  for unknown  $V_x$  reported in EN 1990, Annex D, Table D1.

The percentage of bond capacity ( $P_{max,ret}$  [%] and  $P_{deb,ret}$  [%]) retained by exposed specimens with respect to control specimens and the exposure conditions shall also be reported in the ETA.

## **2.2.5 Pull-out from substrates**

### Purpose of the test

The possibility to anchor the composite sheet inside the structural element to be strengthened is foreseen to improve the anchorage strength of the reinforcement. The test is therefore performed to determine the pull-out strength of composite anchors from different substrates.

### Test method

Thirty-five composite specimens shall be prepared according to the indications given in Annex C. The composite material shall be anchored in the substrate in accordance with the manufacturer's instructions. Thirty specimens shall then be exposed to water, saltwater and alkali conditions for 1,000 and 3,000 hours according to the procedures of 2.2.7, 2.2.8 and 2.2.9. Five specimens shall be kept in standard laboratory conditions ( $23\pm 2^\circ\text{C}$ ,  $50\pm 5\%$  RH) as control specimens. Test shall be performed according to EN 1881, with the deviations indicated in Annex D.

### Assessment

A description of the type of failure or combination of failure types shall be given.

The average pull-out strength  $\sigma_{pull-out} = F_{max}/A_{f,tot}$  [MPa] and the value of displacement in correspondence of the peak load  $\delta_{pull-out}$  [mm] shall be reported in the ETA, together with the compressive strength of the substrate  $f_b$  [MPa] and the axial surface strength of the substrate  $f_{n,sub}$  [MPa] according to EN 1542.

The percentage of pull-out strength  $\sigma_{pull-out,ret}$  [%] retained by exposed specimens with respect to control specimens and the exposure conditions shall also be reported in the ETA.

## **2.2.6 Freezing and Thawing**

### Purpose of the test

This test is performed to evaluate the influence of freeze-thaw cycles on the behaviour of the composite system.

### Test method

Freezing and thawing conditioning shall be conducted on both tension composite panel specimens (Section 2.2.1-minimum number of fabric layers) and interlaminar shear specimens (Section 2.2.2). The size of specimens shall be the same as that required for tensile and interlaminar shear testing (described in Section 2.2.1 and 2.2.2). The samples shall be conditioned for one week in a humidity chamber [ $>95\%$  relative humidity,  $38\pm 2^\circ\text{C}$ ]. They shall then be subjected to twenty freeze-thaw cycles. Each cycle consists of a minimum of four hours at  $-18\pm 2^\circ\text{C}$ , followed by 12 hours in a humidity chamber [ $>95\%$  relative humidity,  $38\pm 2^\circ\text{C}$ ]. The conditioned specimens are then tested in direct tension according to 2.2.1. and for interlaminar shear strength according to test described in 2.2.2. A summary of the minimum number of specimens to be tested is reported in Annex A.

### Assessment

Conditioned specimens are visually examined prior to testing using 5x magnification to describe surface changes, such as erosion, cracking, crazing, checking, and chalking.

The average (arithmetic mean) and characteristic value of the tensile strength  $\sigma_{u,FT}$  [MPa], stiffness moduli  $E_{1,FT}$  and  $E_{3,FT}$  [GPa], strain  $\epsilon_{u,FT}$  [%] and interlaminar shear strength  $\tau_{FT}$  [MPa] have to be determined. The characteristic value will be determined by using the appropriate value of  $k_n$  for unknown  $V_x$  reported in EN 1990, Annex D, Table D1.

The percentage of mechanical properties ( $\sigma_{u,FT,ret}$  [%],  $E_{1,FT,ret}$  and  $E_{3,FT,ret}$  [%]) and interlaminar shear strength  $\tau_{FT,ret}$  [%] retained by exposed specimens with respect to the value recorded for unconditioned specimens (Section 2.2.1 and 2.2.2) and the exposure conditions shall also be reported in the ETA.

### **2.2.7 Water resistance**

#### Purpose of the test

This test is performed to evaluate the influence of water on the behaviour of the composite system.

#### Test method

Conditioning shall be conducted on both tension composite panel specimens (Section 2.2.1-minimum number of fabric layers), interlaminar shear specimens (Section 2.2.2) and lap tensile specimens (Section 2.2.3). Conditioning is done according to ASTM D 2247-11 and ASTM E104-02 for 1,000 and 3,000 hours at a temperature of  $38\pm 2^\circ\text{C}$  and relative humidity >95%. Conditioned specimens are then tested in direct tension according to 2.2.1, for interlaminar shear strength according to the procedure described in 2.2.2 and for lap tensile strength according to 2.2.3. A summary of the minimum number of specimens to be tested is reported in Annex A.

#### Assessment

Conditioned specimens are visually examined prior to testing using 5x magnification to describe surface changes, such as erosion, cracking, crazing, checking, and chalking.

The average (arithmetic mean) and characteristic value of the tensile strength  $\sigma_{u,w}$  [MPa], stiffness moduli  $E_{1,w}$  and  $E_{3,w}$  [GPa], strain  $\epsilon_{u,w}$  [%], interlaminar shear strength  $\tau_w$  [MPa] and lap tensile strength  $\sigma_{lap,w}$  [MPa] have to be determined. The characteristic value will be determined by using the appropriate value of  $k_n$  for unknown  $V_x$  reported in EN 1990, Annex D, Table D1.

The percentage of average mechanical properties ( $\sigma_{u,w,ret}$  [%],  $E_{1,w,ret}$  and  $E_{3,w,ret}$  [%]), interlaminar shear strength  $\tau_{w,ret}$  [%] and lap tensile strength  $\sigma_{lap,w,ret}$  [%] retained by exposed specimens with respect to the value recorded for unconditioned specimens (Section 2.2.1, 2.2.2 and 2.2.3) and the exposure conditions shall also be reported in the ETA.

### **2.2.8 Saltwater resistance**

#### Purpose of the test

This test is performed to evaluate the influence of saltwater on the efficiency of the composite system.

#### Test method

Conditioning shall be conducted on both tension composite panel specimens (Section 2.2.1-minimum number of fabric layers), interlaminar shear specimens (Section 2.2.2) and lap tensile specimens (Section 2.2.3). Conditioning is done by immersing specimens in saltwater according to ASTM D1141-98 and ASTM C581-03 for 1,000 and 3,000 hours at a temperature of  $23\pm 2^\circ\text{C}$ . Conditioned specimens are then tested in direct tension according to 2.2.1, for interlaminar shear strength according to the procedure described in 2.2.2 and for lap tensile strength according to 2.2.3. A summary of the number of specimens to be tested is reported in Annex A.

### Assessment

Conditioned specimens are visually examined prior to testing using 5x magnification to describe surface changes, such as erosion, cracking, crazing, checking, and chalking.

The average (arithmetic mean) and characteristic value of the tensile strength  $\sigma_{u,sw}$  [MPa], stiffness moduli  $E_{1,sw}$  and  $E_{3,sw}$  [GPa], strain  $\epsilon_{u,sw}$  [%], interlaminar shear strength  $\tau_{sw}$  [MPa] and lap tensile strength  $\sigma_{lap,sw}$  [MPa] have to be determined. The characteristic value will be determined by using the appropriate value of  $k_n$  for unknown  $V_x$  reported in EN 1990, Annex D, Table D1.

The percentage of average mechanical properties ( $\sigma_{u,sw,ret}$  [%],  $E_{1,sw,ret}$  and  $E_{3,sw,ret}$  [%]), interlaminar shear strength  $\tau_{sw,ret}$  [%] and lap tensile strength  $\sigma_{lap,sw,ret}$  [%] retained by exposed specimens with respect to the value recorded for unconditioned specimens (Section 2.2.1, 2.2.2 and 2.2.3) and the exposure conditions shall also be reported in the ETA.

### **2.2.9 Alkali resistance**

#### Purpose of the test

This test is performed to evaluate the influence of alkali attack on the efficiency of the composite system.

#### Test method

Conditioning shall be conducted on both tension composite panel specimens (Section 2.2.1-minimum number of fabric layers), interlaminar shear specimens (Section 2.2.2) and lap tensile specimens (Section 2.2.3). Conditioning is done by immersing specimens in a liquid with  $pH \geq 9.5$  for 1,000 and 3,000 hours at a temperature of  $23 \pm 2^\circ C$ . Conditioned specimens are then tested in direct tension according to 2.2.1, for interlaminar shear strength according to the procedure described in 2.2.2 and for lap tensile strength according to 2.2.3. A summary of the number of specimens to be tested is reported in Annex A.

#### Assessment

Conditioned specimens are visually examined prior to testing using 5x magnification to describe surface changes, such as erosion, cracking, crazing, checking, and chalking.

The average (arithmetic mean) and characteristic value of the tensile strength  $\sigma_{u,alk}$  [MPa], stiffness moduli  $E_{1,alk}$  and  $E_{3,alk}$  [GPa], strain  $\epsilon_{u,alk}$  [%], interlaminar shear strength  $\tau_{alk}$  [MPa] and lap tensile strength  $\sigma_{lap,alk}$  [MPa] have to be determined. The characteristic value will be determined by using the appropriate value of  $k_n$  for unknown  $V_x$  reported in EN 1990, Annex D, Table D1.

The percentage of average mechanical properties ( $\sigma_{u,alk,ret}$  [%],  $E_{1,alk,ret}$  and  $E_{3,alk,ret}$  [%]), interlaminar shear strength  $\tau_{alk,ret}$  [%] and lap tensile strength  $\sigma_{lap,alk,ret}$  [%] retained by exposed specimens with respect to the values recorded for unconditioned specimens (Section 2.2.1, 2.2.2 and 2.2.3) and the exposure conditions shall also be reported in the ETA.

### **2.2.10 Alkali soil resistance**

#### Purpose of the test

This test is performed to evaluate the influence of alkali soil attack on the performance of the composite system, due to degradation induced by composite burials in soils having very low or very high pH.

#### Test method

The alkali soil resistance testing shall be performed on five tension composite panel specimens (Section 2.2.1-minimum number of fabric layers) conditioned for 1,000 hours.

Specimens shall be buried in soil vertically to a depth of about 125 mm, measured to the top of the specimen. The containers of soil and buried composite specimens shall be stored in a room with the temperature maintained between  $32^\circ C$  to  $38^\circ C$ . The soil shall be rich in cellulose-destroying microorganisms, have a pH of 6.5-7.5, and have oven-dry moisture content between 25 and 30 percent throughout the test period. The microbiological activity of the soil shall be checked frequently by tensile



testing cotton duck that has been buried in the soil, with the tensile strength losses of the cotton duck being a minimum of 70 and 90 percent after one- and two-week exposures, respectively.

At the end of 1000 hours of exposure, conditioned specimens are then tested for tensile strength, tensile moduli, and strain in accordance with Section 2.2.1.

A summary of the minimum number of specimens to be tested is reported in Annex A.

#### Assessment

Conditioned specimens are visually examined prior to testing using 5x magnification to describe surface changes, such as erosion, cracking, crazing, checking, and chalking.

The average (arithmetic mean) and characteristic value of the tensile strength  $\sigma_{u,soil}$  [MPa], stiffness moduli  $E_{1,soil}$  and  $E_{3,soil}$  [GPa] and strain  $\epsilon_{u,soil}$  [%] have to be determined. The characteristic value will be determined by using the appropriate value of  $k_n$  for unknown  $V_x$  reported in EN 1990, Annex D, Table D1.

The percentage of average mechanical properties ( $\sigma_{u,soil,ret}$  [%],  $E_{1,soil,ret}$  and  $E_{3,soil,ret}$  [%]) retained by exposed specimens with respect to the values recorded for unconditioned specimens (Section 2.2.1) and the exposure conditions shall also be reported in the ETA.

### **2.2.11 Dry heat resistance**

#### Purpose of the test

This test is performed to evaluate the influence of dry heat on the efficiency of the composite system.

#### Test method

Conditioning shall be conducted on tension composite panel specimens (Section 2.2.1-minimum number of fabric layers) according to ASTM D3045 for 1,000 and 3,000 hours. Conditioned specimens are then tested for tensile strength, tensile moduli, and strain according to 2.2.1. A summary of the minimum number of specimens to be tested is reported in Annex A.

#### Assessment

Conditioned specimens are visually examined prior to testing using 5x magnification to describe surface changes, such as erosion, cracking, crazing, checking, and chalking.

The average (arithmetic mean) and characteristic value of the tensile strength  $\sigma_{u,heat}$  [MPa], stiffness moduli  $E_{1,heat}$  and  $E_{3,heat}$  [GPa] and strain  $\epsilon_{u,heat}$  [%] have to be determined. The characteristic value will be determined by using the appropriate value of  $k_n$  for unknown  $V_x$  reported in EN 1990, Annex D, Table D1.

The percentage of average mechanical properties ( $\sigma_{u,heat,ret}$  [%],  $E_{1,heat,ret}$  and  $E_{3,heat,ret}$  [%]) retained by exposed specimens with respect to the values recorded for unconditioned specimens (Section 2.2.1) and the exposure conditions shall also be reported in the ETA.

### **2.2.12 Fuel resistance**

#### Purpose of the test

This test is performed to evaluate the influence of fuel conditioning on the efficiency of the composite system.

#### Test method

Conditioning shall be conducted on tension composite panel specimens (Section 2.2.1-minimum number of fabric layers). Specimens shall be prepared and exposed to diesel fuel reagent for a minimum of four hours. After conditioning, the specimens shall be tested for tensile strength, tensile moduli, and strain according to 2.2.1.

### Assessment

Conditioned specimens are visually examined prior to testing using 5x magnification to describe surface changes, such as erosion, cracking, crazing, checking, and chalking.

The average (arithmetic mean) and characteristic value of the tensile strength  $\sigma_{u,\text{fuel}}$  [MPa], stiffness moduli  $E_{1,\text{fuel}}$  and  $E_{3,\text{fuel}}$  [GPa] and strain  $\epsilon_{u,\text{fuel}}$  [%] have to be determined.

The characteristic value will be determined by using the appropriate value of  $k_n$  for unknown  $V_x$  reported in EN 1990, Annex D, Table D1.

The percentage of average mechanical properties ( $\sigma_{u,\text{fuel,ret}}$  [%],  $E_{1,\text{fuel,ret}}$  and  $E_{3,\text{fuel,ret}}$  [%]) retained by exposed specimens with respect to the values recorded for unconditioned specimens (Section 2.2.1) and the exposure conditions shall also be reported in the ETA.

### **2.2.13 Creep behaviour related to the adhesion on substrates**

#### Purpose of the test

This test is performed to determine the tensile creep under standard conditions of temperature or under the maximum service temperature recommended by the manufacturer.

#### Test method

Five specimens shall be prepared for each substrate according to the procedure of Section 2.2.4.2. The composite material bonded to the substrate is subjected to a continuous tensile load equal to the 30% of the corresponding averaged maximum load of Section 2.2.4.2 for half a year. During the duration of the test, the pieces are stored at  $23\pm 2^\circ\text{C}$  and  $80\pm 5\%$  RH, or such other conditions as specified by the manufacturer. After long-term loading the bond strength shall be measured for each specimens at standard environmental conditions ( $23\pm 2^\circ\text{C}$ ,  $50\pm 5\%$  RH).

#### Assessment

The displacement of each composite specimen relative to the substrate is measured and recorded:

- before applying the tensile load;
- immediately after applying the tensile load;
- start of the creep curve;
- after one day, two days and every seven days until the test is completed at six months (reference value).

The average (arithmetic mean) and characteristic value of the maximum load  $P_{\text{max,creep}}$  [N] and the bond capacity  $P_{\text{deb,creep}}$  [N] shall be reported in the ETA, together with the test conditions. The characteristic value will be determined by using the appropriate value of  $k_n$  for unknown  $V_x$  reported in EN 1990, Annex D, Table D1.

### **2.2.14 Tensile strength after long-term actions (creep)**

#### Purpose of the test

This test is performed to determine the composite system behaviour under long-term actions.

#### Test method

Minimum eight specimens shall be prepared according to the procedure of Section 2.2.1, considering the minimum number of fabric layers. The load level is determined on the basis of the 5% fractile values of the failure loads determined in the tensile tests in accordance with Section 2.2.1 ( $F_{u;5\%}$ ). The test shall be carried out by applying a constant load level of  $0.70 \times F_{u;5\%}$ , or such other value as specified by the manufacturer. The load is maintained for 100, 500, 1000 and 4000 hours (2 samples per each examination time).

The tests shall be carried out at temperature of  $23\pm 2^\circ\text{C}$  and  $50\pm 5\%$  RH.

In case no failure of tensile specimens is reached during the permanent load, the remaining resistance of the test specimens is determined according to Section 2.2.1 .

### Assessment

The deformation resulting from the permanent applied load shall be measured and represented as a function of time.

If failure occurs during the permanent load, the load, the time  $n_{h,creep}$  and the deformation  $\epsilon_{u,x}$  at which the failure occurs shall be reported in the ETA.

If no failure occurs during the permanent load, the deformation  $\epsilon_x$  reached at the end of the examination period shall be recorded. The percentage of average mechanical properties ( $\sigma_{u,creep,ret}$  [%],  $E_{1,creep,ret}$  and  $E_{3,creep,ret}$  [%]), retained by specimens with respect to the average short-time tensile strength determined in Section 2.2.1 shall be reported in the ETA for each examination period.

## **2.2.15 Tensile strength after low number of cycles (seismic behavior)**

### Purpose of the test

This test is performed to determine the system behaviour under cyclic loading (seismic behaviour).

### Test method

Five specimens shall be prepared according to the procedure of Section 2.2.1, with a minimum number of fabric layers.

Fifteen cycles at 1 Hz shall be applied on the specimens. The cyclic loads consist of a lower stress level equal to 5% of the respective characteristic short time tensile strength (Section 2.2.1) and an upper stress level equal to 90% of the respective characteristic short time tensile strength. If no failure occurs during the cycles, the specimens shall be tested in direct tension according to 2.2.1. Test shall be performed in standard laboratory conditions ( $23\pm 2^\circ\text{C}$ ,  $50\pm 5\%$  RH).

### Assessment

The minimum number of cycles  $n_{seism}$  causing failure shall be reported in the ETA or, if no failure occurs during the cycles, the arithmetic mean and characteristic value of the tensile strength  $\sigma_{u,seism}$  [MPa], stiffness moduli  $E_{1,seism}$  and  $E_{3,seism}$  [GPa] and strain  $\epsilon_{u,seism}$  [%] have to be determined and reported in the ETA. The characteristic value will be determined by using the appropriate value of  $k_n$  for unknown  $V_x$  reported in EN 1990, Annex D, Table D1.

## **2.2.16 Tensile strength after high number of cycles (fatigue actions)**

### Purpose of the test

This test is performed to determine the system behaviour under fatigue loading.

### Test method

Five specimens shall be prepared according to the procedure of Section 2.2.1, with a minimum number of fabric layers. Dynamic tests with  $2 \times 10^6$  cycles shall be carried out under a swing width of 10% ( $R = 0.1$ ) and an upper load correspondent to 60% of the characteristic conventional limit stress  $\sigma_{lim,conv}$  derived in the single-lap shear test (Section 2.2.4.2) for the substrate with the highest value. The testing frequency shall be chosen to be between 1 and 3 Hz. Cyclic loads shall be applied on the specimens until fatigue failure or the limit number of cycles is reached. Test specimens reaching the limit number of cycles without failure are to be tested in direct tension according to 2.2.1. Test shall be performed in standard laboratory conditions ( $23\pm 2^\circ\text{C}$ ,  $50\pm 5\%$  RH).

### Assessment

The minimum number of cycles  $n_{fatigue}$  causing failure shall be reported in the ETA or, if no failure occurs during the cycles, the arithmetic mean and characteristic value of the tensile strength  $\sigma_{u,fatigue}$  [MPa], stiffness moduli  $E_{1,fatigue}$  and  $E_{3,fatigue}$  [GPa] and strain  $\epsilon_{u,fatigue}$  [%] have to be determined and reported in the

ETA. The characteristic value will be determined by using the appropriate value of  $k_n$  for unknown  $V_x$  reported in EN 1990, Annex D, Table D1.

**2.2.17 Conventional limit properties of composite system**

Purpose of the test

A tensile test on dry fabric samples is carried out to define the conventional limit properties of the composite system.

Test method

Tensile tests shall be performed on at least 5 specimens according to the procedure indicated in Annex E at standard laboratory conditions ( $23\pm 2^\circ\text{C}$ ,  $50\pm 5\%$  RH). Test specimens are cut from the fabric roll supplied by the manufacturer in the warp direction.

Assessment

The stress strain curve shall be determined. The characteristic value of the ultimate stress  $\sigma_{u,f}$  [MPa], the ultimate strain  $\epsilon_{u,f}$  [%], the average elastic modulus  $E_f$  [GPa], and the conventional limit strain  $\epsilon_{lim,conv}$  [%] (Annex E) shall be determined and reported in the ETA. The characteristic value will be determined by using the appropriate value of  $k_n$  for unknown  $V_x$  reported in EN 1990, Annex D, Table D1.

**2.2.18 Tensile behaviour of bent composite system (only with steel fabric)**

Purpose of the test

The purpose of this test is to evaluate possible degradation of the composite system with steel fabric wires when subjected to bending and aggressive environment.

Test method

Table 2.2 shows the geometry and the shape of the fabric coupons. A minimum of five straight fabric specimens and five bent fabric specimens are required as control specimens. Tensile testing to determine the tensile strength of the fabric shall be conducted in accordance with Annex B with deviations as listed in Table 2.2. Tests shall be conducted on primary grid direction. Five coupons of the straight and five coupons of bent configurations shall be then exposed to the saltwater conditioning environment given in Section 2.2.8 followed by testing in direct tension in accordance with Annex B.

**Table 2.2 Testing parameters for the steel fabric in direct tension**

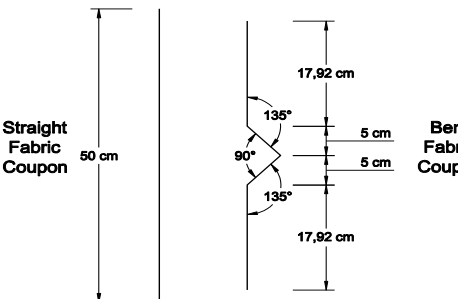
DEVIATIONS FROM ANNEX B	COUPONS SHAPE	NUMBER OF SPECIMENS AND CONDITIONING		
Record only maximum load Specimen width = 2.50 cm (min) Specimen length = 50 cm (min)		Straight specimens	Ambient	5
			Saltwater	5
		Bent specimens	Ambient	5
			Saltwater	5

Assessment

The average (arithmetic mean) and characteristic value of the tensile strengths  $\sigma_{u,f,straight}$  and  $\sigma_{u,f,bent}$  [MPa] in ambient and the average and characteristic value of the tensile strengths  $\sigma_{u,f,straight,sw}$  and  $\sigma_{u,f,bent,sw}$  [MPa] after conditioning shall be determined and reported in the ETA, together with the exposure conditions. The

characteristic value will be determined by using the appropriate value of  $k_n$  for unknown  $V_x$  reported in EN 1990, Annex D, Table D1.

### **2.2.19 Reaction to fire**

The composite system shall be tested, using the test method(s) according to EN 13501-1 relevant for the corresponding reaction to fire class, in order to be classified according to Commission Delegated Regulation (EU) 2016/364.

The performance class obtained from the tests shall be reported in the ETA.

### 3 ASSESSMENT AND VERIFICATION OF CONSTANCY OF PERFORMANCE

#### 3.1 System(s) of assessment and verification of constancy of performance to be applied

For the products covered by this EAD, the applicable European legal act is: **Decision 1999/469/EC**.

The system is: **2+**

In addition, with regard to reaction to fire for products covered by this EAD the applicable European legal act is: **Decision 1999/469/EC**, as amended by **Decision 2001/596/EC**.

The systems are:

- 1 for A1, A2, B, C classes (Products/materials for which a clearly identifiable stage in the production process results in an improvement of the reaction to fire classification, e.g. an addition of fire retardants or a limiting of organic material).
- 3 for A1, A2, B, C classes (Products/Materials for which **there is not** a clearly identifiable stage in the production process resulting in an improvement of the reaction to fire classification) and D, E classes.
- 4 for A1 to E classes (Products/materials that do not require to be tested for reaction to fire, e.g. Products/materials of Classes A1 according to Commission Decision 96/603/EC) and F class.

#### 3.2 Tasks of the manufacturer

The cornerstones of the actions to be undertaken by the manufacturer of the product in the procedure of assessment and verification of constancy of performance are laid down in Table 3.1.

**Table 3.1 Control plan for the manufacturer; cornerstones.**

No	Subject/type of control	Test or control method (*)	Criteria, if any	Minimum number of specimens	Minimum frequency of control
<b>Factory production control (FPC)</b>					
<b>Incoming materials</b>					
1	Incoming materials	Check of delivery ticket or label on the package Supplier documents or supplier tests' check	Conformity with the order	---	Each delivery
2	<u>Incoming materials for fabric only:</u> Geometrical and technological properties of cords ( <i>steel based products</i> )	Supplier documents or supplier tests' check	Conformity with the order	---	Each delivery
3	Planarity of fabric	Visual check	Acc. to the Control Plan	According to tests or control methods	Every batch (***)
4	Parallelism of the yarns/cords of fabric	Visual check / Calliper	Acc. to the Control Plan	According to tests or control methods	Every batch (***)
5	Roll width of fabric	Tape measure	Acc. to the Control Plan	According to tests or control methods	Every batch (***)
6	Mass of fabric	Scale	Acc. to the Control Plan	According to tests or control methods	Every batch (***)

**Table 3.1 Control plan for the manufacturer; cornerstones.**

No	Subject/type of control	Test or control method (*)	Criteria, if any	Minimum number of specimens	Minimum frequency of control
7	Mass of zinc of fabric ( <i>steel based products</i> )	EN 10244-2:2009 or ASTM A475-03(2014)	Acc. to the Control Plan	According to tests or control methods	Every batch (***)
8	Superficial uniformity of galvanization of fabric ( <i>steel based products</i> )	Electron microscope with EDS	Acc. to the Control Plan	According to tests or control methods	Every batch (***)
9	Tensile strength of fabric with respect to the primary directions	Acc. to the Control Plan	Acc. to the Control Plan	According to tests or control methods	Every six months
10	Tensile strength of fabric with respect to the primary directions, after alkali conditioning (immersing specimens in a liquid with pH $\geq$ 9.5 for 3,000 hours at a temperature of 23 $\pm$ 2°C) ( <i>glass based products</i> )	EN ISO 13934-1	Acc. to the Control Plan	According to tests or control methods	Every year
11	Organic content of mortar	Acc. to the Control Plan	Acc. to the Control Plan	According to tests or control methods	Acc. to the Control Plan (**)
12	Bond strength of mortar	Acc. to the Control Plan	Acc. to the Control Plan	According to tests or control methods	Every batch (***)
<p>(*) In all cases, the TAB and the manufacturer may agree to alternative tests or control methods or, where none exist, these parties may agree on the method.</p> <p>(**) The frequency is determined case by case depending on the type of production process, the variation in the volume produced and the production process control.</p> <p>(***) Batch: every quantity of material made in a single operation, or in the case of continuous production for a defined quantity (in linear meter or square meters or tons) which shall be demonstrated by the producer to have a uniform composition and shall not exceed one day's production.</p>					
<p>Note: If a component is covered by an existing HTS, the FPC is deemed to be satisfied by the application of FPC foreseen in the relevant HTS, provided that relevant characteristics as of the control plan, have been achieved. Otherwise, conformity of purchased components with the order shall be established by the kit manufacturer.</p>					

### 3.3 Tasks of the notified body

The cornerstones of the actions to be undertaken by the notified body in the procedure of assessment and verification of constancy of performance for the composite system are laid down in Table 3.2.

**Table 3.2 Control plan for the notified body; cornerstones**

No	Subject/type of control (product, raw/constituent material, component - indicating characteristic concerned)	Test or control method	Criteria, if any	Minimum number of samples	Minimum frequency of control
<b>Initial inspection of the manufacturing plant and of factory production control</b>					
1	The notified body shall ascertain that, in accordance with the control plan, the manufacturing plant of the product manufacturer, in particular personnel and equipment, and the factory production control are suitable to ensure a continuous and orderly manufacturing of the composite system.	As defined in the control plan	As defined in the control plan	As defined in the control plan	At the beginning of the contract between NB and Manufacturer
2	<u>Only for AVCP system 1</u> Initial inspection of the manufacturing plant and of factory production control carried out by the manufacturer regarding the constancy of performance related to reaction to fire, taking into account the limitation on organic material and/or the addition of fire retardant.	As defined in the control plan	As defined in the control plan	As defined in the control plan	At the beginning of the contract between NB and Manufacturer
<b>Continuous surveillance, assessment and evaluation of factory production control</b>					
3	It shall be verified that the system of factory production control and the specified manufacturing process are maintained in accordance with the control plan in order to ensure the constancy of product performance	As defined in the control plan	As defined in the control plan	As defined in the control plan	Once per year
4	<u>Only for AVCP system 1</u> Continuous surveillance, assessment and evaluation of the factory production control carried out by the manufacturer considering the constancy of performances of reaction to fire and taking into account the limitation on organic material and/or the addition of fire retardants.	As defined in the control plan	As defined in the control plan	As defined in the control plan	Once per year



## 4 REFERENCE DOCUMENTS

EN 771-1:2011+A1:2015	Specification for masonry units - Part 1: Clay masonry units
EN 771-6 :2011+A1:2015	Specification for masonry units - Part 6: Natural stone masonry units
EN 772-1:2011+A1:2015	Methods of test for masonry units – Part 1: Determination of compressive strength
EN 998-1:2016	Specification for mortar for masonry – Part 1: Rendering and plastering mortar
EN 998-2:2016	Specification for mortar for masonry – Part 2: Masonry mortar
EN 1504-2:2004	Products and systems for the protection and repair of concrete structures - Definitions, requirements, quality control and evaluation of conformity - Part 2: Surface protection systems for concrete
EN 1504-3:2005	Products and systems for the protection and repair of concrete structures - Definitions, requirements, quality control and evaluation of conformity - Part 3: Structural and non-structural repair
EN 1504-6:2006	Products and systems for the protection and repair of concrete structures - Definitions, requirements, quality control and evaluation of conformity - Part 6: Anchoring of reinforcing steel bar
EN 1504-7:2006	Products and systems for the protection and repair of concrete structures - Definitions, requirements, quality control and evaluation of conformity - Part 7: Reinforcement corrosion protection
EN 1542:1999	Products and systems for the protection and repair of concrete structures - Test methods - Measurement of bond strength by pull-off
EN 1766:2017	Products and systems for the protection and repair of concrete structures - Test methods - Reference concretes for testing.
EN 1881:2006	Products and systems for the protection and repair of concrete structures - Test methods - Testing of anchoring products by the pull-out method
EN 1990:2002/A1:2005	Eurocode - Basis of structural design
EN 1926:2006	Natural stone test methods – Determination of uniaxial compressive strength
EN 2561:1995	Aerospace series - Carbon fibre reinforced plastics - Unidirectional laminates - Tensile test parallel to the fibre direction
EN ISO 6892-1:2016	Metallic materials - Tensile testing – Part 1: Method of test at room temperature
EN 10244-2:2009	Steel Wire And Wire Products - Non-ferrous Metallic Coatings On Steel Wire - Part 2: Zinc Or Zinc Alloy Coatings
EN ISO 13934-1:2013	Textiles -- Tensile properties of fabrics -- Part 1: Determination of maximum force and elongation at maximum force using the strip method
EN ISO 14130:1997	Fibre-reinforced plastic composites - Determination of apparent interlaminar shear strength by short-beam method
ISO 16120-1/4	Non-alloy steel wire rod for conversion to wire
ISO 17832:2018	Non-parallel steel wire and cords for tyre reinforcement
ASTM A475-03(2014)	Standard specification for zinc-coated steel wire strand
ASTM C581-03	Practice for Determining the Chemical Resistance of Thermosetting Resins Used in Glass-fiber-reinforced Structures Intended for Liquid Service.
ASTM D1141-98	Practice for Preparation of Substitute Ocean Water

ASTM D2247-11	Practice for Testing Water Resistance of Coatings in 100% Relative Humidity
ASTM D3045-92(2010)	Standard Practice for Heat Aging of Plastics Without Load
ASTM E104-02	Standard Practice for Maintaining Constant Relative Humidity by Means of Aqueous Solutions

## ANNEX A SUMMARY OF TESTS

**Table A1: Number of tests on the composite system (fabric (A) + inorganic matrix (B))**

	Essential characteristic	TEST TYPE	CONDITIONING	Minimum number of specimens
Mechanical properties	Tensile strength	Direct tension	Laboratory conditions (T=23±2°C , RH=50±5%)	20
	Strain		Under maximum service temperature	5
	Stress-strain curve			
	Interlaminar shear strength	Short-beam	N/A	20
	Lap tensile strength	Direct tension	N/A	10
	Tensile strength after long term actions (creep)	Direct tension	N/A	8
Interaction with substrate	Bond strength on substrate <sup>(1)</sup>	Pull-Off	Ambient (control specimens)	5
			Water (1000 and 3000 hrs)	10
			Saltwater (1000 and 3000 hrs)	10
			Alkali (1000 and 3000 hrs)	10
			<b>TOTAL</b>	<b>35</b>
	Bond strength on substrate <sup>(1)</sup>	Single-lap shear	Ambient (control specimens)	5
			Water (1000 and 3000 hrs)	10
			Saltwater (1000 and 3000 hrs)	10
			Alkali (1000 and 3000 hrs)	10
			Creep	5
			<b>TOTAL</b>	<b>40</b>
	Pull-out from substrate <sup>(1)</sup>	Pull-out	Ambient (control specimens)	5
			Water (1000 and 3000 hrs)	10
			Saltwater (1000 and 3000 hrs)	10
			Alkali (1000 and 3000 hrs)	10
<b>TOTAL</b>			<b>35</b>	
Ageing	Freezing and Thawing	Direct tension	20 freeze-thaw cycles (four hours at -18±2°C followed by 12 hours >95% humidity and 38±2°C)	5
		Interlaminar shear	20 freeze-thaw cycles (four hours at -18±2°C followed by 12 hours >95% humidity and 38±2°C)	5
		<b>TOTAL</b>	<b>10</b>	
	Water resistance	Direct tension	1000 hours	5
			3000 hours	5
		Interlaminar shear	1000 hours	5
			3000 hours	5
		1000 hours	5	

	Essential characteristic	TEST TYPE	CONDITIONING	Minimum number of specimens
		Lap tensile strength	3000 hours	5
			<b>TOTAL</b>	<b>30</b>
	Saltwater resistance	Direct tension	1000 hours	5
			3000 hours	5
		Interlaminar shear	1000 hours	5
			3000 hours	5
		Lap tensile strength	1000 hours	5
			3000 hours	5
		<b>TOTAL</b>	<b>30</b>	
	Alkali resistance	Direct tension	1000 hours	5
			3000 hours	5
		Interlaminar shear	1000 hours	5
			3000 hours	5
		Lap tensile strength	1000 hours	5
			3000 hours	5
		<b>TOTAL</b>	<b>30</b>	
	Alkali soil resistance	Direct tension	1000 hours	5
			<b>TOTAL</b>	<b>5</b>
	Dry heat resistance	Direct tension	1000 hours	5
			3000 hours	5
			<b>TOTAL</b>	<b>10</b>
	Fuel resistance	Direct tension	4 hours minimum	5
			<b>TOTAL</b>	<b>5</b>
<b>Cyclic loading</b>	Tensile strength after low number of cycles (seismic behaviour)	Direct tension	N/A	<b>5</b>
	Tensile strength after high number of cycles (fatigue actions)	Direct tension	N/A	<b>5</b>
<b>Notes:</b>				
(1) These tests are to be repeated for each substrate foreseen by the intended use of the product (concrete, clay and natural stone masonry)				

**Table A2: Number of tests on the fabric (A)**

	<b>Essential characteristic</b>	<b>TEST TYPE</b>	<b>CONDITIONING</b>	<b>Minimum number of specimens</b>
<b>Mechanical properties</b>	Conventional limit properties of composite system	Direct tension	N/A	5
	Tensile behaviour on bent composite system ( <i>only with steel fabrics</i> )	Direct tension on straight specimens	Ambient	5
			Saltwater	5 for each duration
		Direct tension on bent specimens	Ambient	5
			Saltwater	5 for each duration

## **ANNEX B TENSILE TESTING OF COMPOSITE SPECIMENS**

This test procedure is designed to produce tensile property data for material specifications, quality assurance, and structural design and analysis.

### **B1. Summary of Test Method**

A thin flat strip of material having a near-constant rectangular cross section is mounted in the grips of a mechanical testing machine and loaded with monotonically increasing displacement while recording load and movement. The ultimate strength of the material can be determined from a maximum load carried before failure. The coupon strain or elongation is monitored with displacement transducers to determine the nominal stress-strain response of the material, and from that the cracking stress and strain, ultimate tensile strain, tensile stiffness modulus before and after cracking of cement-based matrix can be derived.

### **B2. Apparatus**

The testing machine shall have the appropriate load capacity to withstand the foreseen ultimate forces and must be equipped with an appropriately calibrated load cell and classifiable at least in class 1 with reference to EN ISO 6892-1 (resolution higher than 0.1 %).

The testing machine shall be equipped with a gripping system which allows to lock the ends of the specimens by applying them a sufficient lateral pressure to prevent the slippage of the specimen with respect to the grips and the sliding of the mesh inside the matrix. If necessary, appropriate arrangements will be made to prevent it, for example by holding the mesh wires at the ends of the specimen by means of suitable metallic clips.

It is desirable to use grips that are rotationally self-aligning to minimize bending stresses in the specimen.

The accuracy of instruments used for measuring dimensions of the test specimens shall be suitable for reading to within 1 percent of the sample dimensions.

### **B3. Test Specimen and Sampling**

Specimens can be produced individually by using special moulds or can be cut from larger panels, by using the materials (fabrics and mortars) supplied by the manufacturer.

The materials (fabrics and mortars) supplied by the manufacturer shall be used to produce the specimens via a wet lay-up procedure.

If specimens are produced individually, special moulds made of Plexiglas (or Teflon or other easily disassembling material) with the final dimensions of the specimen shall be made.

If specimens are cut from larger panels, the rectangular panel moulds can be made by attaching a Plexiglas (or Teflon or other easily disassembling material) surface to a particle board and installing aluminium edges to control panel thickness.

The composite large panels (or single coupons) shall be manufactured by using a manual impregnation technique in the mould by first applying a thin layer of the mortar, followed by a layer of the fabric, pre-cut to the panel (or single mould) size, which shall be pushed within the fresh mortar. The top layer of mortar shall be then applied as flat as possible with a finishing trowel. Individual coupons shall be then cut from the large panels by using, for example, a diamond-tipped wet saw with a rigid fixture to ensure consistent specimen widths.

Control of fibre grid alignment is critical in lay-up procedure. Effective cutting tools and methods need to be used, and precautions shall be taken to avoid notches, undercuts, uneven surfaces, or delamination. The specimen preparation method shall be recorded.

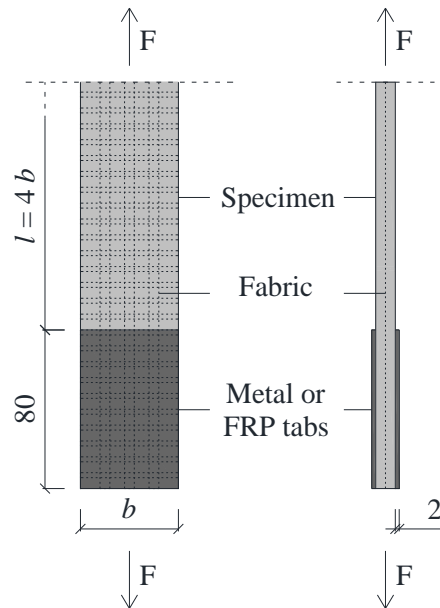

Figure B1: Geometry of specimens and tabs (minimum dimensions). Dimensions in mm.

Test specimen shall be rectangular. Their width shall be such to include at least two grid openings (minimum 3 threads) and shall not be less than four times the spacing of the grid. The thickness of coupons shall be a function of number of layers and thickness of matrix for each layer. In case the strands in multiple layers are staggered with respect to each other, it is preferable to have the same number of strands in each layer along the width of the coupon. The width of the specimen must not be greater than that of the traction machine grips, otherwise a uniform distribution of normal tensile stresses would not be ensured in the specimen.

The minimum length of the coupon, excluding the gripping length, shall be at least four times the width of the specimen. Longer lengths are preferable to minimize the effect of anchors.

Samples should be equipped with tabs in the gripping area to avoid failure of specimens in such zone (Figure B1). The tabs can be metallic (aluminium or steel) or made of fibre reinforced polymers (e.g., GFRP). Tabs (two at each end, one at each face) shall have the same width as the specimen and are glued to it by using an adequate adhesive. It is necessary to respect the time and environmental conditions for the complete curing of the adhesive before carrying out the test.

A minimum tab length of 80 mm is recommended. The thickness of the tabs shall be adequate to uniformly distribute the gripping force to the overall width of the samples. A minimum thickness of 2 mm is recommended.

To avoid dispersion of results, care must be taken to prepare the specimens, to grip them and to align the specimen in the test machine. Non-alignment of fibres causes a non-homogeneous distribution of stresses among the yarns that constitute the fabric sample. In addition, an inappropriate gripping system may cause failure of the test pieces at the ends or a partial break of filaments and, consequently, a relevant dispersion of the results.

#### Curing of specimens

Samples to be tested shall have a maturation period of at least 14 days from the date of preparation. Preservation of specimens must be carried out in standard laboratory atmospheric conditions ( $23\pm 2^\circ\text{C}$ , atmospheric pressure,  $50\pm 5\%$  RH).

## B4. Test procedure

After conditioning and before testing, coupon type and geometry and environmental conditioning test parameters are specified. The width and thickness are measured at three locations along the specimen and averaged.

The specimen shall be placed in the grips of testing machine, taking care to align the axis of the gripped specimen with the testing machine axis. During the test preparation phase, an axial force not greater than 5% of the anticipated failure load can be applied to avoid potential bending effects in the specimen.

The load shall be applied under displacement control, with a constant rate not exceeding 0.2 mm/min in the non-cracked phase (A) and crack formation phase (B) (Figure B2). The rate can be increased up to 0.5 mm/min at the end of the cracked stage.

A suitable instrument for strain measurement (extensometer) shall be attached to the specimen, with a minimum gage length of 200 mm.

During the test, the load value, the displacement of the moving end and the deformation of the extensometer shall be recorded continuously or at frequent regular intervals.

The stress value is defined as the ratio of the load and the fabric cross-sectional area  $A_{f,tot}=n A_f$ , where  $n$  is the number of yarns and  $A_f$  is the cross sectional area of the single yarn.

The displacement transducer could be removed before anticipated failure to avoid damage to the sensor, but load readings shall continue until failure.

The maximum load and corresponding displacements at, or as near as possible to, the moment of rupture shall be recorded, along with the failure mode and location.

## B5. Calculation

**B5.1 Expected Tensile Stress – Strain Curve:** The recorded data will likely result in a near trilinear response curve (Figure B2) with an initial line for uncracked specimen (Stage A), a secondary line for cracked specimen (Stage C), and possibly a curved transition segment in between (Stage B – crack formation). The expected tensile stress,  $\sigma_f$ , versus tensile strain,  $\epsilon_f$ , curve of a composite coupon specimen is shown in Figure B2. In particular, the ultimate values are:

$\sigma_u$  = ultimate stress obtained in the test in correspondence of the peak force value [MPa];

$\epsilon_u$  = ultimate strain obtained in the test at the peak force value [%].

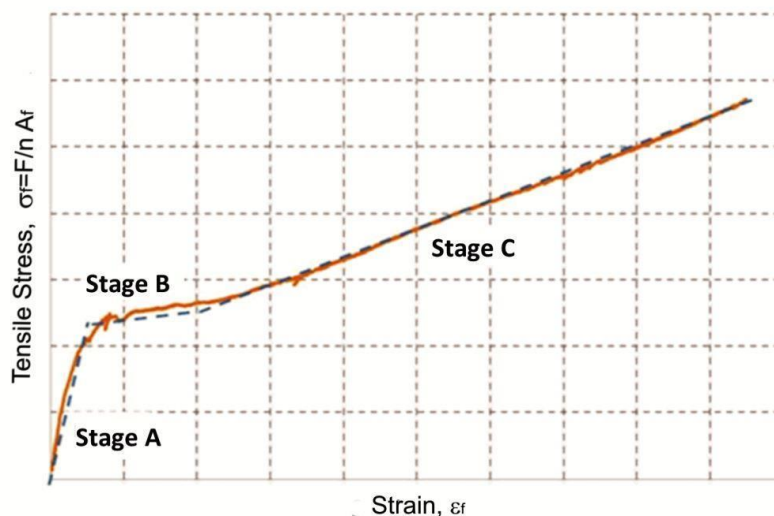

Figure B2: Example of tensile stress-strain curve.



**B5.2 Tensile stiffness modulus of un-cracked specimen (Stage A):**

On the linear segment of the initial line of the stress-strain curve corresponding to un-cracked behaviour of the specimen (stage A) two points connecting the results in a line that closely follows the trend and slope of the response curve at that region are selected. The tensile stiffness modulus of the un-cracked specimen  $E_1$  is calculated using:

$$E_1 = \Delta\sigma_f / \Delta\varepsilon_f$$

where:

$\Delta\sigma_f$  = difference in tensile stress between two selected points [MPa].

$\Delta\varepsilon_f$  = difference in tensile strain between two selected points [%].

**B5.3 Tensile stiffness modulus of cracked specimen (Stage C):**

On the linear segment of the stress-strain curve corresponding to cracked behaviour of the specimen two points connecting the results in a line that closely follows the trend and slope of the response curve at that region are selected. The tensile stiffness modulus of the cracked specimen  $E_3$  is calculated using:

$$E_3 = \Delta\sigma_f / \Delta\varepsilon_f$$

**B6. Report**

The following information shall be reported to the maximum extent applicable:

- Date and location of the test
- Identification of the material tested including material specification, type, and designation, manufacturer
- Orientation of the fibre grid
- Area of grid reinforcement by unit width and nominal cross-section area of all specimens
- Method of preparation of test specimen including labelling system, geometry, sampling method, cutting, tab identification, geometry and adhesive used
- Description of the test machine
- Conditioning parameters and results
- Temperature and humidity of testing laboratory
- Number of specimens tested
- Speed of testing
- Type and placement of transducers on the test specimens
- Stress-strain curve and tabulated results
- Individual strengths, average, standard deviation, and coefficient of variation (in percent) for the population
- Individual strains at failure and average, standard deviation, and coefficient of variation (in percent) for population
- Stress and strain used for modulus calculation
- Individual moduli of elasticity and average, standard deviation, and coefficient of variation (in percent) for population
- Failure mode and location of failure for each specimen

## ANNEX C SINGLE-LAP SHEAR TEST

This test method describes the apparatus and procedure for evaluating the bond properties of composite systems adhesively applied to a flat concrete or masonry substrate.

### C1. Summary of Test Method

The direct single-lap shear test is conducted using a push-pull configuration, where the substrate prism with square or rectangular cross-section is restrained while the composite strip is pulled until failure.

### C2. Apparatus

Tests are conducted using a direct single-lap shear test set-up. The prism is restrained against movement by two steel plates placed against the square or rectangular end cross-sections of the prism. The bottom square plate shall be gripped to the testing machine. The top plate is a rectangular or C-shaped steel element connected to the bottom one through four steel bars bolted to the two plates. In case of masonry, the top plate shall be positioned at a minimum distance of 40 mm from the edge of the masonry block (Figure C1), to avoid that compression induced by the top plate can influence the stress state in correspondence of the bonded composite.

The displacement and the applied load have to be recorded continuously during the test.

Slip measurement—Linear variable differential transducers (LVDTs) can be mounted on the substrate surface close to the top edge of the bonded region to measure the displacement of the strip with respect to the substrate (an example is shown in Figure C1). The LVDTs (named LVDT a and b in Figure C1) react off of a thin aluminium  $\Omega$ -shaped plate bonded to the bare fibres immediately outside the bonded length.

*Optional rotation measurement*—Two optional LVDTs (named LVDT c and d in Figure C1) can be used to monitor the horizontal displacement of the substrate in the direction perpendicular to the face of the composite strip. The LVDT c and d react off of the face of the substrate block parallel to the one to which the composite is applied. The measurement point should be approximately at half of the length of the substrate.

### C3. Test Specimen and Sampling

#### Concrete

The concrete test specimen shall conform to all requirements of EN 1766, considering an MC (0,40) concrete type. The dimensions of the concrete prism shall be 150 mm width  $\times$  150 mm depth  $\times$  450 mm length. Dimensions of the prism can be varied as long as the indicated dimensions are considered the minimum values admissible. The sides of the specimen shall be at right angles with the top and bottom. All surfaces shall be smooth and free of scars, indentations, holes, or inscribed identification marks. The prisms are reinforced on one face (neither the casting one nor the end cross-sections shall be used) with bonded reinforcement. Because the formed faces of the concrete prism might have a different amount of aggregates near the surface, the position of the face used to apply the composite with respect to the casting one shall be clearly identified in the report.

Surface preparation of the specimen face that will receive the composite system shall be in accordance with the manufacturer's requirements of the system being tested. Details of the surface preparation shall be recorded with the test data.

The distance  $d_1$  between the beginning of the bonded area and the top edge (at loaded end of the composite strip) of the concrete prism shall be minimum 40 mm to avoid spalling of concrete. Bond breaking is easily accomplished using, for example, masking tape that covers the concrete surface from the top edge to the beginning of the bonded area.

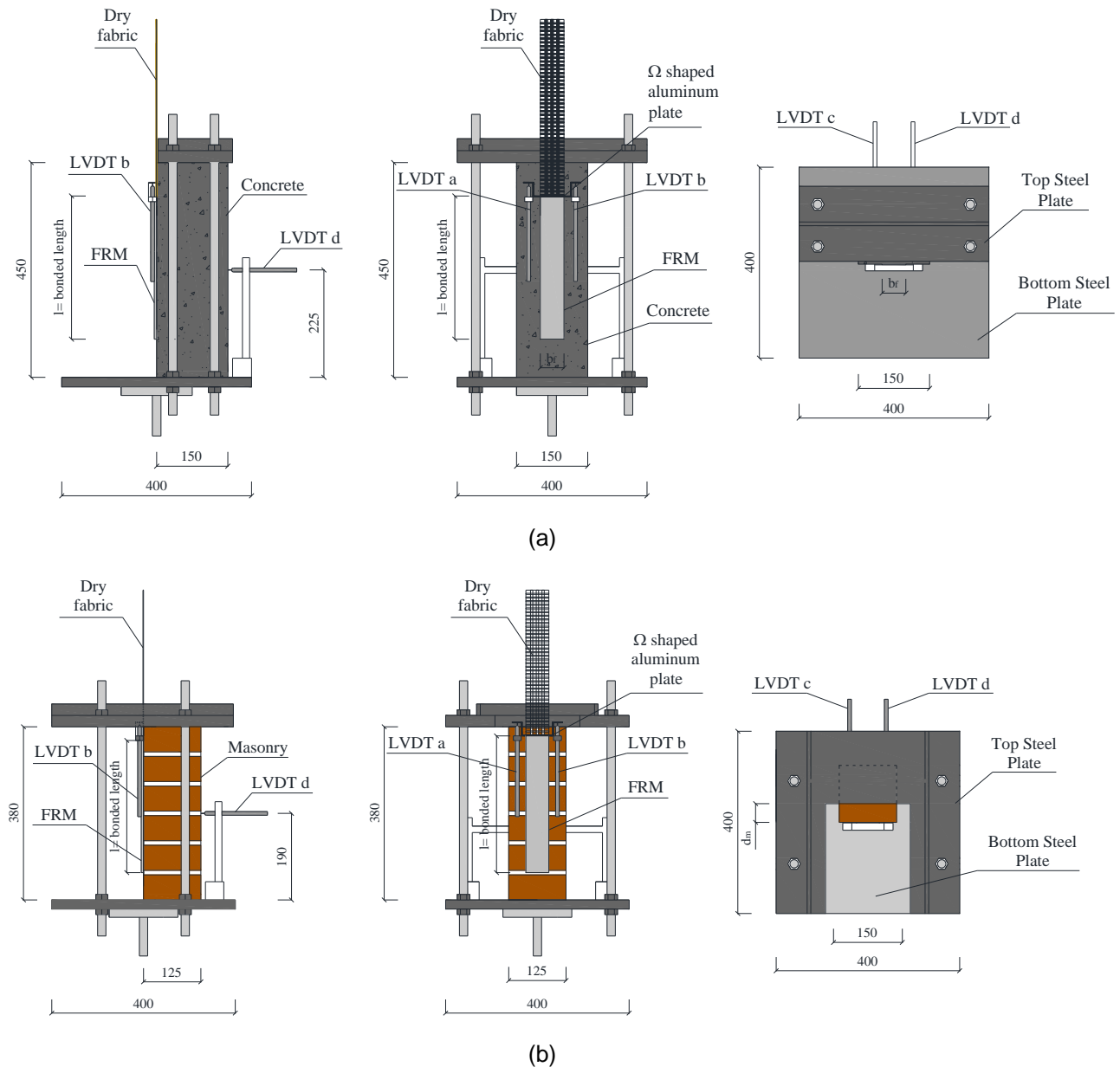

Figure C1: Schematic of Suitable Apparatus for Direct Single-Lap Shear Test. Example for: (a) concrete specimens and (b) masonry specimens.

### Masonry

Test shall be performed on masonry made of bricks compliant with EN 771-1 (clay) or EN 771-6 (natural stone) (see Section 2.2.4 for details). Masonry shall be composed of layers of bricks so that the total length is at least 380 mm. In case of natural stone, the number of layers shall be comprised between 3 and 6. The thickness of the mortar shall be 10 mm. The width of the face where the reinforcement is applied shall be of at least 125 mm.

Surface preparation of the specimen face that will receive the composite system shall be in accordance with the manufacturer's requirements of the composite system being tested. Details of the surface preparation shall be recorded with the test data.

The distance  $d_f$  between the beginning of the bonded area and the top edge (at loaded end of the composite strip) of the masonry element shall be 20 mm. Bond breaking is easily accomplished using, for example, masking tape that covers the masonry surface from the top edge to the beginning of the bonded area.

### Composite system

The composite system applied to one face of the specimen shall meet the following requirements as shown in Figure C2 and Figure C3:

- The composite system shall be applied in accordance with the manufacturer's recommended procedure. The manufacturer's instructions should be followed as to the elapsed time between composite system application and testing.
- The width of the applied composite system  $b_f$  shall be such to include at least two grid openings (minimum 3 threads) and shall not be less than four times the spacing of the grid. The composite system shall be centred on the strengthened face of the substrate.
- The bonded length of the applied composite system should be equal to 300 mm. The composite system shall be centred on the strengthened face of the substrate.
- Outside the bonded area, fibres may be covered by matrix until the edge of the substrate and left bare in the overhang length; two tabs can be bonded to the end of the bare fabric to improve gripping during testing.
- The strip will be longer than the bonded length  $l$ . The total length  $L_f$  of the composite strip shall be computed in accordance to Equation (1):

$$L_f = l + d_f + 300 \text{ mm} \quad (1)$$

The overhang length can be reduced if the testing machine does not allow to fit long strips, but cannot be less than 150 mm.

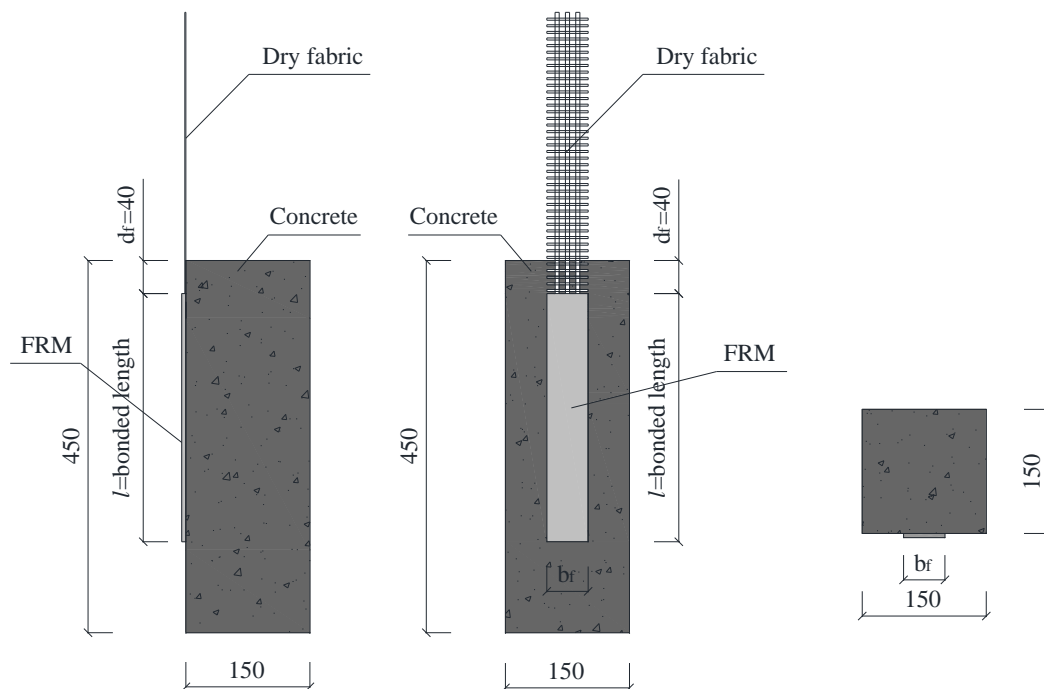

Figure C2: Specimen Dimensions and Details of Bonded composite system (concrete specimens).

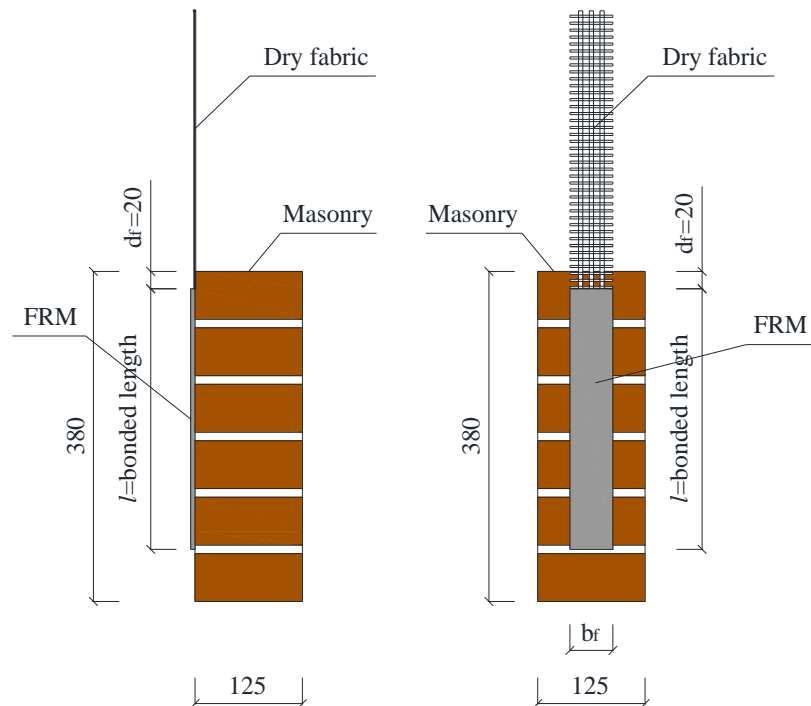

Figure C3: Specimen Dimensions and Details of Bonded composite system (masonry specimens).

#### C4. Test Procedure

1. Centre the specimen in order to have the composite strip perfectly aligned with the clamping wedge.
2. Apply an initial pre-compression to the support by tightening the bolts of the four steel bars used to connect the top and bottom plates. The total pre-compression force applied to the four steel bars shall be measured using a torque wrench. The total pre-compression shall be not greater than one fourth of the maximum applied load expected. In addition, the total force applied to the four steel bars divided by the cross-sectional area of the prism shall provide a stress that is lower or equal to one tenth of the compressive strength of substrate.
3. Clamp the loaded end of the strip within the wedges of the testing machine. Slowly adjust the position of the head of the machine so that no force is applied to the strip prior to testing when the strip is firmly clamped.
4. Pull the strip in displacement control, increasing the displacement of the machine stroke continuously and without shock. The displacement shall be increased at a constant rate equal to 0.2 mm/min.
5. Perform the test in stroke until the composite strip completely debonds from the substrate.
6. The expected load response in terms of applied load versus global slip,  $g$  measured by LVDT a and b of Figure C1, shall resemble the idealized response of Figure C4, which is characterized by an initial linear branch followed by a non-linear branch up to the onset of debonding, which corresponds to the debonding load  $P_{deb}$ . The maximum force  $P_{max}$  corresponds to the maximum applied force.
7. The conventional limit stress  $\sigma_{lim,conv}$  is determined as the ratio between the maximum force  $P_{max}$  and the fabric cross sectional area  $A_{f,tot}$ .

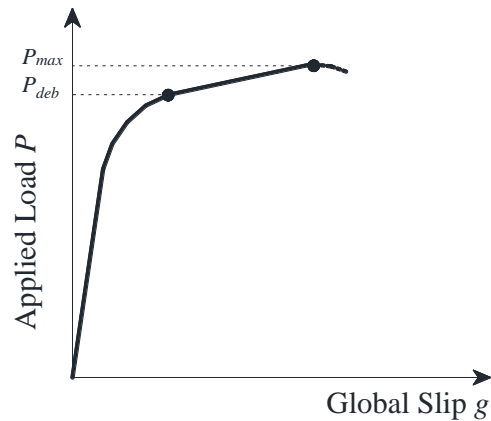

Figure C4: Example of load-displacement curve.

## C5. Report

Report the following information to the maximum extent applicable:

### Test Parameters

- Date of test, test temperature and relative humidity.
- Length of composite system to the nearest 1 mm for each specimen.
- Width of composite system to the nearest 1 mm for each specimen.
- Distance between the beginning of the bonded area and edge of substrate to the nearest 1 mm for each specimen.

### Test Results —Provide results for each test and average and statistics for sample population.

- Maximum applied force  $P_{max}$  in N for each specimen.
- Maximum measured displacement in mm for each specimen.
- Global slip measurement corresponding to the maximum applied force—the average measurement obtained from LVDT a and b, named global slip,  $g$ , shall be calculated for each specimen.
- Out of plane displacement corresponding to the maximum applied force measurement— If LVDT c and d are used, the obtained values shall be reported for each specimen.
- The load-global slip response shall be reported.
- Failure mode for each specimen.
- Bond capacity  $P_{deb}$  and coefficient of variation
- Corrections made to data including test values omitted from calculated average and basis for omitting test values (such as failure mode). Note any other deviations from the procedure.

## ANNEX D PULL-OUT TEST

### D1. Test specimens

#### Concrete

The concrete test blocks shall be cast from concrete type MC (0,40) as specified in EN 1766. The dimensions of the concrete prism shall be 150 mm width × 150 mm depth × 300 mm length.

A hole of 20 mm diameter and 250 mm depth shall be drilled by a rotary percussive or diamond drill, as specified by the manufacturer, in the centre of the cast (150 x 150) mm face of the block.

Immediately after the drilling operation the hole shall be cleaned in accordance with manufacturer's instructions and the test block shall then be placed in its required orientation and the anchoring operation may be undertaken.

#### Masonry

Masonry bricks and mortar shall comply with the indications given in 2.2.4. A one brick wall with dimensions of minimum 250 mm width × 250 mm depth × 300 mm height shall be built.

A hole of 20 mm diameter and 250 mm depth shall be drilled in the middle of the mortar joint.

Immediately after the drilling operation the hole shall be cleaned in accordance with the manufacturer's instructions and the test block shall then be placed in its required orientation and the anchoring operation may be undertaken.

#### Composite system

Fabric coupons 100 mm large and 600 mm long and shall be cut from larger panels. One terminal edge of the fabric, through adequate operations indicated by the manufacturer, shall be rolled in order to obtain a single cylinder that will be used as a connector for the intended anchoring operation. The mortar shall be prepared and placed, and the composite system installed, strictly in accordance with the manufacturer's Instructions. The other end shall be left as plane fabric in order to apply the tensile force.

### D2. Apparatus

The test set-up is in deviation from the one presented in EN 1881. The concrete or masonry elements shall be restrained against movement in order to allow the application of a tensile force to the free end of the composite system, through an apparatus similar to the one used for tensile testing.

### D3. Test procedure

Test procedure shall follow the general prescriptions of EN 1881, with the exception that a displacement rate of 1 mm/min shall be used until failure.

## ANNEX E TENSILE TESTING OF DRY FABRIC

The tensile test on dry fabric samples is carried out to define the stiffness and strength of the fabric in order to determine the conventional limit properties of the composite system.

### E1. Test summary

A thin flat strip of dry fabric having a near-constant rectangular cross section is mounted in the grips of a mechanical testing machine and loaded with monotonically increasing load in tension while recording load and movement. The ultimate strength of the fabric can be determined from a maximum load carried before failure. The coupon strain or elongation is monitored with strain gauges to determine the nominal stress-strain response of the material, from which the tensile modulus of elasticity can be also derived.

### E2. Apparatus

The testing machine shall have the appropriate load capacity to withstand the foreseen ultimate forces and must be equipped with an appropriately calibrated load cell and classifiable at least in class 1 with reference to EN ISO 6892-1.

The testing machine shall be equipped with a gripping system which allows to lock the ends of the sample by applying them a sufficient lateral pressure to prevent the slippage of the specimen. It is desirable to use grips that are rotationally self-aligning to minimize bending stresses in the coupon. Strain/elongation measurements shall be made with an extensometer applied to the fabric.

### E3. Test specimens

The fabric used to make the samples must be identical to that used for the composite system. If the fabric is supplied with an organic coating, this must also be present in the tested specimens. Conversely, if the reinforcement mesh is not provided of any coating, the fabric shall not be impregnated with any substance.

The test is carried out in displacement control on a fabric sample comprising a number of yarns (bundle of filaments or cords in the case of metallic meshes) equal to that of the specimens used for tensile testing of composite (Figure B1).

The width of the specimen must not be greater than that of the tensile machine grips. Otherwise, uniform distribution of stresses in the specimen would not be assured.

The minimum length of the specimen, excluding the portions required for grips, must be at least 4 times the width of the specimen.

Samples should be equipped with tabs in the gripping area to ensure homogeneous distribution of stresses. The tabs can be metallic (aluminium or steel), made of fibre reinforced polymers (e.g., GFRP) or of thick cardboard.

Tabs (two at each end, one at each face) shall have the same width as the specimen and are glued to it by using an adequate adhesive. The tab length can be calculated based on the maximum expected tensile load and on the strength of the adhesive between the tab and the specimen. A minimum tab length of 50 mm is recommended. The thickness of the tabs shall be adequate to distribute uniformly the gripping force to the overall width of the samples. A minimum thickness of 2 mm is recommended.

To avoid dispersion of results, care must be taken to prepare the specimens, to grip them and to align the specimen in the test machine. Non-alignment of fibres causes a non-homogeneous distribution of stresses among the yarns that constitute the fabric sample. In addition, an inappropriate gripping system may cause failure of the test pieces at the ends or a partial break of filaments and, consequently, a relevant dispersion of the results.



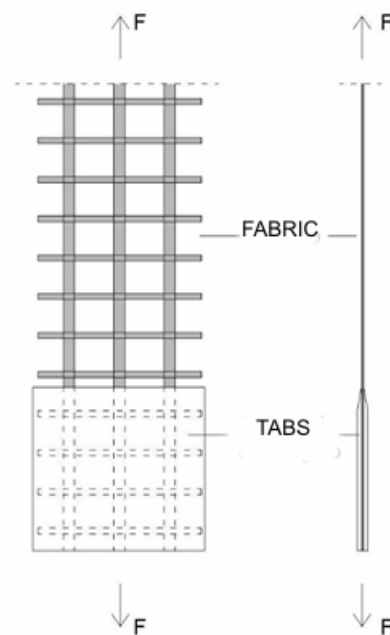

Figure E1: Geometry of fabric samples and tabs.

#### Determination of sample section

The fabric cross sectional area can only be determined after calculating the area of the single yarn through the weight of its part. The length of this section is evaluated based on the resolution of the instrument used to determine its weight (at least 0.01g resolution). The area must be calculated for the single yarn, and multiplied by the number of yarns in the sample. The area of a single yarn ( $A_f$ ), expressed in  $\text{mm}^2$ , is calculated as:

$$A_f = \frac{P_{\text{yarn}}}{\rho l_{\text{yarn}}} 1000$$

Where

- $p_{\text{yarn}}$  is the yarn weight [g]
- $l_{\text{yarn}}$  is the yarn length [mm]
- $\rho$  is the fibre density [ $\text{g}/\text{cm}^3$ ]

#### **E4. Test procedure**

The specimen must be placed in the grips of the testing machine, paying particular attention to its alignment with the axis of the machine. During the test preparation phase, an axial force not greater than 5% of the anticipated failure load can be applied to the specimen in order to align the specimen.

The load shall be applied under displacement control, with a constant rate not exceeding 0.5 mm/min.

A suitable instrument for strain measurement (extensometer) shall be attached to the specimen, with a minimum gage length of 25 mm.

During the test, the load value, the displacement of the moving end and the deformation of the extensometer shall be recorded continuously.

The stress value is defined as the ratio of the load and the fabric cross-sectional area  $A_{f,\text{tot}}$ , calculated by multiplying the area  $A_f$  for the number of yarns  $n$  ( $A_{f,\text{tot}}=n A_f$ ).

For each test, the value of the ultimate stress  $\sigma_{u,f} = F_u / n A_f$  (where  $n$  indicates the number of yarns) and the elastic modulus  $E_f$  shall be determined. The latter must be determined following the EN 2561 procedure for fibre-reinforced materials, i.e. referring to the stresses and deformations measured in the range  $F_u/10$  and  $F_u/2$ .

The reference values to be used to define the stress-strain curve are the arithmetic mean of the  $E_f$  values obtained from all the tests and the characteristic value of the ultimate stress  $\sigma_{u,f}$ .

The conventional limit strain  $\varepsilon_{lim,conv}$  is defined as the abscissa of the point that, on the average stress-strain curve, has  $\sigma_{lim,conv}$  (Annex C) as ordinate (Figure E2).

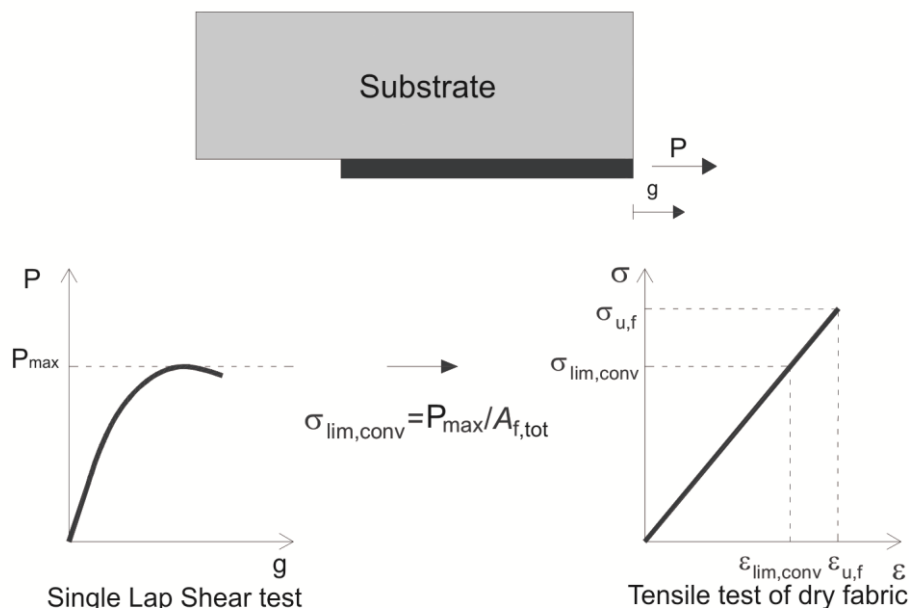

Figure E2: Evaluation of the conventional limit strain  $\varepsilon_{lim,conv}$ .

## E5. Report

The following information shall be reported:

- Date and location of the test
- Identification of the materials tested including material specification, type and designation, manufacturer
- Size of the specimen
- Description of the sample preparation
- Orientation of samples with respect to the two directions of the mesh (weft and warp)
- Conditioning parameters
- Environmental conditions of the test (temperature and relative humidity)
- Number of specimens
- Sample alignment and gripping system used
- Test speed
- Type and location of transducers used to measure deformation
- Results of the test
- Stress-strain curve and tabulated results