

## EUROPEAN ASSESSMENT DOCUMENT

EAD 040089-00-0404

June 2016

# ETICS WITH RENDERINGS FOR THE USE ON TIMBER FRAME BUILDINGS

The reference title and language for this EAD is English. The applicable rules of copyright refer to the document elaborated in and published by EOTA.

This European Assessment Document (EAD) has been developed taking into account up-to-date technical and scientific knowledge at the time of issue and is published in accordance with the relevant provisions of Regulation (EU) No 305/2011 as a basis for the preparation and issuing of European Technical Assessments (ETA).

## Contents

<b>1. SCOPE OF THE EAD .....</b>	<b>4</b>
1.1 Description of the construction product .....	4
1.2 Information on the intended use(s) of the construction product .....	5
1.2.1 Intended use.....	5
1.2.2 Working life/Durability .....	6
1.3 Specific terms used in this EAD .....	7
1.3.1 Substrate .....	7
1.3.2 Adhesive and base coat .....	7
1.3.3 Insulation product .....	7
1.3.4 Rendering system.....	7
1.3.5 Mechanical fixing devices.....	8
1.3.6 Ancillary materials .....	8
<b>2. ESSENTIAL CHARACTERISTICS AND RELEVANT ASSESSMENT METHODS AND CRITERIA.....</b>	<b>9</b>
2.1 Essential characteristics of the product .....	9
2.2 Methods and criteria for assessing the performance of the product in relation to essential characteristics of the product .....	11
2.2.1 Safety in case of fire.....	11
2.2.2 Hygiene, health and the environment of ETICS and its components .....	12
2.2.3 Safety in use.....	20
2.2.4 Protection against noise .....	39
2.2.5 Energy economy and heat retention .....	40
<b>3. ASSESSMENT AND VERIFICATION OF CONSTANCY OF PERFORMANCE .....</b>	<b>42</b>
3.1 System(s) of assessment and verification of constancy of performance to be applied .....	42
3.2 Tasks of the manufacturer .....	42
3.3 Tasks of the notified body .....	44
3.4 Special methods of control and testing used for the verification of constancy of performance .....	44
3.4.1 Adhesives (except for foam adhesives), base coats, key coats and finishing coats .....	44
3.4.2 Foam adhesive .....	48
3.4.3 Insulation product .....	50
3.4.4 Reinforcement .....	51
3.4.5 Mechanical fixing devices.....	51
<b>4. REFERENCE DOCUMENTS .....</b>	<b>52</b>
<b>ANNEX A REACTION TO FIRE TESTING OF ETICS WITH RENDERING FOR THE USE ON TIMBER FRAME BUILDINGS .....</b>	<b>54</b>
<b>ANNEX B RECOMMENDATIONS FOR CHOOSING THE TESTS TO BE PERFORMED IN ORDER TO ASSESS THE WATER TIGHTNESS OF THE ETICS.....</b>	<b>63</b>
<b>ANNEX C ANALYSIS OF SIMULATED DRIVEN RAIN TEST RESULTS .....</b>	<b>64</b>

## 1. SCOPE OF THE EAD

### 1.1 Description of the construction product

This EAD deals with External Thermal Insulation Composite Systems (ETICS) with renderings to be applied on timber frame buildings. The insulation products are limited to EPS (hEN 13163), XPS (hEN 13164), PU (hEN 13165), PF (hEN 13166), ICB (hEN 13170), MW (hEN 13162), WW (hEN 13168) and WF (hEN 13171).

The walls of common timber frame buildings can be with or without external boards. The prefabricated insulation products are either mounted on external boards – purely bonded or bonded and mechanically fixed – or directly mechanically fixed on timber frame (e.g. WW/WF - but only if they do not contribute to mechanical stability of the buildings). The external boards can be wood based panels, solid wood panels, cement bonded boards, fibre-cement panels, plasterboards, gypsum bonded boards, fibre-gypsum panels, and similar products.

1. Wood-based panels (organic bonding)
2. Cement bonded particle boards
3. Fibre-cement panels (cement bonded fibre boards)
4. Gypsum bonded particle boards
5. Gypsum plaster boards
6. Fibre-gypsum panels (gypsum bonded fibre boards).

The mechanically fixings can be anchors, staples, screws, vertical and/or horizontal profiles, special pieces, etc...., or a combination of adhesive and mechanical fixings. The insulation product is faced with a rendering consisting of one or more layers, one of which contains reinforcement. The rendering is applied directly to the insulating panels, without any air gap or disconnecting layer. The ETICS can be totally site applied or partially factory applied with joints completed on site.

The ETICS include special fittings (e.g. base profiles, corner profiles, ...) to connect them to adjacent building structures (apertures, corners, parapets, etc, ...).

ETICS are designed and installed in accordance with the ETA Holder's design and installation instructions. The ETICS comprises components which are factory-produced by the ETA-holder or by the components' suppliers.

ETICS using other facings such as brick slips or tiles are not covered by this EAD.

ETICS where the connection between rendering and insulation product has no function in their behaviour are not covered by this EAD.

The product is not covered by a harmonised European standard (hEN).

Concerning product packaging, transport, storage, maintenance, replacement and repair, it is the responsibility of the manufacturer to undertake the appropriate measures and to advise his clients on the transport, storage, maintenance, replacement and repair of the product as he considers necessary.

It is assumed that the product will be installed according to the manufacturer's instructions or (in absence of such instructions) according to the usual practice of the building professionals.

Relevant manufacturer's stipulations having influence on the performance of the product covered by this European Assessment Document shall be considered for the determination of the performance and detailed in the ETA.

Examples of ETICS for with renderings for the use on timber frame buildings are given in the following Figure 1:

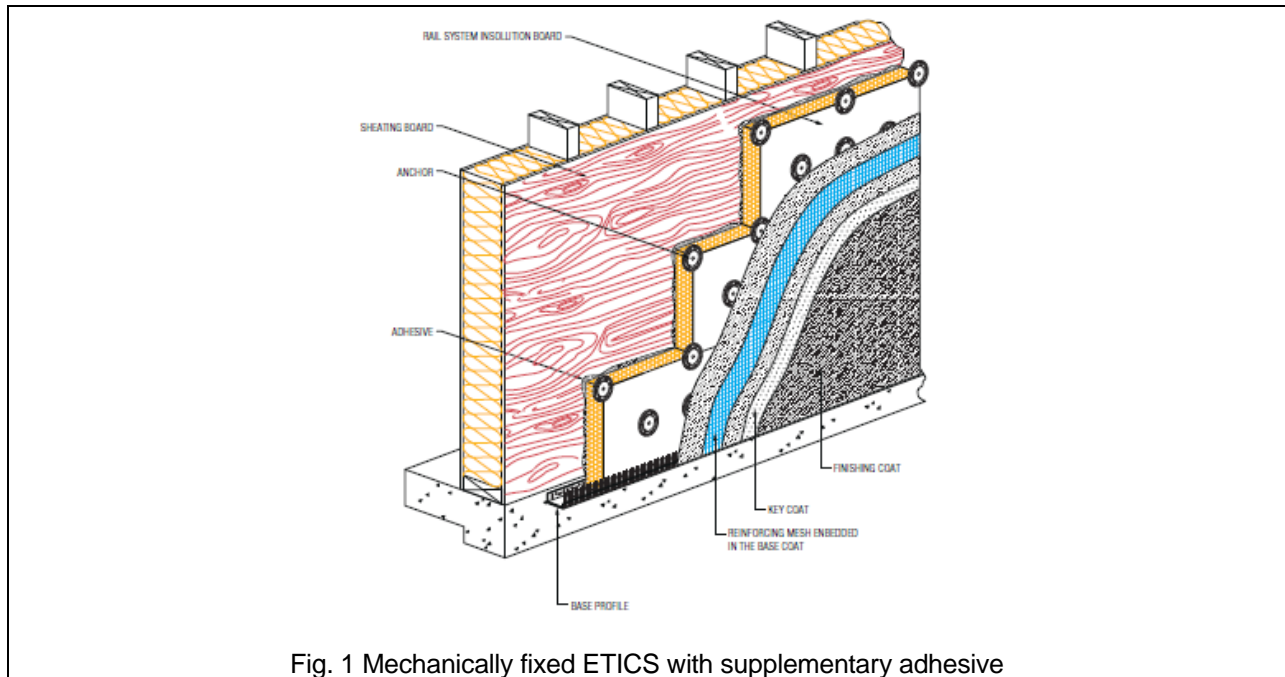

Fig. 1 Mechanically fixed ETICS with supplementary adhesive

## 1.2 Information on the intended use(s) of the construction product

### 1.2.1 Intended use

The ETICS are designed to give the timber frame building wall to which they are applied additional thermal insulation and protection from effects of weathering.

The ETICS can be used on new or existing (retrofit) vertical timber frame building walls. They can also be used on horizontal or inclined surfaces which are not exposed to precipitation.

The surface for the application of ETICS can be a board substrate (wood based panels, solid wood panels, plasterboards, gypsum bonded boards, cement bonded boards, etc).

The board substrate must be suitable for humid conditions as specified in EN 13986.

If the insulation layer of the ETICS is WW according to hEN 13168 or WF according to hEN 13171, the insulation product can also be mounted direct to the timber frame but it must be guaranteed that penetrating humidity has no effect on the timber frame/second insulation layer.

ETICS are non load-bearing construction elements. They do not contribute directly to the stability of the timber frame building wall on which they are installed. The verification of the structural capacities of the wall and their suitability for the application of ETICS shall be in accordance with ETAG 007 (and its conversion into EAD), clause 5.1 using calculation methods (EN 1995-1-1, Eurocode 5 Part 1-1, etc) as well as verifications by testing (EN 380, EN 594, EN 595, EN 596, etc.) where the load bearing capacity is unable to calculate.

The ETICS can contribute to the durability of a timber frame building by providing enhanced protection from the effects of weathering.

ETICS are not intended to ensure the air tightness of the timber frame building structure. The timber frame building wall as such has therefore to be airtight to:

- a) reduce the thermal transmittance of the wall
- b) avoid interstitial condensation due to convection.

From the design point of view, ETICS are differentiated according to the methods of fixing:

**Bonded ETICS:**

1. Purely bonded ETICS.  
ETICS may be fully bonded (over the entire surface) or partially bonded in strips and/or dabs.
2. Bonded ETICS with supplementary mechanical fixings.

The load is totally distributed by the bonding layer. The mechanical fixings are used primarily to provide stability until the adhesive has reached the final mechanical strength and act as a temporary connection to avoid the risk of detachment.

**Mechanically fixed ETICS:**

3. Mechanically fixed ETICS with supplementary adhesive  
The load is totally distributed by the mechanical fixings. The adhesive is used primarily to ensure the flatness of the installed ETICS.
4. Purely mechanically fixed ETICS  
The ETICS are secured to the timber frame by mechanical fixings only.

**1.2.2 Working life/Durability**

The assessment methods included or referred to in this EAD have been written based on the manufacturer's request to take into account a working life of the ETICS on timber frames for the intended use of 25 years when installed in the works (provided that ETICS on timber frames is subject to appropriate installation). These provisions are based upon the current state of the art and the available knowledge and experience.

When assessing the product the intended use as foreseen by the manufacturer shall be taken into account. The real working life may be, in normal use conditions, considerably longer without major degradation affecting the basic requirements for works<sup>1</sup>.

The indications given as to the working life of the construction product cannot be interpreted as a guarantee neither given by the product manufacturer or his representative nor by EOTA when drafting this EAD nor by the Technical Assessment Body issuing an ETA based on this EAD, but are regarded only as a means for expressing the expected economically reasonable working life of the product.

---

<sup>1</sup> The real working life of a product incorporated in a specific works depends on the environmental conditions to which that works is subject, as well as on the particular conditions of the design, execution, use and maintenance of that works. Therefore, it cannot be excluded that in certain cases the real working life of the product may also be shorter than referred to above.

## 1.3 Specific terms used in this EAD

### 1.3.1 Substrate

See clause 1.2.1.

### 1.3.2 Adhesive and base coat

The adhesive, the base coat can include a range of binders from pure polymeric to pure cementitious. They are available in the following forms:

- Powder (dry mortar) blended at the factory that requires only mixing with a quantity of water specified by the manufacturer;
- Powder requiring addition of extra binder;
- Paste requiring addition of cement;
- Ready to use paste, supplied in workable consistency;
- Foam, taken directly from the bottle/can as an adhesive.

The adhesive is the component used for bonding the insulation product to the timber frame (external boards or to WW or WF insulation panels directly mounted on the timber frame).

### 1.3.3 Insulation product

It is a pre-fabricated product, with a high thermal resistance, which is intended to impart insulating properties to the substrate to which it is applied.

### 1.3.4 Rendering system

All the coats applied to the outer face of the insulation product together with the reinforcement.

- Reinforcement:  
Glass fibre mesh, metal lath or plastic mesh reinforcement (embedded) as well as fibres (dispersed) in the base coat to improve its mechanical strength.  
For glass fibre mesh, differentiation is made between:
  - Standard mesh: embedded in the base coat all over the area and tied positively at joints, mostly by overlapping,
  - Reinforced mesh: embedded in the base coat additionally to the standard mesh to improve the impact resistance, generally applied without overlapping.
- Render coating:  
The rendering is applied to the insulation product in one or several coats (application of a new coat on top of an existing dry coat).  
Installation can also be done in several layers (putting one layer on top of a fresh layer).  
Generally, multi-coat renders include the following:
  - Base coat: Coat applied directly onto the insulation product; the reinforcement is embedded into it and provides most of the mechanical properties of the rendering,
  - Key coat: Very thin coat which may be applied to the base coat and is intended to act as a preparation for the application of the finishing coat. It can also be possibly used for aesthetic reasons (for example in case of “dark” ribbed finishing coats).
  - Finishing coat: Coat which contributes to the protection against weathering and can provide a decorative finish; it is applied onto the base coat with or without a key coat.  
*Type of finishing coat: Where the only difference between two finishing coats is due to the size of the aggregates, they are designed as one type.*

- Decorative coat: Coat which generally contributes to the aesthetic finishing (to cover efflorescence ...) of the finishing coat and can also provide supplementary protection against weathering.

NOTE: In case where no more layers are applied on a base coat (the base coat functions as a finishing coat as well), the application of a finishing coat prescribed in test procedures shall be omitted.

### **1.3.5 Mechanical fixing devices**

Profiles, anchors, pins or any special fixing devices used to secure the ETICS to the substrate.

### **1.3.6 Ancillary materials**

Any supplementary component or product used in the ETICS, e.g. to form joints (mastics, corner strips, etc...) or to achieve continuity (mastic, joint-covers ...).



## 2. ESSENTIAL CHARACTERISTICS AND RELEVANT ASSESSMENT METHODS AND CRITERIA

### 2.1 Essential characteristics of the product

Table 1.1, 1.2, 1.3, 1.4 show how the performance of ETICS with renderings for the use on timber frame buildings and of its components are assessed in relation to the essential characteristics. The Manufacturer (or the Applicant) may select characteristics reviewed which he wishes to be assessed.

Table 1 Essential characteristics of the product and methods and criteria for assessing the performance of the product in relation to those essential characteristics

Tab. 1.1: ETICS

No	Essential characteristic	Assessment method	Type of expression of product performance (level, class, description)
<b>Basic Works Requirement 2: Safety in case of fire</b>			
1	Reaction to fire	See 2.2.1.1	Classification according to EC Delegated Regulation (EU) 2016/364.
<b>Basic Works Requirement 3: Hygiene, health and the environment</b>			
2	Water absorption	See 2.2.2.1	Level
3	Water tightness: Hygrothermal behaviour	See 2.2.2.2	Description
4	Water tightness: Freeze thaw behaviour	See 2.2.2.3	Description
5	Water tightness: Moisture content and gradient	See 2.2.2.4	Level
6	Water tightness: Water penetration	See 2.2.2.5	Level
7	Water vapour permeability	See 2.2.2.6	Level
<b>Basic Works Requirement 4: Safety and accessibility in use</b>			
8	Bond strength between: base coat and insulation product (mortar or paste)	See 2.2.3.1	Level
9	Bond strength between: adhesive and substrate (external board)	See 2.2.3.2	Level
10	Bond strength between: adhesive and insulation product	See 2.2.3.3	Level
11	Bond strength of foam adhesives	See 2.2.3.4	Level
12	Fixing strength (transverse displacement)	See 2.2.3.5	Level
13	Wind load resistance:	See 2.2.3.6	Level
14	- <i>pull-through tests of fixings</i>	See 2.2.3.6.1	Level
15	- <i>static foam block</i>	See 2.2.3.6.2	Level
16	- <i>dynamic wind uplift test</i>	See 2.2.3.6.3	Level
17	- <i>resistance to soft body impact</i>	See 2.2.3.6.4	Level
18	Impact resistance	See 2.2.3.19	Description
19	Bond strength after ageing	See 2.2.3.20 and 2.2.3.21	Level
<b>Basic Works Requirement 5: Protection against noise</b>			
20	Airborne sound insulation	See 2.2.4.1	Level
<b>Basic Works Requirement 6: Energy economy and heat retention</b>			
21	Thermal resistance and thermal transmittance	See 2.2.5.1	Level

Tab. 1.2: INSULATION PRODUCT

No	Essential characteristic	Assessment method	Type of expression of product performance (level, class, description)
<b>Basic Works Requirement 2: Safety in case of fire</b>			
1	Reaction to fire	See 2.2.1.3	Class in accordance with the hEN for the relevant insulation product
<b>Basic Works Requirement 3: Hygiene, health and the environment</b>			
2	Water absorption	See 2.2.2.7	Level
3	Water permeability	See 2.2.2.8	Level
<b>Basic Works Requirement 4: Safety and accessibility in use</b>			
4	Tensile test	See 2.2.3.7 and 2.2.3.8	Level
5	Shear strength and shear modulus of elasticity test	See 2.2.3.9	Level
6	Bending strength	See 2.2.3.10	Level
7	Dimensional stability of PF and ICB	See 2.2.3.11	Level
<b>Basic Works Requirement 5: Protection against noise</b>			
8	Dynamic Stiffness	See 2.2.4.2	Level
<b>Basic Works Requirement 6: Energy economy and heat retention</b>			
9	Thermal resistance	See 2.2.5.2	Level
10	Air flow resistance	See 2.2.5.3	Level

Tab. 1.3: MECHANICAL FIXINGS

No	Essential characteristic	Assessment method	Type of expression of product performance (level, class, description)
<b>Basic Works Requirement 2: Safety in case of fire</b>			
1	Reaction to fire	See 2.2.1.2	MECHANICAL FIXINGS: evaluated according to EOTA TR 021
<b>Basic Works Requirement 4: Safety and accessibility in use</b>			
2	Pull-out strength of fixings from profiles	See 2.2.3.13	Level
3	Pull-out strength of mechanical fixings (anchors, staples, screws etc)	See 2.2.3.14	Level
4	Protection against corrosion	See 2.2.3.22	Level

Tab. 1.4: OTHER COMPONENTS

No	Essential characteristic	Assessment method	Type of expression of product performance (level, class, description)
<b>Basic Works Requirement 4: Safety and accessibility in use</b>			
1	BASE COAT performances	See 2.2.3.15 and 2.2.3.16	Level
2	FOAM ADHESIVE Shear strength and shear modulus of foam adhesives	See.2.2.3.17	Level
3	FOAM ADHESIVE Post expansion behaviour	See 2.2.3.18	Level
4	RENDERING SYSTEM Tensile strength	See 2.2.3.12	Level
5	REINFORCEMENT Tearing strength and elongation	See 2.2.3.23 2.2.3.24 2.2.3.25	Level

## 2.2 Methods and criteria for assessing the performance of the product in relation to essential characteristics of the product

### 2.2.1 Safety in case of fire

General Note: the evaluation of the behaviour in fire of the assembled system will be subject to further national provisions in some Member States.

#### 2.2.1.1 Reaction to fire of the ETICS

The ETICS shall be tested, using the test method(s) relevant for the corresponding reaction to fire class, in order to be classified according to EC Delegated Regulation (EU) 2016/364.

The determination of the worst case(s) as well as the mounting and fixing provisions that are considered to be appropriate for the testing and are representative of the intended end use application are specified in Annex A.

#### 2.2.1.2 Reaction to fire of mechanical fixings

Evaluated according to EOTA TR 021.

#### 2.2.1.3 Reaction to fire of insulation products

Evaluated according to appropriate harmonized technical specification for the relevant insulation product and taking into account of the specific substrates (wood based panels, plasterboards, gypsum bonded boards, cement bonded boards...) used in timber frame buildings where necessary. (Selection of the suitable standard substrate according EN 13238).

## 2.2.2 Hygiene, health and the environment of ETICS and its components

### 2.2.2.1 Water absorption of the ETICS (capillarity test)

These tests have 3 purposes, to determine:

- the water absorption
- which finishing coats should be applied on the rig to be subjected to hygrothermal testing
- whether the freeze-thaw testing is suggested.

#### *Preparation of the samples*

Samples are prepared, each by taking a piece of the specified insulation product, surface area to be at least 200 mm x 200 mm, and applying, in accordance with the Manufacturer's instructions, e.g. thickness, mass per unit area and method of application, both:

- the reinforced base coat alone
- and
- the configurations of complete rendering systems proposed by the Manufacturer, i.e. reinforced base coat covered with each type of finishing coat and (associating or not) key coat and/or decorative coat. If the application of the key coat and/or the decorative coat is optional, at least configurations without them should be tested.

Within a type of finishing coat, the test shall be carried out with at least the thickest layer (generally higher particle size grading with floated finishing aspect).

Three samples are prepared for each configuration. Quantities and/or thicknesses applied shall be recorded.

The prepared samples are conditioned for at least 7 days at  $(23 \pm 2)^\circ\text{C}$  and  $(50 \pm 5) \% \text{RH}$ .

The edges of the samples, including the insulation product, are sealed against water, to ensure that during subsequent testing, only the face of the reinforced base coat or the rendering system is subject to water absorption.

They are then subject to a series of 3 cycles comprising the following phases:

- 24 h immersion in a water bath (tap water) at  $(23 \pm 2)^\circ\text{C}$ . The samples are immersed rendered face downwards, to a depth of 2 to 10 mm, the depth of immersion dependent upon surface roughness. To achieve complete wetting of rough surfaces, the samples shall be tilted as they are introduced into the water. The depth of immersion can be regulated in the water tank by means of a height-adjustable slat.
- 24 h drying at  $(50 \pm 5)^\circ\text{C}$ .

If interruptions are necessary, e.g. at week-ends or holidays, the samples are stored at  $(23 \pm 2)^\circ\text{C}$  and  $(50 \pm 5) \% \text{RH}$  after the drying at  $(50 \pm 5)^\circ\text{C}$ .

After the cycles, the samples are stored for at least 24 h at  $(23 \pm 2)^\circ\text{C}$  and  $(50 \pm 5) \% \text{RH}$ .

#### *Capillarity test procedure<sup>2</sup>:*

To start the capillarity test the samples are again immersed in a water bath as described above.

The samples are weighed after 3 minutes immersion in the bath (reference mass) and then after 1 hour and 24 hours. Prior to the second and subsequent weighing, water adhering to the surface of the sample is removed with a damp sponge cloth.

If the ETICS is applied down to the ground and is therefore exposed to rising damp, the Assessment Body may need to develop additional tests in an appropriate way subject to consensus within EOTA.

#### *Analysis of results and assessment:*

Calculation is undertaken to determine the mean water absorption of the three samples per square metre after 1 and 24 hours. The outcome of these results will determine the finishing coats to be applied on the rig for the Hygrothermal behaviour and the Freeze/Thaw test. The freeze/thaw test is suggested if the water absorption of either the reinforced base coat or of the rendering coating is equal to or more than  $0.5 \text{ kg/m}^2$  after 24 hours.

---

<sup>2</sup> In order to provide information about the stabilisation, the water absorption measured can be plotted on a chart as a function of  $\sqrt{t}$

### 2.2.2.2 Water tightness of the ETICS: Hygrothermal Behaviour

Based on the outcome of the water absorption test, Annex B gives recommendations of the product to be tested (e.g. the number of finishing coats). Some samples are prepared at the same time as the rig in order to evaluate the following characteristics after heat/rain and heat/cold cycles (for sample size and number, see relevant test method clauses):

- Bond strength between the base coat and insulation product (only if the low part of the rig does not only consist of the reinforced base coat alone, i.e. ETICS with only one finishing coat)
- Tensile strength and elongation at break (for products with an application thickness up to 5 mm).

In the case of reinforced base coat with a thickness greater than 5 mm, complementary samples shall also be prepared to perform the test on the hardened product.

#### Principles related to the preparation of the rig:

- As a general rule, only one reinforced base coat and at the very most four finishing coats (vertical divisions) can be applied per rig.
- If several adhesives are proposed for the ETICS, only one shall be tested on the rig.
- If more than 4 finishing coats are proposed for the ETICS, the maximum number of coats, representative of the different types proposed, shall be tested on rig(s). Furthermore, if the water absorption of the reinforced base coat after 24 h is equal to or more than 0.5 kg/m<sup>2</sup>, each type of finishing coat containing a pure polymeric binder (non cementitious) shall be submitted to hygrothermal cycles on rig(s). Any finishing coats not tested on the rig shall be examined according to 2.2.3.20.
- If different finishing coats can be used in the ETICS, the lower part of the test piece (1.5 x insulating panel height) consists of the reinforced base coat only without any finishing coat.
- If several ETICS differ only in the method of fixing (bonded or mechanically fixed) of the insulation product, the test is only carried out on the ETICS applied with adhesive at the edge of the rig and with mechanical fixings devices in the centre.
- If several ETICS differ only in the type of insulation product, two insulation products can be applied to the rig. The insulation products are divided vertically at the centre of each rig.
- The ETICS is applied, in accordance with the manufacturer's instructions, alternatively:
  - on a timber frame coupled with a board chosen among the ones falling within the description given in 1.1 of this EAD and among the alternative boards recommended by the manufacturer;
  - on a simple timber frame in case of ETICS using WW and WF insulation products;
  - on a sufficiently stabilised masonry or concrete substrate; also in this case a board can be inserted between the ETICS and the substrate; it shall fall within the description given in 1.1 of this EAD and among the alternative boards recommended by the Manufacturer.
- The ETICS shall also be applied to the lateral faces with a uniform maximum thickness of insulation product of 20 mm. If the insulation product is not available in this thickness (Mineral wool Lamella for example), the lateral faces can be covered with a thickness of 20 mm expanded polystyrene.
- Insulation product requiring stabilisation (prescribed delay between production and sale) shall be no older than 15 days beyond the minimum specified period.
- The dimensions of the rig shall be:
  - surface ≥ 6 m<sup>2</sup>
  - width ≥ 2.50 m
  - height ≥ 2.00 m.

A rectangular opening (consisting of the absence of the ETICS on the substrate at this area) is included at the corner of the rig, 0.40 m wide by 0.60 m high, positioned 0.40 m from the edges.

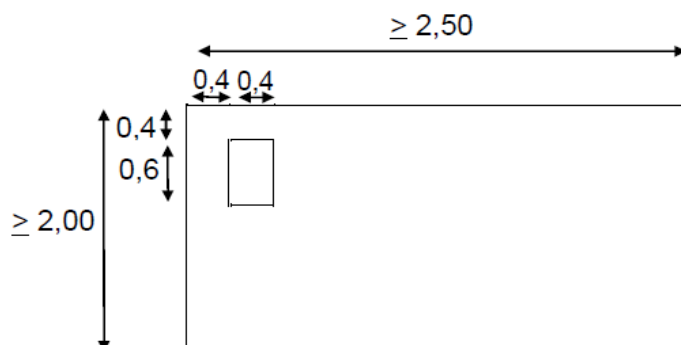

Fig. 2: Dimensions of the rig (in metres) for the hygrothermal cycles

Remark: if two insulation products are foreseen to be applied to the rig, two symmetrical openings shall be included at both of the upper corners of the rig. Furthermore, two openings shall be applied in order to affect all tested finishing coats.

Special methods for reinforcing corners of the opening are applied, if necessary.  
Installation of the window sill and other ancillary materials is under responsibility of the Manufacturer.

#### Preparation of the rig:

The rig preparation shall be made by the Manufacturer. It shall be supervised by the laboratory in charge of the test regarding:

- in case of insulation product requiring stabilisation (prescribed delay between production and sale), verification that it is not older than 15 days beyond the minimum specified period.
- checking of the respect of manufacturer prescriptions: all stages shall be in accordance with the Technical File of the Manufacturer
- registering of all the stages of the installation:
  - the date and time of the various stages
  - temperature and % Relative Humidity during the installation (every day – at least at the beginning)
  - name and production lot of the components
  - way of fixing the insulation product
  - Figure describing the rig (place of the fixings and of the joints between the panels, ...)
  - way of renders preparation (tool, % of mixing, possible pause time before application,...) as well as their way of application (hand tool, machines, number of layers,...)
  - quantities and/or thickness of renders applied per square metre
  - drying period between each layer
  - use and position of accessories
  - any other information.

#### Conditioning of the rig:

The ETICS is cured indoors for a minimum of 4 weeks. During the curing time the ambient temperature shall be between 10°C and 25°C. The relative humidity shall not be less than 50%. To ensure that these conditions are met, records shall be made at regular intervals.

To prevent the ETICS from drying out too rapidly, the Manufacturer may require the render to be wetted once per week by spraying for approximately 5 minutes. This wetting shall start at a time according to the prescriptions of the Manufacturer.

During the curing time any deformations of the ETICS, i.e. blistering, cracking, are recorded. For a reinforced base coat with a thickness up to 5 mm, some samples are prepared according to 2.2.3.16 and placed in the opening of the rig.

### Hygrothermal cycles

The test apparatus is positioned against the front face of the rig, 0.10 to 0.30 m from the edges.

The specified temperatures during the cycles are measured at the surface of the rig. The regulation shall be obtained by adjustment of the air temperature.

#### *Heat - rain cycles:*

The rig is subjected to a series of 80 cycles, comprising the following phases:

- 1- heating to 70°C (rise for 1 hour) and maintaining at  $(70 \pm 5)^\circ\text{C}$  and 10 to 30% RH for 2 hours (total of 3 hours),
- 2- spraying for 1 hour (water temperature  $(+ 15 \pm 5)^\circ\text{C}$ , amount of water 1 l/m<sup>2</sup> min),
- 3- leave for 2 hours (drainage).

#### *Heat-cold cycles:*

After at least 48 hours of subsequent conditioning at temperatures between 10 and 25°C and a minimum relative humidity of 50 %, the same test rig is exposed to 5 heat/cold cycles of 24 hours comprising the following phases:

- 1- exposure to  $(50 \pm 5)^\circ\text{C}$  (rise for 1 hour) and maximum 30% RH for 7 hours (total of 8 hours),
- 2- exposure to  $(- 20 \pm 5)^\circ\text{C}$  (fall for 2 hours) for 14 hours (total of 16 hours).

#### Observations during the test:

At periods of every four cycles during the heat/rain cycles and at every cycle during the heat/cold cycles, observations relating to a change in characteristics or performance (blistering, detachment, crazing, loss of adhesion, formation of cracks, etc ...) of the entire ETICS and of the part of the rig consisting of only the reinforced base coat are recorded as follows:

- the surface finish of the ETICS is examined to establish whether any cracking has occurred; the dimensions and position of any cracks shall be measured and recorded,
- the surface shall also be checked for any blistering or peeling and the location and extent shall again be recorded,
- the sills and profiles shall be checked for any damage/degradation together with any associated cracking of the finish. Again, the location and extent shall be recorded.

Following the completion of the test, a further investigation is conducted involving removal of sections containing cracks to observe any water penetration within the ETICS.

For the assessment of Hygrothermal Behaviour either for the reinforced base coat (if a part without finishing coat is required) or for the ETICS, the following defects can be stated:

- blistering or peeling of any finishing coat
- failure or cracking associated with joints between insulation product boards or profiles fitted with ETICS
- detachment of the render coat
- cracking allowing water penetration to the insulating layer (normally  $\leq 0.2$  mm).

#### After the heat-rain and heat-cold cycles:

Bond strength tests according to 2.2.3.1, 2.2.3.20 and impact resistance test according to 2.2.3.19 shall be performed, after at least 7 days drying.

### 2.2.2.3 Water tightness of the ETICS: Freeze-thaw behaviour

The verification of freeze-thaw should be carried out as determined by the analysis of the capillarity test, i.e. should be conducted except if the water absorption after 24 hours of both the reinforced base coat and the rendering system determined with each type of finishing coat is less than 0.5 kg/m<sup>2</sup>.

The test shall be carried out on three samples 500 mm x 500 mm consisting of a piece of the specified insulation product covered by:

- reinforced base coat without finishing coat if its water absorption is equal to or higher than 0.5 kg/m<sup>2</sup> after 24 hours,
- all the configurations of rendering systems proposed by the Manufacturer (i.e. reinforced base coat covered with each type of finishing coat and (associating or not) key coat and/or decorative coat which lead to a water absorption equal to or higher than 0.5 kg/m<sup>2</sup> after 24 hours. If the application of the key coat and/or the decorative coat is optional, at least configurations without them shall be tested). These samples

are prepared according to the Manufacturer's instructions and then stored for at least 28 days at  $(23 \pm 2)^{\circ}\text{C}$  and  $(50 \pm 5) \% \text{RH}$ .

### Cycles

The samples are then subjected to a series of 30 cycles (one cycle lasts for 24 hours) comprising:

- Exposure to water for 8 hours at initial temperature of  $(23 \pm 2)^{\circ}\text{C}$  by immersion of the samples, render face downwards, in a water bath, by the method described in 2.2.2.1, Capillarity test,
- Freezing to  $(- 20 \pm 2)^{\circ}\text{C}$  (fall for 5 hours at the sample surface and for 2 hours in the conditioned air) for respectively 11 and 14 hours (total of 16 hours).

If the test is interrupted, because the samples are handled manually and there are stops during weekends or holidays, the samples shall always be maintained immersed in water between the cycles.

*Remark:* The specified temperatures are measured at the surface of the samples. The regulation is obtained by conditioned air.

The assessment of Freeze-thaw behaviour is carried out as follows: at the end of the test, observations relating to a change in characteristics of the surface or to the behaviour of the entire ETICS are recorded. Any distortion at the edges of the samples shall also be reported.

After the test, a bond strength test shall be performed on each sample submitted to freeze-thaw cycles.

### 2.2.2.4 Water tightness: Moisture content and moisture gradient of the wooden substructure. Small scale test (for ETICS using MW, WW, WF or ICB)

The small scale test method of verification (for ETICS using MW, WW, WF or ICB) is used. Due to the fact that the insulation product influences strongly the diffusion of water vapour the following test is not necessary for EPS, XPS, PU, PF.

The ETICS is applied to a timber frame element with and/or without external board in accordance with the manufacturers instructions. In the case that the ETA shall cover several boards the test has to be done with the most sensitive to deformation, using the following ranking list (from worse to better):

1. Wood-based panels (organic bonding)
2. Cement bonded particle boards
3. Fibre-cement panels (cement bonded fibre boards)
4. Gypsum bonded particle boards
5. Gypsum plaster boards
6. Fibre-gypsum panels (gypsum bonded fibre boards).

### Preparation of the test sample

- As a general rule the most water vapour permeable finishing coat shall be tested.
- The rendering system shall be applied on two insulation boards (thinnest thickness) which are fixed with or without an external board to a wooden frame made of elements 16 x 6 cm of the following dimensions:
  - width  $\geq 0.60 \text{ m}$
  - height  $\geq 0.60 \text{ m}$
  - surface  $\geq 0.36 \text{ m}^2$
- The temperature and the humidity of the test laboratory is  $23 \pm 2^{\circ}\text{C}$  &  $50 \pm 5 \% \text{RH}$ .
- The horizontal joint between the rendered insulation boards shall be sealed according to the recommendations of the manufacturer.
- In the wooden frame a wooden cross for the humidity measurements shall be fixed made of the same elements as the frame.
- The edges of the sample are sealed and the open spaces between the wooden frame and wooden cross filled with mineral wool (MW - EN 13162 – Ti – DS(i) – Mui). The backside of the specimen is closed by a PMMA board (EN ISO 7823) simulating the water vapour barrier.



Method of operation

The rendered surface of the test specimen is positioned airtight against a climatic chamber. The determination of the humidity and the humidity gradient of the wooden substructure is done with 10 electronic humidity sensing elements (F1- F10) at the following positions:

- F1, F3 at a distance of 15cm from the PMMA board and a height of 20 cm
- F2, F4 at a distance of 15cm from the PMMA board and a height of 40 cm
- F5, F7 at a distance of 5 cm from the PMMA board and a height of 20 cm
- F6, F8 at a distance of 5 cm from the PMMA board and a height of 40 cm
- F9 at a distance of 15 cm from the PMMA board and a height of 20 cm
- F10 at a distance of 15 cm from the PMMA board and a height of 40 cm.

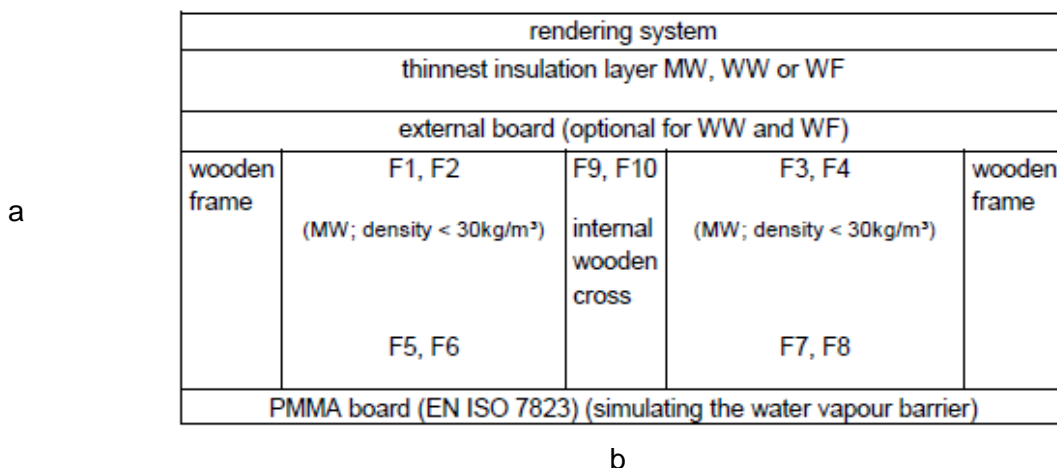

Fig. 3: view from above on the specimen, where a: 16 cm and b = 60 cm

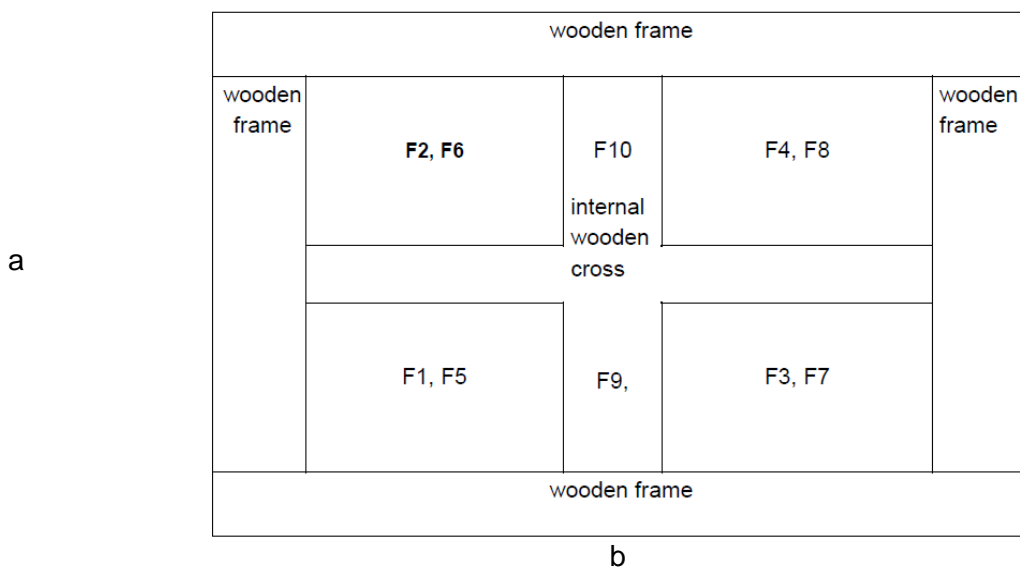

Fig. 4: view from back of the specimen, where a: 16 cm and b = 60 cm

The determination of the humidity of the external board (if existing in the ETICS) has to be done before and after the following climatic cycles by the gravimetric method (EN 322).

Climatic cycles

The climatic cycles are divided into two periods.

1. period: 50 summer cycles
  - maintaining at  $10 \pm 5^\circ\text{C}$  and  $60 \pm 5\% \text{ RH}$  for 7 hours ,
  - heating to  $60 \pm 5^\circ\text{C}$  and  $10 \pm 5\% \text{ RH}$  (rise for 1 hour) and maintaining at  $60 \pm 5^\circ\text{C}$  and  $10 \pm 5\% \text{ RH}$  for 2 hours,

- maintaining at  $60 \pm 5^\circ\text{C}$  and  $95 \pm 5\%$  RH for 1 hour,
  - cooling to  $10 \pm 5^\circ\text{C}$  and  $60 \pm 5\%$  RH (drop for 1 hour)
  - maintaining at  $10 \pm 5^\circ\text{C}$  and  $60 \pm 5\%$  RH for 4 hours (total of 16 hours),
2. period: 20 winter cycles
- maintaining at  $-20 \pm 5^\circ\text{C}$  for 7 hours,
  - heating to  $30 \pm 5^\circ\text{C}$  and  $50 \pm 5\%$  RH (rise for 2 hour) and maintaining at  $30 \pm 5^\circ\text{C}$  and  $50 \pm 5\%$  RH for 2 hours,
  - cooling to  $-20 \pm 5^\circ\text{C}$  (drop for 2 hours)
  - maintaining at  $-20 \pm 5^\circ\text{C}$  for 3 hours (total of 16 hours).

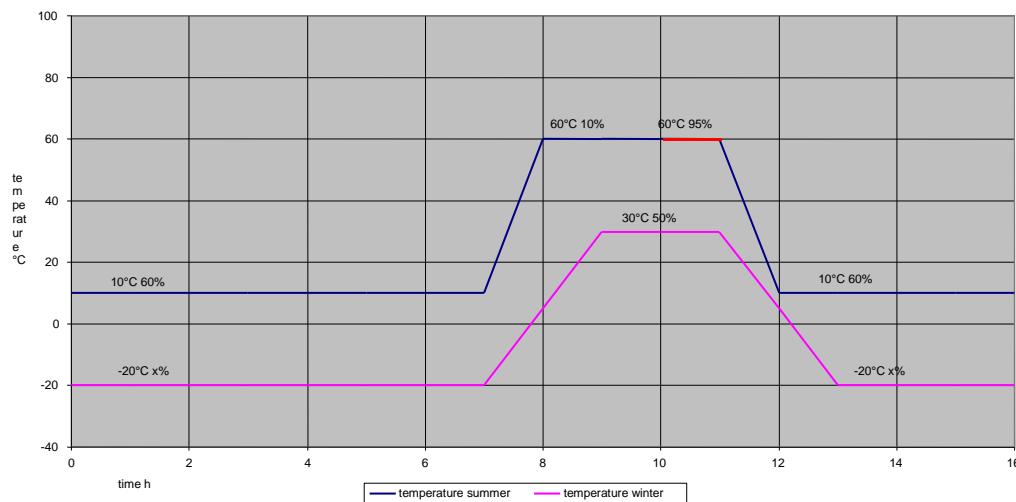

Fig. 5: Climatic cycles

For the assessment of moisture content and moisture gradient of ETICS using MW, WW, WF or ICB, the percentage in mass has to be recorded. The following observations after the test relating to a performance change of the entire ETICS have to be recorded:

- the surface finish of the ETICS is examined whether any cracking has occurred; the dimensions and position of any cracks should be measured and recorded,
- the surface should be checked for any blistering, peeling detachment or loss of adhesion; the location and extent should be recorded,
- the absolute single values measured by each humidity sensing element F1 to F10 and the gradient should be recorded.

*Results of large scale test (modified EOTA rig, UEAtc method, WKI method) can be accepted in the assessment procedure if sufficient proof is provided about the equivalence of the test results.*

#### 2.2.2.5 Water tightness: Water penetration of the ETICS

For the verification of water penetration, tests should be conducted on a test sample that incorporates an opening detail and has been installed onto a suitable frame. The sample should undergo hydrothermal ageing generally in accordance with 2.2.2.2 and a series of freeze-thaw cycles<sup>3</sup>.

<sup>3</sup> Freeze/thaw cycles on the rig: five samples are prepared (see relevant test method for sample size and number); sealed joints shall be sufficiently stabilised prior to test (normally 28 days for cement seals).

Method of operation: the test apparatus is positioned against the front face of the rig at approximately 0.10 to 0.30 m from the edges. Five samples are inside the test apparatus. The specified temperatures during the cycles are measured at the surface of the rig.

##### Cycles

The rig is then subjected to a series of 30 cycles comprising:

- Exposure to water for 8 hours at  $(+ 23 \pm 2)^\circ\text{C}$
- Freezing to  $(- 20 \pm 2)^\circ\text{C}$  (fall for 2 hours) for 14 hours (total of 16 hours).

The sample should incorporate a number of horizontal and vertical joints.

The simulated driven rain test should be conducted generally in accordance with EN 12865. The pressure difference witnessed during the test should be compared to Table 2a below. Water penetration during the test should be recorded.

Pressure range (Pa)	Equivalent exposure zone <sup>4</sup>
> 931 - <1032	Sheltered
1032 - <1249	Moderate
1249 - 1365	Severe

Table 2a – Equivalent exposure zone

For the assessment of water penetration of the ETICS, the overall rating has to be measured as follows:

Overall rating =  $D_{r\ test} \cdot D_f \cdot I_f \cdot M_f$  (for factors  $D_{r\ test}$ ,  $D_f$ ,  $I_f$  and  $M_f$  see Annex C)

and put in relation to the following Table 2b:

Overall rating	Suitability
> 0 to ≤ 10	Suitable for use in the situation that the test method indicates is ok
> 10 to ≤ 20	Suitable for use in the exposure zone indicated by the test method with increased maintenance and inspection
> 20 to ≤ 40	Suitable for use in less exposed zones than those indicated by the test method with increased maintenance and inspection <sup>5</sup>
> 40 to ≤ 100	Suitable for use in sheltered zones with increased maintenance and inspection
> 100	System should be redesigned to incorporate factors that reduce the overall rating and reassessed

Table 2b – Overall rating

#### 2.2.2.6 Water vapour permeability of the ETICS (resistance to water vapour diffusion)

The verification of water vapour permeability takes place as follows: the test shall be performed on all the configurations of rendering systems proposed by the Manufacturer, i.e. reinforced base coat covered with each type of finishing coat and (associating or not) key coat and/or decorative coat. If the application of the key coat and/or the decorative coat is optional, configurations with and without shall be tested. Within a type, the test shall be carried out with the thickest continuous layer (generally higher particles size grading with floated finishing aspect).

The samples are prepared by applying the rendering to the insulation product in accordance with the Manufacturer's instructions and conditioned for at least 28 days at  $(23 \pm 2)^\circ\text{C}$  and  $(50 \pm 5)\%$  RH. Five test samples of at least 5000 mm<sup>2</sup> are then obtained by separating the rendering system from the insulation product.

The test is carried out on the rendering system in accordance with EN ISO 7783. The test shall be carried out in an enclosure at  $(23 \pm 2)^\circ\text{C}$  and  $(50 \pm 5)\%$  RH. The dish contains a saturated solution of ammonium dihydrogen phosphate ( $\text{NH}_4\text{H}_2\text{PO}_4$ ). The results are expressed in metres (of air) and the resistance to water vapour diffusion is determined as the mean value and rounded to 1/10 m (one decimal).

The assessment of water vapour permeability takes place as follows: the value shall be stated in the ETA, with precision on the corresponding tested rendering system(s), in order to enable the designer to evaluate the risk of interstitial condensation.

<sup>4</sup> The systems should not be used in zones that have more than severe exposure, i.e. very severe.

<sup>5</sup> For example, this rating could result in a change from Severe to Moderate exposure zones

**2.2.2.7 Water absorption of insulation product**

Only if no test method is defined in the appropriate harmonized technical specification for the relevant insulation product and if no related values accompany the CE marking of the product, the test shall be performed in accordance with EN 1609.

The value expressed in kg/m<sup>2</sup> after 24 hours shall be stated in the ETA.

**2.2.2.8 Water permeability of insulation product**

Only if no test method is defined in the appropriate harmonized technical specification for the relevant insulation product, and if no related values accompany the CE marking of the product, the test shall be performed in accordance with EN 12086.

The μ-value shall be stated in the ETA.

**2.2.3 Safety in use**

Whichever type of fixing used, the bond strength between the base coat and the insulation product shall be tested according to the following clauses. In particular, depending on the fixing type, the stability of the ETICS on the substrate is assessed according to the tests specified in Table 3.

For purely mechanically fixed WW/WF ETICS on the timber frame the column “profiles” and line insulation products type “others” apply.

		Fixing type			
		Mechanically fixed <sup>2), 5)</sup>			
		Bonded <sup>1)</sup> Fully or partially	Anchors fixed through the reinforcement	Anchors fixed through the insulation product only	Profiles
Insulation product type	Cellular plastic EPS EN 13163 XPS EN 13164 PU EN 13165 PF EN 13166 or mineral wool MW EN 13162	Bond strength between base coat and insulation product according to 2.2.3.1			
		Bond strength 2.2.3.2 and 2.2.3.3 or 2.2.3.4	Static foam block test 2.2.3.6.2 and Displacement test <sup>4)</sup> 2.2.3.5.1	Pull-through test 2.2.3.6.1 and/or <sup>3)</sup> Static foam block test 2.2.3.6.2 and Displacement test <sup>4)</sup> 2.2.3.5.1	Static foam block test 2.2.3.6.2 and Displacement test <sup>4)</sup> 2.2.3.5.1
	WW EN 13168 WF EN 13171 ICB EN 13170 Other	Bond strength between base coat and insulation product according to 2.2.3.1			
		Bond strength 2.2.3.2 and 2.2.3.3 or 2.2.3.4 and Dynamic wind uplift test 2.2.3.6.3	Dynamic wind uplift test 2.2.3.6.3 and Displacement test <sup>4)</sup> 2.2.3.5.1	Dynamic wind uplift test 2.2.3.6.3 and Displacement test <sup>4)</sup> 2.2.3.5.1	Dynamic wind uplift test 2.2.3.6.3 and Displacement test <sup>4)</sup> 2.2.3.5.1

Table 3: Tests for verifying the safety in use

- 1) The tests on bonded ETICS with supplementary mechanical fixing devices shall be conducted without the fixings.
- 2) The tests on mechanically fixed ETICS with supplementary adhesive shall be conducted without the adhesive. If the bonded area is less than 20 %, the ETICS is considered to be purely mechanically fixed.
- 3) Decision on which test to perform is based on Figure 9.
- 4) Only for ETICS not fulfilling the criteria in 2.2.3.5.
- 5) If the mechanical fixing is not intended to transfer shear load of the ETICS, foams as supplementary adhesives shall be tested according to 2.2.3.2 and 2.2.3.2 or 2.2.3.3.

### 2.2.3.1 Bond strength between base coat (mortar- or paste) and insulation product

The following tests are used for the verification of bond strength between base coat (mortar- or paste) and insulation product:

- on a panel of the insulation product faced with the base coat applied in accordance with the Manufacturer's instructions and dried for at least 28 days under the same conditions as the rig;
- on samples taken from the rig after hygrothermal cycles (heat-rain and heat-cold cycles) or on separated samples placed in the climatic chamber (only if the low part of the rig does not only consist of the reinforced base coat alone, i.e. without any finishing coat), the test being always performed after at least 7 days drying;
- if freeze-thaw cycles are necessary, on the samples of reinforced base coat alone after the freeze-thaw cycles and dried for at least 7 days after the end of the cycles.

Five squares with appropriate sample size are cut through the base coat according to Figure 6 using an angle grinder. The dimensions should be the same as the samples for testing the tensile strength perpendicular to the faces according to the respective technical specification of the insulation product. Square metal plates of appropriate size are affixed to these areas with a suitable adhesive.

The pull-off test is performed at a tensioning speed of  $10 \pm 1$  mm/minute.

The mean failure resistance is based on the results of five tests.

The individual and mean values are recorded and the results are expressed in  $\text{N/mm}^2$  (MPa).

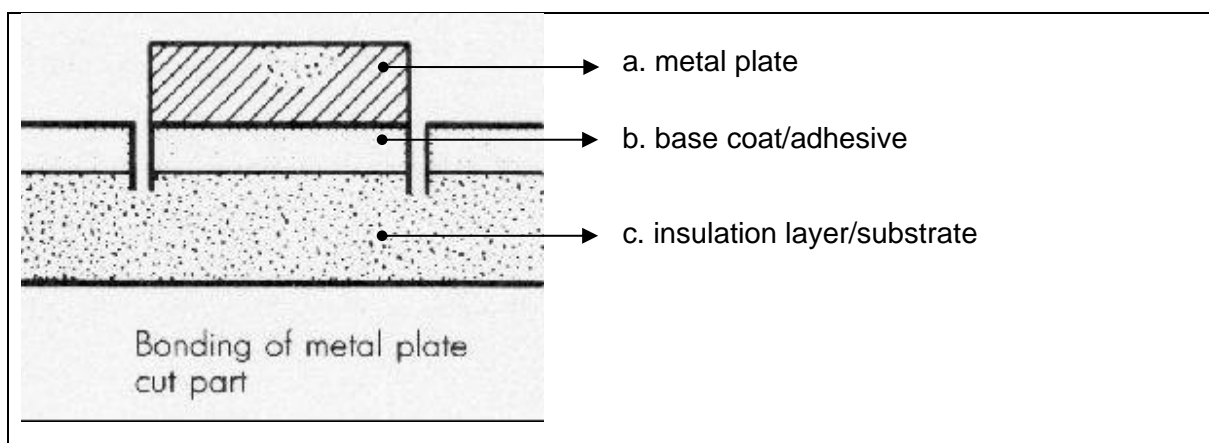

Fig. 6: Pull-off test

### 2.2.3.2 Bond strength test between adhesive (mortar or paste) and substrate (external boards)

The test shall be carried out for bonded ETICS only.

If the ETA shall cover several boards the tests have to be performed on at least one panel of each product family (wood based panel, plasterboard, cement bonded particle board, etc.), which has to be conditioned at  $(23 \pm 2)^\circ\text{C}$  and  $(50 \pm 5)\%$  RH for min. 48 h prior to application of the adhesive.

If the ETICS envisages external boards similar to the one quoted in 1.1, the test has to be performed with each 'similar product'.

The adhesive is spread on the substrate. Normally, the thickness is from 3 to 5 mm, unless another value is agreed between the manufacturer and Assessment Body. After allowing the adhesive to cure at  $(23 \pm 2)^{\circ}\text{C}$  and  $(50 \pm 5) \% \text{RH}$  for at least 28 days, 15 squares 15 to 25 cm<sup>2</sup> in area are cut through the adhesive according to Figure 6. Metal plates of appropriate size are bonded to the squares using a suitable adhesive.

The pull-off test is performed at a tensioning speed of  $10 \pm 1$  mm/minute on the following samples (5 samples each):

- without supplementary conditioning (dry condition),
- after conditioning at  $(23 \pm 2)^{\circ}\text{C}$  and  $(95 \pm 5) \% \text{RH}$  for 7 days (humid conditions),
- after conditioning at  $(23 \pm 2)^{\circ}\text{C}$  and  $(95 \pm 5) \% \text{RH}$  for 7 days and 7 days drying at  $(23 \pm 2)^{\circ}\text{C}$  and  $(50 \pm 5) \% \text{RH}$ .

Additionally the adhesive shall be tested in wet conditions:

- after immersion of the adhesive in water for 2 days and 2 h drying at  $(23 \pm 2)^{\circ}\text{C}$  and  $(50 \pm 5) \% \text{RH}$ , on a concrete slab.

The mean failure resistance is based on the results of five tests.

The individual and mean values are recorded and the results expressed in N/mm<sup>2</sup> (MPa).

The alternative external boards have to be specified in the ETA.

### 2.2.3.3 Bond strength test between adhesive (mortar or paste) and insulation product

The test shall be carried out for bonded ETICS only.

The test is performed on the insulation product specified for the ETICS.

The adhesive is spread on the insulation product. Normally, the thickness is from 3 to 5 mm, unless another value is agreed between the manufacturer and Assessment Body. After allowing the adhesive to cure at  $(23 \pm 2)^{\circ}\text{C}$  and  $(50 \pm 5) \% \text{RH}$  for at least 28 days, 15 squares, with appropriate sample size are cut through the adhesive according to Figure 6 using an angle grinder. The dimensions should be the same as the samples for testing the tensile strength perpendicular to the faces according to the respective technical specification of the insulation product. Square metal plates of appropriate size are affixed to these areas with a suitable adhesive.

The pull-off test is performed with the same conditions as described in 2.2.3.2 (5 samples each):

- without supplementary conditioning (dry condition),
- after immersion of the adhesive in water for 2 days and 2 h drying at  $(23 \pm 2)^{\circ}\text{C}$  and  $(50 \pm 5) \% \text{RH}$ ,
- after immersion of the adhesive in water for 2 days and at least 7 days drying at  $(23 \pm 2)^{\circ}\text{C}$  and  $(50 \pm 5) \% \text{RH}$ .

The mean failure resistance is based on the results of five tests.

The individual and mean values are recorded and the results expressed in N/mm<sup>2</sup> (MPa).

The tested thickness of adhesive has to be introduced in Evaluation Report.

### 2.2.3.4 Bond strength of foam adhesives

The bond strength tests shall be performed according to EOTA Technical Report 046 - "Test methods for foam adhesives for ETICS".

### 2.2.3.5 Fixing strength (transverse displacement)

The purpose of the test is to assess the longitudinal displacement of the ETICS at the edges of the wall.

The displacement test is not required for ETICS fulfilling one or more of the following criteria:

- Mechanically fixed ETICS with supplementary adhesive, where the bonded area exceeds 20 %
- $E \times d < 50\,000$  N/mm (E: modulus of elasticity of the base coat without mesh; d: thickness of the base coat)

- ETICS intended only for continuous areas of rendering with a width or height less than 10 m
- minimum insulation thickness used in ETICS is more than 120 mm
- ETICS having a base coat where after the Render Strip Tensile Test (2.2.3.12) at 2 % render strain value, only cracks with a width of less than or equal to 0.2 mm are observed
- ETICS using fixing devices of which the fatigue bonding strength has been verified by testing.

#### Displacement test

##### Preparation of samples:

The test is performed with the thinnest insulation product envisaged to be covered by the ETA. A reinforced concrete slab measuring 1.0 m x 2.0 m with a thickness of 100 mm is prepared with a smooth surface. A small layer of sand is placed on top of the slab to allow the insulation panel to slide. Three (2 + 2/2) insulating panels are applied to the concrete slab with tight butt joints as illustrated in Figure 7. The ETICS shall be fixed with the minimum number of mechanical fixing devices according to the Manufacturer's instructions. The reinforced base coat is then applied to the insulation product according to the manufacturer's specification. The reinforcement shall protrude on all sides of the slab by about 300 mm. The rendering shall be cured for at least 28 days at  $(23 \pm 2)^\circ\text{C}$  and  $(50 \pm 5) \% \text{RH}$ . Before testing, a foam block is bonded to the cured rendering; the protruding ends of the reinforcement are then fixed to the clamping jaws over their full length.

##### Execution of test:

A simulated wind suction load of 2000 Pa is applied to the ETICS via the foam block and glued plywood or other rigid panel. Simultaneously, a normal tensile load is applied to the rendering of the ETICS via the clamped-in reinforcement. At a tensioning speed of 1 mm/min the resulting displacement of the ETICS relative to the concrete slab and the corresponding load is measured. Preferably, the concrete slab is placed on top and the ETICS is applied under the slab.

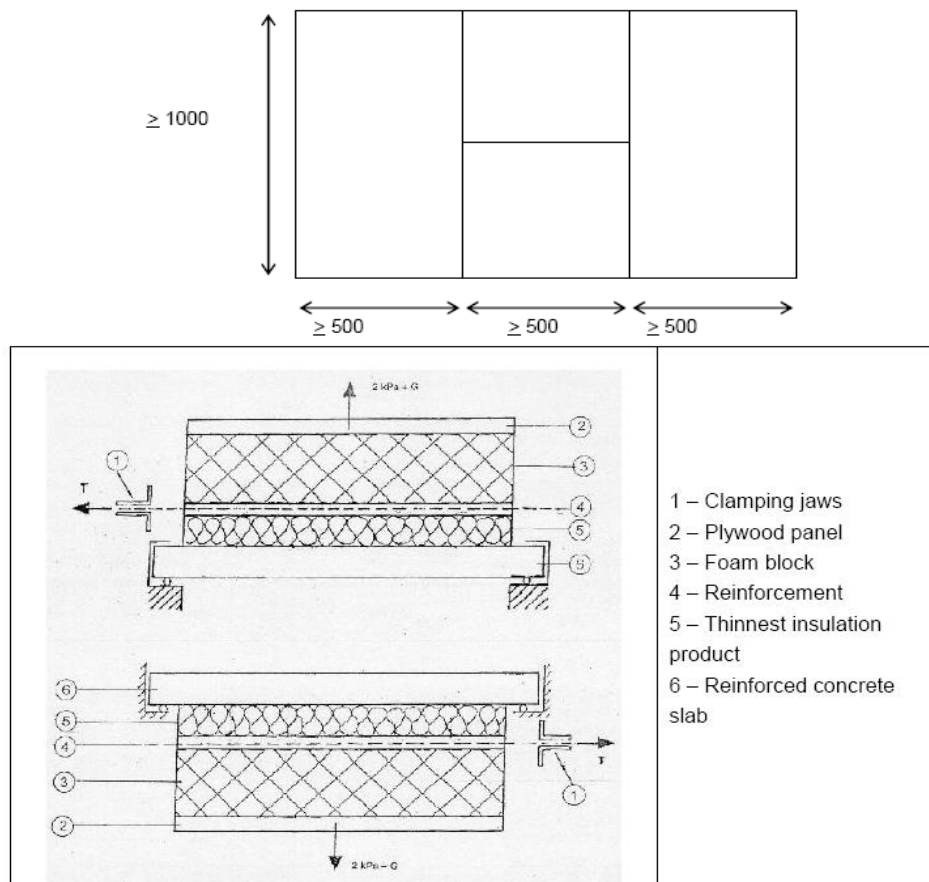

Fig. 7: Dimensions in mm and principle for preparation of specimens

Analysis of results:

The load/displacement curve is recorded, possibly until failure occurs and the displacement  $U_e$  corresponding to the limit of elasticity is determined (see Figure 8):

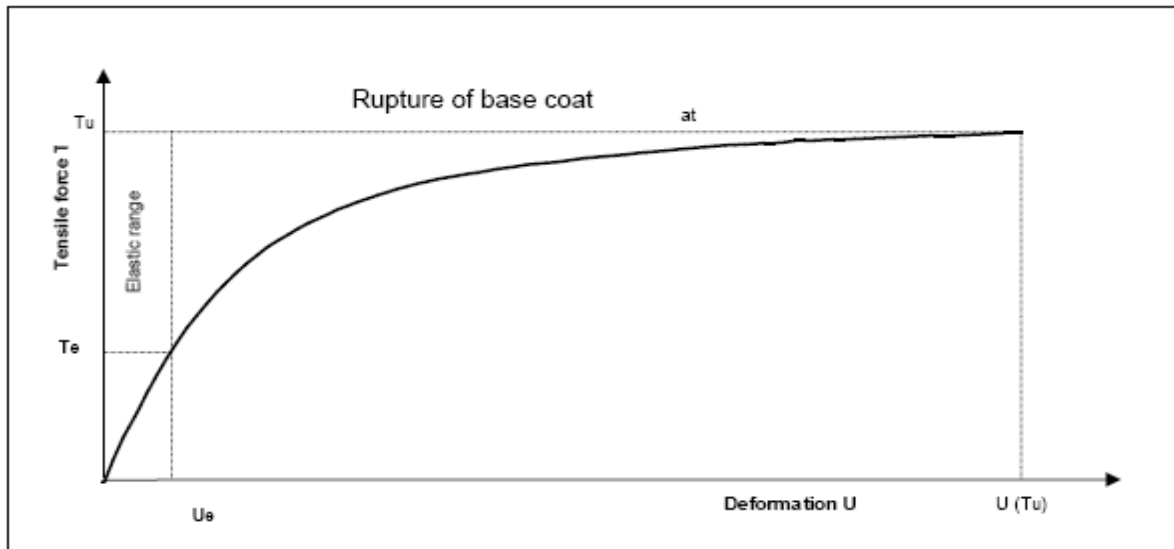

Fig. 8: Load/displacement curve

The Displacement  $U_e$  is to be stated in the ETA. Based on these data, the length of the wall or the distance between expansion joints can be calculated using the following equation as a function of the claimed  $\Delta T$ :

$$L = U_e / (\epsilon_s + \alpha_{th} \times \Delta T)$$

where  $U_e$  = displacement corresponding to the elasticity limit (see load/displacement curve)

$\epsilon_s$  = shrinkage

$\alpha_{th}$  = coefficient of linear thermal elongation ( $1 \times 10^{-5}$ )

$\Delta T$  = temperature variations in the reinforced base coat of rendering claimed by the Manufacturer.

L = length of wall or distance between expansion joints.

2.2.3.6 Wind load resistance of mechanically fixed ETICS

The test samples for both the Pull-through test of fixings (2.2.3.6.1) and the Static foam block test (2.2.3.6.2) are described in Figure 9, whereas the test samples for the Dynamic wind uplift test are described separately in the test description (2.2.3.6.3).

- (1) Pull through resistance of anchors placed at the body of the insulation product ( $R_{panel}$ ).

Test samples		Test methods
(1a)		Pull through test 2.2.3.6.1
or	<p style="text-align: right;"><math>a \geq 150 \text{ mm}</math></p>	
(1b)		Static foam block 2.2.3.6.2



- (2) Pull through resistance of anchors placed at the panel joint ( $R_{\text{joint}}$ ).

Test samples	Test methods
<p>(2a)</p> 	<p>Pull through test 2.2.3.6.1</p>
<p>or</p> <p>(2b)</p> 	<p>Pull through test 2.2.3.6.1</p> <p>Static foam block 2.2.3.6.2</p>

Fig. 9: Test samples for ETICS mechanically fixed by anchors (dimensions in mm)

The combination of tests (scheme 2b) shall be used only in case that pull-through resistance at panel joints ( $R_{\text{joint}}$ ) cannot be determined by the pull-through test due to unacceptable behavior of test specimens during the test.

When using the combination of tests (scheme 2b), the influence of anchors positioned at panel joints is then deduced by calculation  $R_{\text{joint}} = (F - 2 \times R_{\text{panel}}) / 6$

where:

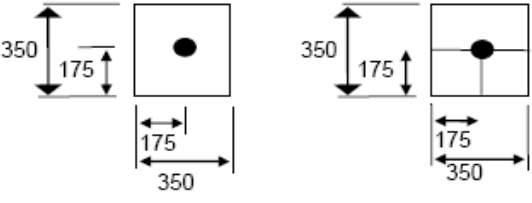
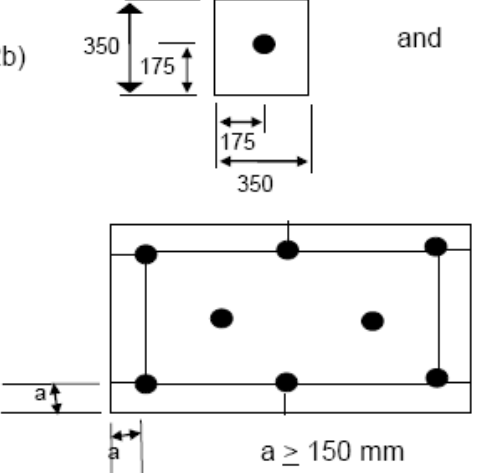
$F$  = maximum load by the foam block expressed as 5%-fractile

$R_{\text{panel}}$  = mean resistance at the body of the insulation product (determined by the pull-through test)

$R_{\text{joint}}$  = mean resistance at joint.

The tests are carried out at least on the thinnest insulation product envisaged to be covered by the ETA. For further evaluation of the test, the load/displacement graph shall be recorded.

### 2.2.3.6.1 Pull-through tests of fixings

The pull-through test of anchors is not required if the ETICS is a bonded one with anchors only used as supplementary device (see Table 3).

The test is performed in dry conditions.

However, if the tensile strength of the insulation product in wet conditions tested according to 2.2.3.8 is less than 80% of that determined in dry conditions, the Pull-through test shall be carried out in wet conditions as described in 2.2.3.8 "28 days exposure".

Insulation samples, measuring 350 mm x 350 mm, with an anchor driven through the centre of each sample (or at panel joints as described at the beginning of 2.2.3.6), are bonded, using a suitable adhesive, to a rigid substrate. The head of the anchor is covered previously with a self-release sheet.

When the adhesive has cured, a pulling force is exerted, at a loading rate of 20 mm/min between the rigid plate and the end of the anchor protruding through the insulation product until failure.

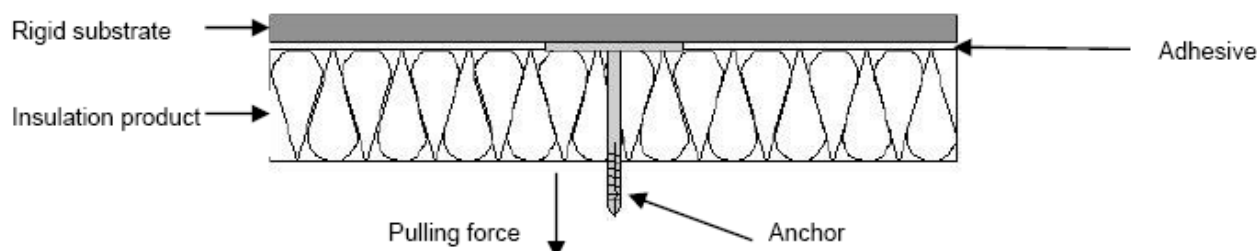

Fig. 10: Pull-through test sample

5 or more tests (depending on the dispersion of the results) shall be carried out. However, historical data obtained from testing of 3 samples may be used.

Results are void if the rupture occurs in the edge. In such cases, the dimensions of the sample shall be increased.

The test report shall detail:

- each individual and mean values expressed in N,
- load/displacement graphs for all test specimens,
- tensile strength perpendicular to the face of the insulation product tested (test result according to EN 1607).

#### 2.2.3.6.2 Static foam block test

The ETICS is applied on a timber frame or on timber frame with external boards without any supplementary adhesive, in accordance with the Manufacturer's instructions.

The dimensions shall be chosen according to the standard production size of the insulation product using the minimum thickness.

For ETICS secured by anchors, test samples are prepared in accordance with the Manufacturer's instructions and taking into account the influence of the anchors positioned at the panel joints as illustrated in 2.2.3.6 Wind load resistance.

For cellular plastic insulation product, 3 or more tests (depending on the dispersion of the results) shall be carried out.

For mineral wool insulation product, 5 or more tests (depending on the dispersion of the results) shall be carried out.

Test details are illustrated in Figure 11. The testing load  $F_t$  is generated by a hydraulic jack and transferred via a load cell to a plywood or other rigid panel. The loading speed shall be in the order of  $10 \pm 1$  mm/minute. The joists are fixed with timber screws to a plywood panel and the timber panel is glued to the foam blocks using a two-component epoxy adhesive. As the surface of the sample is not directly accessible, the displacement of the render surface is measured via an extension rod passing through a hole in one of the foam blocks.

The foam blocks shall be weak enough to follow all displacements of the coating without affecting the bending stiffness of the ETICS. Therefore the blocks are cut to rectangular pieces not exceeding 300 mm x 300 mm in width. The height of the blocks shall be at least 300 mm.

**Comment:** A suitable initial length of the block elements is 500 mm. The blocks can be cut off with a hot wire after the test is finished. They may be reused at least 20 times until the remaining length reaches about 300 mm.

The tensile strength of the material shall be in the range of 80 - 150 kPa, the rupture strain shall exceed 160%. The compressive strength according to ISO 3386-1 or -2 shall be in the order of 1.5 – 7.0 kPa. An example of a suitable material is polyester foam.

The test is carried out to failure in dry conditions.

However, if the tensile strength of the insulation product in wet conditions tested in 2.2.3.8 is less than 80% of that determined in dry conditions, this Static foam block test shall be completed as follows:

For mechanically fixed ETICS by anchors: Pull-through test carried out in wet conditions as described 2.2.3.8 "28 days exposure".

For mechanically fixed ETICS with profiles: Static foam block test after conditioning of the insulation product according to 2.2.3.8 "28 days exposure".

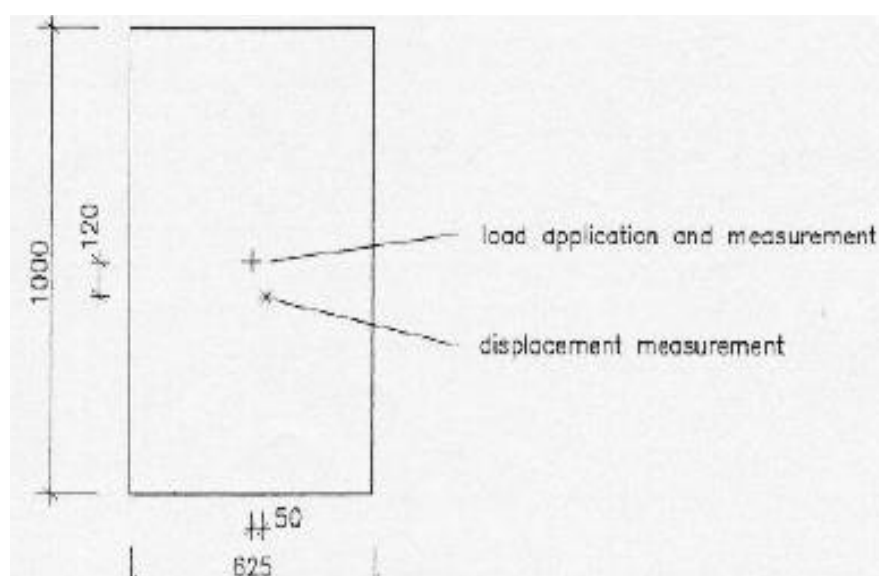
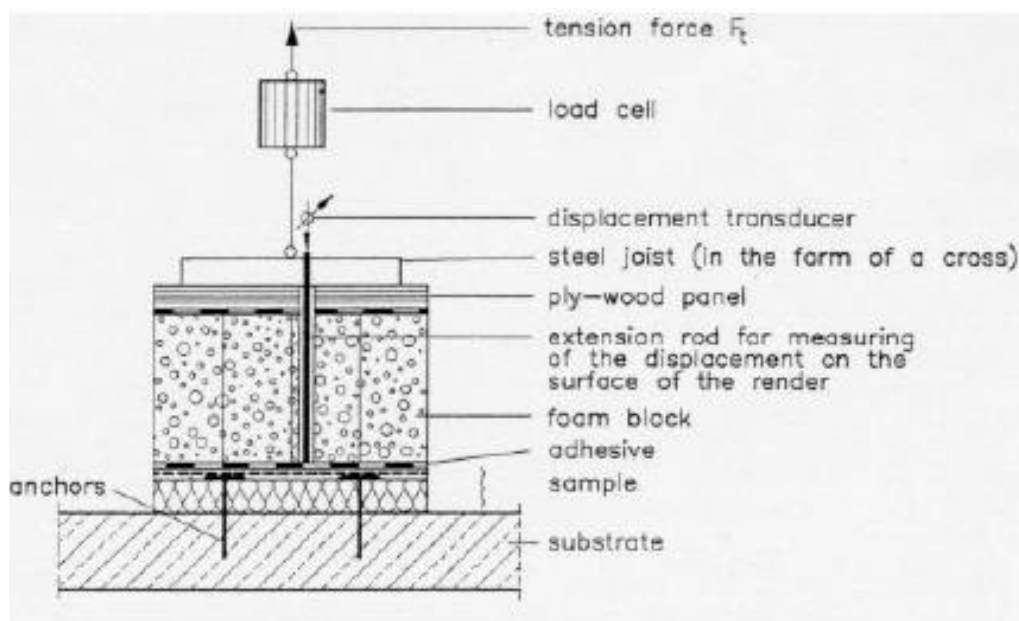

Fig. 11: Test set-up according to the "foam-block-method"

### 2.2.3.6.3 Dynamic wind uplift test

Preparation of the test specimen: according to the method of attachment.

a) Mechanically fixed insulation product:

The thinnest and thickest panels to be covered by the Assessment are tested.

To provide information about the resistance of the mechanical fixing devices and the bending or punching of the insulation product the thinnest panel is tested with the minimum number of fixing devices in the designated pattern.

To provide information about the adhesion of the rendering to the insulation product the thickest panel is tested with the maximum number of fixing devices in the designated pattern. The fixing devices of the insulation product specified by the Manufacturer are tested.

The panel submitted to the test should be of nominal dimensions.

Panels at the edge of the test box should be secured with additional fixing devices to prevent premature failure.

b) Bonded insulation product:

The test sample shall be built with the insulation product thickness corresponding to the lowest strength according to the tensile test (2.2.3.7 Tensile strength test perpendicular to the faces in dry condition).

General

The test model comprises:

- a substrate wall made from timber frame with or without boards with thickness with thickness greater than or equal to 250 mm with clamps for fixing to the rigid frame along the perimeter,
- the insulation product secured with the specified fixing devices for the ETICS,
- the rendering.

The dimensions of the test model shall be at least 2.0 m x 2.5 m.

For insulation product fixed with profiles the minimum dimensions are:

$(2a + 200 \text{ mm}) \times (4b + 200 \text{ mm})$ .

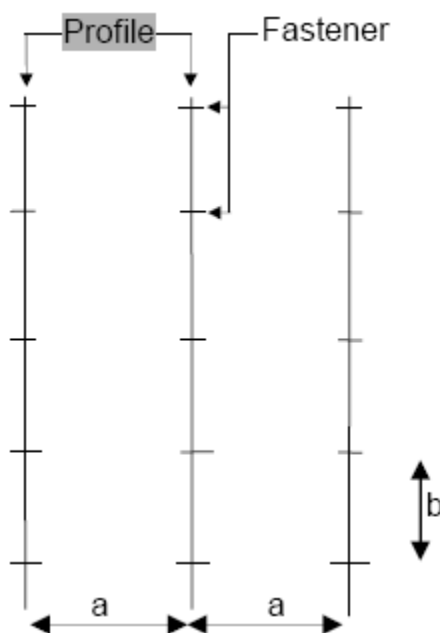

Fig. 12: Dimension of specimen

Test equipment

The test equipment consists of a suction chamber which is placed over the tested ETICS. The depth of the pressure chamber shall be sufficient for a constant pressure to be exerted on the tested ETICS irrespective of its possible deformation. The pressure chamber is mounted on a rigid frame which surrounds the tested ETICS, or on the ETICS itself. The rendering serves as the seal between the pressure chamber and the environment. The connection between the rendering and the chamber shall be sufficient to allow a realistic deformation of the tested ETICS under the influence of simulated wind uplift.

Test procedure

The loads shown in Figure 13 are applied, each gust having the profile shown in Fig. 14. The maximum suction of each cycle is  $W_{100\%}$  and is defined in the following Figures and Table 4:

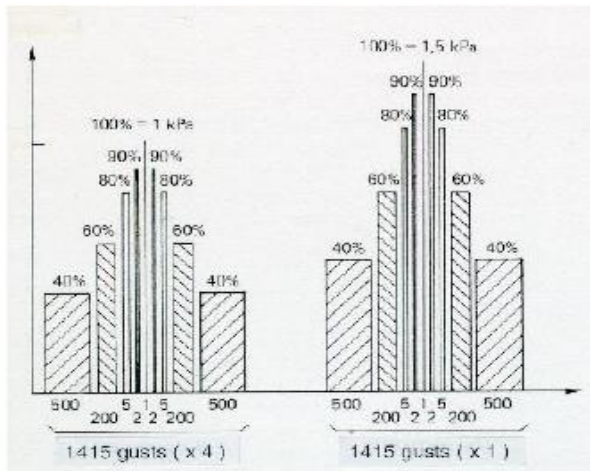

Fig. 13: loads to be applied

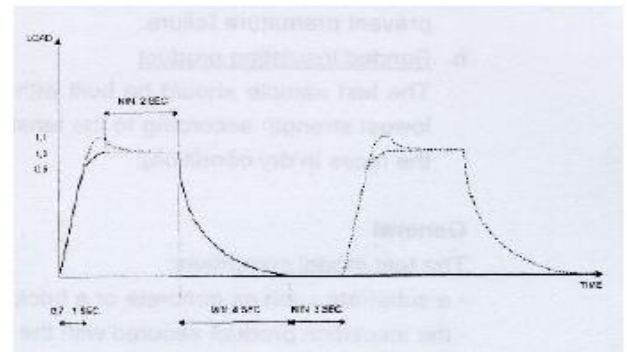

Fig. 14: pressure/time profile of cyclic loads

Number of cycles	Maximum suction in kPa
4	1,0
1	1,5
1	2,0
1	2,5
1	3,0
1	3,5
1	4,0
1	etc...

Table 4 - Maximum suction of the cycles  $W_{100\%}$

The sample is tested until failure:

Failure is defined by any one of the following events:

1. the insulation panel(s) breaks,
2. delamination occurs in the insulation product or between the insulation product and its facing,
3. the rendering system detaches,
4. the insulation panel is pulled off a fastener,
5. a mechanical fastener is torn out of the substrate,
6. the insulation panel detaches from the supporting structure. If failure occurs between the insulation panel and the substrate and the result is not satisfactory for the Manufacturer, the test may be repeated with a stronger bond made between the insulation panel and the substrate.

Test results

The test result  $Q_1$  is the  $W_{100\%}$  load in the cycle preceding that in which the test specimen fails.

The test result  $Q_1$  is corrected on the basis of the following formula to obtain the admissible value of the characteristic resistance  $R_k$ :

$$R_k = Q_1 \times C_s \times C_a$$

where:

$R_k$  = characteristic design resistance

$C_a$  = geometric factor allowing for the difference between the deformation of the ETICS in the test and the real deformation of the ETICS on a complete wall. This factor is used in other fields for very deformable skins. In the field of ETICS  $C_a = 1$ .

$C_s$  = statistical correction factor given in Table 5, Table 6 or below.

Bonding surface in % (S)	$C_s$
$50 \leq S \leq 100$	1
$20 < S < 50$	0,9

Table 5 -  $C_s$  for bonded insulation product

Number of fasteners in the insulation panel	NUMBER OF PANELS IN THE TEST BOX			
	1	2	3	4
2	**	0,90	0,95	0,97
3	0,85	0,95	0,97	0,98
4	0,90	0,97	0,98	0,99

Table 6 -  $C_s$  for insulation products mechanically fixed by anchors

\*\* Not admissible

The test results are only valid for those fixing patterns tested.

#### $C_s$ for insulation products mechanically fixed with profiles

The values of  $C_s$  as a function of the dimensions of the chosen tested ETICS are given below:

For	(3a + 200 mm) x (4b + 200 mm) and greater:	} $C_s = 0,95$
For	(4a + 200 mm) x (3b + 200 mm)	
and	(2a + 200 mm) x (5b + 200 mm)	} $C_s = 0,90$
and	(2a + 200 mm) x (6b + 200 mm)	
For	(2a + 200 mm) x (4b + 200 mm):	$C_s = 0,85$

The dimensions (2a + 200 mm) x (3b + 200 mm) are not allowed (in this case  $C_s$  will be less than 0.5).

#### 2.2.3.6.4 Resistance to soft body impact for ETICS directly mounted to the timber frame

The evaluation is done according to EOTA TR 001.

The following levels can be given:

- level A 500Nm no penetration
- level B 300Nm no collapse
- level C 100Nm no projection.

The maximum deflection shall be given in the ETA.

### 2.2.3.7 Tensile resistance of insulation product: in dry conditions

Only if no test method is defined in the appropriate harmonized technical specification for the relevant insulation product, the verification of tensile resistance shall be performed in accordance with EN 1607. The result in KPa shall be stated in the ETA.

### 2.2.3.8 Tensile resistance of insulation product: in wet conditions

Only if no test method is defined in the appropriate harmonized technical specification for the relevant insulation product, the verification of tensile resistance of insulation product in wet conditions shall be performed as described below. The results in KPa shall be stated in the ETA.

Where the characteristics of the insulation product could deteriorate by exposure to humidity, the test introduced in 2.2.3.1 shall be carried out in wet conditions.

The size of the test samples depends on the type of insulation product and should be identical to the test in dry conditions.

The testing is performed as a two test series with a minimum of 8 samples exposed to heat-moisture actions at  $(70 \pm 2)^\circ\text{C}$  and  $(95 \pm 5) \% \text{RH}$  in a climatic chamber:

- for 7 days followed by a drying period at  $(23 \pm 2)^\circ\text{C}$  and  $(50 \pm 5) \% \text{RH}$  until constant mass is achieved
- for at least 28 days followed by a drying period at  $(23 \pm 2)^\circ\text{C}$  and  $(50 \pm 5) \% \text{RH}$  until constant mass is achieved.

The tensile strength perpendicular to the face is determined after each conditioning and expressed in MPa. The value in KPa shall be stated in the ETA.

*Remark:* The mass is considered constant when the mass difference between two measurements carried out at intervals of 24 hours is within 5%.

### 2.2.3.9 Shear strength and shear modulus of elasticity of insulation product

Only if no test method is defined in the appropriate harmonized technical specification for the relevant insulation product, the verification of shear strength and shear modulus of elasticity of insulation product shall be performed in accordance with EN 12090 on a 60 mm thick sample. The result in  $\text{Nmm}^2$  shall be stated in the ETA.

### 2.2.3.10 Bending strength of insulation product directly mounted to the timber frame.

Only if no test method is defined in the appropriate harmonized technical specification for the relevant insulation product, the verification of bending strength of insulation product, shall be performed in accordance with EN 12089 “Determination of bending behaviour”. The result shall be stated in the ETA.

### 2.2.3.11 Dimensional stability

Only if no test method is defined in the appropriate harmonized technical specification for the relevant insulation product and if no related values accompany the CE marking of the product, the verification of dimensional stability of insulation product, shall be performed as follows: for PF and ICB insulation also the test of determination of dimensional stability under constant normal laboratory conditions according to EN 1603 and determination of dimensional stability under specified temperature and humidity according to EN 1604 have to be envisaged.

### 2.2.3.12 Tensile strength of rendering system

#### *Purpose*

The Render Strip Tensile Test is suitable for the assessment of the crack behavior of the reinforced base coat by determination of the crack width distribution and the "characteristic crack width"  $W_{rk}$  at completed cracking.

#### *Test set-up*

A render strip sample has the size 600 mm x 100 mm x  $d_r$  and consists of the reinforcement and the base coat ( $d_r$  = thickness of the base coat with embedded reinforcement). The reinforcement with a length of 800 mm is arranged within the base coat according to the Manufacturer's instructions. It shall protrude about 100 mm at both ends. The protruding parts of the reinforcement are placed on the render surfaces on which two metal plates are glued (if the reinforcement is not in the middle, two strips shall be glued to a double symmetrical specimen where the thinner parts of the strips are in the middle of the specimen).

As an alternative to bonding the specimen between two steel plates the fixing of the test sample can be done using a PVC foil (thickness 1.5 to 2 mm, Shore-A-hardness 82) and pneumatic/hydraulic clamping device (see Figure 15).

The test is performed in warp and weft direction on three render strips each. The number of threads in one direction shall be the same for all the three strips.

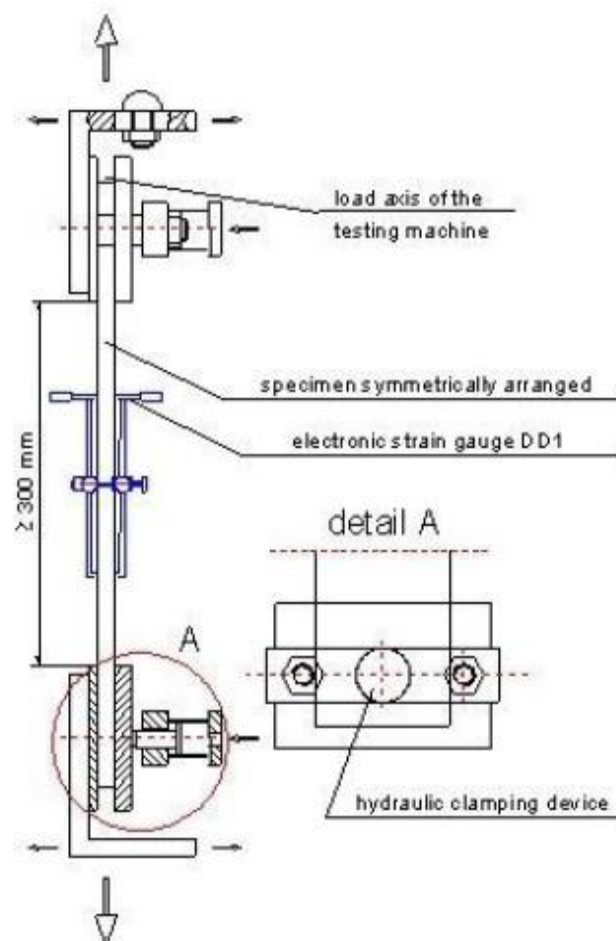

Fig. 15: Test set-up for the Render Strip Tensile Test

#### Execution of the test:

The tensile force is applied deformation-controlled with a rate of strain of 0.5 mm/min. The force is measured via a static uniaxial tensile testing machine (class 1). The displacements are measured by two electronic displacement gauges DD1 for  $\pm 2.5$  mm, precision class 0.1. The length of the measuring distance shall amount to at least 100 mm. The measuring points shall be arranged such that they are at



least 75 mm off the outer limits of the load introducing elements. The gauge length shall be 150 mm and such that it is at least 75 mm away from the peaks of the metal plates. The two electronic displacement gauges are fixed the same way on the front and backside and/or the face sides of the specimen with the possibility of a separate analysis of the measurement results.

The render strips are loaded 10 times up to 50 % of the crack strength expected, for organic rendering systems up to a maximum of 250 N per test strip. Loading and release shall last about 1 to 2 minutes. During the 11th cycle the render strips are loaded until cracking and subsequently until failure. If no early failure occurs, the loading process is interrupted at render strain values of 0.3 %, 0.5 %, 0.8 %, 1.0 %, 1.5 %, and 2.0 %. The quantity of cracks within the metering range is counted and recorded. The crack width shall be classified with the frequency occurred in the crack developing record (see Figure 15) in categories of  $\leq 0.05$  mm,  $\leq 0.10$  mm,  $\leq 0.15$  mm,  $\leq 0.20$  mm,  $\leq 0.25$  mm, and  $> 0.25$  mm. The maximum crack width  $W_{\max}$  measured in each case shall be recorded with an accuracy of 1/100 mm.

It is recommended to measure the crack width with a magnifier with fiftyfold magnification; an exaggerated preciseness is not appropriate due to the irregularities of the cracks.

Sample	$\epsilon$ [% ]	Number of cracks on sample side A with a crack width of w[mm]							Number of cracks on sample side B with a crack width of w[mm]								
		$\leq 0,05$	$\leq 0,10$	$\leq 0,15$	$\leq 0,20$	$\leq 0,25$	$> 0,25$	max.	$\Sigma$ cracks	$\leq 0,05$	$\leq 0,10$	$\leq 0,15$	$\leq 0,20$	$\leq 0,25$	$> 0,25$	max.	$\Sigma$ cracks
1.0.1	0.3																
	0.5																
	0.8																
	1.0																
	1.5																
	2.0																

Fig. 16: Crack developing record for the tension test with render strip

#### Analysis of test results:

In the **exact procedure (I)** the related constituent equations are derived from the recorded load-strain diagram for the warp and weft direction. The render strain  $\epsilon_{rk}$  with completed cracking can be read from that. For this state of expansion, however, at least at 0.5 % expansion the characteristic crack width  $w_{rk}$  is determined from all the test results on hand as 95 % quantile with 75% confidence level in the specified operational steps following hereinafter. In doing so intermediate values can be interpolated linearly.

- Determination of the strain  $\epsilon_{rk}$  with "completed cracking" (constituent equations derived from the load-strain diagrams);  $\epsilon_{rk} \geq 0.5$  %.
- Number of sample sides and measured crack widths per render tension state from the recorded crack developing record (see Figure 16).
- Determination of the mean value of the crack widths  $w_{m,l}$  measured at expansion state  $\epsilon_{rk}$  of the "completed cracking". In addition it is possibly necessary to consider the next higher and lower state and to linearly interpolate the crack widths measured.
- For the mean value  $w_m$  determined of the crack width the respective standard deviation  $s$  is determined.
- Depending on the number of tests and the confidence level of 75 % for experimental analyses on ETICS the  $k$  value for the 95 % quantile results from statistical data sheets:

<b>n =</b>	3	4	5	6
<b>k =</b>	3.15	2.68	2.46	2.34

- Calculation of the "characteristic crack width":  $w_{rk} = w_m + s \cdot k$

In the **simplified procedure (II)** the characteristic crack width for  $\varepsilon'_{rk} = 0.8 \%$  is determined as 95 % quantile with 75 % confidence level in the specified operational steps following hereinafter.

- Determination of the mean value of the crack width  $w_m$  at tension state  $\varepsilon'_{rk} = 0.8 \%$ .
- For the mean value  $w_m$  determined of the crack width the respective standard deviation  $s$  is determined.
- Depending on the number of tests and the confidence level of 75 % for experimental analyses on ETICS the  $k$  value for the 95 % quantile results from statistical data sheets:

<b>n =</b>	3	4	5	6
<b>k =</b>	3.15	2.68	2.46	2.34

- Calculation of the "characteristic crack width":  $w_{rk} = w_m + s \cdot k$

For organic rendering systems without observed crack width the elongation at rupture  $\varepsilon_{ru}$  and the respective ultimate load  $N_{ru}$  shall be determined as a mean value for each of the individual test.

### 2.2.3.13 Pull-out strength of fixing from profiles

The verification of pull-through resistance of fixings from profiles used as ancillary materials (base profiles, corner profiles ...) is not required.

The pull-through resistance of a fixing (anchor) through the perforation in the profile is verified as follows: the test is carried out on 5 samples each measuring  $300 \text{ mm} \pm 20 \text{ mm}$  with a 6 mm perforation in the centre, obtained by drilling.

The apparatus consists of:

- a dynamometer,
- a support and metal screw as shown in Figure 17.

The samples are conditioned for at least 2 h at  $(23 \pm 2)^\circ\text{C}$  before the test.

The screw is placed perpendicular to the profile as described in Figure 17.

The tensile strength is carried out at  $(23 \pm 2)^\circ\text{C}$ .

The tensioning speed is 20 mm/min.

The individual and mean pull-through resistances are recorded and the results expressed in N.

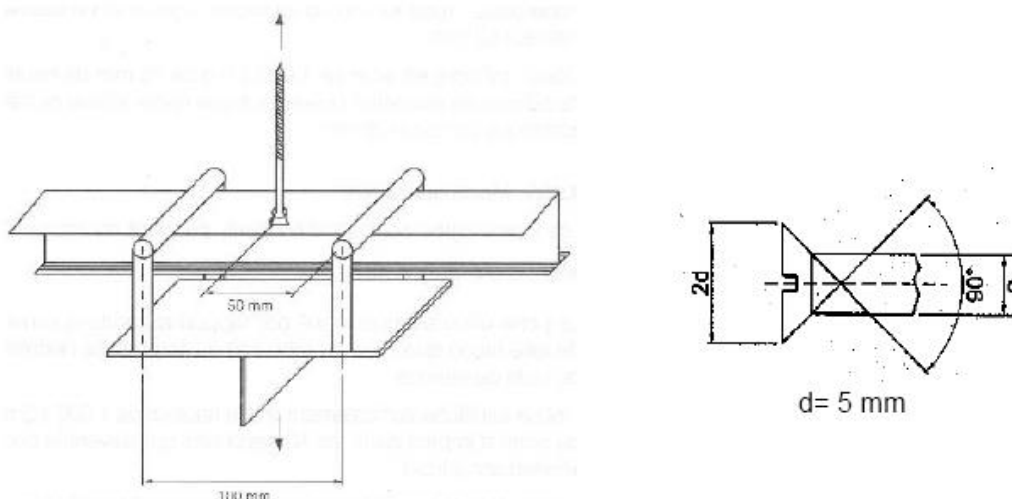

Fig. 17: Profile pull-through test

### 2.2.3.14 Pull-out strength of mechanical fixings (anchors, staples, screws, etc.)

For mechanically fixed ETICS, the pull-out strength of mechanical fixings (anchors, staples, screws etc) shall be verified in accordance with EN 1382 “Withdrawal capacity of timber fasteners”.

### 2.2.3.15 Hardened base coat: Dynamic modulus of elasticity and shrinkage behaviour of hardened base coat with a thickness greater than 5 mm

#### *Preparation and storing of test samples*

The mortar is prepared by mixing as described in 3.4.1.2.

Test samples, conforming to the dimensions defined in the paragraphs below, are prepared in metal moulds in two layers.

Each layer is compacted into position by dropping alternately each side of the mould from a height of 5 mm approximately ten times. The test samples are then levelled with a metal ruler.

The test samples are removed from the mould after 24 h.

They are then stored for at least 28 days at  $(23 \pm 2)^\circ\text{C}$  and  $(50 \pm 5) \%$  relative humidity.

#### Dynamic modulus of elasticity (Resonance frequency method)

The dynamic modulus of elasticity is determined on prismatic test samples measuring 25 mm x 25 mm x 285 mm.

The test is carried out on the following:

- 3 samples prepared as described in 3.4.1.2
- 3 samples prepared with product taken at the time of the preparation of the rig described (2.2.2.2).

The individual values of the apparent density (in  $\text{kg/m}^3$ ) and the modulus (in MPa) of the 3 test samples and the mean value of the results obtained are noted.

The principle of the measurement consists of measuring the basic resonance frequency of a test sample under longitudinal vibration.

#### 1 - Apparatus

The apparatus used for carrying out this measurement comprises:

- a) A variable frequency oscillator, with a frequency range of 20 kHz and a precision of 1%.
  - b) An electromagnetic vibrator which may or may not be in mechanical contact with the test sample; its mass shall be very light compared to that of the test sample.
  - c) A receiver, an electromechanical transducer and an amplifier; its mass shall be very light compared to that of the test sample.
- The resonance frequencies of the vibrator and the receiver shall not fall between 0.5 kHz and 20 kHz.
- d) An amplifier.
  - e) An apparatus indicating the vibration amplitudes (voltmeter, milliammeter, oscilloscope).
  - f) A very narrow support on which the test sample rests during the measurement, which shall not hinder the longitudinal vibration of the test sample and which shall be in the nodal plane.

#### 2 - Testing

The sample is centred on the support. The vibrator and the receiver are placed as shown below:

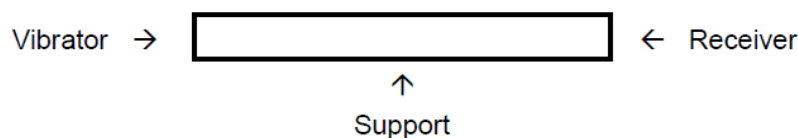

It is important that the ends of the test piece are free to vibrate in an axial direction. The vibration generator and the receiver, if they are in contact with the test piece, should exert an equal very weak stress on the two ends. In this case, it is recommended to weakly bond the mobile part of the vibrator to the sample using a coupling product (mastic). The same applies for the receiver.

The variable frequency oscillator supplies the vibrator and the test piece vibrates longitudinally. The vibrations are collected by the receiver and after amplification their amplitude is shown on a dial (voltmeter,

milliammeter, oscilloscope). For most frequency ranges, the vibration amplitude is quite small. But for certain frequencies, the displacement becomes appreciable. The resonance conditions are created when a maximum amplitude is obtained on the indicating dial.

The frequency of the basic longitudinal resonance corresponds to the lowest frequency for which a maximum amplitude is obtained (for the higher harmonic frequencies a resonance is also produced). Two measurements are carried out: the vibration is produced successively at the two ends of the test piece. The mean value is recorded. If the difference between the two values is higher than 5 % the vibrations are restarted.

The measurements of the mass and dimensions of the test piece are needed to calculate the modulus. The precision for weighing is 1/1000 and for the dimensions 1/100.

#### *Expressing the results*

As the basic longitudinal resonance frequency, the mass and the dimensions of the test piece are known the dynamic modulus of elasticity is determined using the following formula:

$$E_d = 4L^2 \cdot F^2 \rho \cdot 10^{-6}$$

- $E_d$  = Longitudinal dynamic modulus of elasticity in Newtons per square millimetre.
- $L$  = Length of test piece in metres.
- $F$  = Longitudinal resonance frequency in Hertz.
- $\rho$  = Mass per unit volume in kg/m<sup>3</sup>.

#### Shrinkage test

The measurement is carried out on three samples of base coat measuring 20 mm x 40 mm x 160 mm prepared and stored as described in 3.4.1.2 by inserting measuring spindles in the front end (10 mm x 40 mm) of the samples. Measurements are carried out at regular intervals. The value after 28 days is recorded. In addition if there is doubt in the curve associated with stabilisation, the test is continued and the value after 56 days is recorded.

#### 2.2.3.16 Hardened base coat: Static modulus of elasticity, tensile strength and elongation at break for products with a thickness up to 5 mm

The tests are performed on test samples measuring 3 mm x 50 mm x 300 mm.

Moulds for the samples are made using appropriately positioned 3 mm thick strips of extruded polystyrene adhered to expanded polystyrene boards.

After the base coat, without reinforcement has dried, test samples are cut from the polystyrene with hot wire.

The test sample is subjected to a tensile test until it breaks using a suitable machine which records the tensile stress and elongation. The distance between the jaws of the machine is 200 mm. The sample is held between the jaws with the interposition of pads.

The tensioning speed is 2 mm/minute.

The tests are carried out on five samples stored for at least 28 days at (23 + 2)°C and (50 + 5)% RH and on five samples which have undergone the hygrothermal test (placed in the window of the rig).

#### 2.2.3.17 Shear strength and shear modulus of foam adhesives

The shear strength and shear modulus shall be determined according to EOTA Technical Report 046 "Test methods for foam adhesives for ETICS".

### 2.2.3.18 Post expansion behaviour of foam adhesives

The post expansion behaviour shall be determined according to EOTA Technical Report 046 "Test methods for foam adhesives for ETICS".

### 2.2.3.19 Impact resistance of the ETICS

The hard body impact test shall be performed on the rig after the heat-rain and the heat-cold cycles.

The hard body impact tests shall be performed as described in ISO 7892. The points of impact are selected taking into account various modes of behaviour of walls and their cladding, varying according to whether the impact point is or is not located in an area of greater rigidity (reinforcement).

Hard body impacts (10 Joules) are carried out on 3 samples with the steel ball weighing 1.0 kg and from a height of 1.02 m.

Hard body impacts (3 Joules) are carried out on 3 samples with the steel ball weighing 0.5 kg and from a height of 0.61 m.

For finishing coats not tested on the rig or for complementary tests (double meshes, etc), these tests can also be carried out on samples aged by immersion in water for 6 to 8 days and then dried for at least 7 days at  $(23 \pm 2)^{\circ}\text{C}$  and  $(50 \pm 5)\%$  RH. Within a type of finishing coat, the test shall be carried out with at least the thinnest layer (generally the lowest particle size grading with ribbed finishing aspect).

In case of test with reinforced mesh, the extrapolation of results to very different products (other mesh size, other mass per unit area, etc) shall be carefully examined.

In case of possible optional use of key coat and/or decorative coat, at least the configurations without them shall be tested.

The following observations have to be made:

- the diameter of the impact is measured and indicated,
- the presence of any micro cracks or cracks, at the impact point and at the circumference, is noted.

### 2.2.3.20 Bond strength after ageing of ETICS: finishing coat tested on the rig

The bond test is carried out on the rig after the hygrothermal cycles (heat-rain and heat-cold cycles) and at least 7 days drying. Five squares are cut through the rendering system up to the substrate interface according to Figure 18, using an angle grinder. The dimensions should be the same as the samples for testing the tensile strength perpendicular to the faces according to the respective technical specification of the insulation product. Metal plates of appropriate size are bonded to it using a suitable adhesive.

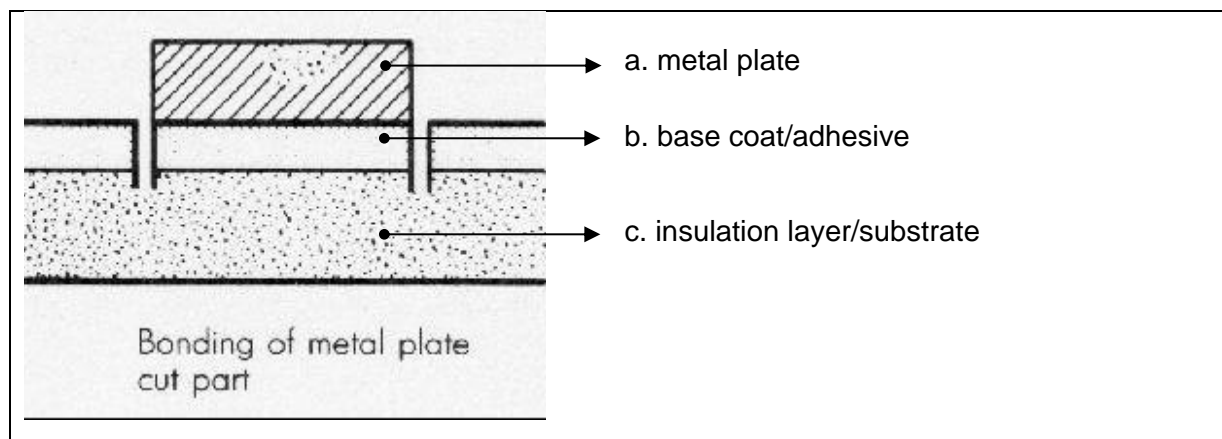

Fig. 18: Bonding of metal plate cut part

Afterwards, the failure resistance (2.2.3.1) is measured at a tensioning speed of 1 to 10 mm/minute. The individual and mean values are recorded and the results expressed in  $\text{N}/\text{mm}^2$  (MPa).

### 2.2.3.21 Bond strength after ageing of ETICS: Finishing coat not tested on the rig

The test is performed on an insulation panel faced with the rendering system applied in accordance with the manufacturer's instructions.

After allowing the samples to dry at  $(23 \pm 2)^\circ\text{C}$  and  $(50 \pm 5) \% \text{RH}$  for at least 28 days, five squares are cut through the rendering system up to the substrate interface according to Figure 18 using an angle grinder. The dimensions should be the same as the samples for testing the tensile strength perpendicular to the faces according to the respective technical specification of the insulation product.

The test shall be performed:

- on samples aged by immersion in water for 7 days and then dried for at least 7 days at  $(23 \pm 2)^\circ\text{C}$  and  $(50 \pm 5) \% \text{RH}$ .

and/or

- if freeze-thaw cycles necessary according to 2.2.2.1: on the samples after the freeze-thaw cycles as foreseen in 2.2.2.3 and dried for at least 7 days after the end of the cycles .

In case of possible optional use of key coat and/or decorative coat, at least the configurations without the key coat and/or the decorative coat shall be tested.

Metal plates of appropriate size are bonded to the squares using a suitable adhesive.

Afterwards, the failure resistance (2.2.3.1) is measured at a tensioning speed of  $10 \pm 1 \text{ mm/minute}$ .

The individual and mean values are recorded and the results expressed in  $\text{N/mm}^2$  (MPa).

### 2.2.3.22 Protection against corrosion of mechanical fixings

Corrosion protection of metal fasteners corresponds to the requirements of the intended service class (see EN 1995-1-1 and the corresponding reference standards). For especially corrosive conditions consideration should be given to heavier hot dip coatings or stainless steel.

### 2.2.3.23 Tearing strength and elongation of reinforcement: glass fibre mesh

The tensile strength and the elongation of the reinforcement are to be measured in the weft and warp directions on 10 samples respectively. The samples should measure 50 mm by at least 300 mm. They shall contain at minimum 5 threads within the width.

The clamps of the testing machine shall be covered with a suitable rubber surface and hold the whole width of the samples. They shall be sufficiently rigid to resist deformation during the test.

The sample shall be located perpendicular to the clamp of the tensile testing machine.

The free length of the sample between clamps should be 200 mm. The tensile force is increased with a constant crosshead speed of  $(100 \pm 5) \text{ mm/min}$  until failure occurs.

Testing is done in the as-delivered state and after immersion in alkaline solution (ageing).

The strength in N at failure and the elongation are recorded.

Samples where the specimen is displaced within the clamps or where the failure occurs at the clamps shall be discarded.

Calculation is undertaken to determine:

- the individual values of the tensile strength calculated from the force (F) at failure in relation to the width (w) of the sample:

$$\beta = \frac{F}{w} \text{ in N/mm}$$

- the individual values of elongation calculated from the change of the length  $\Delta l$  at failure in relation to the length  $l$  of the sample between the clamps

$$\varepsilon = \frac{\Delta l}{l} \text{ in \%}$$

- the mean values of tensile strength and elongation calculated from these individual values
- the residual value calculated from the mean tensile strength value after ageing in relation to the mean tensile strength value in the as-delivered state.

#### *Testing in the as-delivered state*

The test is conducted after conditioning the samples at  $(23 \pm 2)^\circ\text{C}$  and  $(50 \pm 5) \% \text{RH}$  for at least 24 hours.

#### *Testing after ageing*

The samples are immersed for 28 days in alkaline solution at  $(23 \pm 2)^\circ\text{C}$  (20 samples (10 in the weft and 10 in the warp direction) in 4 litres solution.

The composition of the solution is as follows:

1 g NaOH, 4 g KOH, 0.5 g Ca (OH)<sub>2</sub> to one litre of distilled water.

The samples are rinsed by immersion for 5 minutes in acid solution (5 ml HCl (35 % diluted) to 4 litres water) and then placed successively in 3 baths of water (4 litres each). The samples are left for 5 minutes in each bath.

They are subsequently dried at  $(23 \pm 2)^\circ\text{C}$  and  $(50 \pm 5) \% \text{RH}$  for 48 hours.

### 2.2.3.24 Tearing strength and elongation of reinforcement: metal lath or mesh

For galvanised steel reinforcement, the minimum thickness of the zinc coat required is verified using the relevant EN method.

EN ISO 1460: Metallic coatings - Hot dip galvanized coatings on ferrous materials - Gravimetric determination of the mass per unit area.

EN ISO 1461: Metallic coatings - Hot dip galvanized coatings on fabricated iron and steel articles - Specifications and test methods.

EN 10244-2: Steel wire and wire products – Non-ferrous metallic coatings on steel wire- Part 2: Zinc or zinc alloy coatings.

### 2.2.3.25 Tearing strength and elongation of other reinforcement

Depending on the type of material, the Assessment Body will perform a suitable test based on 2.2.3.23.

## **2.2.4 Protection against noise**

### 2.2.4.1 Airborne sound insulation of ETICS

The acoustic performance of an ETICS shall be determined on the basis of laboratory tests carried out in accordance with the standards EN ISO 10140-1, EN ISO 10140-2, EN ISO 10140-4 and EN ISO 10140-5. The ETICS shall be tested on the relevant type of wall according to EN ISO 10140-1, Annex G.2 c).

The direct difference of the weighted sound reduction indices of the wall with and without the ETICS,  $\Delta R_{W,direct}$ ,  $\Delta(R_W + C)_{direct}$  and  $\Delta(R_W + C_{tr})_{direct}$ , shall be reported as evaluated according to EN ISO 10140-1 Annex G together with the description of the wall used for testing.

For the configuration of the ETICS to be tested, the following rules shall be taken into account:

- insulation products with higher dynamic stiffness provide worse performance
- insulation products with lower air flow resistance provide worse performance
- a higher number of fixings provides worse performance
- a higher adhesive surface coverage provides worse performance
- a higher mass of a rendering system provides better performance

- a greater thickness of the insulation product provides better performance
- the performance for an insulation product thickness between two tested ones can be linearly interpolated
- anchors with plastic screws/nails provide better performance than with metal screws/nails.

#### 2.2.4.2 Dynamic stiffness of insulation product

If no test method is defined in the appropriate harmonized technical specification for the relevant insulation product, the test shall be performed in accordance with EN 29052-1 without preloading.

### 2.2.5 Energy economy and heat retention

#### 2.2.5.1 Thermal resistance and thermal transmittance of the ETICS

The additional thermal resistance provided by the ETICS ( $R_{ETICS}$ ) to the substrate wall is calculated from the thermal resistance of the insulation product ( $R_{insulation}$ ), determined in accordance with 2.2.5.2, and from either the tabulated R render value of the render system ( $R_{render}$  is about 0.02 m<sup>2</sup>K/W) or  $R_{render}$  determined by test according to EN 12667 or EN 12664 (depending on expected thermal resistance).

$$R_{ETICS} = R_{insulation} + R_{render} \text{ [(m}^2 \cdot \text{K)/W]}$$

as described in EN ISO 6946 and EN ISO 10456.

If the thermal resistance cannot be calculated, it can be measured on the complete ETICS as described in EN 1934.

The thermal bridges caused by mechanical fixing devices influence the thermal transmittance of the entire wall and shall be taken into account using the following calculation:

$$U_c = U + \Delta U \text{ [W/(m}^2 \cdot \text{K)]}$$

With:  $U_c$  corrected thermal transmittance of the entire wall, including thermal bridges  
 $U$  thermal transmittance of the entire wall, including ETICS, without thermal bridges

$$U = \frac{1}{R_{ETICS} + R_{substrate} + R_{se} + R_{si}}$$

$R_{substrate}$  thermal resistance of the substrate wall [(m<sup>2</sup>·K)/W]

$R_{se}$  external surface thermal resistance [(m<sup>2</sup>·K)/W]

$R_{si}$  internal surface thermal resistance [(m<sup>2</sup>·K)/W]

$\Delta U$  correction term of the thermal transmittance for mechanical fixing devices

=  $\chi_p \cdot n$  (for anchors) +  $\sum \psi_i \cdot l_i$  (for profiles)

$\chi_p$  point thermal transmittance value of the anchor [W/K]. See Technical Report n°25. If not specified in the anchors ETA, the following values apply:

= 0.002 W/K for anchors with a plastic screw/nail, stainless steel screw/nail with the head covered by plastic material, and for anchors with an air gap at the head of the screw/nail.

= 0.004 W/K for anchors with a galvanized steel screw/nail with the head covered by a plastic material

= 0.008 W/K for all other anchors (worst case)

$n$  number of anchors per m<sup>2</sup>

$\psi_i$  linear thermal transmittance value of the profile [W/(m·K)]

$l_i$  length of the profile per m<sup>2</sup>.

The influence of thermal bridges can also be calculated as described in EN ISO 10211.

It shall be calculated according to this standard if there are more than 16 anchors per m<sup>2</sup> foreseen. The declared  $\chi_p$ -values do not apply in this case.



### 2.2.5.2 Insulation products: thermal resistance

Evaluated according to the European standard for the relevant insulation product. If no test method is defined in the appropriate harmonized technical specification for the relevant insulation product, the test shall be performed in accordance with EN 12667 or EN 12939.

### 2.2.5.3 Air flow resistance of insulation product

The air flow resistance shall be determined for porous insulation material (e.g. mineral wool) only. If no test method is defined in the appropriate harmonized technical specification for the relevant insulation product, the test shall be performed in accordance with EN 29053.

### 3. ASSESSMENT AND VERIFICATION OF CONSTANCY OF PERFORMANCE

#### 3.1 System(s) of assessment and verification of constancy of performance to be applied

For the products covered by this EAD the applicable European legal act is: Decision 1997/556/EC.

The system is: 2 +.

In addition, with regard to reaction to fire for products covered by this EAD the applicable European legal act is Decision 1997/556/EC as amended by Decision 2001/556/EC.

The systems 1 and 2+ apply to ETICS with regard to reaction to fire.

The systems of AVCP referred to above are defined as follows:

System 1 for ETICS for which the following is valid:

- intended use in external walls subject to reaction to fire regulations,
- reaction to fire classes A1, A2, B or C,
- made of materials for which a clearly identifiable stage in the production process results in an improvement of the reaction to fire classification (e.g. an addition of fire retardants or a limiting of organic material).

#### 3.2 Tasks of the manufacturer

The cornerstones of the actions to be undertaken by the manufacturer of ETICS for timber frame building in the procedure of assessment and verification of constancy of performance are laid down in Table 7.

Table 7: Control plan for the manufacturer: cornerstones

No	Subject/type of control (product, raw/constituent material, component - indicating characteristic concerned)	Test or control method	Criteria, if any	Minimum number of samples	Minimum frequency of control
<b>Factory production control (FPC)</b> <b>[including testing of samples taken at the factory in accordance with a prescribed test plan]</b>					
1	Adhesive and base coat	<u>Powder and/or fresh mortar</u> - Density - Particle size grading - Bond test between adhesive/base coat and insulation product <u>Paste</u> - Density - Dry extract at 105°C* - Ash content at 450°C* - Viscosity - Bond test between adhesive/base coat and insulation product <u>Foam products</u> - Density - Appearance - Dimensional stability - Compression strength - Bond strength - Tensile strength	See 3.4.1 and 3.4.2	3	Density, Dry extract, Ash content at 450°C, Viscosity, Particle size grading, appearance. The frequency is determined case by case depending on the components, the variation in the volume produced and the production process ----- Compression strength, Bond strength, Tensile strength = once a year

No	Subject/type of control (product, raw/constituent material, component - indicating characteristic concerned)	Test or control method	Criteria, if any	Minimum number of samples	Minimum frequency of control
<b>Factory production control (FPC)</b> <b>[including testing of samples taken at the factory in accordance with a prescribed test plan]</b>					
2	Insulation Product	- Dimension, thickness	See 3.4.3	3	Each delivery
		- Mass per unit - Tensile strength - Compression test - Dimensional stability test (not necessary for mineral wool) - Thermal properties - Water vapour permeability		//	Each delivery: control of the suppliers documents envisaged by the related product EN
3	Mesh	- Mass per m <sup>2</sup> - Ash content*	See 3.4.4	3	Each delivery
		- Initial tensile strength - Alkali resistance (glass fibres) - Corrosion (metallic fibres)		//	Each delivery: control of the suppliers documents
4	Finishing coat	<u>Powder and/or fresh mortar</u> - Density - Viscosity (on fresh mortar) - Particle size grading - Visual aspect <u>Paste and/or fresh mortar</u> - Density - Dry extract at 105°C* - Ash content at 450°C* - Visual aspect	See 3.4.1	3	As Adhesive and base coat
5	Anchor	In accordance with relevant ETAs, if any; otherwise: dimensional controls and control of documents about performances provided from the suppliers. See 3.4.5			
6	Profiles	<u>PVC profiles</u> - Softening temperature - Mass per unit - Dimensions - Ash content (for plastic profile only) <u>Aluminium profiles</u> To be agreed with the NB	See 3.4.5	//	Each delivery: control of the suppliers documents

Parameters indicated by \* in the table for certain components are used to check the consistency of the reaction to fire of the ETICS.

Furthermore, the reaction to fire of the insulating material itself shall be verified.

- Some primary characteristics can be controlled by the determination of secondary characteristics whose correlation has been proved (example: thermal properties by determination of density).
- For components not defined in this table suitable tests shall be adopted.

Where materials/components are not manufactured and tested by the supplier in accordance with agreed methods, then where appropriate they shall be subject to suitable checks/tests by the manufacturer before acceptance.

### 3.3 Tasks of the notified body

The cornerstones of the actions to be undertaken by the notified body in the procedure of assessment and verification of constancy of performance for ETICS for timber frame building are laid down in Table 8.

Table 8: Control plan for the notified factory production control certification body: cornerstones

No	Subject/type of control (product, raw/constituent material, component - indicating characteristic concerned)	Test or control method	Criteria, if any	Minimum number of samples	Minimum frequency of control
<b>Initial inspection of the manufacturing plant and of factory production control</b>					
1	The notified factory production control certification body shall verify the ability of the manufacturer for a continuous and orderly manufacturing of the product according to the European Technical Assessment. In particular the following items shall be appropriately considered: - personnel and equipment - the suitability of the factory production control established by the manufacturer - full implementation of the prescribed test plan.				At the beginning of the contract between NB and Manufacturer
2	<u>Only in case of AVCP system 1:</u> See activity detailed at previous point 1 and add the verification of the contribution of the components to the performance in terms of Reaction to fire (see test with * in previous Table 7)	Presence of suitable test equipment Presence of trained personnel Presence of an appropriate quality assurance system and necessary stipulations			At the beginning of the contract between NB and Manufacturer
<b>Continuous surveillance, assessment and evaluation of factory production control</b>					
3	It shall be verified that the system of factory production control and the specified manufacturing process are maintained taking account of the control plan.				Once a year
4	<u>Only in case of AVCP system 1:</u> See activity detailed at previous point 1 and add the verification of the contribution of the components to the performance in terms of Reaction to fire (see test with * in previous Table 7)	Inspection of factory, of the production of the product and of the facilities for factory production control			Once a year
Evaluation of the documents concerning the factory production control			Once a year		
Issuing a report of surveillance			Once a year		

### 3.4 Special methods of control and testing used for the verification of constancy of performance

#### 3.4.1 Adhesives (except for foam adhesives), base coats, key coats and finishing coats

##### 3.4.1.1 Product as delivered

The following tests are performed on homogenised and unmodified products.

**Density**Pastes and liquids:

This is measured at  $(23 \pm 2)^\circ\text{C}$  in a  $100\text{ cm}^3$  or  $1000\text{ cm}^3$  cylinder.

Powders:

This is measured at  $(23 \pm 2)^\circ\text{C}$  in a  $500\text{ cm}^3$  cylinder.

Method of operation:

The results are recorded after maximum packing down on a vibrating table and levelling of the surface.

The results are expressed in  $\text{kg/m}^3$  (mean value of 3 tests).

**Dry extract (only pastes and liquids)**Lime and polymer based products

This is determined after placing the sample in a ventilated oven set at  $(105 \pm 5)^\circ\text{C}$  until a constant mass is obtained.

The mass is regarded as constant if the difference in mass between two successive weightings, one hour apart, does not exceed 0.1 g.

Initial weighing for testing:

- 2 g for liquid products (impression, etc ...),
- 5 g for products in paste form.

The results are expressed as a percentage relative to the initial mass (mean value of 3 tests).

Silicate based products

The dry extract is determined by the following method:

A - Initial weighing of approximately 5 g (product in the as-delivered state) on an aluminium sheet, approximately  $100\text{ mm} \times 100\text{ mm}$ , 2/3 covered.

B - Pre dry for 1 hour at  $(125 \pm 10)^\circ\text{C}$ .

Dry for 2 hours at  $(200 \pm 10)^\circ\text{C}$ .

C - Final weighing.

Weighing accuracy shall be within 5 mg.

The difference in mass from the initial weighing is accounted for by volatile components including water of crystallization.

The results are expressed as a percentage relative to the initial mass (mean value of 3 tests).

**Ash content**Pastes and liquids:

The ash content is determined on the same samples as those on which the dry extract has been measured.

Powders:

The ash content is determined at  $450^\circ\text{C}$  and  $900^\circ\text{C}$  on a sample of approximately 5 g pre-dried at  $(100 \pm 5)^\circ\text{C}$  or at  $(200 \pm 5)^\circ\text{C}$  for silicate based products, to constant mass. The mass is regarded as constant if the difference in mass between two successive weightings, one hour apart, does not exceed 0.1 g.

Method of operation:

- the sample is placed in a tared crucible either fitted with a lid or enclosed in a leak-tight container and the whole is weighed,

- after the lid has been removed, where necessary, the crucible is placed in the oven maintained at ambient temperature,

- the temperature of the oven is then raised to  $(450 \pm 20)^\circ\text{C}$  (ash content at  $450^\circ\text{C}$ ) or to  $(900 \pm 20)^\circ\text{C}$  (ash content at  $900^\circ\text{C}$ ) and maintained at that temperature for 5 hours,

- the crucible is allowed to cool down to room temperature in the desiccators before being weighed.

The results are expressed as a percentage relative to the initial mass after drying (mean value of 3 tests).

Note: The tolerances at  $900^\circ\text{C}$  may become larger, taking account of the products' composition.

**Particle size grading**Pastes:

Particle size grading is established from a sample of fillers removed from the manufactured product after washing on a sieve, mesh size 0.08 mm or after any other suitable and pertinent preparation.

The test is carried out after drying at least 105 °C.

Powders:

Particles size grading is established from a sample of fillers removed from the manufactured product.

Method of operation:

The test is performed using air stream sieving on an about 50 g specimen for 5 minutes per sieve. The curve is traced from 0.04 (for powders) or 0.08 (for pastes) to 4 mm with at least 5 intermediate sieves.

### 3.4.1.2 Fresh mortar

*Preparation of mortar:* the mortar is prepared in the laboratory using a concrete mixer (pan type) in accordance with EN 196-1. The tests are carried out immediately after mixing unless otherwise specified by the manufacturer (possible delay time necessary prior to application).

Dry mortar

- 2 kg of powder is poured into the container and the required amount of water as specified by the manufacturer is added,
- the whisk is turned manually a few times to clear the path of the mixer,
- the material is mixed for 30 seconds at low speed,
- the walls of the container are scraped and powder gathered on the whisk is detached with a spatula, if necessary,
- the material is mixed again for 1 minute at low speed.

Paste requiring addition of cement and powder requiring addition of extra binder

- For pastes, 1 litre of paste is poured into the container and the amount of cement prescribed by the manufacturer is added.
- For powder, 2 kg of powder is poured into the container and the amount of extra binder prescribed by the manufacturer is added.
- The whisk is turned manually a few times to clear the path of the mixer,
- the material is mixed for 30 seconds at low speed,
- the walls of the container are scraped and powder gathered on the whisk is detached with a spatula, if necessary,
- the material is mixed again for 3 minutes at high speed.

### 3.4.1.3 Ready to use paste

Pastes have to be homogenised before use.

***Water retention capability***

Water retention capability is determined for the fresh mortar, mixed as detailed in 3.4.1.2.

The test is performed using the apparatus described in the Standard ASTM C.91. The mortar is subjected to vacuum for 15 minutes as follows:

For base coat and finishing coat(s) (except coat(s) whose binder is pure polymeric), the vacuum applied is 50 mmHg (pressure difference between the exterior and the interior of the container).

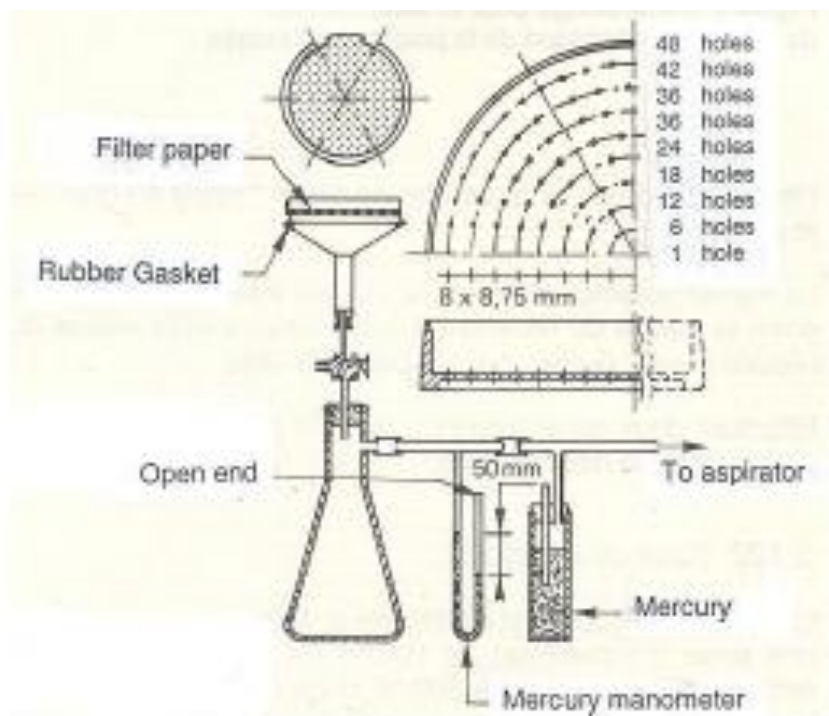

Fig. 19: Apparatus Assembly for the water retention test under 50 mmHg vacuum

For adhesives, the residual pressure is 60 mmHg (absolute pressure inside the container).

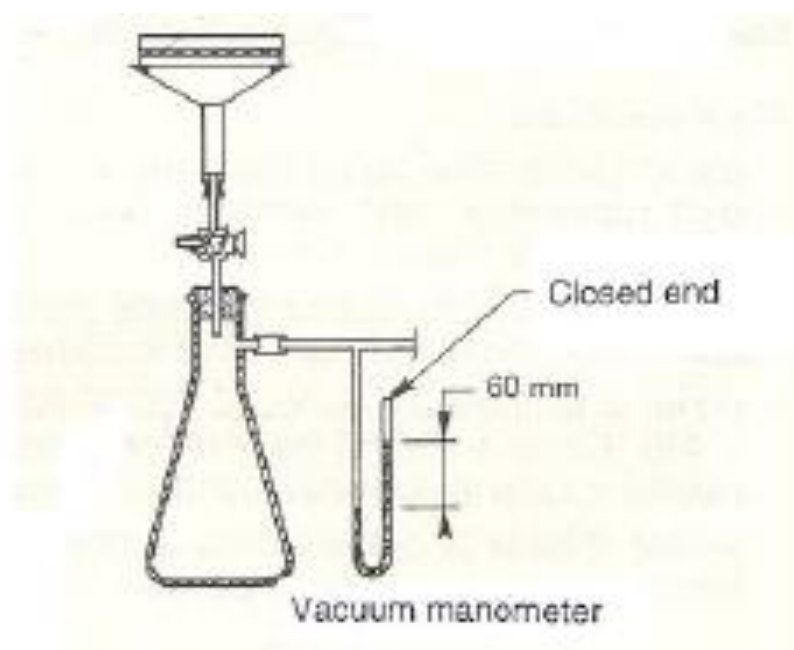

Fig. 20: Apparatus Assembly for the water retention test under 60 mmHg residual pressure

The dish is fitted with a filter paper (diameter 150 mm of 65 g/m<sup>2</sup>), previously moistened and drained by placing on a dry filter paper, filled with paste, levelled and weighed prior to the test (as the mass of the empty dish including the moist filter paper is known, the mass of the mixed paste and the corresponding mass of the water used for mixing can be calculated in g).

These operations take place within 10 minutes of mixing. After 15 minutes (from when mixing started) the apparatus is subjected to vacuum for 15 minutes; the dish is then weighed again after wiping off the undersurface, and the loss of water (e) in g can be calculated by subtraction.

The water retention capability is expressed as a % of the initial mass of the water used for mixing (E):

$$\frac{E - e}{E} \times 100$$

### **Density of fresh mortar**

The mortar is prepared as detailed in 3.4.1.2.

The apparent density is determined using a 1 litre cylindrical container, previously tared (mass  $M_0$  in g). The container is filled with paste and after compacting down, wiped off and weighed (mass  $M_1$  in g). The density of the paste (in  $\text{kg}\cdot\text{m}^{-3}$ ) is equal to  $M_1 - M_0$ .

The density of the paste is measured immediately after mixing.

## **3.4.2 Foam adhesive**

### **Density**

#### Tools:

- PE-foil
- Sharp and clean knife (cutting knife)
- Balance with an accuracy of 0.1 g
- Measuring cylinder with an increment of 10 ml
- Water.

#### Preparation of test samples:

A full bottle/can shall be used for preparation of test samples. The bottle/can is shaken at least 20 times before application. The first approximately 100 g of foam is discarded by spraying.

Cylindrically shaped beads with diameter of 20 to 30 mm and about 200 mm length are sprayed on a PEfoil from a distance of approximately 10 mm and left to harden.

After 24 hours minimum, the beads shall be cut on both sides to a length of 100 to 150 mm.

#### Test procedure:

The mass of the samples is measured in grams ( $m$ ) with an accuracy of 0.1 g.

A measuring cylinder having an increment of 10 ml is filled with water and a reference volume ( $V_0$ ) is set. By pressing a cutting knife into one end of the bead, the sample is submerged into the measuring cylinder. The increased volume ( $V_1$ ) is read off immediately.

#### Calculation:

The density of the PUR-Foam is determined by using the following formula:

$$\rho = \frac{m}{V_1 - V_0} * 1000$$

The results shall be expressed in  $\text{kg}/\text{m}^3$ .

The test result shall be calculated as the mean of at least 5 single values.

### **Tack Free Time**

#### Background and purpose:

The tack free time is the time after which a bead of foam has formed a skin, so that adhesion on the surface has stopped. The tack free time is susceptible to temperature and humidity conditions. It is usually prolonged by lower temperature and / or lower humidity.

#### Tools:

- Paper or cardboard
- Small rod or tube made of PE (e.g. straw)
- Clock or stopwatch.

#### Test procedure:

Cylindrically shaped beads with diameter of 20 to 30 mm are sprayed on the cardboard and the time is noted ( $t_0$ ) or the stopwatch is started. The surface of the bead is touched gently with the small rod/tube (without penetrating the skin) several times after applying the foam, e.g. every 30 sec (see Figure 21). For



every touch a clean part of the rod/tube and a new spot on the bead shall be used. The time when no foam adheres to the rod is noted ( $t_1$ ).



Fig. 21: Touching the bead with the rod/tube

#### Calculation:

$$t_{\text{tack free}} = t_1 - t_0$$

No calculation is needed when using a stopwatch. The result is expressed in minutes (min).

#### **Cutting Time**

##### Background and purpose:

The cutting time is the time after which cut surface of a cylindrically shaped bead of (not entirely hardened) foam, 30 mm in diameter, is not sticky anymore, the knife remains clean without pre-polymer residues and the cells are not squeezed.. It is a time after which the foam is not entirely hardened, but it can be processed. The foam hardening process is usually prolonged by lower temperature and/or lower humidity.

##### Tools:

- Sharp and clean knife (cutting knife)
- Paper or cardboard
- Clock or stopwatch
- Template with a window of 30 mm height and approximately 60 mm width. See Figure 22.

##### Test procedure:

Cylindrically shaped beads with diameter of 20 to 30 mm are sprayed on the cardboard (see Figure 23) and the time is noted ( $t_0$ ) or the stopwatch is started. Measurements shall be started 10 minutes before the anticipated cutting time.

To check the bead diameter the template according to Figure 24 is used.

The bead is cut in a place with 30 mm diameter, found by template (see Figure 3). The bead shall not be "sawn", but cut in one or two steps at a fast pace.

If fresh polymer remains on the knife, the foam cells are crushed or the cut surface is still sticky, the foam is still not cured. Another bead or part of bead is cut in the same way after 3 minutes. It shall be ensured that no impact on the foam due to a previous cut surface occurs.

This procedure is repeated every 3 minutes (respectively 1 minute when being close to the anticipated cutting time) until the foam cells are not squeezed by the knife and the cut surface is not sticky. Also the bead shall stay in shape.

The time is noted ( $t_1$ ).

#### Calculation:

$$t_{\text{cutting}} = t_1 - t_0$$

No calculation is needed when using a stopwatch.  
The result is expressed in minutes (min).

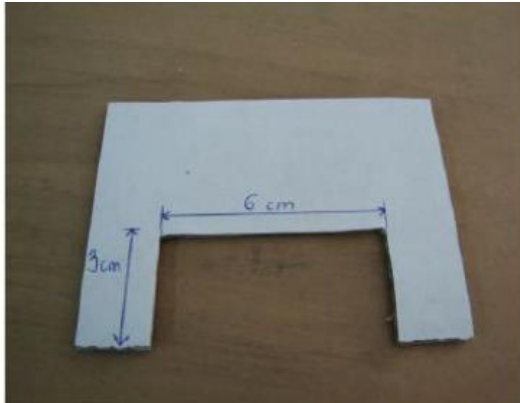

Fig. 22: Template



Fig. 23: Beads on the cardboard



Fig. 24: How to find 3 cm diameter bead

### 3.4.3 Insulation product

#### 3.4.3.1 Density measurement

In accordance with EN 1602.

#### 3.4.3.2 Dimensional characteristics and appearance

##### *Length and width*

In accordance with EN 822.

##### *Thickness*

In accordance with EN 823.

##### *Squareness*

In accordance with EN 824.

##### *Flatness*

In accordance with EN 825.

*Surface condition*

This is visually assessed.

**3.4.3.3 Compression test**

In accordance with EN 826. This test is not necessary for EPS insulation.

**3.4.3.4 Dimensional stability tests**

In accordance with:

- EN 1603;
- EN 1604 (conditionings specified in the relevant product standard).

**3.4.4 Reinforcement****3.4.4.1 Mass per unit area**

The mass per unit area is determined by measuring and weighing a one metre length of mesh. For reinforcement in roll form, the width of the sample should be the same as the roll width. The result is expressed in g/m<sup>2</sup>.

**3.4.4.2 Ash content**

This test applies to glass fibre mesh only.

The ash content is determined at (625 ± 20)°C on three 100 mm square samples, cut parallel to the yarn and at least 100 mm apart from the side to constant mass.

The result is expressed as a percentage relative to the initial mass.

**3.4.4.3 Mesh size and number of filaments**

The mesh size is determined by measuring the distance between 21 yarns (e.g. 20 mesh) in warp and in weft direction.

The mesh opening is calculated by subtracting the thickness of the yarn from the mesh size.

**3.4.4.4 Elongation**

See 2.2.3.23, 2.2.3.24 and 2.2.3.25.

**3.4.5 Mechanical fixing devices****3.4.5.1 Load characteristics if necessary (depending on the type of material)**

The result shall be stated in the accompanying documents.

#### 4. REFERENCE DOCUMENTS

As far as no edition date is given in the list of standards thereafter, the standard in its current version at the time of issuing the European Technical Assessment, is of relevance.

ETAG 007	Timber frame building kits
EOTA TR 001	Determination of impact resistance of panels and panel assemblies
EOTA TR 021	Reaction to fire requirements for small components
EN 13986	Wood-based panels for use in construction - Characteristics, evaluation of conformity and marking
EN 13162	Thermal insulation products for buildings - Factory made mineral wool (MW) products - Specification+A1:2015
EN 13163	Thermal insulation products for buildings - Factory made expanded polystyrene (EPS) products - Specification
EN 13164	Insulation products for buildings - Factory made extruded polystyrene (XPS) products - Specification
EN 13165	Thermal insulation products for buildings - Factory made polyurethane foam (PUR) products - Specification
EN 13168	Thermal insulation products for buildings - Factory made wood wool (WW) products - Specification
EN 13171	Thermal insulation products for buildings - Factory made wood fibre (WF)products - Specification
EN 1995-1-1	Eurocode 5; design of timber structures; part 1- 1: general rules and rules for buildings
EN 380	Timber structures; test methods; general principles for static load testing
EN 594	Timber structures - Test methods - Racking strength and stiffness of timber frame wall panels
EN 595	Timber structures - Test methods - Test of trusses for the determination of strength and deformation behaviour
EN 596	Timber structures - Test methods - Soft body impact test of timber framed walls
EN 13238	Reaction to fire tests for building products - Conditioning procedures and general rules for selection of substrates
EN 12089	Thermal insulating products for building applications - Determination of bending behaviour
EN 1382	Timber structures - Test methods - Withdrawal capacity of timber fasteners
EN 28970	Timber structures; testing of joints made with mechanical fasteners; requirements for wood density
EN ISO 13788	Hygrothermal performance of building components and building elements - Internal surface temperature to avoid critical surface humidity and interstitial condensation - Calculation method (ISO 13788:2001)
EN 12114	Thermal performances of buildings - Air permeability of building components and building elements - Laboratory test method

EN 312	Particleboards – Specification
EN 322	Wood-based panels; determination of moisture content
EN 622-2	Fibreboards - Specifications - Part 2: Requirements for hardboards
EN 622-3	Fibreboards - Specifications - Part 3: Requirements for medium boards
EN 622-5	Fibreboards - Specifications - Part 5: Requirements for dry process boards (MDF)
EN 300	Oriented Strand Boards (OSB) - Definitions, classification and specifications
EN 636	Plywood – Specifications
EN 13353	Solid wood panels (SWP) – Requirements
EN 634-2	Cement-bonded particleboards - Specifications - Part 2: Requirements for OPC bonded particleboards for use in dry, humid and exterior conditions
EN 520	Gypsum plasterboards - Definitions, requirements and test methods
EN ISO 7823-1	Plastics - Poly(methyl methacrylate) sheets - Types, dimensions and characteristics - Part 1: Cast sheets (ISO 7823-1:2003)
EN ISO 7823-2	Plastics - Poly(methyl methacrylate) sheets - Types, dimensions and characteristics - Part 2: Extruded sheets (ISO 7823-2:2003)
EN ISO 7823-3	Plastics - Poly(methyl methacrylate) sheets - Types, dimensions and characteristics - Part 3: Continuous cast sheets (ISO 7823-3:2007)

## ANNEX A REACTION TO FIRE TESTING OF ETICS WITH RENDERING FOR THE USE ON TIMBER FRAME BUILDINGS

### 1. GENERAL

This Annex deals with ETICS with the following insulation materials: EPS (hEN 13163), XPS (hEN 13164), PU (hEN 13165), PF (hEN 13166), ICB (hEN 13170), MW (hEN 13162), WW (hEN 13168) and WF (hEN 13171).

ETICS consisting of other insulation material are not covered and are to be tested to separate arrangements.

The ETICS is either fixed to an external board (wood based panels, solid wood panels, cement bonded boards, fibre-cement panels, plasterboards, gypsum bonded boards, fibre-gypsum panels, and similar products), or directly to a timber frame construction. In the latter case it is assumed that the infill areas in the timber frame are filled with mineral wool insulation material. Other types of construction are to be tested to separate arrangements.

In any case the reference can be made to EN 15725 for extended applications.

#### **Principle**

The determination of reaction to fire of the ETICS is based on testing of “the worst case” - the most critical configuration in sense of reaction to fire. According to the rules described further in the text, the classification obtained on the most critical ETICS configuration is valid for all configurations having better performance in sense of reaction to fire.

For the particular types of ETICS components the following principles apply:

- the base coat and finishing coat with the highest amount of organic content (related to the mass in dried condition as in end use application) or the highest PCS value (according to EN ISO 1716)<sup>7</sup> shall be used for preparing the specimen,
- each decorative coat and key coat shall be tested unless it can be neglected according to the rules below. If there are only differences in the amount of organic content but no difference in the organic component itself, the decorative coat and the key coat with the highest organic content or the highest PCS value (according to EN ISO 1716)<sup>6</sup> of this organic component shall be tested,
- the decorative coat and/or the key coat can be neglected as long as they comply with the following<sup>8</sup>:
  - the thickness of the decorative coat is less than 200 µm
  - and the content of organic components is of not more than 5% (related to the mass in dried condition as in end use application).

In addition, each coat selected for testing according to the rules above before shall have the lowest amount of flame retardants.

#### **Product properties influencing the reaction to fire behaviour**

- Type of insulation product (composition, thickness, density)
- Type of base coat and finishing coats (composition, thickness, weight per unit area)
- Type of key coats and decorative coats (composition, weight per unit area)
- Type of reinforcement (composition, thickness, weight per unit area)
- Type and nature of fixings
- Type and nature of fire breaks (interruptions to the continuity of insulation or any cavity)<sup>9</sup>

<sup>7</sup> The Manufacturer is responsible for the information on organic content per unit area. If the information is not available, the PCS value is tested to decide about the worst case.

<sup>8</sup> This rule can be reconsidered when more experience and test result are available

<sup>9</sup> Fire breaks are important for the behaviour of the whole façade cladding system and cannot be assessed on the basis of SBI-testing. The influence can only be observed during a large scale test. Therefore breaks are not included in the mounting and fixing rules for the SBI-test. An European fire scenario for façades has not been laid down. An additional assessment according to national provisions (e.g. on the basis of examining design solutions or a large scale test) might be necessary to comply with Member State regulations, until the existing European classification system has been completed.

- The organic content of the binder and of any organic additive; this can be checked by providing the formulation of the component, by performing suitable identification tests or by determining the glow loss or net calorific value.
- Type and amount of flame retardant intended to maintain or improve the reaction to fire performance of the ETICS or its components and consequently of building elements to which they are applied.
- Type and nature of substrate.

Although the rest of this annex applies the “worst case scenario” for deciding what to test, it is accepted that, where the Manufacturer produces a range of ETICS having different overall classifications, he may group these together into a number of different sub-groups (e.g. each sub-group corresponding to a different overall classification) with the ‘worst case scenario’ being identified for each sub-group.

Components of an ETICS, where these require separate assessment (as opposed to being tested as part of the ETICS as a whole), which are classified A1 without testing according to Decision 1996/603/EC, as amended, do not need to be tested.

## **2. TESTING ACCORDING TO EN ISO 1182**

This test method is relevant for the classes A1 and A2.

Using this test method, only the ‘substantial components’ of the ETICS need to be tested. ‘Substantial components’ are defined by thickness ( $\geq 1$  mm) and/or weight per unit area ( $\geq 1$  kg/m<sup>2</sup>).

In the following, the insulation product, the base coat and the finishing coat are identified as the most significant ‘substantial components’, but the adhesive, the key coat, the decorative coat and any reinforcement may also be ‘substantial components’.

Parameters relevant for this test method are:

- composition
- density.

### **2.1 Insulation product**

For ETICS expected to be classified as A1 or A2, it is anticipated that only insulation products with reaction to fire class A1 or A2 will form the insulation layer. For testing the insulation product reference should be made to the relevant product standards and to EN 15715.

### **2.2 Render coatings**

#### **2.2.1 Base coats and finishing coats**

Base coats and finishing coats in accordance with the provisions of EC Decision 1996/603/EC (as amended) are considered to satisfy the requirements for performance Class A1 of the characteristic reaction to fire without the need for testing.

The reaction to fire behaviour of base coats and finishing coats not falling under EC Decision 96/603/EC (as amended) shall be tested according to the principle specified in clause “General”.

The test result can be directly applied to all variants with the same base coat and finishing coat and with a lower amount of organic components. When the subject of the directly applied result contains a flame retardant, it shall be of the same type and its content must be at least that of the product tested.

Differences concerning the density shall be considered by testing the lowest and the highest density.

#### **2.2.2 Key coats and decorative coats**

The principles specified in clause 1 “Principle” shall be applied.

### 2.3 Adhesive

The same rules as given in 2.2 above should be applied. If the adhesive is identical to the tested base coat, the adhesive does not need to be tested separately.

### 2.4 Reinforcement

Each type of reinforcement that fulfils the requirements of a 'substantial component' shall be tested according to EN ISO 1182. For reinforcement that is randomly dispersed (e.g. fibres) in the render then it shall be tested as part of the render.

## 3. TESTING ACCORDING TO EN ISO 1716

This test method is relevant for the classes A1 and A2.

This test method shall be performed to all components of the ETICS except for cases which are classified as A1 without testing, according to Decision 1996/603/EC (as amended).

Parameters relevant for this test method are: composition (when performing calculation of the PCS<sub>s</sub>-value, density or weight per unit area and thickness are relevant). Mechanical fixings and ancillary materials which are not continuous but discrete components of ETICS shall not to be considered for testing and for the calculation of the PCS<sub>s</sub>.

### 3.1. Insulation product

For testing the insulation product, reference should be made to the relevant product standards and to EN 15715.

It is not realistic to require that each insulation product of the same type is tested within the classification of an ETICS. If the insulation products come from different manufacturers and/or are of different thickness, density and formulation from those used in the testing, these may be used subject to the requirements of class A1 and A2 still being fulfilled. It shall be proved by calculation (undertaken by an Assessment Body or Notified Body) that the ETICS, together with the actual mineral wool used in end use application, still fulfils the requirements concerning the PCS-value of the whole product. For example, it is sufficient to determine the PCS-value of the mineral wool and if this is lower than the originally tested product then it is acceptable to use the alternative mineral wool instead of that of used in the original test.

**Note:** Information relating to alternative insulation products of the same type to that originally tested may be evaluated on the basis of the supplier's evidence provided within the context of its CE marking.

### 3.2. Render coating

In general, when performing calculations of the unit area referred PCS<sub>s</sub>-value (related to the surface) the variant that provides the highest PCS<sub>s</sub>-value shall be considered.

The test shall be performed in accordance with the principles specified in § General applied to each component of the render coating.

The test results can be directly applied to all variants with the same render coating but with a lower amount of organic components. When the subject of the directly applied result contains a flame retardant, it shall be of the same type and its content shall be at least that of the product tested.

### 3.3 Adhesive

For the component adhesive of the ETICS, each product with a different formulation shall be tested for reaction to fire behaviour by selecting the variant with the highest amount of organic components. The test results can be directly applied to all variants with the same composition but lower amount of organic components. For the case where one of the render coatings is used as the adhesive, the rules according to chapter 3.2 shall be applied.

If the adhesive is identical to the tested base coat, the adhesive does not need to be tested separately.



### 3.4. Reinforcement

Each type of reinforcement shall be tested according to EN ISO 1716. For reinforcement that is randomly dispersed (e.g. fibres) in the render, then it shall be tested as part of the render.

## 4. TESTING ACCORDING TO EN 13823 (SBI-TEST)

This test method is relevant for the classes A2, B, C and D (in some cases also for A1<sup>10</sup>).

In this test procedure the complete ETICS shall be tested. The ETICS is fixed to a substrate representing that on which the ETICS is fixed in the end use application (reference is made to EN 13238). The fixing shall be made using either the adhesive used in the end use application or, in the case of purely mechanical fixing, by using the means of mechanical fixing used in the end use application. When adhesives are used, the test result is valid also for mechanical fixings.

When a purely mechanical fixing with plastic anchors is used the test result is valid also for metallic anchors. It is suggested that the specimens are assembled on to an EN 13823 test trolley directly, since the completed specimens may be extremely heavy and there is the potential for cracking of the rendering system during movement.

The maximum testable thickness of the test specimen, including a standard substrate according to EN 13238, is 200 mm. However, in practice, for many ETICS, the total overall thickness may be greater than 200 mm. In such cases, using a standard substrate, the thickness of the insulation product must be reduced to provide for the maximum specimen thickness of 200 mm. Results obtained on an ETICS at 200 mm thickness are accepted for greater thicknesses.

The test specimen consists of a corner construction using the ancillary materials in the corner that are used also in the end use application. All edges are covered with the rendering system excluding the bottom edge and the top of the specimen. See Figure 25. After preparation of the test specimens they shall be conditioned according to EN 13238.

#### Parameters which are relevant:

- amount of adhesive
- type, thickness and density of insulation product
- type, binder and thickness of each coat of render coating
- amount of organic content of each coat of render coating
- amount of flame retardant of each coat of render coating
- type of reinforcement
- type and nature of substrate.

In principle, it is desirable to find the test specimen configuration that gives the worst case concerning the reaction to fire test results. In the test procedure according to EN 13823, values for the rate of heat release, total heat release, lateral flame spread, rate of smoke release, total smoke release and burning droplets are determined. Due to the possible effects of the insulation product, the following proposals are divided by considering separately the testing of ETICS with class A1 and A2 insulation products and the testing of ETICS with class B, C, D and E insulation products.

### 4.1 Substrate and faces exposed to flame attack

For the substrates distinction shall be made between ETICS being fixed to:

- a) external boards as: wood based panels, solid wood panels, cement bonded boards, fibre-cement panels, plasterboards, gypsum bonded boards, fibre-gypsum panels, and similar products;
- b) timber frames.

Both cases are to be assessed separately.

---

<sup>10</sup> In cases according to EC Decision 2000/147/EC, Table 1, Footnote 2a; A1 case mentioned in EN 13501-1 does not apply to ETICS

For ETICS construction of type "a)" an appropriate standard substrate board according to EN 13238 shall be used for preparing the ETICS specimens taking into account the relevant substrates in end-use applications.

Only the outer face of the ETICS shall be exposed to flame attack.

If an ETICS is mounted directly onto timber frames (construction type (b)) it cannot be considered as an additional layer on the outside of an existing wall, but it forms an integral part of the wall itself. In such case an exposure to flame attack of the unprotected backside of the ETICS can not be ruled out. Since an ETICS is a non-homogenous product having an asymmetric assembly, it has to be tested on both sides for the application on a timber frame. The outer as well as the inner face shall be exposed to flame attack.

For testing the outer face the ETICS shall be mounted on a timber framing as described below:

- non FR-treated spruce wood of standard grade, saw-cut, with a density of not less than 350 kg/m<sup>3</sup>
- horizontal and vertical members of (30±1) mm depth x (50±1) mm width, one at either side of each wing (top, bottom, left and right) and additional horizontal members at distances not greater than 500 mm, or as per the end-use situation.
- 

The infill between the timber members is to be filled with mineral fibre insulation according to EN 13238.

For testing the inner face freestanding specimens of the ETICS shall be used, but only with a distance of 40 mm between specimen and backing board of the SBI apparatus.

Other constructions with other substrates not defined above have to be assessed in separate tests to their end-use conditions.

## 4.2 Insulation product

In general the following rules shall apply regarding the relevant insulation thickness dependent from the standard substrate board used for preparing the test specimens:

- In case of using a standard substrate board of reaction to fire class A1 or A2 only the highest thickness of the insulation product shall be used for preparing the test specimens.
- In case of using a standard substrate with a reaction to fire class different from the above mentioned case, ETICS specimens with the highest and lowest thickness of the insulation product shall be tested.
- In case of testing an ETICS which is mounted onto the substrate by using an adhesive (only bonded or mechanically fixed and bonded) with organic content of more than 15% (related to the mass in dried condition) always specimens with the highest and lowest thickness of the insulation product shall be tested (independent from the reaction to fire class of the standard substrate).

For testing ETICS with insulation products of reaction to fire class A1 or A2 the insulation product with the highest and lowest density as well as the highest organic content (related to the mass in dried condition) has to be used for preparing the test specimens. The reaction to fire class A1 or A2 of the insulation product shall be proven separately (for that reference should be made to the relevant product standard and EN 15715).

For testing of ETICS with insulation products made of polystyrene (PS) or polyurethane (PU) both with reaction to fire class B, C, D or E, each type of the insulation product (PS, PU plus taking into regard the reaction to fire class of the insulation product) shall be tested within the system. For each type of insulation product the insulation product with the highest and the lowest density shall be used for preparing the test specimens.

For testing ETICS with insulation products made of phenolic resin (PF) or wood fibre (WF) each insulation product with the highest and lowest density shall be used for preparing the test specimens.

For testing ETICS with insulation products made of expanded cork (ICB) or wood wool (WW) EN 15725 shall be used as orientation to define all specimen configurations being relevant for testing and taking into account the intended field of application of the test results.

### 4.3 Render coatings

By testing one specific render coating representing a range of different coats, the following rules shall be applied to discriminate the composition, which is able to represent a range of coats:

- The base coat, the key coat, the finishing coat and the decorative coat to be used for preparing the specimen, taking account of the permissible combination(s) allowed by the manufacturer, shall be determined in accordance with the principles specified in clause 1 “General”.
- For a base coat and a finishing coat having an organic content less than or equal to 5% (related to the mass in dried condition as used in the end use application), only the lowest thickness need be used for preparing the test specimen.
- For a base coat or a finishing coat having an organic content higher than 5%, both the lowest and the highest thickness of the layer of the base coat and finishing coat shall be used for preparing the test specimens.

When the only difference in coatings is thickness and it is 0.5 mm or less, the coatings may be considered to be the same.

Note: As long as the base coat and finishing coat with highest organic content is accepted by the Manufacturer to be representative for all, the SBI-test with the inorganic coats is not obligatory.

### 4.4 Adhesive

The influence of the type of adhesive having an organic content of equal or less than 15% (related to the mass in dry condition) is assumed to be negligible. Only the amount of organic content is considered important. Therefore, an adhesive with the highest amount of organic content should be used for preparing the test specimens applied at the maximum thickness.

The influence of adhesives having an organic content of more than 15 % can not be assumed to be negligible. Therefore, each type of adhesive with a different composition shall be tested by selecting the variant with the highest organic content.

### 4.5 Reinforcement

The specimens shall be prepared with the reinforcement that is intended to be used in end use application. If different reinforcements are intended to be used, the reinforcement with the highest PCS<sub>S</sub>-value per unit area and the lowest weight per unit area shall be used for preparing the SBI specimen. At the long wing of the SBI specimens a vertical joint of the reinforcement shall be considered at a distance of 200 mm away from the inner corner of the specimens by 100 mm overlapping of the two layers of the reinforcement (that means the joint begins at a distance of 150 mm and ends at a distance of 250 mm away from the inner corner).

### 4.6 Application of test results

The test result covers arrangements with insulation products of the same type, with thicknesses and densities between those evaluated in tests and with equal or lower organic content.

The test result is valid for:

- insulation products:
  - of the same type,
  - with thickness and densities between those evaluated in the tests,
  - with equal or less organic content,
- base coats and finishing coats:
  - with equal or less organic content,
  - with equal or greater content of the same type of flame retardants,
  - with equal or greater thickness if the organic content is equal to or less than 5 %,
  - with thickness between those evaluated in the test if the organic content is higher than 5%.
- key coats:
  - with equal or less organic content,

- with equal or greater content of the same type of flame retardants,
- decorative coats:
  - with equal or less organic content per unit area,
- adhesives:
  - with equal or less organic content and equal or less thickness if the organic content is equal to or less than 15%,
  - of the same type, with equal or less organic content and equal or less thickness if the organic content is greater than 15%,
- reinforcements:
  - with an equal or less PCS<sub>S</sub>-value per unit area
  - with equal or higher weight per unit area.

For ETICS being fixed to a standard substrate board according to EN 13238 the test results are valid for the use on all substrates covered by the standard substrates board used in the tests in accordance with the provisions given in EN 13238.

In the case of ETICS being fixed to a wood based panel, EN 13238 is the reference for the extension of the results to other substrates.

Test results of ETICS being fixed to a timber framing and with mineral wool insulation between the members of the framing are valid for:

- framings made of timber of reaction to fire class of at least D-s2,d0 with a density equal to or greater than 350 kg/m<sup>3</sup> or metal framings and
- mineral wool insulation in the spacing of the framings having a reaction to fire class A1 or A2 and a density equal to or greater than the density of the standard substrate as used for testing.

## 5. TESTING ACCORDING TO EN ISO 11925-2

This test method is relevant for the classes B, C, D and E.

In this test procedure, the ETICS is tested without using a substrate. The maximum thickness of the test specimen is 60 mm. In cases where the thickness of the ETICS is larger than 60 mm, the insulation product may be reduced for the purposes of testing. The results from the testing of specimens at 60 mm are applicable to greater thicknesses.

### Parameters which are relevant:

- type and amount of adhesive,
- type, thickness and density of insulation product
- type, binder and thickness of each coat of render coating
- amount of organic content of each coat of render coating
- amount of flame retardant of each coat of render coating
- type of reinforcement.

The specimens are prepared in such way that the edges are not covered with the rendering system (cut edges). The tests are performed with surface flaming of the front side and edge flaming of the test specimen turned by 90° according to the rules of standard EN ISO 11925-2.

### 5.1 Insulation product

It is proposed to use an intended insulation product, representative in its characterisation (type, reaction to fire classification and density) for the end use application. The ETICS shall be evaluated incorporating the insulation product at the highest possible thickness and the highest and the lowest possible densities.

For ETICS with insulation products made of polystyrene or polyurethane (PUR) classified class E<sup>11</sup>, the test results are valid only for the insulation products as used in the test. Manufacturers have the possibility of using insulation products from different manufacturers when the following additional tests are performed

---

<sup>11</sup> For the application of the ETICS e.g. in Germany the insulation product alone must be classified at least class E

and conditions are fulfilled or the manufacturer provides the necessary evidence. For insulation products made of polystyrene or PUR, it shall be proven separately that the product fulfils the requirements for reaction to fire class E under the following conditions or the manufacturer provides the necessary evidence. Polystyrene insulation has to be tested with the highest density and at a thickness of 10 mm for expanded polystyrene foam and at the minimum thickness produced for extruded polystyrene. The test result is valid for lower densities and higher thicknesses. PUR insulation shall be tested at the density intended for the end use and at the highest thickness. The test result is valid for PUR insulation with the same density and for lower thicknesses.

## 5.2 Render coatings

For testing one specific rendering system representing a range of different coats, the rules as mentioned in 4.2 apply.

## 5.3 Adhesive

For adhesives (mortars) having an organic content of equal or lower than 15 % (related to the mass in dried condition) it can be assumed that they fulfil the requirements of the classes B to E within testing according to EN ISO 11925-2. Therefore, no need exists to take into account such adhesives for preparing and testing specimens of ETICS according to this standard.

For adhesives having an organic content of more than 15% (related to the mass in dried condition) it is necessary to carry out a complete set of six additional tests on specimens turned at 90 degrees on their vertical axis with edge exposure of the adhesive layer. The specimens consist of the substrate, the adhesive and the insulation product. The following rules shall be applied for preparing the specimens:

- each type of adhesive with a different composition shall be used by selecting the variant with the highest amount of organic content and with the highest thickness,
- the insulation product shall be used with the lowest thickness applied for the assessment.

The substrate must be the same as the one used for SBI testing of the ETICS as a whole.

## 5.4 Reinforcement

The specimen shall be prepared with the reinforcement intended to be used in end use application. If different reinforcements are intended to be used, the reinforcement with the highest PCS<sub>S</sub>-value per unit area and the lowest weight per unit area have to be tested.

## 5.5 Application of test results

The test result covers end use application arrangements with the same type of insulation product (excluding insulation made of polystyrene or PUR) as used in the tests with thicknesses and densities between those evaluated in tests and equal or lower organic content.

The test results from tests with insulation products made of polystyrene or PUR classified class E are valid for ETICS with insulation products as used in the test or for ETICS with any polystyrene and PUR insulation products classified class E when the test evidence according to 5.1 was provided.

For insulation products made from wood fibre or wood wool, the test results are only applicable to insulation products of the same type with the same or a better reaction to fire class as of the product tested (minimum requirement class E).

For the extended application of test results regarding base coat, key coat, finishing coat, decorative coat, reinforcement and adhesive the same rules shall apply as given in 4.6.

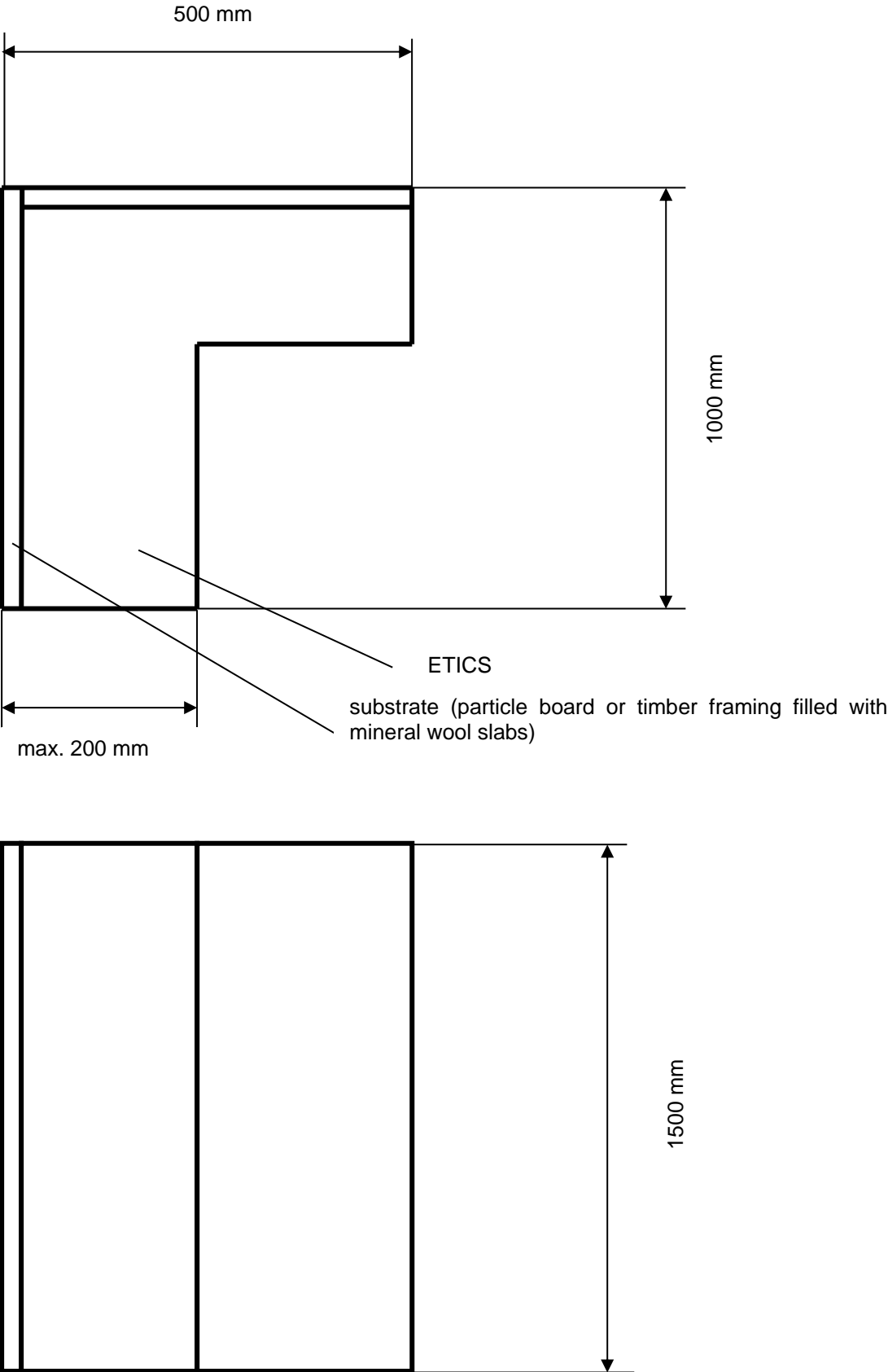
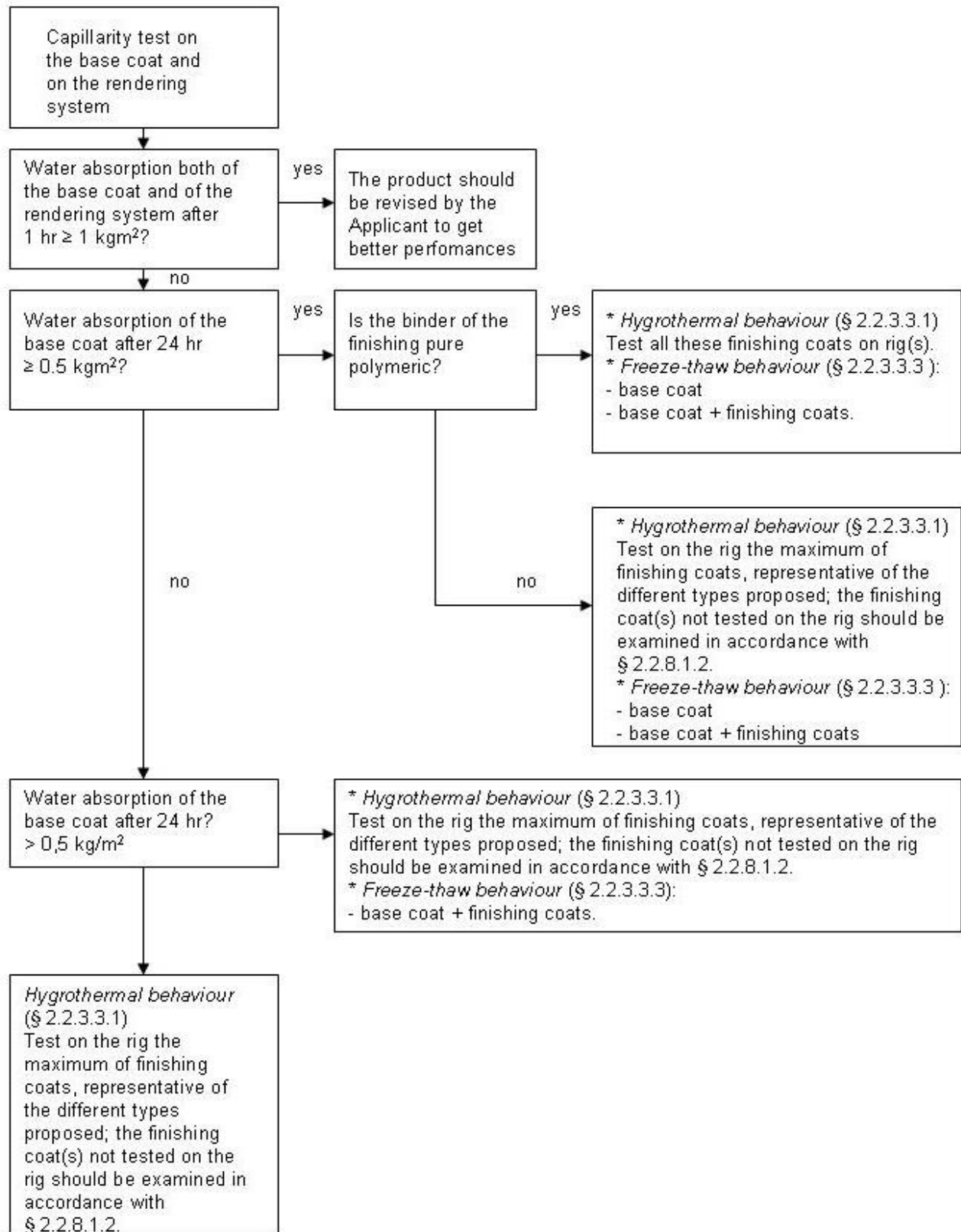

Fig. 25: Schematic drawing of the test specimen in the SBI-test according to EN 13823

Remark: This proposed test specimen arrangement is not in accordance with the standard due to the extended substrate of the small specimen wing, but is supposed to represent better the end use application.

## ANNEX B RECOMMENDATIONS FOR CHOOSING THE TESTS TO BE PERFORMED IN ORDER TO ASSESS THE WATER TIGHTNESS OF THE ETICS



## ANNEX C ANALYSIS OF SIMULATED DRIVEN RAIN TEST RESULTS

In order to address the queries concerning external wall constructions clad with this type of system a weighted method similar to a Failure Mode and Effects Criticality Assessment (FMECA) approach has been developed. This relates each tested system to the general suitability for use in a particular exposure zone, for example an insulation board applied directly to an untreated timber frame would have a high weighting, whereas a system incorporating methods for managing water ingress, such as drained cavities and breather membranes would have less of a weighting.

The results of the driven rain test should be considered with relation to Table A below. A factor relating to the measures against water ingress should be taken from Table B, a factor concerning the level of site supervision should be taken from Table C, and a factor concerning the likelihood of the installed system being regularly maintained from Table D.

### Test result grading<sup>12</sup>

Table A

Test result	Driven rain grade ( $D_{r \text{ test}}$ )
Suitable for use in sheltered areas	1
Suitable for use in moderate areas	2
Suitable for use in severe areas	4

### The weighting assigned to the specific details of a system

Table B

Detail	Detail factor ( $D_f$ )
Cavity, breather membrane, water management system ensuring any water ingress is directed outwards	2
Cavity and breather membrane	5
No second line of defence against water ingress	10

### Installation factor

A site installation check list should cover the following points:

Installation stage	Check point
Overall construction	Have the appropriate details been used?
	Have the correct materials been used?
Stage 1 Preliminary work	Has the appropriate preliminary work been carried out as detailed in the Assessment? for example, have the following been used in accordance with the Assessment: - profiles (type and layout) - sealant(type and application) - beading (type and layout) - proprietary seals (type and application)
Stage 2 Installation of insulation	Has the insulation been installed as detailed in the Assessment? for example, have the following been completed as detailed in the Assessment: general layout of insulation boards layout of insulation boards around openings and penetrations general condition of any drainage cavity formed within the system fixings
Stage 3 Application of basecoat	Are the appropriate materials and seals being used as detailed in the Assessment for example, have the following been completed as detailed in the Assessment: Application of seals around openings beading (type and layout) detailing around openings and penetrations

<sup>12</sup> For example this rating could result in a change from Severe to Moderate exposure zones



Table C

checklist followed	Installation factor ( $I_f$ )
Yes	1
No	10

### Maintenance factor

This assessment method is based upon the assumption that appropriate regular maintenance is carried out and that any problems associated with water ingress are readily identifiable and corrected as soon as they are noted.

Appropriate maintenance relates to yearly inspections and makes the assumption that repairs are conducted as soon as a problem is noted. In severe locations increased levels of maintenance may be required. This would typically require 2 or more inspection visits per year and should include an assessment of moisture levels within the structure. As noted previously it is expected that any maintenance required is carried out as soon as the requirement is noted. Many systems of this type rely on sealants for weatherproofing, the sealant should be inspected and replaced at regular intervals to ensure it remains effective.

The increased inspection visits may offset the risk of water penetration by highlighting problems before they cause substantial damage to the construction. Techniques such as thermography (the use of an IR sensitive camera to detect temperature differentiation associated with damp areas) could be used to expose the presence of water within a construction.

Table D

Maintenance possible	Maintenance factor ( $M_f$ )
Yes	1
No	100

Each of the factors should be combined using the following method to give an overall rating for the system which can be used to give preliminary guidance concerning the suitability for use of a particular system in a particular exposure zone.

$$\text{Overall rating} = D_{r \text{ test}} \cdot D_f \cdot I_f \cdot M_f$$

The overall rating should be compared to the values listed in Table 2 for an idea of the suitability for use in a particular exposure zone. Worked examples can be seen below.

Description	$D_{r \text{ test}}$	$D_f$	$I_f$	Overall rating	Maintenance $M_f$	Use category
Insulated render system installed with a 25 mm drained cavity, breather membrane and a specific method for returning any water penetrating the cavity to the external face of the wall. A test has indicated the system is suitable for use in a moderate exposure zone and there is no intention to monitor the installation the system on site.	2	2	10	40	1	Sheltered with increased maintenance and inspection
Insulated render system with the render finish as the sole protection against water ingress. A test has indicated the system is suitable for use in exposed conditions.	4	10	1	40	1	Moderate with increased maintenance and inspection

Insulated render system with the render finish as the sole protection against water ingress. A test has indicated the system is suitable for use in exposed conditions and there is no intention to monitor the installation the system on site.	1	10	10	100	1	Sheltered with increased maintenance and inspection
Insulated render system installed with a 25 mm drained cavity, breather membrane and a specific method for returning any water penetrating the cavity to the external face of the wall. A test has indicated the system is suitable for use in a moderate exposure zone.	4	2	1	4	1	Severe
Insulated render system installed with a 25 mm drained cavity, breather membrane and a specific method for returning any water penetrating the cavity to the external face of the wall. A test has indicated the system is suitable for use in a moderate exposure zone.	4	2	1	4	10	System should be redesigned to incorporate factors that reduce the overall rating and reassessed