

## EUROPEAN ASSESSMENT DOCUMENT

EAD 090019-00-0404

December 2016

# KITS FOR VENTILATED EXTERNAL WALL CLADDINGS OF LIGHTWEIGHT BOARDS ON SUBFRAME WITH RENDERING APPLIED IN SITU WITH OR WITHOUT THERMAL INSULATION

The reference title and language for this EAD is English. The applicable rules of copyright refer to the document elaborated in and published by EOTA.

This European Assessment Document (EAD) has been developed taking into account up-to-date technical and scientific knowledge at the time of issue and is published in accordance with the relevant provisions of Regulation (EU) No 305/2011 as a basis for the preparation and issuing of European Technical Assessments (ETA).

## Contents

<b>1</b>	<b>SCOPE OF THE EAD .....</b>	<b>5</b>
1.1	Description of the construction product .....	5
1.2	Information on the intended use(s) of the construction product .....	7
1.2.1	Intended use(s).....	7
1.2.2	Working life/Durability.....	7
1.3	Specific terms used in this EAD (if necessary in addition to the definitions in CPR, Art 2 .....	7
1.3.1	Kit .....	7
1.3.2	Substrate .....	7
1.3.3	Metal subframe.....	8
1.3.4	Wooden subframe .....	8
1.3.5	Cladding element .....	8
1.3.6	Fixing device of cladding .....	8
1.3.7	Rendering system.....	8
1.3.8	Ventilated air gap.....	9
<b>2</b>	<b>Essential characteristics and relevant assessment methods and criteria.....</b>	<b>10</b>
2.1	Essential characteristics of the product .....	10
2.2	Methods and criteria for assessing the performance of the kit in relation to essential characteristics of the product .....	12
2.2.1	Reaction to fire .....	12
2.2.2	Facade fire performance .....	12
2.2.3	Drainability.....	12
2.2.4	Water absorption .....	12
2.2.5	Content, emission and/or release of dangerous substances .....	13
2.2.6	Wind load resistance of system.....	14
2.2.7	Impact resistance .....	15
2.2.8	Bond strength .....	15
2.2.9	Mechanical resistance of fixing device of cladding element to subframe .....	16
2.2.10	Mechanical resistance of the subframe.....	17
2.2.11	Airborne sound insulation.....	18
2.2.12	Thermal resistance .....	19
2.2.13	Hygrothermal behaviour .....	20
2.2.14	Freeze-thaw behaviour.....	20
2.2.15	Resistance of subframe to corrosion (metallic subframe) and/or deterioration (wooden subframe) .....	21
<b>3</b>	<b>Assessment and verification of constancy of performance .....</b>	<b>23</b>
3.1	System(s) of assessment and verification of constancy of performance to be applied .....	23
3.2	Tasks of the manufacturer .....	23
3.3	Tasks of the notified body .....	27
<b>4</b>	<b>Reference documents .....</b>	<b>28</b>
<b>ANNEX A</b>	<b>Reaction to fire .....</b>	<b>31</b>
<b>ANNEX B</b>	<b>Wind load resistance of the system .....</b>	<b>40</b>
<b>ANNEX C</b>	<b>Impact resistance .....</b>	<b>43</b>
<b>ANNEX D</b>	<b>Hygrothermal behaviour .....</b>	<b>46</b>
<b>ANNEX E</b>	<b>Freeze-thaw behaviour .....</b>	<b>49</b>
<b>ANNEX F</b>	<b>Water absorption – capillarity .....</b>	<b>51</b>

**ANNEX G Mechanical resistance of fixing device of cladding element on subframe ..... 53**

**ANNEX H Pull-through / pull-out resistance test ..... 55**

**ANNEX I Bracket resistance (horizontal and vertical load) ..... 57**

**ANNEX J Assessment methods applied in EU / EFTA member states for assessing the fire performance of facades ..... 63**

## 1 SCOPE OF THE EAD

### 1.1 Description of the construction product

This EAD is applicable to the kits<sup>1</sup> for vertical exterior wall claddings consisting of external cladding elements, which are mechanically fastened by cladding fixing devices to a metallic (galvanized steel, stainless steel or aluminium alloy) or wooden subframe, associated joint materials and subframe fixing devices, rendering system and optionally: thermal insulation and a flexible sheet for waterproofing. The cladding elements are covered subsequently by a rendering system including reinforcement mesh (glass fibre mesh). This kit is fixed to external walls of buildings. Between the cladding element and the thermal insulation or external wall, there is a ventilated air gap, which shall always be drained.

The kit consists of the following components from the rendering system to the substrate:

- Rendering system is composed of base coat (organic and cement based) with reinforcement (glass fibre mesh) and render coating. The render coating is composed of:
  - key coat - organic or organic/ silicate based,
  - finishing coat - organic, organic silicate or cement based,
  - decorative coat - acrylic or acrylic/siloxane based, as option.
- Cladding elements are lightweight boards made of expanded glass granulate and reactive resins with glass-fibre mesh reinforcement on both sides. These cladding elements are characterized by density (480 – 670) kg/m<sup>3</sup>, minimal value of the bending strength 2,6 N/mm<sup>2</sup> and Euroclass of reaction-to-fire A1 or A2.
- Cladding fixing devices (screw, rivet),

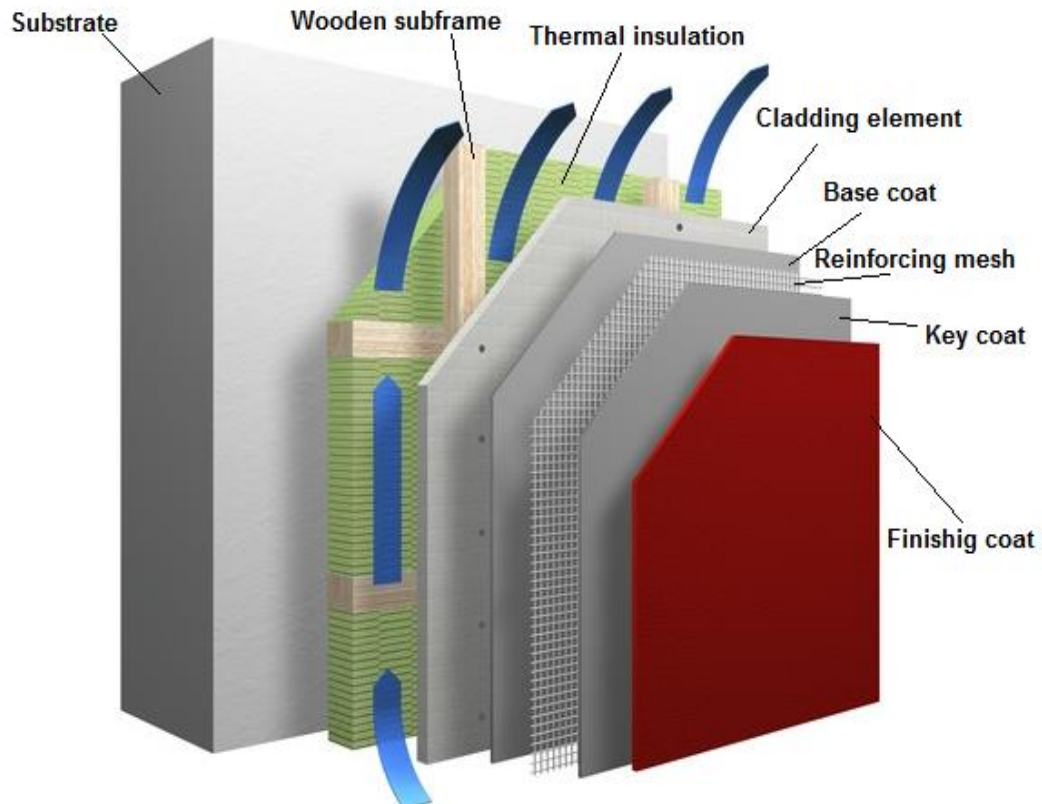

Figure 1 - The fixing method of the cladding elements – wooden subframe

<sup>1</sup> “Kit” means a construction product placed on the market by a single manufacturer as a set of at least two separate components that need to be put together to be incorporated in the construction works (Art. 2 n° 2 CPR)

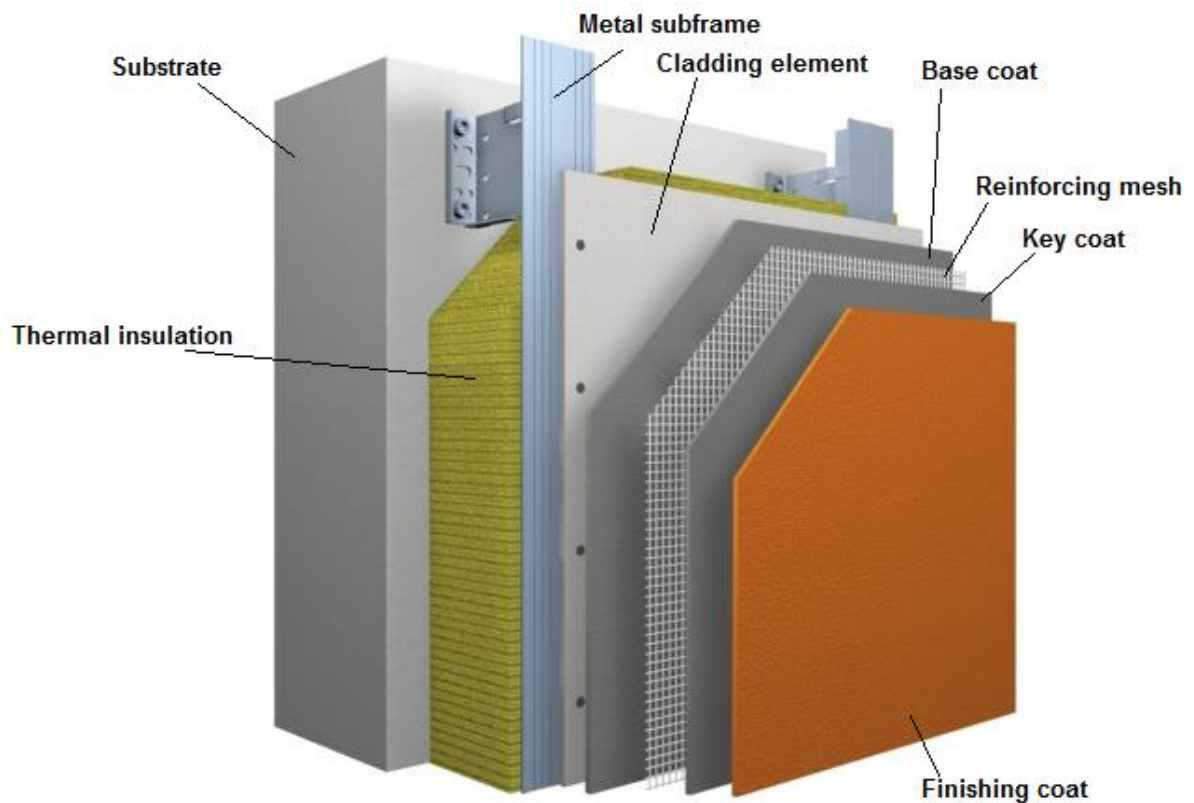

Figure 2 - The fixing method of the cladding elements – metal subframe

- Metal subframe components (vertical profiles, brackets and subframe fixing devices between profiles, between profiles and brackets and between brackets and substrate),
- Wooden subframe components (vertical and horizontal studs as defined in EN 14081-1, subframe fixing devices between vertical and horizontal studs and between studs and substrate),
- Thermal insulation as defined in EN 13162 (mineral wool /MW/ products), of class of reaction to fire A1 or A2,
- Flexible sheet for waterproofing as defined in EN 13956, placed on the outer face of the thermal insulation.

Thermal insulation and flexible sheet for waterproofing are optional parts of product.

The manufacturer can provide:

- A complete kit (rendering system, cladding element, cladding fixing devices, flexible sheet for waterproofing, thermal insulation, and subframe components)
- A minimum kit (rendering system, cladding element, cladding fixing devices and subframe components)

The kits are a non-load-bearing construction element. They do not contribute directly to the stability of the wall on which they are installed but can contribute to durability by providing enhanced protection from the effects of weathering. The kits can improve thermal resistance of walls by applying thermal insulation directly on the wall substrate.

The product is not fully covered by ETAG 034 (June 2012). ETAG 034 does not cover external wall cladding kits where the cladding element is made of panel covered by rendering system applied in situ.

Concerning product packaging, transport, storage, maintenance, replacement and repair it is the responsibility of the manufacturer to undertake the appropriate measures and to advise his clients on the transport, storage, maintenance, replacement and repair of the product as he considers necessary.

It is assumed that the product will be installed according to the manufacturer's instructions or (in absence of such instructions) according to the usual practice of the building professionals.

Relevant manufacturer's stipulations having influence on the performance of the product covered by this European Assessment Document shall be considered for the determination of the performance and detailed in the ETA.

## **1.2 Information on the intended use(s) of the construction product**

### **1.2.1 Intended use(s)**

This EAD covers the intended use of external wall claddings in ventilated façade (rainscreens) to be fixed to external vertical walls. They can also be used on inclined surfaces where are not exposed to precipitation. The substrate walls are made of masonry (clay, concrete or stone), concrete (cast on site or as prefabricated panels), timber or metal frame in new or existing buildings (retrofit).

The fixing devices (between subframe and substrate and between thermal insulation and substrate) whether they form part of the kit or not are not covered by this EAD. The fixing devices shall be defined according to relevant specifications (hEN, EAD or national approval).

### **1.2.2 Working life/Durability**

The assessment methods included or referred to in this EAD have been written based on the manufacturer's request to take into account a working life of the kits for the intended use of at least 25 years when installed in the works (provided that the kits is subject to appropriate installation (see 1.1)). These provisions are based upon the current state of the art and the available knowledge and experience.

When assessing the product, the intended use as foreseen by the manufacturer shall be taken into account. The real working life may be, in normal use conditions, considerably longer without major degradation affecting the basic requirements for works<sup>2</sup>.

The indications given as to the working life of the construction product cannot be interpreted as a guarantee neither given by the product manufacturer or his representative nor by EOTA when drafting this EAD nor by the Technical Assessment Body issuing an ETA based on this EAD, but are regarded only as a means for expressing the expected economically reasonable working life of the product.

## **1.3 Specific terms used in this EAD (if necessary in addition to the definitions in CPR, Art 2**

### **1.3.1 Kit**

A kit is a specific kit composed by a lightweight cladding element, its cladding fixing devices, rendering system, subframe and optionally a thermal insulation and a flexible sheet for waterproofing, which is used as rainscreen of external walls.

### **1.3.2 Substrate**

The term "substrate" refers to a wall, which in itself already meets the necessary airtightness and mechanical strength requirements (resistance to static and dynamic loads), as well as a relevant watertightness and water vapour resistance. The substrate walls can be made of masonry (clay, any kind of concrete or stone), concrete (cast on site or as prefabricated panels), timber or metal frame.

---

<sup>2</sup> The real working life of a product incorporated in a specific works depends on the environmental conditions to which that works is subject, as well as on the particular conditions of the design, execution, use and maintenance of that works. Therefore, it cannot be excluded that in certain cases the real working life of the product may also be shorter than referred to above.

### 1.3.3 Metal subframe

An intermediate assembly of vertical and/or horizontal metal profiles and brackets (including the substrate fixing devices between the brackets and the profiles) located between the cladding element and the substrate.

### 1.3.4 Wooden subframe

An intermediate assembly of vertical and/or horizontal wooden studs (including the subframe fixing devices between the horizontal and vertical studs) located between the cladding element and the substrate

The wooden subframe is considered to satisfy the requirements for performance class D-s2, d0 of the characteristic reaction to fire, in accordance with the provisions of EC decision 2000/147/EC, Table 1 (as amended) without the need for testing on the basis of its listing in that decision.

### 1.3.5 Cladding element

Cladding elements are lightweight boards made of expanded glass granulate and reactive resins with glass-fibre mesh reinforcement on both sides. These cladding elements are characterized by density (480 – 670) kg/m<sup>3</sup> and minimal value of the bending strength 2,6 N/mm<sup>2</sup> and they are applied at the external face of an external wall.

### 1.3.6 Fixing device of cladding

Screws/anchors, nails, rivets or any special fixing devices used to secure the cladding element to the subframe.

### 1.3.7 Rendering system

Rendering system is composed of render coating (base coat, key coat, finishing coat and decorative coat and reinforcement mesh.

- Reinforcement mesh  
Glass fibre mesh in base coat improving its mechanical characteristics.
- Render coating  
The rendering is applied to the cladding element in one or several coats (application of a new coat on top of an existing dry coat). Installation can also be done in several layers (putting one layer on top of a fresh layer). Generally, multi-coat renders include the following:
  - Base coat: Coat applied directly onto the cladding element; the reinforcement is embedded into it and provides most of the mechanical properties of the rendering,
  - Key coat: Very thin coat which may be applied to the base coat and is intended to act as a preparation for the application of the finishing coat. It can also be possibly used for aesthetic reasons,
  - Finishing coat: Coat which contributes to the protection against weathering and can provide a decorative finish; it is applied onto the base coat with or without a key coat,  
Type of finishing coat: Where the only difference between two finishing coats is due to the size of the aggregates, they are designed as one type.
  - Decorative coat: Coat which generally contributes to the aesthetic finishing (to cover efflorescence...) of the finishing coat and can also provide supplementary protection against weathering.

*Note:* In case where no more layers are applied on a base coat (the base coat functions as a finishing coat as well), the application of a finishing coat prescribed in test procedures shall be omitted.



### 1.3.8 Ventilated air gap

A layer of air between the substrate or insulation layer and cladding elements connected to the external environment permitting the dry-out of the water that may be found in this space due to condensations or rain penetration and the water vapour diffusion from the internal side of the wall.

External wall claddings are considered as ventilated when the following criteria are fulfilled:

- The distance between the cladding elements and the insulation layer or the substrate accordingly (ventilation air gap) amounts to at least 20 mm. This air gap may be reduced locally to 5 up to 10 mm depending on the cladding and the subframe, provided that it is verified that it does not affect the draining and/or ventilation function,
- Ventilation openings are envisaged, as a minimum, at the building base point and at the roof edge with cross-sections of at least 50 cm<sup>2</sup> per linear metre.

## 2 ESSENTIAL CHARACTERISTICS AND RELEVANT ASSESSMENT METHODS AND CRITERIA

### 2.1 Essential characteristics of the product

Table 1 show how the performance of the kit is assessed in relation to the essential characteristics.

The characteristic airborne sound insulation and thermal resistance are relevant only if the thermal insulation is included in the kit.

**Table 1 Essential characteristics of the kit and methods assessment methods and criteria for the performance of the product in relation to those essential characteristics**

No	Essential characteristic	Assessment method	Type of expression of product performance
<b>Basic Works Requirement 2: Safety in case of fire</b>			
1	Reaction to fire <ul style="list-style-type: none"> <li>• Reaction to fire</li> <li>• Reaction to fire on rear side</li> </ul>	Clause 2.2.1	Class Class
2	Facade fire performance	Clause 2.2.2	Level, Description
<b>Basic Works Requirement 3: Hygiene, health and the environment</b>			
3	Drainability	Clause 2.2.3	Description
4	Water absorption of rendering system on cladding element <ul style="list-style-type: none"> <li>• After 1 hour</li> <li>• After 24 hour</li> </ul>	Clause 2.2.4	Level Level
5	Content, emission and/or release of dangerous substances <ul style="list-style-type: none"> <li>• SVOC and VOC</li> <li>• Leachable substances</li> <li>• Biocides for wood preservatives</li> </ul>	Clause 2.2.5 Clause 2.2.5.1 Clause 2.2.5.2 Clause 2.2.5.3	Description Description Description
<b>Basic Works Requirement 4: Safety and accessibility in use</b>			
6	Wind load resistance of the system <ul style="list-style-type: none"> <li>• Wind load resistance of system in after-installation stage</li> <li>• Mechanical resistance of the fixing device for connection of subframe bracket to substrate <ul style="list-style-type: none"> <li>• Pull-out/pull-through resistance of fixing device under tensile load from subframe bracket in after-installation stage</li> <li>• Shear resistance of fixing device in subframe bracket in after-installation stage</li> </ul> </li> <li>• Bending strength and modulus of elasticity of the cladding element <ul style="list-style-type: none"> <li>• In after-installation stage</li> <li>• After hygrothermal cycles</li> <li>• After freeze/thaw cycles</li> <li>• After immersion in water</li> </ul> </li> </ul>	Clause 2.2.6	Level  Level, Description  Level, Description  Level Level Level Level
7	Impact resistance <ul style="list-style-type: none"> <li>• In after-installation stage</li> <li>• After hygrothermal cycles</li> </ul>	Clause 2.2.7	Class Class and description
8	Bond strength of rendering system on cladding element <ul style="list-style-type: none"> <li>• In after-installation stage</li> <li>• After hygrothermal cycles</li> <li>• After freeze/thaw cycles</li> </ul>	Clause 2.2.8	Level Level and description Level and description

No	Essential characteristic	Assessment method	Type of expression of product performance
9	<p>Mechanical resistance of fixing device of cladding element to subframe</p> <ul style="list-style-type: none"> <li>• Pull-out/pull-through resistance of fixing device from cladding element under tensile load <ul style="list-style-type: none"> <li>• in after-installation stage</li> <li>• after hygrothermal cycles</li> <li>• after freeze/thaw cycles</li> </ul> </li> <li>• Shear resistance of fixing device in cladding element <ul style="list-style-type: none"> <li>• in after-installation stage</li> <li>• after hygrothermal cycles</li> <li>• after freeze/thaw cycles</li> </ul> </li> <li>• Pull-out/pull-through resistance of fixing device from subframe under tensile load <ul style="list-style-type: none"> <li>• in after-installation stage</li> </ul> </li> <li>• Shear resistance of fixing device in subframe <ul style="list-style-type: none"> <li>• in after-installation stage</li> </ul> </li> </ul>	Clause 2.2.9	<p>Level</p> <p>Level and description</p> <p>Level and description</p> <p>Level</p> <p>Level and description</p> <p>Level and description</p> <p>Level</p> <p>Level</p>
10	<p>Mechanical resistance of subframe</p> <ul style="list-style-type: none"> <li>• Resistance of subframe bracket to horizontal load <ul style="list-style-type: none"> <li>• at 1 mm residual distortion</li> <li>• at failure mode</li> </ul> </li> <li>• Resistance of subframe bracket to vertical load <ul style="list-style-type: none"> <li>• at <math>\Delta L</math> mm residual distortion</li> <li>• at 1 mm displacement</li> <li>• at 3 mm displacement</li> <li>• at failure mode</li> </ul> </li> <li>• Inertia moment of the cross-cut section of metallic profile for subframe (only if metallic subframe is used)</li> <li>• Resistance to combined vertical and horizontal load of connection between subframe profile and bracket</li> </ul>	Clause 2.2.10	<p>Level</p> <p>Level</p> <p>Level</p> <p>Level</p> <p>Level</p> <p>Level</p> <p>Level</p>
<b>Basic Works Requirement 5: Protection against noise</b>			
11	Airborne sound insulation	Clause 2.2.11	Level
<b>Basic Works Requirement 6: Energy economy and heat retention</b>			
12	Thermal resistance	Clause 2.2.12	Level
<b>Basic Works Requirement 7: Sustainable use of natural resources</b>			
13	Hygrothermal behaviour	Clause 2.2.13	Description
14	Freeze/thaw behaviour	Clause 2.2.14	Description
15	<p>Resistance of subframe to corrosion (metallic subframe) and/or deterioration (wooden subframe)</p> <ul style="list-style-type: none"> <li>• Resistance of metallic subframe and/or metallic parts of subframe to corrosion</li> <li>• Resistance of wooden parts of subframe to deterioration</li> </ul>	Clause 2.2.15	<p>Level / Description</p> <p>Level / Description</p>

## 2.2 Methods and criteria for assessing the performance of the kit in relation to essential characteristics of the product

### 2.2.1 Reaction to fire

#### 2.2.1.1 Reaction to fire

The reaction to fire of the kit is to be classified according to Commission Delegated Regulation (EU) No. 2016/364 and EN 13501-1.

The kit is to be classified either by considering the reaction to fire of the all substantial kit components (rendering system, cladding element, subframe, thermal insulation and waterproofing layer), or, when relevant, by using the test method(s) relevant for the corresponding class of reaction to fire on front side of the kit according to EN 13501-1. Associated mounting and fixing rules for the SBI test are given in Annex A, Cl. A.2.1.1.

The worst class of any substantial component obtained according to a CWFT Decisions and criteria indicated in Annex A are to be taken into account.

The class of reaction to fire of the kit is given in the ETA.

#### 2.2.1.2 Reaction to fire on rear side

When relevant due to asymmetrically composed cladding elements or relevant surfaces of the kit components in ventilated air gap, reaction to fire on rear side is to be classified according to Commission Delegated Regulation (EU) 2016/364 and EN 13501-1

The kit on rear side is to be classified in this case either by considering the reaction to fire of the all substantial kit components (rendering system, cladding element, subframe, thermal insulation and waterproofing layer), or by using the test method(s) relevant for the corresponding class of reaction to fire on rear side of the kit according to EN 13501-1. Associated mounting and fixing rules for the SBI test are given in Annex A, Cl. A.2.1.2.

The class of reaction to fire on rear side is given in the ETA.

### 2.2.2 Facade fire performance

If the manufacturer intends to declare the façade fire performance of the product, in absence of a European assessment approach, the ETA shall be issued taking into account the situation in Member States where the manufacturer intends his product to be made available on the market.

Information about such situation is included in Annex J.

### 2.2.3 Drainability

Verification of the drainability of the kit is to be performed by calculation of interstitial condensation according to ISO 13788. Cl. 5, at least for the critical case (kit with the minimal air space between cladding element and thermal insulation (and/or substrate), specified by manufacturer).

The information, that the kit is designed so that  $f_{Rsi,max}$  for the critical month (month with the highest required value of  $f_{Rsi,min}$ ) according to ISO 13788, Cl. 5.3, is always exceeded (i.e.  $f_{Rsi} > f_{Rsi,max}$ ), is given in the ETA.

### 2.2.4 Water absorption

The water absorption of the rendering system shall be determined by test according to the method indicated in Annex F.

These tests have 3 purposes, to determine:

- The water absorption, in order to assess, in Annex F, whether it is acceptable,

- Which finishing coats should be applied on the rig to be subjected to hygrothermal testing (see Cl. 2.2.13),
- Whether the freeze-thaw testing described in Cl. 2.2.14 is necessary.

The water absorption after 1 hour  $A_{w,1}$  [ $\text{kg}/\text{m}^2$ ] and 24 hours  $A_{w,24}$  [ $\text{kg}/\text{m}^2$ ] is given in the ETA.

### 2.2.5 Content, emission and/or release of dangerous substances

The performance of the hardened bonding material related to the emissions and/or release and, where appropriate, the content of dangerous substances will be assessed on the basis of the information provided by the manufacturer<sup>3</sup> after identifying the release scenarios (in accordance with EOTA TR 034) taking into account the intended use of the product and the Member States where the manufacturer intends his product to be made available on the market. Purely inorganic materials (e.g. boards, adhesives) and uncoated steel or aluminium profiles do not have to be tested.

The identified intended release scenarios for this product and intended use with respect to dangerous substances are:

- IA2: Product with indirect contact to indoor air (e.g. covered products) but possible impact on indoor air
- S/W1: Product with direct contact to soil, ground- and surface water
- S/W2: Product with indirect contact to soil, ground- and surface water.

#### 2.2.5.1 SVOC and VOC

For the intended uses covered by the release scenarios IA2, semi-volatile organic compounds (SVOC) and volatile organic compounds (VOC) shall be determined in accordance with EN 16516. The loading factor to be used for emission testing is  $0,007 \text{ m}^2/\text{m}^3$ .

The preparation of the test specimen is to be performed as follows: The inert substrate (glass or stainless steel) shall be coated by tested material as described in the manufacturer's instructions. Testing is performed using  $\frac{3}{4}$  of the maximum wet film thickness according to the manufacturer's instructions. For each layer the quantity applied is verified in terms of wet weight [ $\text{g}/\text{m}^2$ ] by taking weight differences.

The coating shall be carried out exactly in accordance with the manufacturer's specifications. Environmental conditions and drying time have to be reported. Cross contaminations shall be avoided.

Once the test specimen has been completely coated, it is preconditioned for 3 or 28 days. The preconditioning process takes place in a test chamber under the test chamber conditions or in a storage facility where the relevant test chamber conditions can be created.

Once the preconditioning time has been observed, the test specimen is transferred to the emission test chamber. This point in time is considered to be the starting time of the emission test. A 28-day test period using the area-specific air flow rate  $q = 1,5 \text{ m}/\text{h}$  takes place.

The test results have to be reported for the relevant parameters (e.g. chamber size, temperature and relative humidity, air exchange rate, loading factor, size of test specimen, preconditioning, production date, arrival date, test period, test result).

The relevant test results after 28 days shall be expressed in [ $\text{mg}/\text{m}^3$ ] and given in the ETA.

---

<sup>3</sup> The manufacturer may be asked to provide to the TAB the REACH related information which he must accompany the DoP with (cf. Article 6(5) of Regulation (EU) No 305/2011). The manufacturer is **not** obliged:

- to provide the chemical constitution and composition of the product (or of constituents of the product) to the TAB, or
- to provide a written declaration to the TAB stating whether the product (or constituents of the product) contain(s) substances which are classified as dangerous according to Directive 67/548/EEC and Regulation (EC) No 1272/2008 and listed in the "Indicative list on dangerous substances" of the SGDS.

Any information provided by the manufacturer regarding the chemical composition of the products may not be distributed to EOTA or to TABs.

### 2.2.5.2 Leachable substances

For the intended use covered by the release scenario S/W1 or S/W2 the performance of the rendering system applied on cladding element (sub-kit) concerning leachable substances is to be assessed. A leaching test with subsequent eluate analysis must take place, each in duplicate. Leaching tests of the test specimens are conducted according to CEN/TS 16637-2:2014. The leachant shall be pH-neutral demineralised water and the ratio of liquid volume to surface area shall be  $(80 \pm 10) \text{ l/m}^2$ .

The sub-kit to be tested shall be assembled according to manufacturers instructions. Preparation is performed using  $\frac{3}{4}$  of the maximum wet film thickness for each layer. The quantity applied in each layer is verified in terms of wet weight  $[\text{g/m}^2]$  by taking weight differences.

Before testing, the prepared samples are stored for at least 28 days at  $(23 \pm 2) \text{ }^\circ\text{C}$  and  $(50 \pm 5) \text{ \% RH}$ .

In eluates of "6 hours" and "64 days", the following biological tests shall be conducted:

- Acute toxicity test with *Daphnia magna* Straus according to EN ISO 6341
- Toxicity test with algae according to ISO 15799
- Luminescent bacteria test according to EN ISO 11348-1, EN ISO 11348-2 or EN ISO 11348-3

For each biological test, EC20-values shall be determined for dilution ratios 1:2, 1:4, 1:6, 1:8 and 1:16.

If the parameter TOC is higher than 10 mg/l, the following biological tests shall be conducted with the eluates of "6 hours" and "64 days":

- Biological degradation according to OECD Test Guideline 301 part A, B or E.

Determined toxicity in biological tests shall be expressed as EC20-values for each dilution ratio and given in the ETA. Maximum determined biological degradability shall be expressed as "... % within ... hours/days". The respective test methods for analysis shall be specified.

### 2.2.5.3 Biocidity of wood preservatives

Only biocides for wood preservatives approved by Regulation (EU) No. 528/2012 may be applied. The use of biocide(s) shall be indicated by the manufacturer following the criteria set out in EN 15228. Used biocides, specified by manufacturer, are given in the ETA.

## 2.2.6 Wind load resistance of system

### 2.2.6.1 Wind load resistance of system in after-installation stage

The wind load resistance (suction and/or pressure) of the kit is to be verified by calculation according to EN 1999-1-1 for aluminium subframe or EN 1995-1-1 for wooden subframe.

The mechanical resistance of the kit components (cladding element, fixing devices and subframe components) obtained from Cl. 2.2.9 to 2.2.10 are to be considered in elasticity and resistance equations for the calculation of ultimate and serviceability limit states.

At least for the critical case of the kit (the mechanically weakest case) the calculated result is to be verified by test of one test specimen according to the method indicated in Annex B.

If the test result obtained doesn't confirm the results obtained by calculation based on mechanical tests of the kit components, either at least two other test specimens have to be tested or the mechanical resistance of the kit is to be corrected accordingly.

The wind load resistance of the kit appointed as the weakest level of failure of any kit component or the kit itself by calculation and by test is given the ETA.

### 2.2.6.2 Mechanical resistance of the fixing device for connection of subframe bracket to substrate

#### 2.2.6.2.1 Pull-out/pull-through resistance of fixing device under tensile load from subframe bracket in after-installation stage

This characteristic is to be assessed by calculation according to EN 1993-1-1 or EN 1999-1-1 and/or by test of wind load resistance of system according to Cl. 2.2.6.1.

The value acquired by calculation and/or by test is given in the ETA.

#### **2.2.6.2.2 Shear resistance of fixing device in subframe bracket in after-installation stage**

This characteristic is to be assessed by calculation according to EN 1993-1-1 or EN 1999-1-1 and/or by test of wind load resistance of system according to Cl. 2.2.6.1.

The value acquired by calculation and/or by test is given in the ETA.

#### **2.2.6.3 Bending strength and modulus of the elasticity of the cladding element**

The bending strength and modulus of the elasticity of the cladding element is to be determined on test specimens by testing in accordance to the method given in EN 12467, Cl. 7.3.2.

The bending strength and modulus of the elasticity of the cladding element are to be tested in ambient conditions (in after-installation stage) and also with consideration of aspects of durability (test after hygrothermal cycles, test after freeze-thaw cycles and test after immersion in water).

Immersion in water is carried out according to EN 12467, Tab. 10, row "Acceptance test (wet), Categories A and B".

These values of the bending strength and modulus of the elasticity are given in the ETA:

- Bending strength in after-installation stage  $MOR_r$  [MPa]
- Bending strength after hygrothermal cycles  $MOR_h$  [MPa] (see Cl. 2.2.13)
- Bending strength after freeze-thaw cycles  $MOR_{ft}$  [MPa] (see Cl. 2.2.14)
- Bending strength after immersion in water  $MOR_i$  [MPa]
- Modulus of the elasticity in after-installation stage  $MOE_r$  [GPa]

#### **2.2.7 Impact resistance**

The test of the impact resistance is to be performed as described in Annex C. The hygrothermal cycles are performed as described in Cl. 2.2.13.

The impact resistance category and its description, as defined in Annex C (on the test specimens in after-installation stage and/or on the test specimens after hygrothermal cycles) are given in the ETA.

#### **2.2.8 Bond strength**

The bond strength of the rendering system is to be tested according to EN 1015-12.

The test is to be carried out for each combination of base coat (with the reinforcement mesh) and the respective finishing coat to be specified by manufacturer.

The test specimens are to be prepared with the cladding element type (lightweight board) as the substrate.

The test specimens are to be prepared at the same time that:

- The rig for the hygrothermal behaviour test (see Cl. 2.2.13), and
- The sample for freeze-thaw test (see Cl. 2.2.14).

Additionally, the bond strength is to be tested:

- On sample taken from the rig after hygrothermal cycles (see Cl. 2.2.13)
- On sample after simulated freeze-thaw test (see Cl. 2.2.14)

All the mean values of the bond strength between rendering system and cladding element after each conditioning have to fulfil following:

- to be at least equal to 80 kPa with cohesive or adhesive rupture. One single value lower than 80 kPa but higher than 60 kPa is admissible,

or

- the rupture occurs in the cladding element (cohesive rupture) if the failure resistance is lower than 80 kPa.

Characteristic value of bond strength after each type of conditioning [kPa] as 95 % quartile on confidence level 75 % for  $V_x$  as unknown according to EN 1990, Annex D, Cl. 7.2 shall be calculated for each conditions separately.

These types of bond strength values are given in the ETA:

- Bond strength in after-installation stage  $f_{u(r)}$  [N/mm<sup>2</sup>]
- Bond strength after hygrothermal cycles  $f_{u(h)}$  [N/mm<sup>2</sup>] (see Cl. 2.2.13)
- Bond strength after freeze-thaw cycles  $f_{u(t/h)}$  [N/mm<sup>2</sup>] (see Cl. 2.2.14)

## 2.2.9 Mechanical resistance of fixing device of cladding element to subframe

### 2.2.9.1 Pull-out/ pull-through resistance of fixing device from cladding element under tensile load

The pull-out/pull-through resistance of fixing device from cladding element under tensile load is to be determined by testing of test specimens in accordance with the test method given in Annex G.

The most critical case of the kit is given in the ETA.

The test is to be performed in ambient conditions (test on reference specimen) and with consideration of aspects of durability (test after hygrothermal cycles and test after freeze-thaw cycles).

Characteristic value of pull-out/ pull-through resistance of fixing device from cladding element under tensile load [kN] as 95 % quartile on confidence level 75 % for  $V_x$  as unknown according to EN 1990, Annex D, Cl. 7.2 shall be calculated for each conditions separately.

These characteristic values of the pull-out/ pull-through resistance of fixing device from cladding element under tensile load for each implantation and each ring are given in the ETA.

- Pull-out/ pull-through resistance in after-installation stage  $R_{t(r)}$  [N]
- Pull-out/ pull-through resistance after hygrothermal cycles  $R_{t(h)}$  [N] (see Cl. 2.2.13)
- Pull-out/ pull-through resistance after freeze-thaw cycles  $R_{t(t/h)}$  [N] (see Cl. 2.2.14)

### 2.2.9.2 Shear resistance of fixing device in cladding element

The shear resistance of fixing device in cladding element is to be determined by testing of test specimens in accordance with the test method given in Annex G.

The most critical case of the kit is given in the ETA.

The shear resistance of fixing device is to be tested in ambient conditions (test on reference specimen) and with consideration of aspects of durability (test after hygrothermal cycles and test after freeze-thaw cycles).

Characteristic value of shear resistance of fixing device in cladding element [kN] as 95 % quartile on confidence level 75 % for  $V_x$  as unknown according to EN 1990, Annex D, Cl. 7.2 shall be calculated for each conditions separately.

These characteristic values of the shear resistance are given in the ETA:



- Shear resistance in after-installation stage  $R_{sl(r)}$  [N]
- Shear resistance after hygrothermal cycles  $R_{sl(h)}$  [N] (see Cl. 2.2.13)
- Shear resistance after freeze-thaw cycles  $R_{sl(th)}$  [N] (see Cl. 2.2.14)

### 2.2.9.3 Pull-out/pull-through resistance of fixing device from subframe under tensile load

The pull-through / pull-out resistance of fixing device from subframe under tensile load on relevant profiles (e.g. vertical profiles, horizontal profiles, etc.) is to be determined by testing according to the method indicated in the Annex H.

Characteristic value of pull-out/pull-through resistance of fixing device from subframe under tensile load [kN] as 95 % quartile on confidence level 75 % for  $V_x$  as unknown according to EN 1990, Annex D, Cl. 7.2 shall be calculated for each conditions separately.

These characteristic values are given in the ETA:

- Resistance to pull-through  $R_{SC(p-t)}$  [N] and/or
- Resistance to pull-out  $R_{SC(p-o)}$  [N] and/or

### 2.2.9.4 Shear resistance of fixing device in subframe

This characteristic is to be assessed by calculation according to EN 1993-1-1 or EN 1999-1-1 or EN 1995-1-1 and/or by test of wind load resistance of system according to Cl. 2.2.6.1.

The value acquired by calculation and/or test is given in the ETA.

### 2.2.9.5 Mechanical resistance of fixing device of cladding element to subframe under combination of tensile and shear loads

This characteristic is to be assessed by calculation according to EN 1993-1-1 or EN 1999-1-1 or EN 1995-1-1 and/or by test of wind load resistance of system according to Cl. 2.2.6.1.

The value acquired by calculation and/or by test is given in the ETA.

## 2.2.10 Mechanical resistance of the subframe

### 2.2.10.1 Resistance of subframe bracket to horizontal load

The resistance to horizontal loads is to be tested according to the method indicated in Annex I.

When it is possible, calculation according to relevant standards can be carried out provided that this calculation is contrasted by testing according to the method indicated in Annex I.

Characteristic value of resistance of subframe bracket to horizontal load [kN] as 95 % quartile on confidence level 75 % for  $V_x$  as unknown according to EN 1990, Annex D, Cl. 7.2 shall be calculated for each conditions separately.

These characteristic values are given in the ETA:

- Resistance to horizontal load
  - Characteristic resistance at 1 mm residual distortion  $R_{cr}$  [N]
  - Characteristic resistance at failure  $R_t$  [N]

### 2.2.10.2 Resistance of subframe bracket to vertical load

The resistance to vertical loads is to be tested according to the method indicated in Annex I.

When it is possible, calculation according to relevant standards can be carried out provided that this calculation is contrasted by testing according to the method indicated in Annex I.

Characteristic value of resistance of subframe bracket to vertical load [kN] as 95 % quartile on confidence level 75 % for  $V_x$  as unknown according to EN 1990, Annex D, Cl. 7.2 shall be calculated for each conditions separately.

These characteristic values are given in the ETA:

- Resistance to vertical load
  - Characteristic resistance at  $\Delta L = \frac{0,2 \cdot L_x}{100}$  mm displacement  $R_{cr}$  [N]
  - Characteristic resistance at 1 mm displacement  $R_{cd1}$  [N]
  - Characteristic resistance at 3 mm displacement  $R_{cd3}$  [N]
  - Characteristic resistance at failure  $R_s$  [N]

### 2.2.10.3 Inertia moment of the cross-cut section of metallic profile for subframe

Dimensions of the cross-cut section of profile are to be measured according to EN 14195, Cl. 4.

The inertia moment of the cross-cut section of metallic profiles for subframe is to be calculated (e.g. according to EN 14195, Annex B) from nominal values of dimensions for relevant profiles (e.g. vertical and horizontal profiles).

The calculated values of the inertia moment of the profile section  $I [mm^4]$  are given in the ETA.

### 2.2.10.4 Resistance to combined vertical and horizontal load of connection between subframe profile and bracket

This characteristic is to be assessed by calculation according to EN 1993-1-1 or EN 1999-1-1 or EN 1995-1-1 and/or by test of wind load resistance of system according to Cl. 2.2.5.1.

The value acquired by calculation and/or by test is given in the ETA.

### 2.2.11 Airborne sound insulation

The acoustic performance of a kit is to be determined on the basis of laboratory tests carried out in accordance with the standards EN ISO 10140-1, EN ISO 10140-2, EN ISO 10140-4 and EN ISO 10140-5.

The kit shall be tested on the relevant type of wall according to EN ISO 10140-1, Annex G.2, c).

The direct difference of the weighted sound reduction indices of the wall with and without the kit,  $\Delta R_{W,direct}$ ,  $\Delta(R_W + C)_{direct}$  and  $\Delta(R_W + C_{tr})_{direct}$ , shall be reported as evaluated according to EN ISO 10140-1 Annex G together with the description of the wall used for testing.

For the configuration of the kit to be tested, the following rules shall be taken into account:

- Insulation products with higher dynamic stiffness provide worse performance,
- Insulation products with lower air flow resistance provide worse performance,
- A higher number of fixing devices provides worse performance,
- A higher mass of a rendering system provides better performance,
- A greater thickness of the insulation product provides better performance,
- The performance for an insulation product thickness between two tested ones can be linearly interpolated,
- Anchors with plastic screws/nails provide better performance than with metal screws/nails.

If tests have been performed, single number improvement values  $\Delta R_{W,direct} [dB]$ ,  $\Delta(R_W + C)_{direct} [dB]$  and  $\Delta(R_W + C_{tr})_{direct} [dB]$  are given in the ETA together with a detailed description of the tested configuration of the kit, including at least:

- Type, thickness, air flow resistance (for porous insulation products) and dynamic stiffness of the insulation product,
- Description and mass ( $kg/m^2$ ) of the rendering system,
- Types, number and application method of kit fixing device,
- Type and characteristics (dimensions, mass ( $kg/m^2$ ), nature, design (drawing)) of substrates (walls).

The following extension rules apply:

- The performance measured may also be used for heavier rendering systems than that measured (all other parameters identical),
- The performance measured may also be used for the same type of insulation product with lower dynamic stiffness than that measured (all other parameters identical),
- If the performance has been measured with different thicknesses of insulation product (all other parameters identical) the values at an intermediate thickness can be obtained by linear interpolation,
- The performance measured may also be used for the same type of insulation product with greater thickness than that measured (all other parameters identical),
- The performance measured may also be used for a kit fixed with fewer fixings than that measured (all other parameters identical),
- The performance measured on the heavy wall (according to the definition in EN ISO 10140-5 Annex B) may be used for all other heavy walls (of mass per square meter between  $150 kg/m^2$  and  $400 kg/m^2$ ).

### 2.2.12 Thermal resistance

This characteristic is relevant only if the thermal insulation is included in the kit. At least the critical kit with the minimal thickness of thermal insulation shall be calculated or tested.

The thermal resistance of the kit is given as the middle value for the portion of main kit parts (subframe profiles, brackets, cladding elements, etc.) in relation to  $1 m^2$  of the kit.

The thermal resistance of the kit without effect of thermal bridges is to be calculated according to EN ISO 6946, using the design thermal conductivity values for materials according to EN ISO 10456, or thermal conductivity determined according to EN ISO 10456 if relevant (the thermal insulation is used).

Verification of the effect of thermal bridges caused by subframe, mechanical fixing devices and air gaps can be performed by calculations according to EN ISO 10211. The thermal resistance of the kit can be verified alternatively by testing according to EN ISO 8990.

The thermal resistance values for the kit are to be set as the total thermal resistance  $R_{D(k)} [m^2.K/W]$  including the surface resistances.

The value of the thermal resistance of the kit  $R_{D(k)} [m^2.K/W]$  with built-in thermal insulation will exceed  $0,5 m^2.K/W$ .

Following values of the thermal resistance of the kit  $R_{D(k)} [m^2.K/W]$  are given in the ETA:

- the thermal resistance of the kit  $R_{D(k)}$  without effect of thermal bridges
- the thermal resistance of the kit  $R_{D(k)}$  with effect of thermal bridges.

### 2.2.13 Hygrothermal behaviour

The test of hygrothermal behaviour of the kit is to be performed on test specimens in accordance with the test method given in Annex D.

After the hygrothermal behaviour test, the following additional tests are to be carried out on the test specimens taken of the rig or kit components:

- Impact resistance (see Cl. 2.2.7),
- Bond strength test (see Cl. 2.2.8),
- Mechanical resistance of fixing device of cladding element on subframe (see Cl. 2.2.9.1 and 2.2.9.2).

The test of hygrothermal behaviour is evaluated to be satisfactory, if the following defects shall occur neither during nor after the test:

- Deterioration such as cracking or delamination of the rendering system that allows water penetration to the cladding element,
- Deterioration or cracking associated with joints between the cladding element,
- Detachment of the rendering system,
- Irreversible deformation,
- The particular value of bond strength after test of hygrothermal behaviour is evaluated as to be satisfactory if:
  - The minimum failure bond strength value has to be at least 80 kPa with cohesive or adhesive rupture,
  - or
  - The rupture occurs in the cladding element (cohesive rupture) if failure resistance is less than 80 kPa.

Characteristic values of bond strength [kPa] and of mechanical resistance of fixing device of cladding element to subframe [kN], all after test of hygrothermal behaviour, as 95 % quartile on confidence level 75 % for  $V_{\alpha}$  as unknown according to EN 1990, Annex D, Cl. 7.2 shall be calculated.

The following characteristics related to hygrothermal behaviour of the kit are given in the ETA:

- Impact resistance after test of hygrothermal behaviour,
- Characteristic value(s) of bond strength after test of hygrothermal behaviour,
- Characteristic value(s) of mechanical resistance of fixing device of cladding element to subframe [kN] after test of hygrothermal behaviour,
- Description of the test specimen (its defects) after test of hygrothermal behaviour.

### 2.2.14 Freeze-thaw behaviour

The freeze-thaw behaviour of the kit is to be carried out on test specimens by testing in accordance with the test method given in Annex E.

After the freeze-thaw behaviour test the following additional test is to be carried out on samples taken of the rig:

- Bond strength test (see Cl. 2.2.8).

The water absorption of both the base coat and the rendering system for freeze-thaw resistant kit is to be less than 0,5 kg/m<sup>2</sup> after 24 hours (see Cl. 2.2.4).

The freeze-thaw resistance of the kit is evaluated as to be satisfactory, if following defects shall occur neither during nor after the test of hygrothermal behaviour:

- Deterioration such as cracking or delamination of the rendering system that allows water penetration to the cladding element,
- Deterioration or cracking associated with joints between the cladding element,
- Detachment of the rendering system,
- Irreversible deformation,
- The particular value of bond strength after test of freeze/thaw behaviour is evaluated as to be satisfactory if:
  - The minimum failure bond strength value after test of freeze/thaw behaviour has to be at least 80 kPa with cohesive or adhesive rupture,or
  - The rupture occurs in the cladding element (cohesive rupture) if failure resistance is less than 80 kPa.

Characteristic value of bond strength after freeze/thaw cycles [kPa] as 95 % quartile on confidence level 75 % for  $V_x$  as unknown according to EN 1990, Annex D, Cl. 7.2 shall be calculated.

The following characteristics related to freeze/thaw resistance of the kit are given in the ETA:

- Water absorption of both the base coat and the rendering system after 24 hours,
- Characteristic value(s) of bond strength after freeze/thaw test,
- Description of the test specimen (its defects) after test of hygrothermal behaviour.

## **2.2.15 Resistance of subframe to corrosion (metallic subframe) and/or deterioration (wooden subframe)**

### **2.2.15.1 Resistance of metallic subframe and/or metallic parts of subframe to corrosion**

The corrosion protection of metal components is to be described according to the appropriate EN standard (e.g. EN ISO 3506-1, EN 1670, etc.)

The choice of steel, aluminium and stainless steel grade is to be described according to the appropriate EN standards (e.g. EN 10346 for continuously hot-dip coated steel, EN 755 and EN 1999-1-1 for aluminium alloys, EN 10088 for stainless steels, etc.).

The steel or aluminium grade, the respective corrosion protection and the corrosivity of atmospheres specified in EN ISO 9223 (e.g. marine atmosphere, industrial atmosphere, etc.) are to be described in function of the field of application.

The field of application of metal subframe as category of corrosivity of atmosphere according to EN ISO 9223 is/are given in the ETA.

### **2.2.15.2 Resistance of wooden parts of subframe to deterioration**

Wooden profiles treated by biocide preservatives are to be marked by the "PT" mark (treated with wood preservatives) as specified in EN 13986, Cl. 7.

If necessary, test according to EN 351-1 in respect to EN 350-2, EN 351-2 and EN 599-1 for the protection of wood profiles against attack by wood-destroying and wood-disfiguring fungi, insects and marine organisms is to be performed.

Type of wood preservative(s) used in the kit, and its/their classification according to EN 599-2 and the field of application of metal parts used in the kit combined from wooden and metal parts as category of corrosivity of atmosphere according to EN ISO 9223 (see 2.2.14.2) is/are given in the ETA.

*Note: The existing notified regulations in the European Union are: Regulation (EC) No. 1907/2006 (repealing Council Directive 76/769/EEC), Directive 98/8/EC (the BPR - 528/2012/EU), Decision 2007/565/EC.*

### 3 ASSESSMENT AND VERIFICATION OF CONSTANCY OF PERFORMANCE

#### 3.1 System(s) of assessment and verification of constancy of performance to be applied

For the products covered by this EAD the applicable European legal act is: Decision 2003/640/EC

The system is: **2+**

In addition, with regard to reaction to fire for products covered by this EAD the applicable European legal act is: Decision 2003/640/EC

The systems are: **1, 3 or 4** (depending on the class of reaction to fire according to Regulation (EU) No. 2016/364 and EN 13501-1)

Interpreting the footnotes in the aforementioned EC decision system 1 shall always apply in case of classes A1 to C, because for obtaining one of these classifications the addition of the flame retardants to (or the limitation of organic material in) the form mass is necessary.

#### 3.2 Tasks of the manufacturer

The cornerstones of the actions to be undertaken by the manufacturer of the product in the procedure of assessment and verification of constancy of performance are laid down in Table 2.

The actions to be undertaken by the manufacturer of the product for the different components of the kit are laid down in Tables 3, 4 and 5 when the components are produced by the manufacturer himself and Table 6 when the components are not produced by the manufacturer himself but by its supplier under the specifications of the manufacturer.

**Table 2 Control plan for the manufacturer; cornerstones.**

No	Subject/type of control	Test or control method (*)	Criteria, if any	Minimum number of samples	Minimum frequency of control
<b>Factory production control (FPC)</b>					
1	Components produced by the manufacturer himself				
	Base coat, key coat, finishing coat, decorative coat	See Table 3	According to the values specified by the manufacturer	See Table 3	See Table 3
	Reinforcement mesh	According to the relevant hEN standard or EAD	According to the values specified by the manufacturer	According to the relevant hEN standard or EAD	According to the relevant hEN standard or EAD
	Cladding element	See Table 4	According to the values specified by the manufacturer	See Table 4	See Table 4
	Cladding fixing and subframe components	See Table 5	According to the values specified by the manufacturer	See Table 5	See Table 5
	Thermal insulation	According to the relevant hEN standard	According to the values specified by the manufacturer	According to the relevant hEN standard	According to the relevant hEN standard

No	Subject/type of control	Test or control method (*)	Criteria, if any	Minimum number of samples	Minimum frequency of control
2	<u>Components not produced by the manufacturer itself</u> (**)	See Table 6	See Table 6	See Table 6	See Table 6
(*) In all cases, the TAB and the manufacturer may agree to alternative tests or control methods or, where none exist, these parties may agree on the method.					
(**) Components produced by the supplier under the specifications of the manufacturer.					

**Table 3 Control plan when the base coat, key coat, finishing coat and decorative coat are produced by the manufacturer itself; cornerstones.**

No	Subject/type of control	Test or control method (*)	Criteria, if any	Minimum number of samples	Minimum frequency of control
<b>Factory production control (FPC)</b>					
Base coat, key coat, finishing coat, decorative coat					
Incoming materials					
1	Receipt materials	Delivery ticket and/or label on the package Supplier certificates or supplier tests	Conformity with the order	--	Each delivery
2	Particle size grading	According to the prescription of the manufacturer	According to the prescription of the manufacturer	According to the prescription of the manufacturer	According to the prescription of the manufacturer
3	Bulk density				
Production process					
4	Mixing process	According to the prescription of the manufacturer	According to the prescription of the manufacturer	According to the prescription of the manufacturer	According to the prescription of the manufacturer
5	Packing				
Finishing materials					
6	Dry extract at 105 °C	According to the relevant hEN standard or EAD	According to the values specified by the manufacturer	According to test or control methods	According to Control Plan (**)
7	Volalite components at 450 °C				
8	Ash content at 900 °C				
9	Viscosity				
10	Apparent density				
11	pH value				
(*) In all cases, the TAB and the manufacturer may agree to alternative tests or control methods or, where none exist, these parties may agree on the method.					
(**) The frequency is determined case by case depending on the type of production process, the variation in the volume produced and the production process control.					



**Table 4 Control plan when the cladding element is produced by the manufacturer itself; cornerstones.**

No	Subject/type of control	Test or control method (*)	Criteria, if any	Minimum number of samples	Minimum frequency of control
<b>Factory production control (FPC)</b>					
Cladding element					
Incoming materials					
1	Receipt materials	Delivery ticket and/or label on the package Supplier certificates or supplier tests	Conformity with the order	--	Each delivery
Finishing components					
2	Geometry (form and dimensions)	When apply, according to the relevant hEN or EAD Otherwise measuring and visual check	According to the values specified by the manufacturer	According to test or control methods	According to Control Plan (**)
3	Density or mass per unit area or per unit	When apply, according to the relevant hEN or EAD			
4	Mechanical characteristics	When apply, according to the relevant hEN or EAD			
(*) In all cases, the TAB and the manufacturer may agree to alternative tests or control methods or, where none exist, these parties may agree on the method.					
(**) The frequency is determined case by case depending on the type of production process, the variation in the volume produced and the production process control.					

**Table 5 Control plan when the cladding fixing and subframe components are produced by the manufacturer itself; cornerstones.**

No	Subject/type of control	Test or control method (*)	Criteria, if any	Minimum number of specimens	Minimum frequency of control
<b>Factory production control (FPC)</b>					
<b>Cladding fixing and subframe components</b>					
Incoming materials					
1	Receipt materials	Delivery ticket or label on the package Supplier certificates or supplier tests	Conformity with the order	---	Each delivery
<b>Finished component</b>					

No	Subject/type of control	Test or control method (*)	Criteria, if any	Minimum number of specimens	Minimum frequency of control
1	Geometry (form and dimensions)	Measuring and visual check	According. to the values specified by the manufacturer	According to tests or control methods	According. to Control Plan (**)
2	Mechanical characteristics	Test or control based on relevant Cl.2.2.8 to Cl.2.2.9			
		Test according. to Cl. 2.2.7 to 2.2.9			
<p>(*) In all cases, the TAB and the manufacturer may agree to alternative tests or control methods or, where none exist, these parties may agree on the method.</p> <p>(**) The frequency is determined case by case depending on the type of production process, the variation in the volume produced and the production process control.</p>					

**Table 6 Control plan when components are not produced by the manufacturer; cornerstones.**

No	Subject/type of control	Test or control method (**)	Criteria, if any	Minimum number of specimens	Minimum frequency of control
<b>Factory production control (FPC)</b>					
1	Components belonging to Case 1 (*)	(1)	Conformity with the order	Testing is not required	Each delivery
		(2)	Acc. to the manufacturer specifications	Testing is not required	Each delivery
2	Components belonging to Case 2 (*):	(1)	Conformity with the order	Testing is not required	Each delivery
	▪ Characteristics declared in DoP for the specific use within the kit.	(2)	Acc. to the manufacturer specifications	Testing is not required	Each delivery
	▪ Characteristics not declared in DoP for the specific use within the kit.	(3)	Acc. to the manufacturer specifications	Acc. to Control Plan	Acc. to Control Plan
3	Components belonging to Case 3 (*):	(1)	Conformity with the order	Testing is not required	Each delivery
		(3)	Acc. to the manufacturer specifications	Acc. to Control Plan	Acc. to Control Plan
<p>(1) Checking of delivery ticket and/or label on the package.</p> <p>(2) Checking of technical data sheet and DoP or, when relevant: supplier certificates or supplier tests or test or control acc. to tables 3.1a to 3.1c above.</p> <p>(3) Supplier certificates or supplier tests or Test or control acc. to tables 3.1a to 3.1c above.</p> <p>(*) Case 1: Component covered by a hEN or its own ETA for all characteristics needed for the specific use within the kit. Case 2: If the component is a product covered by a hEN or its own ETA which, however, does not include all characteristics needed for the specific use within the kit. Case 3: The component is a product not (yet) covered by a hEN or its own ETA.</p> <p>(**) In all cases, the TAB and the manufacturer may agree to alternative tests or control methods or, where none exist, these parties may agree on the method.</p>					

### 3.3 Tasks of the notified body

The cornerstones of the actions to be undertaken by the notified body in the procedure of assessment and verification of constancy of performance for product for system 1, concerning only of performance “reaction to fire”, are laid down in Table 7.

The involvement of the notified body is required only under the conditions defined in 1999/91/EC amended by 2001/596/EC - in case of reaction to fire class A1, A2, B, C of the product for which a clearly identifiable stage in the production process results in an improvement of the reaction to fire classification (e.g. an addition of fire retardants or a limiting of organic material) as specified in Regulation (EU) No. 2016/364 and EN 13501-1 on the classification of the reaction to fire performance of construction products.

**Table 7 Control plan for the notified body; cornerstones**

No.	Subject/type of control ( <i>product, raw/constituent material, component</i> - <i>indicating characteristic concerned</i> )	Test or control method	Criteria, if any	Minimum number of samples	Minimum frequency of control
<b>Initial inspection of the manufacturing plant and of factory production control</b>					
1	<p>The notified body shall verify the ability of the manufacturer for a continuous and orderly manufacturing of the product. In particular, the following items shall be appropriately considered</p> <ul style="list-style-type: none"> <li>– personnel and equipment</li> <li>– the suitability of the factory production control established by the manufacturer</li> <li>– full implementation of the prescribed test plan.</li> </ul>		As defined in clause 2.2.1 of the EAD		--
<b>Continuous surveillance, assessment and evaluation of factory production control</b>					
2	<p>The notified body shall verify</p> <ul style="list-style-type: none"> <li>– the manufacturing process</li> <li>– the system of factory production control</li> <li>– the implementation of the prescribed test plan are maintained.</li> </ul>		As defined in clause 2.2.1 of the EAD		1/year

## 4 REFERENCE DOCUMENTS

As far as no edition date is given in the list of standards thereafter, the standard in its current version at the time of issuing the European Technical Assessment, is of relevance.

Regulation (EC) No. 1907/2006 of the European Parliament and of the Council of 18 December 2006 concerning the Registration, Evaluation, Authorisation and Restriction of Chemicals (REACH), establishing a European Chemicals Agency as amended

Regulation (EU) No. 528/2012 of the European Parliament and of the Council of 22 May 2012 concerning the making available on the market and use of biocidal products

Commission Delegated Regulation (EU) No. 2016/364 of 1 July 2015 on the classification of the reaction to fire performance of construction products pursuant to Regulation (EU) No. 305/2011 of the European Parliament and of the Council

EN 350-2, Durability of wood and wood-based products - Natural durability of solid wood - Part 2: Guide to natural durability and treatability of selected wood species of importance in Europe

EN 351-1 Durability of wood and wood-based products - Preservative-treated solid wood - Part 1: Classification of preservative penetration and retention

EN 351-2, Durability of wood and wood-based products - Preservative-treated solid wood - Part 2: Guidance on sampling for the analysis of preservative-treated wood

EN 599-1, Durability of wood and wood-based products - Performance of preventive wood preservatives as determined by biological tests - Part 1: Specification according to hazard class.

EN 599-2 Durability of wood and wood-based products - Performance of preventive wood preservatives as determined by biological tests - Part 2: Classification and labelling

EN 755 Aluminium and aluminium alloys - Extruded rod/bar, tube and profiles

EN 1015-12 Methods of test for mortar for masonry - Part 12: Determination of adhesive strength of hardened rendering and plastering mortars on substrates

EN 1670 Building hardware - Corrosion resistance - Requirements and test methods

EN 1990 Eurocode: Basis of structural design

EN 1993-1-1 Eurocode 3: Design of steel structures - Part 1-1: General rules and rules for buildings

EN 1995-1-1 Eurocode 5: Design of timber structures - Part 1-1: General - Common rules and rules for buildings

EN 1999-1-1 Eurocode 9: Design of aluminium structures - Part 1-1: General structural rules

EN 10088 Stainless steels

EN 10346 Continuously hot-dip coated steel flat products for cold forming - Technical delivery conditions

EN 12467 Fibre-cement flat sheets - Product specification and test methods

EN 13162 Thermal insulation products for buildings - Factory made mineral wool (MW) products - Specification

EN 13238 Reaction to fire tests for building products - Conditioning procedures and general rules for selection of substrates

EN 13501-1 Fire classification of construction products and building elements - Part 1: Classification using test data from reaction to fire tests

EN 13823 Reaction to fire tests for building products - Building products excluding floorings exposed to the thermal attack by a single burning item

EN 13956 Flexible sheet for waterproofing - Plastic and rubber sheets for roof waterproofing - Definitions and characteristics

EN 13986 Wood-based panels for use in construction - Characteristics, evaluation of conformity and marking

EN 14081-1 Timber structures - Strength graded structural timber with rectangular cross section - Part 1: General requirements

EN 14195 Metal framing components for gypsum board systems - Definitions, requirements and test methods

EN 15228 Structural timber - Structural timber preservative treated against biological attack

EN 16516 Construction products: Assessment of release of dangerous substances. Determination of emissions into indoor air

EN ISO 1182 Reaction to fire tests for products - Non-combustibility test

EN ISO 1716 Reaction to fire tests for products - Determination of the cross heat of combustion (calorific value)

EN ISO 3506-1 Mechanical properties of corrosion-resistant stainless steel fasteners - Part 1: Bolts, screws and studs

EN ISO 6341 Water quality - Determination of the inhibition of the mobility of *Daphnia magna* Straus (Cladocera, Crustacea) - Acute toxicity test

EN ISO 6946 Building components and building elements - Thermal resistance and thermal transmittance - Calculation method

EN ISO 7500-1 Metallic materials - Verification of static uniaxial testing machines - Part 1: Tension/compression testing machines - Verification and calibration of the force-measuring system

EN ISO 8990 Thermal insulation - Determination of steady state thermal transmission properties - Calibrated and guarded hot box

EN ISO 9223 Corrosion of metals and alloys - Corrosivity of atmospheres - Classification, determination and estimation

EN ISO 10140-1 Acoustics - Laboratory measurement of sound insulation of building elements - Part 1: Application rules for specific products

EN ISO 10140-2 Acoustics - Laboratory measurement of sound insulation of building elements - Part 2: Measurement of airborne sound insulation

EN ISO 10140-4 Acoustics - Laboratory measurement of sound insulation of building elements - Part 4: Measurement procedures and requirements

EN ISO 10140-5 Acoustics - Laboratory measurement of sound insulation of building elements - Part 5: Requirements for test facilities and equipment

EN ISO 10211 Thermal bridges in building construction - Heat flows and surface temperatures - Detailed calculations

EN ISO 10456 Building materials and products - Hygrothermal properties - Tabulated design values and procedures for determining declared and design thermal values

EN ISO 11348-1 Water quality - Determination of the inhibitory effect of water samples on the light emission of *Vibrio fischeri* (Luminescent bacteria test) - Part 1: Method using freshly prepared bacteria

EN ISO 11348-2 Water quality - Determination of the inhibitory effect of water samples on the light emission of *Vibrio fischeri* (Luminescent bacteria test) - Part 2: Method using liquid-dried bacteria

EN ISO 11348-3 Water quality - Determination of the inhibitory effect of water samples on the light emission of *Vibrio fischeri* (Luminescent bacteria test) - Part 3: Method using freeze-dried bacteria

EN ISO 11925-2 Reaction to fire tests - Ignitability of building products subjected to direct impingement of flame - Part 2: Single-flame source test

EN ISO 13943 Fire safety – Vocabulary

EN ISO 13788 Hygrothermal performance of building components and building elements - Internal surface temperature to avoid critical surface humidity and interstitial condensation - Calculation methods

ISO 13785-1 Reaction-to-fire tests for façades – Part 1: Intermediate-scale test

ISO 13785-2 Reaction-to-fire tests for façades -- Part 2: Large-scale test

ISO 15799 Soil quality -- Guidance on the ecotoxicological characterization of soils and soil materials

CEN/TS 16637-2:2014 Construction products - Assessment of release of dangerous substances - Part 2: Horizontal dynamic surface leaching test

OECD Test Guideline 301 Ready biodegradability, part A, B or E

EOTA Technical Report TR 001 Determination of impact resistance of panels and panel assemblies

EOTA TR 034 Construction products: Assessment of release of dangerous substances. Determination of emissions into indoor air, October 2015

ETAG 004 External thermal insulation composite systems (ETICS) with rendering

ETAG 034 Kits for external wall claddings

## ANNEX A REACTION TO FIRE

This Annex is based on Annex D of ETAG 004 (2013).

### A.1 Rules for choosing that components and their relevant parameters to be considered in the relevant reaction to fire tests

#### A.1.1 General

##### *Principle*

The determination of reaction to fire of the kit is based on testing of “the critical case” – the most critical configuration in sense of reaction to fire. According to rules described further in the text, the classification obtained on the most critical configuration of the kit is valid for all configurations having better performance in sense on reaction to fire

For the particular types of kit components, the following principles apply:

- The cladding element, base coat, key coat, finishing coat, decorative coat and flexible sheet for waterproofing with the highest amount of organic content (related to the mass in dried condition as in end use application) or the highest PSC value (according to EN ISO 1716)<sup>4</sup> shall be used for preparing the specimen
- Each decorative coat, key coat and flexible sheet for waterproofing shall be tested unless it can be neglected according to the rules below. If there are only differences in the amount of organic content but no difference in the organic component itself, The decorative coat, key coat and flexible sheet for waterproofing with the highest organic content or the highest  $Q_{PCSS}$  value (according to EN ISO 1716)<sup>4</sup> of this organic component shall be tested,
- The decorative coat, key coat and flexible sheet for waterproofing can be neglected as long as they comply with the following<sup>5</sup>.
  - The thickness of the coat is less than 200  $\mu\text{m}$ ,
  - And the content of organic components is of not more than 5 % (related to the mass in dried condition as in end use application).
- In addition, cladding element, and each coat selected for testing according to the rules before shall have the lowest amount of flame retardants.

##### *Product properties influencing the reaction to fire behaviour*

- Type of cladding element (composition, thickness, density),
- Type of thermal insulation (composition, thickness, density),
- Type of flexible sheets for waterproofing (composition, thickness, mass per unit area),
- Type of base coat and finishing coats (composition, thickness, mass per unit area),
- Type of key coats and decorative coats (composition, mass per unit area),
- Type of reinforcement (composition, thickness, mass per unit area),
- Type and nature of fixing devices,
- Type and nature of subframe.
- The organic content of the binder and of any organic additive; this can be checked by providing the formulation of the component, by performing suitable identification tests or by determining the glow loss or net calorific value

<sup>4</sup> The manufacturer is responsible for the information on organic content per unit area. If the information is not available, the  $Q_{PCSS}$  value is tested to decide about the critical case.

<sup>5</sup> This rule can be reconsidered when more experience and test result are available

- Type and nature of fire breaks (interruptions to the continuity of insulation or any cavity)<sup>6</sup>
- Type and amount of flame retardant intended to maintain or improve the reaction to fire performance of the kit or kit components and consequently of building elements to which they are applied.

Although the rest of this annex applies the “critical case scenario” for deciding what to test, it is accepted that, where the manufacturer produces a range of kit having different overall classifications, he may group these together into a number of different sub-groups (e.g. each sub-group corresponding to a different overall classification) with the ‘critical case scenario’ being identified for each sub-group.

Kit components where these require separate assessment (as opposed to being tested as part of the kit as a whole), which are classified A1 without testing according to Decision 96/603, as amended, do not need to be tested.

### **A.1.2 Testing according to EN ISO 1182**

This test method is relevant for classes A1 and A2.

Using this test method, only the ‘substantial components’ of the kit need to be tested. ‘Substantial components’ are defined by thickness ( $\geq 1$  mm) and/or mass per unit area ( $\geq 1$  kg/m<sup>2</sup>).

In the following, the cladding element, the thermal insulation, the base coat and the finishing coat are identified as the most significant ‘substantial components’, but the key coat, the decorative coat, flexible sheet for waterproofing and any reinforcement mesh may also be ‘substantial components’.

Parameters relevant for this test method are:

- Composition,
- Density or mass per unit area,
- Thickness.

#### **A.1.2.1 Thermal insulation, cladding element**

For the kit expected to be classified as A1 or A2, it is anticipated that only products with reaction to fire class A1 or A2 will form the kit. For testing the thermal insulation and cladding element reference shall be made to the relevant product standards or other relevant documents.

#### **A.1.2.2 Rendering system**

##### **A.1.2.2.1 Base coats and finishing coats**

The reaction to fire behaviour of base coats and finishing coats not falling under EC Decision 96/603/EC (as amended) shall be tested according to the principle specified in Cl. General.

The test result can be directly applied to all variants with the same base coat and finishing coat and with a lower amount of organic components. When the subject of the directly applied result contains a flame retardant, it shall be of the same type and its content shall be at least that of the product tested.

Differences concerning the density shall be considered by testing the lowest and the highest density.

##### **A.1.2.2.2 Key coats, decorative coats**

The principles specified in Cl. A.1.1 “Principle” shall be applied.

---

<sup>6</sup> Fire breaks are important for the behaviour of the whole facade cladding system and cannot be assessed on the basis of SBI-testing. The influence can only be observed during a large scale test. Therefore, breaks are not included in the mounting and fixing rules for the SBI-test. A European fire scenario for facades has not been laid down. An additional assessment according to national provisions (e.g. on the basis of examining design solutions or a large scale test) might be necessary to comply with Member State regulations, until the existing European classification system has been completed.



### **A.1.2.2.3 Reinforcement mesh**

Each type of reinforcement mesh that fulfils the requirements of a 'substantial components' shall be tested according to EN ISO 1182. Reinforcement mesh that is randomly dispersed (e.g. fibres) in the rendering system shall be tested as part of the rendering system.

### **A.1.2.3 Flexible sheet for waterproofing**

The principles specified in Cl. A.1.1 "Principle" shall be applied

### **A.1.3 Testing according to EN ISO 1716 ( $Q_{PCSS}$ value)**

This test method is relevant for classes A1 and A2.

This test method shall be performed to all kit components except for cases, which are classified as A1 without testing.

Parameters relevant for this test method are: composition (when performing calculation of the  $Q_{PCSS}$ -value), density or mass per unit area and thickness. Mechanical fixing devices and ancillary materials which are not continuous but discrete kit components do not need to be considered for testing and for the calculation of the  $Q_{PCSS}$ .

#### **A.1.3.1 Thermal insulation**

For testing the thermal insulation, reference shall be made to the relevant product standards or other related documents.

It is not realistic to require that each thermal insulation of the same type is tested within the classification of a kit. If the thermal insulations come from different manufacturers and/or are of different thickness, density and formulation from those used in the testing, these may be used subject to the requirements of class A1 and A2 still being fulfilled. It shall be proved by calculation (undertaken by an Technical Assessment Body or Notified Body) that the kit, together with the actual thermal insulation used in end use application, still fulfils the requirements concerning the  $Q_{PCSS}$ -value of the whole product. For example, it is sufficient to determine the  $Q_{PCSS}$ -value of the mineral wool and if this is lower than the originally tested product then it is acceptable to use the alternative mineral wool instead of that used in the original test.

Note: information relating to alternative thermal insulation of the same type to the originally tested may be evaluated on basis of the supplier's evidence provided within the context of its CE marking.

#### **A.1.3.2 Cladding element**

Each type of cladding element shall be tested according to EN ISO 1716.

The test shall be performed in accordance with the principles specified in Cl. A.1.1 General.

#### **A.1.3.3 Rendering system**

In general, when performing calculations of the unit area referred  $Q_{PCSS}$ -value (related to the surface) the variant that provides the highest  $Q_{PCSS}$ -value shall be considered.

The test shall be performed in accordance with the principles specified in Cl. A.1.1 General applied to each component of the rendering system.

It is not necessary to test a finishing coat with different grain sizes if the organic content is the same as or lower than that of the tested coat.

The test results can be directly applied to all variants with the same rendering system but with a lower amount of organic components. When the subject of the directly applied result contains a flame retardant, it shall be of the same type and its content shall be at least that of the product tested.

#### **A.1.3.4 Reinforcement mesh**

Each type of reinforcement mesh shall be tested according to EN ISO 1716. For reinforcement mesh that is randomly dispersed (e.g. fibres) in the rendering system it shall be tested as part of the rendering system.

### **A.1.3.5 Flexible sheet for waterproofing**

Each type of flexible sheet for waterproofing shall be tested according to EN ISO 1716.

The test shall be performed in accordance with the principles specified in Cl. A.1.1 General.

### **A.1.4 Testing according to EN 13823 (SBI-test)**

This test method is relevant for the classes A2, B, C and D (in some cases also to A1).

In this test procedure the complete kit shall be tested. The kit is fixed to a substrate representing that on which the kit is fixed in the end use application (reference is made to EN 13238). The fixing shall be made by using the means of mechanical fixing used in the end use application.

According to EN 13238, the maximum testable thickness of the test specimen, including a standard substrate is 200 mm. However, in practice, for many kits, the total overall thickness may be greater than 200 mm. In such cases, using a standard substrate, the thickness of the substructure and the thermal insulation shall be reduced to provide for a maximum specimen thickness of 200 mm. Results obtained on an kit at 200 mm thickness are accepted for greater thicknesses.

The test specimen consists of a corner construction, which shall be representative of the construction in practice. All edges are covered with the rendering system excluding the bottom edge and the top of the specimen. The floor of the test trolley beneath the test specimen can be covered by an aluminium foil.

It is recommended to either prepare the specimens at the lab and then put it onto the trolley (with the foil on), or manufacturer builds the wall at the factory and carries it to the lab where it is put onto the trolley. After preparation of the test specimens, they shall be conditioned according to EN 13238.

Parameters, which are relevant for this test method:

- Type, thickness and density of the thermal insulation,
- Type, thickness and density of the cladding element,
- Type, binder and thickness of each coat of rendering system,
- Amount of organic content of each coat of render system,
- Amount of flame retardant of each coat of render system,
- Type of reinforcement mesh.

In principle, it is desirable to find the test specimen configuration that gives the critical case concerning the reaction to fire test results. In the test procedure according to EN 13823, values for the rate of heat release, total heat release, lateral flame spread, rate of smoke release, total smoke release and burning droplets are determined.

The mounting and fixing provisions of SBI tests are defined in Cl. A.2.

#### **A.1.4.1 Thermal insulation**

For the testing of kit with thermal insulation with the highest thickness, highest density (with a tolerances of  $\pm 10\%$ ) and the highest organic content (related to the mass in dried condition) has to be used for preparing the test specimen. The reaction to fire of the thermal insulation shall be proven separately.<sup>7</sup>

#### **A.1.4.2 Cladding element**

Each type of cladding element shall be tested according to EN 13823.

The test shall be performed in accordance with the principles specified in Cl. A.1.1 General.

---

<sup>7</sup> In some Member States requirements might exist to demonstrate the behaviour of products with respect to continuous glowing combustion in the case of fire. The mandates for the product standards, therefore, are currently under revision. Additional national assessment e.g. on the basis of national procedures to demonstrate this behaviour might be required until a European harmonized procedure is available.

#### **A.1.4.3 Rendering system**

By testing one specific rendering system representing a range of different coats, the following rules shall applied to discriminate the composition, which is able to represent a range of coats):

- The base coat, the key coat, the finishing coat and decorative coat to be used for preparing the specimen, taking account of the permissible combinations allowed by the manufacturer, shall be determined in accordance with the principles specified in A.1.1 General.
- For a base coat and a finishing coat having an organic content less than or equal to 5 % (related to the mass in dried condition as used in the end use application), only the lowest thickness needs to be used for preparing the test specimen.
- For a base coat or finishing coat having an organic content higher than 5 %, both the lowest and the highest thickness of the layer of the base coat and finishing coat shall be used for preparing the test specimens.

Regardless of the organic content, only the highest thickness of a base coat and a finishing coat shall be tested on thermal insulation with class A1 or A2-s1,d0.

When the only difference in coatings is thickness and it is 0,5 mm or less, the coatings may be considered to be the same.

#### **A.1.4.4 Reinforcement mesh**

The specimens shall be prepared with the reinforcement mesh that is intended to be used in end use application. If different reinforcement meshes are intended to be used, the reinforcement mesh with the highest  $Q_{PCSS}$ -value per unit area shall be used for preparing the SBI specimen. At the long wing of the SBI specimens a vertical joint of the reinforcement mesh shall be included at a distance of 200 mm away from the inner corner of the specimens by 100 mm overlapping of the two layers of the reinforcement mesh (that means the joint begins at a distance of 150 mm and ends at a distance of 250 mm away from the inner corner). The test results from a system with an overlap of the reinforcement of 100 mm are valid for all joints with an overlapping of 100 mm or more.

#### **A.1.4.5 Flexible sheet for waterproofing**

Each type of flexible sheet for waterproofing shall be tested according to EN 13823.

The test shall be performed in accordance with the principles specified in Cl. A.1.1 General.

#### **A.1.4.6 Extension of results**

The results of SBI test shall be extended according to Cl. A.3.1 and Cl. A.3.2.1

#### **A.1.5 Testing according to EN ISO 11925-2**

This test method is relevant for classes B, C, D and E.

In this test procedure, the kit is tested without using a subframe, thermal insulation and a flexible sheet for waterproofing. The maximum thickness of test specimen is 60 mm. In cases where the thickness of the test specimen (cladding element, rendering system and reinforcement mesh) is larger than 60 mm, the cladding element may be reduced for the purposes of testing. The results from the testing of specimens at 60 mm are applicable to greater thicknesses.

Parameters which are relevant:

- Type, thickness and density of cladding element,
- Type, binder and thickness of each coat of render system,
- Amount of organic content of each coat of render system,
- Amount of flame retardant of each coat of render system,
- Type of reinforcement mesh,

The specimens are prepared in such a way that the edges are not covered with the rendering system (cut edges). The tests are performed with surface flaming of the front side and possibly edge flaming of the test specimen turned by 90° according to the rules of standard EN ISO 11925-2.

#### **A.1.5.1 Cladding element**

A cladding element, representative in its characterization (type, reaction to fire classification and density) for the end use application shall be used. The kit shall be evaluated incorporating the cladding element at the highest possible thickness and the highest and the lowest possible densities.

#### **A.1.5.2 Rendering system**

For testing one specific rendering system representing a range of different coats, the rules as mentioned in Cl. A.1.4.3 apply.

#### **A.1.5.3 Reinforcement mesh**

The specimen shall be prepared with the reinforcement mesh intended to be used in end use application. If different reinforcement meshes are intended to be used, the reinforcement mesh with the highest PSC<sub>s</sub>-value per unit area has to be tested.

#### **A.1.5.4 Extension of results**

The results test shall be extended according to Cl. A.3.1 and Cl. A.3.2.2.

### **A.2 Mounting and fixing provisions for the SBI-test**

The reaction to fire testing shall be given for the entire kit, in simulating its end use conditions.

The testing standard EN 13823 Reaction to fire tests for building products – Building products excluding floorings exposed to the thermal attack by a single burning item gives a general description of the arrangement of the test specimen for SBI-test, applicable to classes A2, B, C and D (in some cases also to A1)

This clause describes specific provisions for kits with renderings applied in situ.

#### **A.2.1 General information**

##### **A.2.1.1 Testing of front side of the kit**

As a function of the intended use of the kit, the specimen shall be installed on a substrate in accordance with standard EN 13238:

The frame is made from non fire-retardant treated timber, aluminium or steel.

All the components which form part of the kit (e.g. optional waterproofing layer) shall be included in a representative fashion in the test specimen.

An air gap is always provided behind the cladding element. The critical width of ventilated air gap is to be tested and classified. The critical width of ventilated air gap is chosen as follows:

- If the manufacturer specifies the width of ventilated air gap greater or equal 40 mm, the critical width is 40 mm

or

- If the manufacturer specifies the width of ventilated air gap less than 40 mm, the critical width is according to manufacturer's specification but the minimum 20 mm.

For ensuring realistic ventilation inside the air gap behind the cladding element the bottom and top edges of the test specimens shall also remain open.

If the mineral wool insulation layer (optional) is planned in end use situation of the kit, a 50 mm thick insulation product made of mineral wool according to EN 13162, with a density of 70 to 150 kg/m<sup>3</sup>, shall be installed between frame and substrate.

The cladding elements are fixed to the frame. The kit shall be installed with fixing devices density defined by the manufacturer.

Rendering systems shall be applied following considerations included in Cl.A.1.4.

The kit shall be tested with a horizontal joint in the long wing at a height of 500 mm from the bottom edge of the specimen and with vertical joint in the long wing at distance of 200 mm from the corner line, in accordance with the following Figure A.1. In the areas A, B, C, D and E, it is possible to have other vertical and/or horizontal joints between cladding element, if their size is not big enough.

In the internal vertical angle, no profile shall be used and the cladding elements with the rendering systems create a vertical close joint.

#### A.2.1.2 Testing of rear side of the kit in ventilated air gap

Due to asymmetry, rear side of the kit in ventilated air gap may require to be tested and classified independently according to the provisions of EN 13501-1. When tested according to the SBI test (EN 13823), it necessitate a free-hanging arrangement with the flame impingement to the rear side in accordance with EN 13823, Cl. 5.2.2 (test arrangement without open joints between cladding elements, and without insulation layer on A1 or A2 substrate, so that the distance between the substrate and cladding element amounts to at least 80 mm). All components which form part of the kit (e.g. optional waterproofing layer) shall be included in a representative fashion in the test specimen of the rear side.

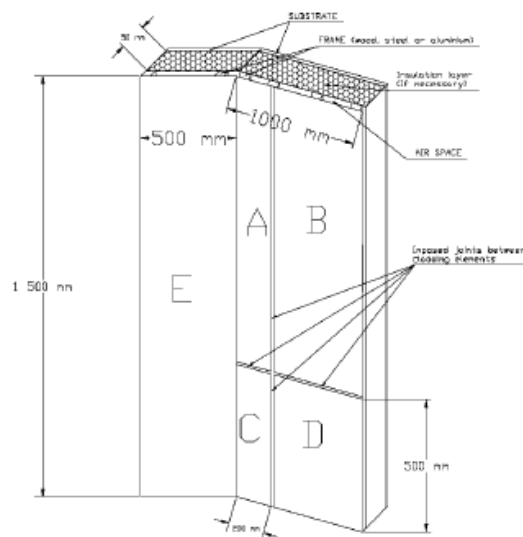

Figure A.1 – Example of SBI test installation

#### A.2.2 Specific information

The kits are tested in a limited number of configuration to cover the influence of the following parameters, for instance, lower and higher thickness of cladding elements, type of the fixings or maximum density of the fixings.

The cladding elements can be cut to size as shown in Figure A.2.

The products are fixed to the frame by through fixing.

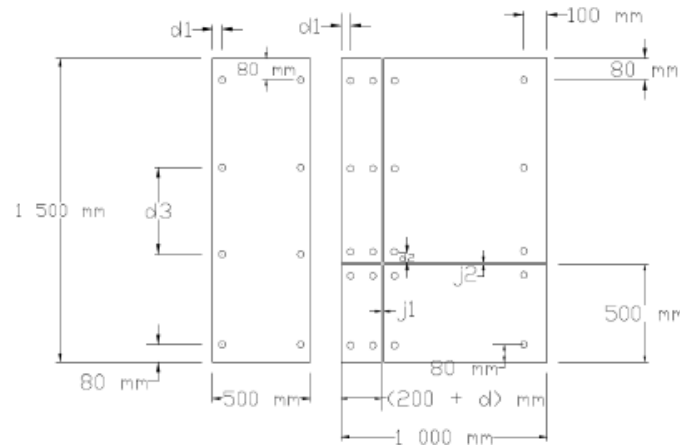

Figure A.2 – Example of installation

### A.3 Rules for the direct and extended application of the test results

#### A.3.1 General

Where relevant, direct application rules relating to reaction to fire shall be according to appropriate harmonized EN standard or ETA.

##### A.3.1.1 General application rules for extending results of the components tested accordance to EN 13823 (SBI-test)

The test results of components according to EN 13823 shall remain valid without test:

- For a higher density of fixing devices,
- For all other greater thicknesses of mineral wool insulation layer with the same density and the same or better reaction to fire classification, if the kit has been tested with mineral wool insulation layer,
- For other higher thickness of air space.

Additional direct application rules for the kit components shall be according to Cl. A.3.2

#### A.3.2 Direct application rules for components

##### A.3.2.1 Extending results according to EN 13823

The test results are valid for:

##### Thermal insulation

- Of the same type,
- With lower density,
- With lower thickness or between those evaluated in the tests, provided that the worst result of the two thicknesses tested is used for intermediate thicknesses,
- With equal or less organic content.

##### Cladding element

- Extending results according to EN 12467, Cl. 7.5.2.2.5,
- With equal or less organic content,
- With equal or greater content of the same type of flame retardants,
- With equal or greater thickness if the organic content is equal to or less than 5 %,
- With thickness between those evaluated in the tests, if the organic content is higher than 5 %,
- For greater dimensions of the cladding element.

**Base coats and finishing coats**

- With equal or less organic content,
- With equal or greater content of the same type of flame retardants,
- With equal or greater thickness if the organic content is equal to or less than 5 %,
- Base coat and finishing coat having more than 5 % organic content:
- With thickness between those evaluated, provided that the worst results of the two thickness tested is used for intermediate thicknesses.

**Key coats**

- With equal or less organic content per unit area,
- With equal or less organic content,
- With equal or greater content of the same type of flame retardants.

**Decorative coats**

- With equal or less organic content per unit area,
- With equal or greater content of the same type of flame retardants.

**Reinforcement mesh**

- With equal or lower PSC<sub>s</sub>-value per unit area.

**Flexible sheet for waterproofing**

- Of the same type,
- With lower weight per unit area,
- With equal or less organic content,
- With equal or greater thickness if the organic content is equal to or less than 5 %.

**A.3.2.2 Extending results according to EN ISO 11925-2**

The test result covers and use application arrangements with thicknesses and densities between those evaluated in tests and equal or less organic content.

For the extended application of test results regarding to base coat, finishing coat, key coat, decorative coat, reinforcement mesh and cladding element, the same rules shall apply as given in section A.1.5.4.

## **ANNEX B WIND LOAD RESISTANCE OF THE SYSTEM**

This test method is based on test method indicated in the Cl. 5.4.1 of ETAG 034 part 1 (April 2012).

The principle is to establish the effects of suction and pressure loads on the kit.

The number of tests depends on the combination of parameters presented for the kit.

As a minimum, the mechanical weakest design shall be tested.

### **B.1 Wind suction test**

#### **B.1.1 Preparation of the test specimen**

The test specimen shall be mounted in the test equipment in accordance with the manufacturer instructions.

The test specimen is defined as follows:

- A non airtight substrate (test rig) such as wooden or steel rigid frame or masonry or concrete wall with one hole per square meter, with a diameter at least 15 mm,
- The kit shall be fixed to the test rig,
- The dimension of the test specimen depends on the size of external cladding element and the specified cladding fixings:
  - For the cladding elements which are mechanically fixed independent of each other, a minimum surface cladding of 1,5 m<sup>2</sup> shall be tested,
  - If they depend on each other vertically and horizontally, at least 3 x 3 elements shall be tested,
  - If they depend on each other vertically or horizontally, at least 4 elements shall be tested.

To define the mechanically weakest design the following aspects shall be taken into account:

- The mechanically weakest cladding element (e.g. minimum thickness, minimum bending strength, etc.),
- Minimum density of cladding fixings,
- Maximum span between non-continuous subframe pieces.

The tolerances due to manufacturing and/or installation and deformations due to temperature and humidity variations have to be taken into account.

#### **B.1.2 Test equipment**

The test equipment consists of a pressure or suction chamber (see Figure B.1) against which is placed the kit. The depth of chamber shall be sufficient for a constant pressure or suction to be exerted on the test specimen applied to the external surface of the kit irrespective of its possible deformation. The chamber is mounted on a rigid frame. The kit acts as the seal between the chamber and the environment. The connection between the kit and the chamber shall be sufficient to allow a realistic deformation of the test kit under the influence of simulated wind suction.

#### Alternative test equipment

The alternative test may be used, provided that the geometric shape allows the foil bags to be placed in the air gap and be blown out so that a uniformly distributed pressure load at the rear face of the cladding is possible.

The test rig consists of a rigid frame (steel construction) made of vertical longitudinal girder and horizontal profiles (anchor channel) and rigid boards or a massive wall such as masonry or concrete.

The subframe of the cladding kit has to be fixed on the rig and the cladding elements have to be fixed on the subframe according to the indications given by the manufacturer.



The vertical profiles of the rig can be movable (sliding) so that they can be placed in the axis of the fixings of the cladding element.

Foil bags, which are placed in the air gap at the rear side of the cladding element are blown out and they exert a uniformly distributed pressure load on the rear face of the cladding which corresponds to the wind suction load.

### **B.1.3 Test procedure**

The uniformly distributed loads are exerted on the external surface of the kit.

The test is performed in successive steps (two steps of 300 Pa, one step to 500 Pa and then one step of 1000 Pa, then steps of +200 Pa thereafter, at each step the load is maintained constant for at least 10 seconds and returned to zero after each step; see Figure B.2), until significant irreversible deformation (deformation which affects serviceability).

The test is then continued until failure occurs.

The deflection shall be measured, at the relevant points (e.g. central point of the cladding element, border or corner of the cladding element, cladding fixing, profiles, etc.), as a function of the load and reported in tabular or graphic form.

With the differential pressure reduced to zero, the permanent deflection shall be noted after 1 minute recovery. The pressure at which defect or damage occur shall be noted.

Additionally, if relevant, the permanent deflection 1 hour after failure occurs shall be noted.

The fixings between the kit and the test equipment shall not constitute weak points and shall therefore be chosen accordingly.

### **B.1.4 Observations during the test**

The failure is defined by any one of the following events:

- Any cladding element breaks,
- Any cladding element presents a significant permanent deflection,
- The failure of fixings (e.g. pull out, deformation, breakage),
- The failure or detachment of the subframe of the kit.

Additionally, any crack on the exterior surface shall be observed and noted.

### **B.1.5 Test results**

The test result is:

- The failure load  $Q$ ,
- The type of failure,
- The value of maximum permanent deflection (after 1 minute recovery), the maximum deflection of the test specimen and the load and sensor position for this maximum permanent deflection and maximum deflection.

### **B.1.6 Test specimen description**

If is necessary to describe the test specimen by giving details about:

- Subframe (material properties, section, distance between the supports),
- Cladding element dimensions, joints compositions and cladding element fixing density,
- Fixing between the test equipment and the kit (position, generic type, material and geometry),

- Rendering system (finishing coat and base coat) if it is used.

**B.3 Wind pressure test**

The test procedure is similar to B.1, the only difference being that the wind action is reversed.

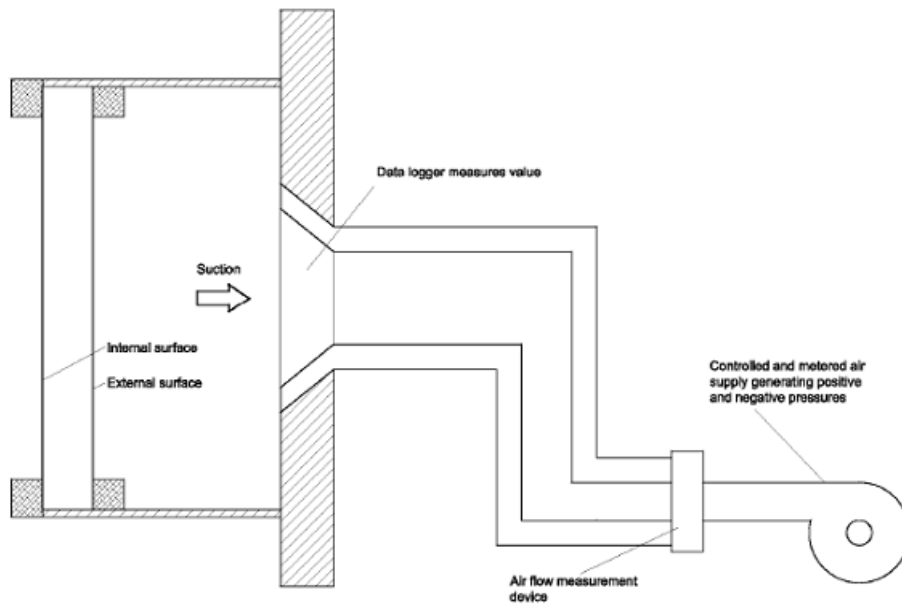

Figure B.1 – Example of wind pressure and suction apparatus

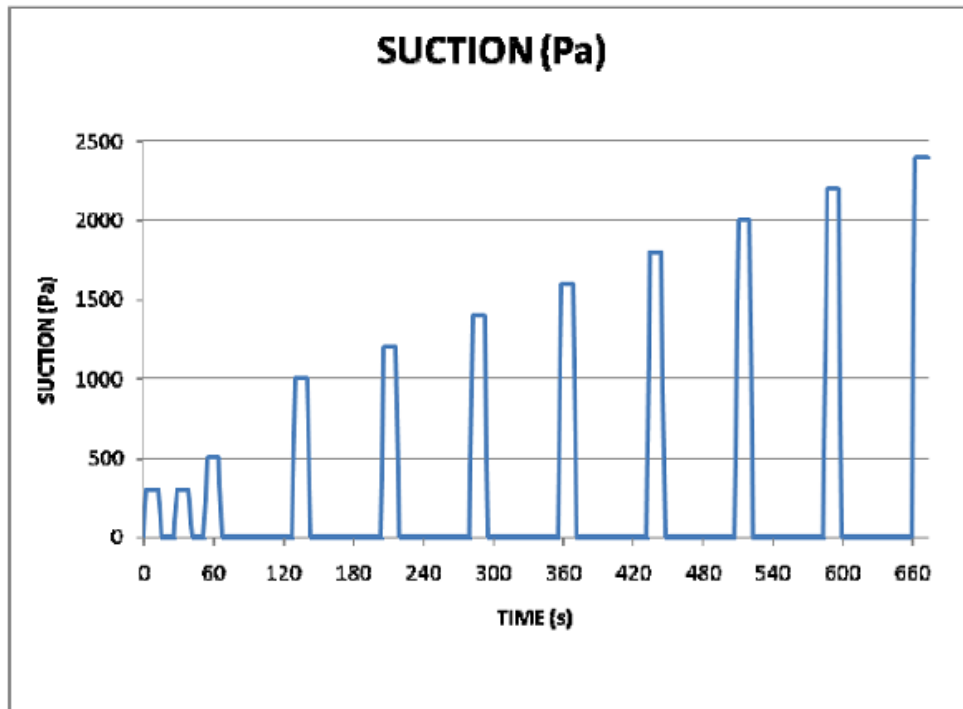

Figure B.2 – Example of wind load steps

## ANNEX C                    IMPACT RESISTANCE

This test method is based on Cl. 5.4.4 and 6.4.4 of ETAG 034 part 1 (April 2012) and the EOTA Technical Report TR001 (February 2003).

### C.1 General

The principle is to establish the impact resistance of the kit considering hard body and soft body impacts. Besides, it is established the impact use categories to correspond to the degree of exposure to impacts in use.

The bodies to impact and the test equipment are indicated in EOTA TR 001. The points of impact shall be selected taking into account various modes of behaviour of cladding element include render coatings and supporting structure, varying according to whether the impact point is or is not located in an area of greater rigidity (at less than 50 mm from the edge of cladding element include render coatings).

Hard body impacts are:

- H1 and H2 (1 and 3 Joules respectively), carried out with the steel ball weighing 0,5 kg and from a height of 0,20 and 0,61 m respectively (at least in three locations).
- H3 (10 Joules), carried out with the steel ball weighing 1,0 kg and from a height of 1,02 m (at least in three locations).

Soft body impacts are:

- Small soft body S1 and S2 (10 and 60 Joules respectively), carried out with the soft ball weighing 3,0 kg and from a height of 0,34 and 2,04 m respectively (at least in three locations),
- Large soft body S3 and S4(300 and 400 Joules respectively), carried out with the spherical bag weighing 50,0 kg and from a height of 0,61 and 0,82 m respectively (at least in the space between two profiles).

*Note:* National building regulations in some member states may have specific requirements. The manufacturer may consider other energy values for the hard and soft body impacts. Any changes shall be indicated in the ETA.

At least, the mechanically weakest design shall be tested.

For finishing coats not tested on the rig or for complementary tests (double meshes, etc.), these tests can also be carried out on samples aged by immersion in water for 6 to 8 days and then dried for at least 7 days at  $(23 \pm 2) ^\circ\text{C}$  and  $(50 \pm 5) \% \text{RH}$ .

Within a type of finishing coat, the test shall be carried out with at least the thinnest layer (generally the lowest particle size grading with ribbed finishing aspect).

In case of possible optional use of key coat and/or decorative coat, at least the configurations without them shall be tested.

The size of the test specimen shall be chosen to carry out all the impacts indicated in Table C.1.

The dimensions of any indentation shall be reported. Noted shall be made of any damage caused.

### C.2 Test procedure

Test procedure can be carried out using one of following options:

- When the impact resistance is chosen by the manufacturer or it know, using the impact tests indicated in Table C.1 for this impact resistance chosen or know,
- When the impact category is not known, using the sequence for the impact tests, indicated in Table C.2, with the aim of obtaining the maximum resistance.

### C.3 Observations

- The diameter of the impact is measured and indicated,

- The presence of any micro cracks or cracks, at the impact point and at the circumference, is noted.

Table C.1 Hard and soft body impact tests

External impact and assessment						
		Category IV	Category III	Category II	Category I	
Hard body impact	H1	<ul style="list-style-type: none"> <li>• Weight: 0,5 kg</li> <li>• Impact: 1 joule (height 0,20 m)</li> <li>• No. impact: 3</li> <li>• Position of impacts: three different locations</li> </ul>	No penetrated <sup>(2)</sup> No perforated <sup>(3)</sup>	---	---	---
	H2	<ul style="list-style-type: none"> <li>• Weight: 0,5 kg</li> <li>• Impact: 3 joule (height 0,61 m)</li> <li>• No. impact: 3</li> <li>• Position of impacts: three different locations</li> </ul>	---	No penetrated <sup>(2)</sup> No perforated <sup>(3)</sup>	No deterioration <sup>(1)</sup>	No deterioration <sup>(1)</sup>
	H3	<ul style="list-style-type: none"> <li>• Weight: 1,0 kg</li> <li>• Impact: 10 joule (height 1,02 m)</li> <li>• No. impact: 3</li> <li>• Position of impacts: three different locations</li> </ul>	---	---	No penetrated <sup>(2)</sup> No perforated <sup>(3)</sup>	No deterioration <sup>(1)</sup>
Soft body impacts	S1	<ul style="list-style-type: none"> <li>• Weight: 3,0 kg</li> <li>• Impact: 10 joule (height 0,34 m)</li> <li>• No. impact: 3</li> <li>• Position of impacts: three different locations</li> </ul>	No deterioration <sup>(1)</sup>	No deterioration <sup>(1)</sup>	---	---
	S2	<ul style="list-style-type: none"> <li>• Weight: 3,0 kg</li> <li>• Impact: 60 joule (height 2,04 m)</li> <li>• No. impact: 3</li> <li>• Position of impacts: three different locations</li> </ul>	---	---	No deterioration <sup>(1)</sup>	No deterioration <sup>(1)</sup>
	S3	<ul style="list-style-type: none"> <li>• Weight: 50,0 kg</li> <li>• Impact: 300 joule (height 0,61 m)</li> <li>• No. impact: 1</li> <li>• Position of impacts: At least in the centre point of a kit</li> </ul>	---	---	No deterioration <sup>(1)</sup>	---
	S4	<ul style="list-style-type: none"> <li>• Weight: 50,0 kg</li> <li>• Impact: 400 joule (height 0,82 m)</li> <li>• No. impact: 1</li> <li>• Position of impacts: At least in the centre point of a kit</li> </ul>	---	---	---	No deterioration <sup>(1)</sup>
<sup>(1)</sup> Superficial damage, provided there is no cracking, is considered as showing "no deterioration" for all the impacts. <sup>(2)</sup> The test result is assessed as being "penetrate" if there is any cracking penetrating to be observed in the kit (to be also observed by the rear side) in at least 2 of 3 impacts. Superficial cracking (no penetrating) is allowed. <sup>(3)</sup> The test result is assessed as being "perforated" if there is a destruction of the kit that is shown up to a level beyond the reinforcement meshes or the cladding element is broken (to be observed by the rear side) in at least 2 of 3 impacts.						

#### C.4 Impact test sequence

When the impact category is not known, it is possible to obtain the maximum impact resistance following the increasing sequence for the impact tests, indicated in Table C.2.

To start the sequence indicated in Table C.2, it is considered that the kit might have a maximum impact resistance (impact use category I). If it is necessary, the manufacturer can choose to start the sequence from other impact resistance.

Table C.2 Impact sequence

Impact H2	In the case of no cracks appear, then carry out the hard body impact H3.
	In the case of superficial cracks appear but without penetrations or breaks (no penetrated and no perforated), then carry out the soft body impact S1. If the S1 impact result is satisfactory, the kit should be classified as Category III.
	In the case of penetrations or breaks appear, then carry out the hard body impact H1 and after that, the soft body impact S1. If the H1 and S1 impact results are satisfactory, the kit should be classified as Category IV.
Impact H3	In the case of no cracks appear, then carry out the soft body impact S2.
	In the case of superficial cracks appear but without penetrations or breaks (no penetrated and no perforated), then carry out the soft body impact S2.
Impact S2	In the case of penetrations or breaks appear, then carry out the soft body impact S1. If the S1 impact result is satisfactory, the kit should be classified as Category III.
	In the case of no cracks appear, and no cracks have appeared during the hard body impact H3, the TAB and the manufacturer may choose if carry out the soft body impact S4 directly (to obtain the Category I) or carry out the S3 impact (to secure the Category II) before the S4 impact.
Impact S3	In the case of cracks, penetrations or breaks appear; carry out the soft body impact S1. If the S1 impact result is satisfactory, the kit should be classified as Category III or IV (taking into account the hard body impact results).
	In case of no cracks appear, and hard body impacts H2 and H3 have been satisfactory, the kit should be classified as Category II.

	In the case of cracks, penetrations or breaks appear; carry out the soft body impact S1. If the S1 impact result is satisfactory, the kit should be classified as Category III or IV (taking into account the hard body impact results).
Impact S4	In case of no cracks appear and hard body impacts H2 and H3 have been satisfactory, the kit should be classified as Category I.
	In case of cracks, penetrations or breaks appear; carry out the soft body impact S3 has not been carried out previously, then carry out the soft body impact S3.
<i>Note:</i> In the case of the H1 or S1 impact results will not be satisfactory, the kit must not be classified.	

### C.5 Definition of the impact use categories

The categories in Table C.3 correspond to the degrees of exposure in use. They do not include an allowance for acts of vandalism.

Table C.3 Definition of Impact Categories

Impact Category	Description
I	A zone readily accessible at ground level to the public and vulnerable to hard body impacts but not subjected to abnormally rough use (e.g.: Façade bases in buildings sited in public locations, such as squares, schoolyards or parks. Cleaning gondolas can be used on the façade).
II	A zone liable to impacts from thrown or kicked objects, but in public locations where the height of the kit will limit the size of the impact; or at lower levels where access to the building is primarily to those with some incentive to exercise care (e.g.: Façade bases in buildings not sited in public locations (e.g. squares, schoolyards, parks) or upper façade levels in buildings sited in public locations, that occasionally can be hit by a thrown object (e.g. ball, stone, etc.). Cleaning gondolas can be used on the façade).
III	A zone not likely to be damaged by normal impacts caused by people or by thrown or kicked objects (e.g.: upper façade levels in buildings (not including base) not sited in public locations, that occasionally can be hit by a thrown object (e.g. ball, stone, etc.). Cleaning gondolas can not be used on the façade).
IV	A zone out of reach from ground level (e.g.: High façade levels that can not be hit by a throw object. Cleaning gondolas can not be used on the façade).

## ANNEX D HYGROTHERMAL BEHAVIOUR

This test method is based on Cl. 5.1.3.2.1 of ETAG 004 (2013) and Cl. 5.4.6 of ETAG 034 part 1 (April 2012).

### E.1 Principles related to the preparation of the rig

As a general rule, only one reinforced base coat and at the very most four finishing coats (vertical divisions) can be applied per rig.

If more than 4 finishing coats are proposed for the kit, the maximum number of coats, representative of the different types proposed, shall be tested on rig(s). Furthermore, if the water absorption of the reinforced base coat after 24 hours is equal to or more than  $0,5 \text{ kg/m}^2$  (see Cl. 2.2.4), each type of finishing coats containing a pure polymeric binder (no cementations) shall be submitted to hygrothermal cycles on rig(s).

If different finishing coats can be used in the kit, the lower part of the test piece (1,5 x height to define by the Technical Assessment Body according to the dimensions of the rig) consists of the reinforced base coat only without any finishing coat.

The kit and rendering systems have to be built and applied, in accordance with the manufacturer's instructions, to a sufficiently stabilised supporting structure.

The dimensions of the rig shall be:

- Surface  $> 6,0 \text{ m}^2$ .
- Width  $> 2,5 \text{ m}^2$ .
- Height  $> 2,0 \text{ m}^2$ .

An opening includes at the corner of the rig,  $0,40 \text{ m}$  wide by  $0,60 \text{ m}$  high, positioned  $0,40 \text{ m}$  from the edges (see Figure D.1).

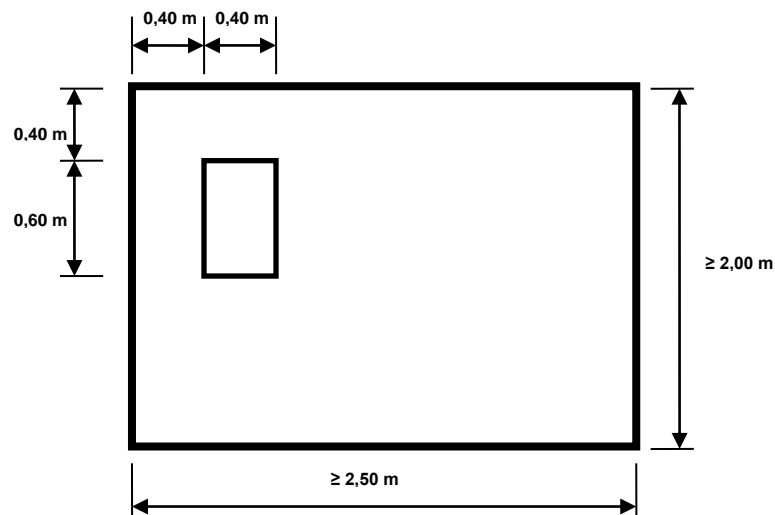

Figure D.1 – Example of hygrothermal behaviour test specimen

*Note:* If four rendering systems are foreseen to be applied to the rig, two symmetrical openings shall be applied in order to affect all tested finishing coats.

Special methods for reinforcing corners of the opening are applied, if necessary.

Installation of the window sill is responsibility of the manufacturer.

### D.2 Preparation of the rig

The rig preparation shall be made by the manufacturer. It shall be supervised by the laboratory in charge of the test regarding:

- Checking of the respect of manufacturer prescriptions: all stages shall be in accordance with the Technical File of the manufacturer,
- Registering of all the stages of the installation:
  - The date and time of the various stages,
  - Temperature and % relative humidity during the installation (every day – at least at the beginning),
  - Name and production lot of the components,
  - Figure describing the rig (place of the fixings, profiles, brackets and of the joints between the cladding element, ...),
  - Way of renders preparation (tool, % of mixing, possible pause time before application,...) as well as their way of application (hand tool, machines, number of layers,...),
  - Quantities and/or thickness of renders applied per square meter,
  - Drying period between each layer,
  - Use and position of accessories,
  - Any other information.

### **D.3 Conditioning of the rig**

The rendering system is cured inside for a minimum of 4 weeks. During the curing time the ambient temperature shall be between 10 °C and 25 °C. The relative humidity shall not be less than 50 %. To ensure that these conditions are met, records shall be made at regular intervals.

To prevent the rendering system from drying out too rapidly, the ETA applicant may require the rendering system to be wetted once per week by spraying for approximately 5 minutes. This wetting shall start at a time according to the prescriptions of the manufacturer.

During the curing time, any deformations of the kit, i.e. blistering, cracking, are recorded.

### **D.4 Hygrothermal cycles**

The test apparatus is positioned against the front face of the rig, 0,10 to 0,30 m from the edges.

The specified temperatures during the cycles are measured at the surface of the rig. The regulation shall be obtained by adjustment of the air temperature.

#### **D.4.1 Heat - rain cycles**

The rig is subjected to a series of 80 cycles, comprising the following phases:

1. Heating to 70°C (rise for 1 hour) and maintaining at  $(70 \pm 5)$  °C and 10 % to 30 % RH for 2 hours (total of 3 hours),
2. Spraying for 1 hour (water temperature  $(+ 15 \pm 5)$  °C, amount of water 1 l/m<sup>2</sup> min),
3. Leave for 2 hours (drainage).

#### **D.4.2 Heat - cold cycles**

After at least 48 hours of subsequent conditioning at temperatures between 10 °C and 25 °C and a minimum relative humidity of 50 %, the same test rig is exposed to 5 heat/cold cycles of 24 hours comprising the following phases:

1. Exposure to  $(50 \pm 5)$  °C (rise for 1 hour) and maximum 30 % RH for 7 hours (total of 8 hours),
2. Exposure to  $(-20 \pm 5)$  °C (fall for 2 hours) for 14 hours (total of 16 hours).

### **D.5 Observations during the tests**

At periods of every four cycles during the heat/rain cycles and at every cycle during the heat/cold cycles, observations relating to a change in characteristics or performance (blistering, detachment, crazing, loss of adhesion, formation of cracks, etc.) of the entire kit and of the part of the rig consisting of only the reinforced base coat are recorded as follows:

- The surface finish of the kit is examined to establish whether any cracking has occurred. The dimensions and position of any cracks shall be measured and recorded.
- The surface shall also be checked for any blistering or peeling and the location and extent shall again be recorded.
- The sills and profiles shall be checked for any damage/degradation together with any associated cracking of the finish. Again, the location and extent shall be recorded.

Following the completion of the test, a further investigation is conducted involving removal of sections containing cracks to observe any water penetration within the kit.

### **D.6 After the test**

The following additional tests shall be carried out on samples taken of the test specimens:

- Impact resistance (see Cl. 2.2.7),
- Bond strength (see Cl. 2.2.8),
- Optionally mechanical resistance of fixing device of cladding element on subframe (see Cl. 2.2.9.1 and Cl. 2.2.9.2).

This test shall be performed after at least 7 days drying.

### **D.7 Test report**

The test report shall detail the following:

- Observations recorded during the test (see Cl. D.5),
- Photographs to detail the damages occurred on each specimen after the cycles and, if necessary, after each visual inspection.



## ANNEX E FREEZE-THAW BEHAVIOUR

This test method is based on Cl. 5.1.3.2.2 of ETAG 004 (2013).

The freeze-thaw test shall be carried out as determined by the analysis of the capillarity test (see Cl. 2.2.4), i.e. shall be conducted except if the water absorption after 24 hours of both the reinforced basecoat and the rendering system determined with each type of finishing coat is less than 0,5 kg/m<sup>2</sup>.

### E.1 Preparation of the sample

These samples are prepared according to the manufacturer's instructions and then stored for at least 28 days at (23 ± 2) °C and (50 ± 5) % RH.

The test shall be prepared with a substrate according to the cladding element type intended to be used for the kit.

The initial test specimens (without accelerated ageing procedures) shall be prepared at the same time that this test specimen.

At least 3 test specimens of dimensions 500 x 500 mm shall be tested for each case.

Each test specimen has to be made of:

- 2 cladding elements of the same dimensions put according to Figure E.1, with the exterior joint treatment (joint filler and/or joint tape),
- Covered by:
  - Case 1: reinforced basecoat without finishing coat if its water absorption is equal to or higher than 0,5 kg/m<sup>2</sup> after 24 hours,
  - Case 2: all the configurations of rendering systems proposed by the manufacturer (i.e. reinforced basecoat covered with each type of finishing coat (associating or not) key coat and/or decorative coat which lead to a water absorption equal to or higher than 0,5 kg/m<sup>2</sup> after 24 hours. If the application of the key coat and/or the decorative coat is optional, at least configurations without them shall be tested).

The sides of test specimens shall be protected by watertightness coating up to back side

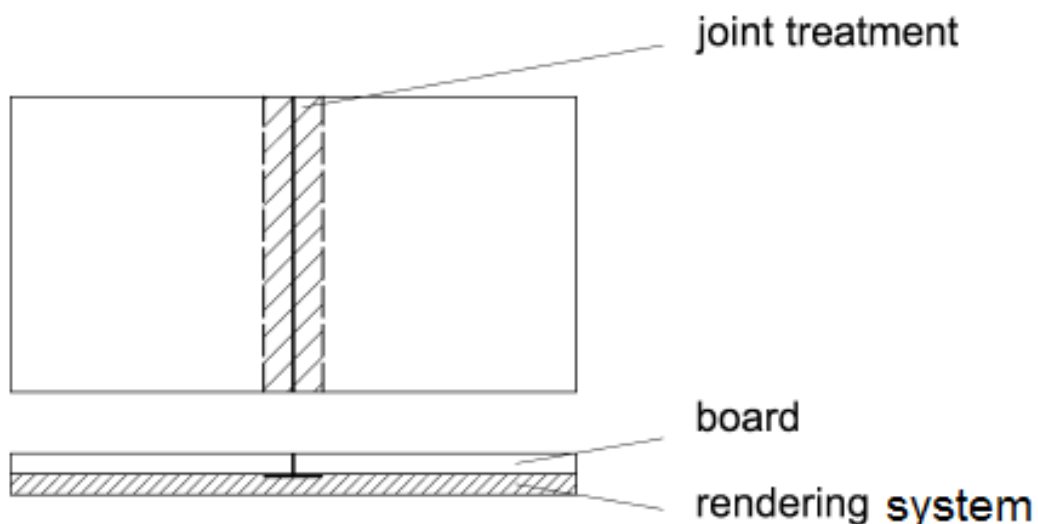

Figure E.1 – Example of freeze-thaw behaviour test specimen

### E.2 Freeze-thaw cycles

The test specimens are then subjected to a series of 30 cycles (one cycle lasts for 24 hours) comprising:

- Exposure to water for 8 hours at initial temperature of  $(23 \pm 2)$  °C by immersion of the samples, with rendering system submerged in a water bath according to the method described in Cl. 2.2.4,
- Freezing to  $(-20 \pm 2)$  °C (fall for 5 hours at the sample surface and for 2 hours in the conditioned air) for respectively 11 and 14 hours (total of 16 hours).

If the test is interrupted, because the samples are handled manually and there are stops during weekends or holidays, the samples shall always be stored at a temperature of  $(-20 \pm 2)$  °C between cycles.

*Note:* The specified temperatures are measured at the surface of the samples. The regulation is obtained by conditioned air.

### **E.3 Observations**

At the end of the test, observations relating to a change in characteristics of the surface or to the behaviour of the entire kit are recorded according to Cl. D.5 of Annex D.

Any distortion at the edges of the samples shall also be reported.

### **E.4 After the test**

A bond strength test shall be performed in accordance with Cl. 2.2.8 on each sample submitted to freeze-thaw cycles.

### **E.5 Test report**

The test report shall detail the following:

- Observations recorded during the test (see Cl. D.5 of Annex D),
- Photographs to detail the damages occurred on each specimen after the cycles and, if necessary, after each visual inspection.

## **ANNEX F WATER ABSORPTION – CAPILLARITY**

This test method is based on Cl. 5.1.3.1 of ETAG 004 (2013).

These test have 3 purposes, to determine:

- The water absorption, in order to assess, in Cl. F.3, whether it is acceptable,
- Which finishing coats should be applied on the rig to be subjected to hygrothermal testing (Cl. 2.2.13),
- Whether the freeze-thaw testing describe in Cl. 2.2.14 is necessary.

### **F.1 Preparation of the sample**

Samples are prepared, each by taking a piece of the specified cladding element, surface area to be at least 200 mm x 200 mm, and applying, in accordance with the manufacturer's instructions, e.g. thickness, mass per unit area and method of application, both:

- the reinforced basecoat alone and
- all the configurations of complete rendering systems proposed by the manufacturer, i.e. reinforced basecoat covered with each type of finishing coat and (associating or not) key coat and/or decorative coat. If the application of the key coat and/or the decorative coat is optional, at least configurations without them shall be tested.

Exception for not testing all the mentioned configurations above can be accepted provided, that a technical argumentation is given in the Evaluation Report.

Within a type of finishing coat, the test shall be carried out with at least the thickest layer (generally higher particle size grading with floated finishing aspect).

Three samples are prepared for each configuration.

The prepared samples are conditioned for at least 7 days at  $(23 \pm 2)$  °C and  $(50 \pm 5)$  % RH.

The edges of the samples, including the cladding element, are sealed against water, to ensure that during subsequent testing, only the face of the reinforced basecoat or the rendering system is subject to water absorption.

They are then subject to a series of 3 cycles comprising the following phases:

- 24 h immersion in a water bath (tap water) at  $(23 \pm 2)$  °C. The samples are immersed rendered face downwards, to a depth of 2 to 10 mm, the depth of immersion dependent upon surface roughness. To achieve complete wetting of rough surfaces, the samples shall be tilted as they are introduced into the water. The depth of immersion can be regulated in the water tank by means of a height-adjustable slat,
- 24 h drying at  $(50 \pm 5)$  °C.

If interruptions are necessary, e.g. at weekends or holidays, the samples are stored at  $(23 \pm 2)$  °C and  $(50 \pm 5)$  % RH after the drying at  $(50 \pm 5)$  °C.

After the cycles, the samples are stored for at least 24 h at  $(23 \pm 2)$  °C and  $(50 \pm 5)$  % RH.

### **F.2 Capillarity test procedure**

To start the capillarity test the samples are again immersed in a water bath as described above.

The samples are weighed after 3 minutes immersion in the bath (reference mass) and then after 1 hour and 24 hours. Prior to the second and subsequent weighing, water adhering to the surface of the sample is removed with a damp sponge cloth.

### F.3 Analysis of results

Calculation is undertaken to determine the mean water absorption of the three samples per square meter after 1 and 24 hours. The outcome of these results will determine the following:

- Acceptability of the kit : If the water absorption of the reinforced basecoat after 1 hour is equal to or more than 1 kg/m<sup>2</sup>, the water absorption after 1 hour of each rendering system shall be less than 1 kg/m<sup>2</sup>,
- Hygrothermal behaviour : For the choice of the finishing coats to be applied on the rig, see Cl. 2.2.13,
- Freeze/thaw test: Freeze/thaw test (Cl. 2.2.14) is necessary if the water absorption of either the reinforced basecoat or of the rendering coating is equal to or more than 0,5 kg/m<sup>2</sup> after 24 hours.

*Note:* Special requirements for some kits:

- In order to provide information about the stabilization, the water absorption measured can be plotted on a chart as a function of  $\sqrt{t}$  ,
- If the kit is applied down to the ground and is therefore exposed to rising damp, the additional tests may be carried out.

## ANNEX G MECHANICAL RESISTANCE OF FIXING DEVICE OF CLADDING ELEMENT ON SUBFRAME

This test method is based on Cl. 5.4.2.1 of ETAG 034 part 1, Family A (April 2012).

### G.1 General

This Annex specifies procedures for following tests of resistance of the fixing devices applied with cladding element:

- Test of the resistance to pull-through under tension load,
- Test of the tear resistance under shear load.

The fixing device shall be installed in accordance with the manufacturer's installation instructions. The test is performed in ambient conditions and if needed with consideration of aspects of durability (test after hygrothermal cycles, see Cl. 2.2.13 and test after freeze-thaw cycles, see Cl. 2.2.14) until failure occurs. Each test shall be carried out at least on 5 test specimens.

The result of each test is to be expressed in  $N$  with accuracy in integer.

The test report shall contain for each tested combination at least characteristics mentioned below:

- Description of used fixing device including type of fixing device, nominal characteristic diameter, nominal length, type and nominal thickness of coating,
- The each tested value of resistance, description of failure mode, average and sample standard deviation,
- The characteristic value of resistance given as 95 % quartile on confidence level 75 % for  $V_x$  as unknown according to EN 1990, Annex D, Cl. 7.2.

### G.2 Resistance to pull-through under tension load $F_{tI}$

The samples (dimensions of samples shall be given in function of supporting ring diameter) with fixing devices driven through the center, middle of the edge and the corner are applied as show in Figures G.1, G.2 and G.3. The diameter of the supporting ring shall be between 50 mm and 350 mm. The fixing device is placed in the center, in the middle of the edge and the corner. It depends on manufacturer's installation instructions. The most critical case shall be explained.

An axial tension load is exerted on the fixing device. The speed rate shall be adjusted to 5 mm/min. The force can be applied either by pushing on the head of the fixing device or pulling the end of the fixing device.

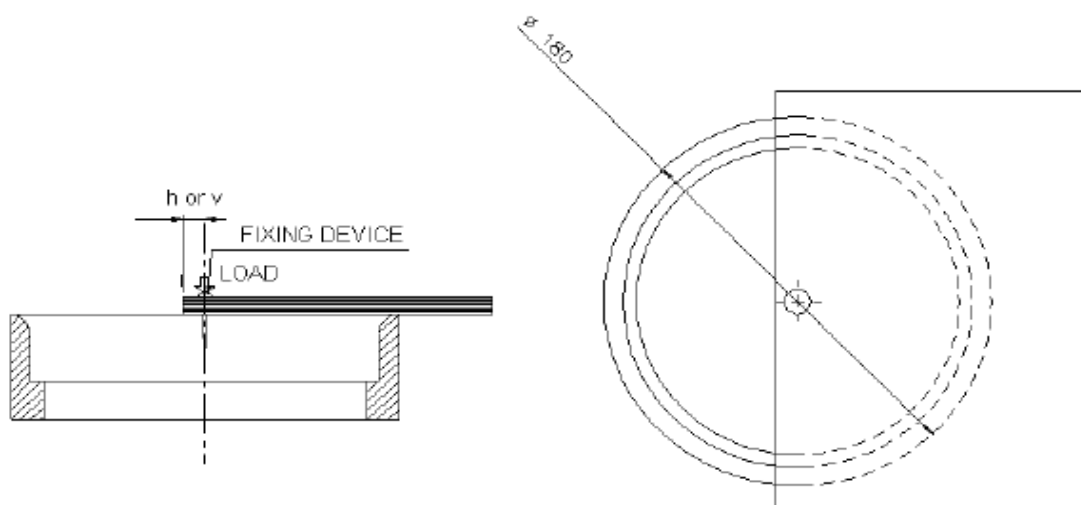

Figure G.1 The fixing device is placed in the middle of the edge

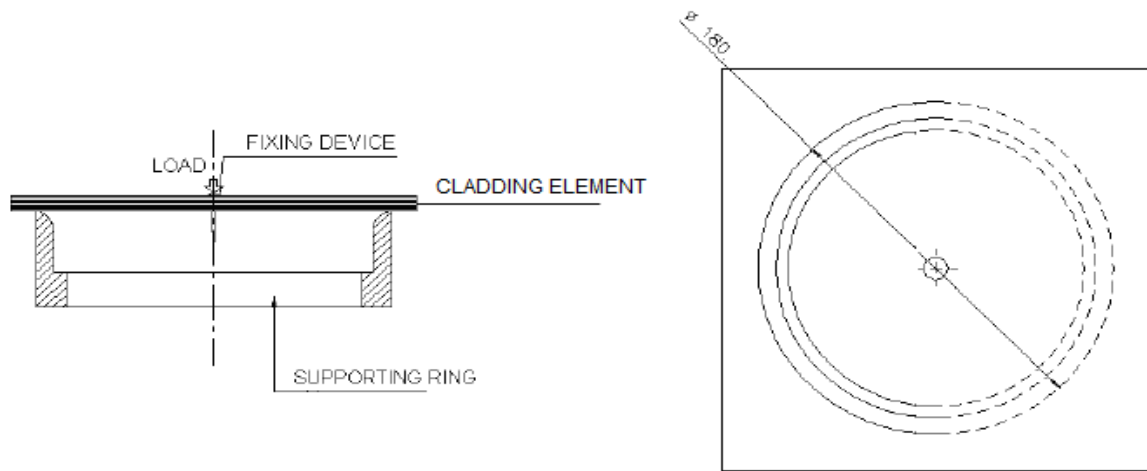

Figure G.2 The fixing device is placed in the centre

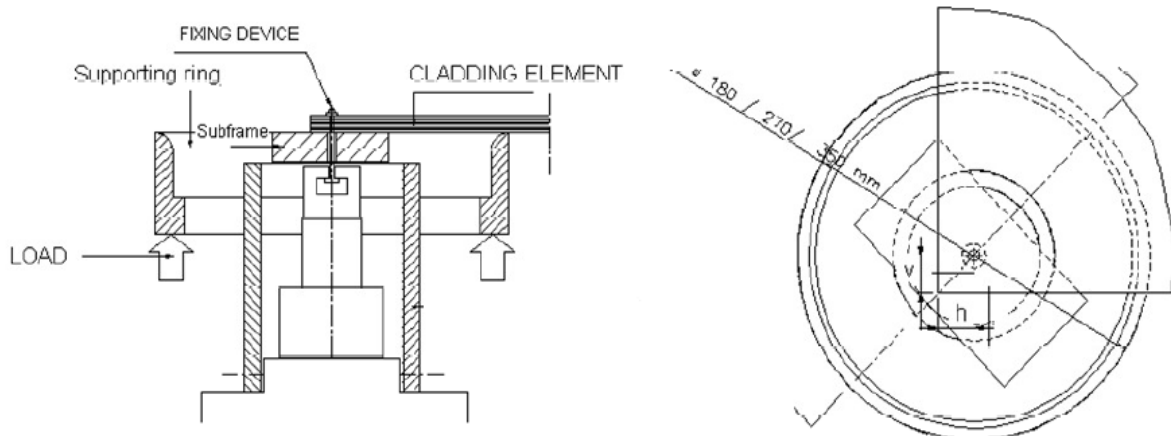

Figure G.3 The fixing device is placed in the corner

### G.3 Resistance to pull-through under shear load $F_{sl}$

The samples (dimensions (250x250) mm at least) are mechanically fixed to the substrate (e.g. wooden batten or metal profile) with one fixing device. The fixing device is applied in the middle of the edge and the corner of the cladding element as it is shown in the Figure G.4. The most critical case shall be explained.

The speed rate shall be adjusted to 5 mm/min. Test to destruction shall be performed. During the test diagram loading / deformation shall be recorded and maximal loading on destruction shall be registered.



Figure G.4 Resistance to pull-through under shear loads

## ANNEX H PULL-THROUGH / PULL-OUT RESISTANCE TEST

This test method is based on Cl. 5.4.2.3.4 of ETAG 034 part 1 (April 2012).

The principle is to establish the resistance of the connection between profiles of the subframe and cladding fixings.

The test shall comprise one or more of the following tests:

- simple pull-through test  $R_{s(\rho t)}$ , to determine the resistance of the fixing through the perforation in the subframe profile,
- simple pull-out test  $R_{s(\rho o)}$ , to determine the resistance of the fixing through the perforation in the subframe profile,
- combination of the pull-through and pull-out test  $R_{s(c)}$ , to determine the resistance of the connection between the subframe profile and the cladding fixing.

The manufacturer shall decide which of these tests shall be carried out taking into account the kit configurations.

### H.1 Preparation of the test specimen

For each pull-through, pull-out or the combination of both, a minimum of 3 test specimens shall be tested.

The test specimens have to be mounted in accordance with the manufacturer instructions.

Each test specimen will be composed of:

- test a) and b): one subframe profile and the fixing defined for its connection with the cladding fixing,
- test c): the subframe profile, the cladding fixing and the fixing defined for the connection between them.

The length of the subframe profile should be 300 mm approximately, however, depending on the kit configuration, other dimensions may be chosen.

The test specimens are conditioned for at least 2 hours at  $(23 \pm 2)$  °C before the test.

### H.2 Test equipment

The apparatus have to consist of:

- A dynamometer,
- A test support as show in the following figures, depending on the type of test indicated above.

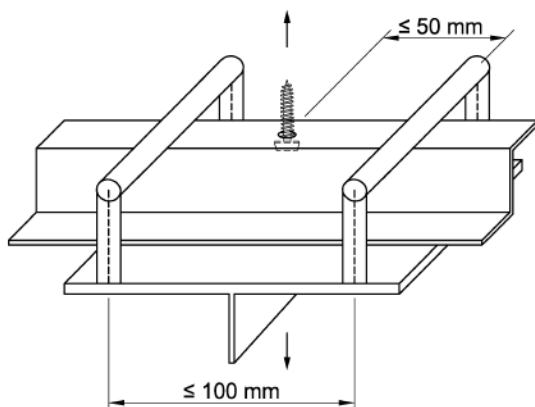

Figure H.1 – Example of pull-through test

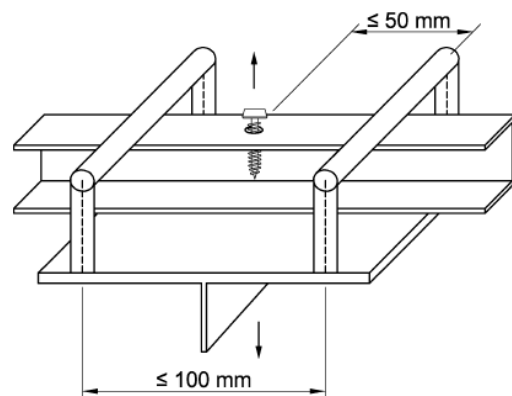

Figure H.2 – Example of pull-out test

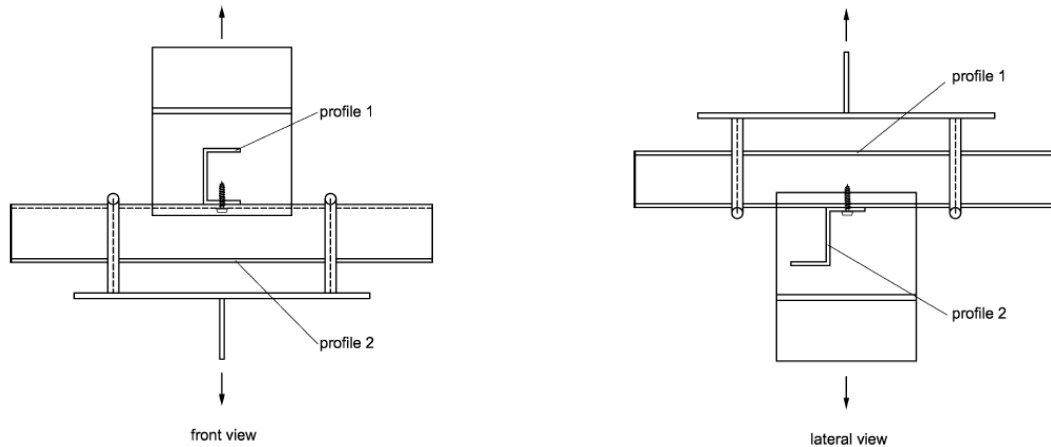

Figure H.3 – Example of pull-through and pull-out combination test

### H.3 Test procedure

The test shall be carried out using a tensioning speed of 20 mm/min. When relevant, lower speed may be considered.

In tests a) and b), the fixing device have to be placed perpendicular to the subframe profile as described in Figure H.1 and Figure H.2, and the force have to be applied either through the support or by the fixing device until failure.

In test c), the force have to be applied through the supports until failure.

The failure have to be defined by any one the following events:

- Any profile breaks,
- Any fixing device breaks.

### H.4 Test results and test report

The result of each test is to be expressed in  $N$  with accuracy in integer.

The test report shall contain for each tested combination at least characteristics mentioned bellow:

- Description of used fixing device including type of fixing device, nominal characteristic diameter, nominal length, type and nominal thickness of coating,
- The each tested value of resistance, description of failure mode, average and sample standard deviation,
- The characteristic value of resistance given as 95 % quartile on confidence level 75 % for  $V_x$  as unknown according to EN 1990, Annex D, Cl. 7.2.



## **ANNEX I                    BRACKET RESISTANCE (HORIZONTAL AND VERTICAL LOAD)**

This test method is based on Annex E of ETAG 034 part 2 (April 2012).

### **I.1    General**

The aim of the test is to determine the load bearing capacity and wind resistance of the brackets and their fixing devices to the subframe under shear and tension loads respectively.

The test shall be performed if calculation according to relevant standards is not possible.

Resistance of brackets shall be tested under:

- Vertical load (weight), see Cl. I.4.1,
- Horizontal load (wind), see Cl. I.4.2.

The test and measuring equipment shall be in accordance with Cl. I.2.

The test specimens shall be tested in accordance with Cl. I.3.

### **I.2    Test equipment**

The equipment is made of a traction machine of class 1 in accordance with EN ISO 7500-1, minimum capacity of 1000 daN, in the vertical axis, whose main elements are the following:

- A lower part allowing fixing of the brackets to the profile,
- An upper mobile part allowing fixing to the profile.

These parts have to be placed in the same axis

Additionally, a load-displacement measurement device shall be used.

The lower part of the support is made of rigid substrate (e.g. a horizontal basis and vertical perpendicular surface, see Figure I.2).

This substrate shall:

- be rigidly fixed on the lower tray of the machine,
- be rigid enough to allow the correct execution of the test.

Whenever the substrate is not made of steel, steel plates shall be used provide a support surface under the brackets (minimum thickness 5 mm and with a surface area at least equal to the surface of the bracket wing, incorporating a hole of diameter equal to that of fixing).

The upper part consists of a traction device appropriate to the section of the profile.

The upper mobile part and the attached profile shall be vertically aligned with the substrate.

The displacements under load can be taken equal to displacements of the mobile crosspiece but it is preferable to have sensors of displacement:

- either in the axis of the profile,
- or on the head of each bracket.

The displacement sensors are linked up with a graphic recorder allowing to draw the curve strength-displacement (see Figure I.1).

### **I.3    Mounting provisions of test specimens**

#### **I.3.1    Fixings of brackets to the substrate**

The brackets shall be fixed to the substrate according to the following:

- Vertical load test shall be in accordance with Figure I.2,

- Horizontal load test shall be in accordance with Figure I.3,
- The critical position of the fixing (the weakest design) considering the use shall be tested,
- The type of anchor between the bracket and the substrate has to be chosen according to the type of substrate and the manufacturer specifications. Whenever no fixings to substrate are defined by the manufacturer, bolts of suitable diameter adapted to predrilling (diameter 6 mm minimum) by using washers shall be used,
- The fixing bolt (anchor) on the support shall be positioned in the oblong hole at the maximum specified distance from the profile.

*Note:* The anchors (fixing between the bracket and the substrate) shall not represent a weak point of the test specimen.

### **I.3.2 Brackets**

Each test specimen shall consist of one (asymmetrical) or two brackets mounted in accordance with the specifications of the manufacturer.

Nevertheless, an asymmetrical bracket may be tested by means of two brackets in opposition on both sides of the profile. The test may be done on a single bracket as well (asymmetric layout).

Whenever several lengths of wings are available, at least the weakest mechanically bracket configuration shall be tested.

### **I.3.3 Fixings profile-bracket**

Profile shall be fixed to brackets according to the following:

- The type of bracket fixing on the profile has to correspond to the fixing to be used in the kit,
- Fixings shall be installed in accordance with the specifications of the manufacturer,
- The critical position of the fixings (the weakest design) considering the use shall be tested.

### **I.3.4 Profile**

Whenever it is possible, the profile defined for the kit shall be used in the tests.

The metallic profile can also be simulated by a square or rectangular section steel tube 1,5 mm minimum thickness.

## **I.4 General test procedure (vertical and horizontal loads)**

A minimum of 5 test specimens shall be tested.

The brackets are subjected to a succession of cycles during the test. In each cycle a growing load is applied and then returned to zero.

The Figure I.1 shows an example of test procedure.

Load shall be applied in constant speed to the profile in order to avoid a dynamic failure of the test specimen.

*Note:* The term “displacement” refers to the measured distance at the head of wing during the application of the load. The term “residual distortion” refers to the measured distance at the head of wing after the application of the load.

According to the typology of bracket, the manufacturer shall decide if cycles are defined either by means of load growths or by means of displacement growths under load.

*Note:* The manufacturer shall appraise the necessity for previous tests in order to define the most appropriate growth (load or displacement) for each bracket.

If the cycle succession is defined according to load growths, it shall be carried out in steps of 10 daN in vertical load resistance tests and in steps of 20 daN in horizontal load resistance tests. The load shall be applied in order to meet the condition: constant speed of load < 500 daN/min.

If the cycle succession is defined according to displacement growths, it shall be carried out in steps of 0,25 mm, 0,5 mm or 1,0 mm depending on the behavior of the bracket under load. The load shall be applied in order to meet the condition: constant speed of load  $\leq 5$  mm/min.

The mean and characteristic resistance shall be obtained for each test result series from the test specimens ("I" specimens) e.g.  $F_{r1}$  to  $F_{ri}$ ,  $F_{1d1}$  to  $F_{1di}$ ,  $F_{3d1}$  to  $F_{3di}$  and  $F_{s1}$  to  $F_{si}$ .

The characteristic resistance ( $R_{cr}$ ,  $R_{cd1}$ ,  $R_{cd3}$  and  $R_s$ ) of the bracket is obtained according to EN 1990, Annex D, Cl. 7.2.

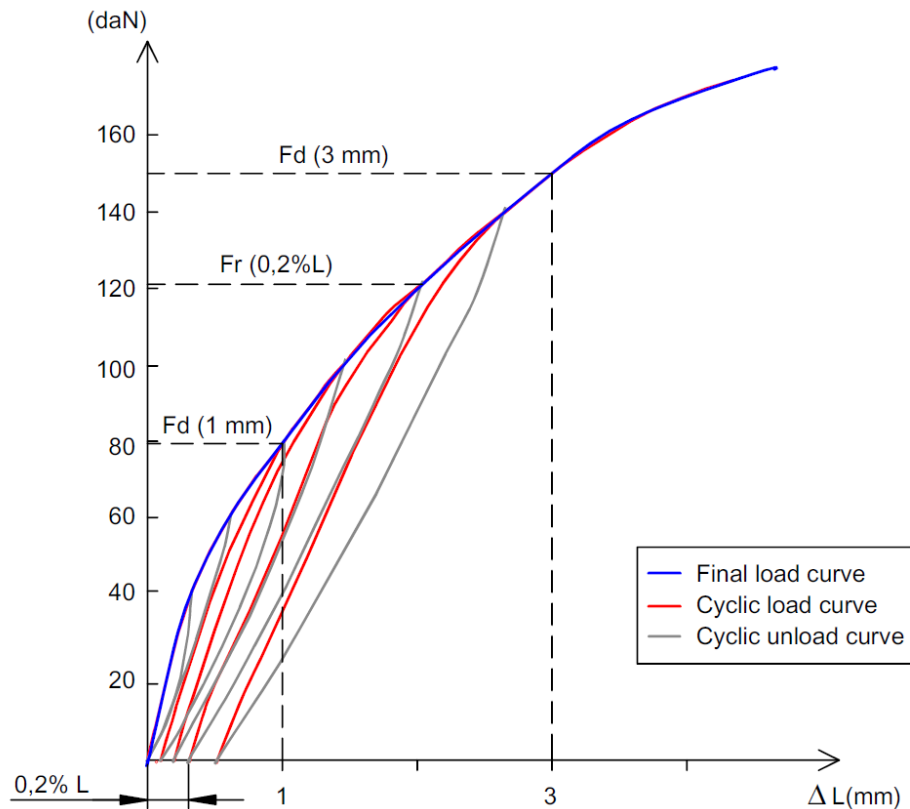

Figure I.1 – Example of curve strength-displacement

#### I.4.1 Vertical load resistance test

Vertical load test shall be carried out considering the following:

- The test specimen shall be in accordance with Figure I.2,
- The test shall be carried out in accordance with Cl.I.3,
- The results shall be in accordance with Cl. I.4.

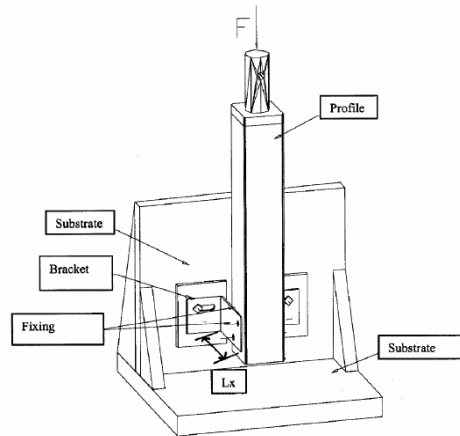

Figure I.2 – Vertical load test. Example of test device

Following results shall be recorded during the tests:

**1<sup>st</sup> criterion:  $F_r$  load**

$F_r$  is the load that causes a residual distortion on the bracket measured at the head of wing (after returning to zero) equal to:

$$\Delta L = \frac{0,2 \cdot L_x}{100} \text{ where } L_x \text{ is the length of the perpendicular wing to the substrate.}$$

*Note:* To obtain  $F_r$  with accuracy, growths between cycles (load or displacement) shall be appropriate in order to avoid big gaps between the residual distortions obtained after consecutive cycles.

**2<sup>nd</sup> criterion:  $F_{1d}$  and  $F_{3d}$  loads**

$F_{1d}$  and  $F_{3d}$  are the loads that causes a displacement of 1 mm a 3 mm respectively under load measured at the head of wing.

*Note:* Due to the fact that  $F_{1d}$  and  $F_{3d}$  are related to displacement values instead of residual distortion values, it is possible that loads  $F_{1d}$  and/or  $F_{3d}$  can be attained before  $F_r$  load is reached.

**3<sup>rd</sup> criterion:  $F_s$  load**

$F_s$  is the load that corresponds to the failure.

The failure is defined by any one of the following events:

- Any bracket breaks,
- Any bracket presents a significant permanent deflection,
- Any fixing breaks.

*Note:* When a failure is defined by significant permanent deflection, a unified failure criterion (e.g. 10 mm displacement) shall be followed for all test specimens belonging to the same test group.

**I.4.2 Horizontal load resistance test**

Horizontal load test shall be carried out considering the following:

- The test specimen shall be in accordance with Figure I.3. Brackets are fixed to the horizontal substrate,
- The test shall be carried out in accordance with Cl. I.3,
- The results shall be in accordance with Cl. I.4.

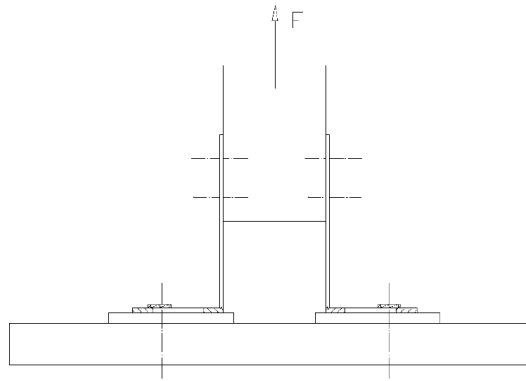

Figure I.3 – Horizontal load test. Example of test device.

Following results shall be recorded during the tests:

**1<sup>st</sup> criterion:  $F_m$  load**

$F_m$  is the load that causes a residual distortion on the bracket measured at the head of wing (after returning to zero) equal to 1 mm.

*Note:* To obtain  $F_m$  with accuracy, growths between cycles (load or displacement) shall be appropriate in order to avoid big gaps between the residual distortions obtained after consecutive cycles.

**2<sup>nd</sup> criterion:  $F_i$  load**

$F_i$  is the load that corresponds to the failure.

The failure is defined by any one of the following events:

- Any bracket breaks,
- Any bracket presents a significant permanent deflection,
- Any fixing breaks.

*Note:* When a failure is defined by significant permanent deflection, a unified failure criterion (e.g. 10 mm displacement) shall be followed for all test specimens belonging to the same test group.

**I.5 Test report**

Test report shall include:

- Material and geometric characteristic of the brackets, including drawings of the brackets,
- Description of the failure of the test specimens (break, significant permanent deflection, failure of system fixing), including the failure criterion in case of failure due to significant permanent deflection,
- Figure including position and number of fixing between components for each test group,
- The number of brackets corresponding to the test results, including a reference to the use of symmetrical or asymmetrical brackets. Whenever a test has been carried out by means of two symmetrical brackets, test results shall clearly refer to the corresponding configuration,
- The curve strength-displacement for each test specimen,
- Identification of fixings (between the brackets and the substrate or between the brackets and the profile):
  - Description or generic type,
  - Dimensions (diameter, length, etc.),.

- Material,
- Fixing method to the substrate,
- Washers and nuts (if they are used):
  - Description or generic type,
  - Dimensions (diameter, length, etc.),
  - Material.

## ANNEX J ASSESSMENT METHODS APPLIED IN EU / EFTA MEMBER STATES FOR ASSESSING THE FIRE PERFORMANCE OF FACADES

Country	Assessment method
Austria	ÖNORM B 3800-5
Czech Republic	ČSN ISO 13785-1
Denmark, Sweden, Norway	SP Fire 105
Finland	<ul style="list-style-type: none"> <li>• Tekniikka opastaa 16 (Engineering guidance 16),</li> <li>• "Kerrostalojen lisälämmöneristeen paloturvallisuus korjausrakentamisessa" (Fire safety of extra thermal insulation in reconstruction), 2001, published by SPEK.</li> </ul>
France	LEPIR 2
Germany	<ul style="list-style-type: none"> <li>• DIN 4102-20 Complementary reaction-to-fire test for claddings of exterior walls,</li> <li>• Technical regulation A 2.2.1.5</li> </ul>
Hungary	MSZ 14800-6:2009 Fire resistance tests. Part 6: Fire propagation test for building façades
Ireland	BS 8414 (BR 135)
Poland	PN-B-02867:2013
Slovak Republic	ISO 13785-2
Switzerland, Liechtenstein	<ul style="list-style-type: none"> <li>• DIN 4102-20</li> <li>• ÖNORM B 3800-5</li> <li>• Prüfbestimmung für Aussenwandbekleidungssysteme</li> </ul>
UK	BS 8414 -1:2015 and BS 8414-2:2015