



EUROPEAN ASSESSMENT DOCUMENT

EAD 130089-00-0304

February 2018

STRUCTURAL WET AND/OR COLD GLUED FINGER JOINTED SOLID TIMBER

The reference title and language for this EAD is English. The applicable rules of copyright refer to the document elaborated in and published by EOTA.

This European Assessment Document (EAD) has been developed taking into account up-to-date technical and scientific knowledge at the time of issue and is published in accordance with the relevant provisions of Regulation (EU) No 305/2011 as a basis for the preparation and issuing of European Technical Assessments (ETA).

Contents

1	Scope of the EAD	4
1.1	Description of the construction product	4
1.2	Information on the intended use(s) of the construction product	5
1.2.1	Intended use(s).....	5
1.2.2	Working life/Durability.....	5
2	Essential characteristics and relevant assessment methods and criteria	6
2.1	Essential characteristics of the product	6
2.2	Methods and criteria for assessing the performance of the product in relation to essential characteristics of the product	6
2.2.1	Strength and stiffness properties of timber	6
2.2.2	Bending strength of finger joints as bending strength of timber.....	6
2.2.3	Durability of bonding strength.....	8
2.2.4	Durability against biological attack	11
2.2.5	Reaction to fire	11
2.2.6	Content, emission and/or release of dangerous substances	11
3	Assessment and verification of constancy of performance	13
3.1	System(s) of assessment and verification of constancy of performance to be applied	13
3.2	Tasks of the manufacturer	13
3.3	Tasks of the notified body	14
3.4	Special methods of control and testing used for the assessment and verification of constancy of performance	15
3.4.1	Measurement of moisture content of the structural solid timber	15
3.4.2	Bending tests of finger joints	15
4	Reference documents	16

1 SCOPE OF THE EAD

1.1 Description of the construction product

The EAD covers structural finger jointed timber made from one of the following softwood species: Norway spruce (*Picea abies*, PCAB), Fir (*Abies alba*, ABAL) and Scots pine redwood (*Pinus sylvestris*, PNSY) graded according to EN 14081-1.

The structural finger jointed timber consists of only one species throughout. Norway spruce and Fir are considered as one species.

One component polyurethane formaldehyde-free adhesives type I according to EN 15497:2014, clause 5.2.3.3 are used to glue the finger joints.

The depth h of the structural finger jointed timber is not less than 30 mm and not more than 40 mm. The width b of the structural finger jointed timber is not less than 50 mm and doesn't exceed 60 mm. The dimensions refer to a moisture content of 20 %. Deviations according to dimensional tolerance class 1 of EN 336 are permitted.

The finger joints are visible on the broadside of timber (see Figure 1). The maximum glue line thickness of the finger joints is 0,1 mm.

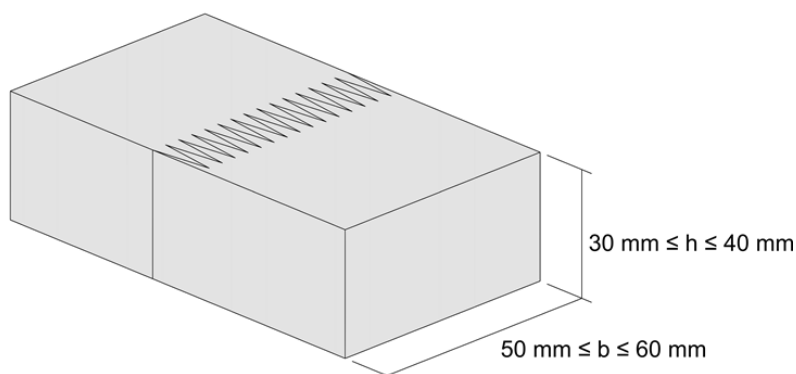

Figure 1 View on the structural finger jointed timber

Structural finger jointed timber treated with fire retardants and the use of recycled materials are not covered by this EAD.

The product is not fully covered by the following harmonised technical specification: EN 15497:2014

The structural finger jointed timber fulfills the minimum production provisions according to EN 15497:2014, Annex G, unless otherwise specified in the following.

Deviating from EN 15497 timber members with different moisture contents are used to glue the finger joints. The difference of the moisture content of the timber members may be up to 20 percentage points. The moisture content of the timber members can exceed 18 % but is not higher than 40 %. The minimum moisture content of the timber members is 8 %.

Additionally, the timber and air temperature in the production facility and during the curing process can be lower than 15 °C but is not lower than 10 °C. The provisions in the EAD are valid for a maximum timber and air temperature of 30 °C in the production facility and during the curing process.

Concerning product packaging, transport, storage, maintenance, replacement and repair it is the responsibility of the manufacturer to undertake the appropriate measures and to advise his clients on the transport, storage, maintenance, replacement and repair of the product as he considers necessary.

It is assumed that the product will be installed according to the manufacturer's instructions or (in absence of such instructions) according to the usual practice of the building professionals.

Relevant manufacturer's stipulations having influence on the performance of the product covered by this European Assessment Document shall be considered for the determination of the performance and detailed in the ETA.

1.2 Information on the intended use(s) of the construction product

1.2.1 Intended use(s)

Structural finger jointed wet and cold glued solid timber is used in load-bearing timber structures in service classes 1 and 2 according to EN 1995-1-1 as battens.

The use is limited to static and quasi-static (non-fatigue) actions.

The EAD covers

- structural finger jointed timber, which is applied with a moisture content of ≤ 20 % in use.
- battens made from structural finger jointed wet and cold glued solid timber with a maximum span of 1,0 m.

1.2.2 Working life/Durability

The assessment methods included or referred to in this EAD have been written based on the manufacturer's request to take into account a working life of the structural finger jointed timber for the intended use of 50 years when installed in the works (provided that the structural finger jointed timber is subject to appropriate installation (see 1.1)). These provisions are based upon the current state of the art and the available knowledge and experience.

When assessing the product, the intended use as foreseen by the manufacturer shall be taken into account. The real working life may be, in normal use conditions, considerably longer without major degradation affecting the basic requirements for works¹.

The indications given as to the working life of the construction product cannot be interpreted as a guarantee neither given by the product manufacturer or his representative nor by EOTA when drafting this EAD nor by the Technical Assessment Body issuing an ETA based on this EAD, but are regarded only as a means for expressing the expected economically reasonable working life of the product.

¹ The real working life of a product incorporated in a specific works depends on the environmental conditions to which that works is subject, as well as on the particular conditions of the design, execution, use and maintenance of that works. Therefore, it cannot be excluded that in certain cases the real working life of the product may also be shorter than referred to above.

2 ESSENTIAL CHARACTERISTICS AND RELEVANT ASSESSMENT METHODS AND CRITERIA

2.1 Essential characteristics of the product

Table 1 shows how the performance of structural finger jointed timber is assessed in relation to the essential characteristics.

Table 1 Essential characteristics of the product and methods and criteria for assessing the performance of the product in relation to those essential characteristics

No	Essential characteristic	Assessment method	Type of expression of product performance
Basic Works Requirement 1: Mechanical resistance and stability			
1	Strength and stiffness properties of timber	See clause 2.2.1	Description, level
2	Bending strength of finger joints as bending strength of timber	See clause 2.2.2	Description, level
3	Durability of bonding strength	See clause 2.2.3	Description, level
4	Durability against biological attack	See clause 2.2.4	Description, level
Basic Works Requirement 2: Safety in case of fire			
5	Reaction to fire	See clause 2.2.5	Class
Basic Works Requirement 3: Hygiene, health and the environment			
6	Content, emission and/or release of dangerous substances	See clause 2.2.6	Description

2.2 Methods and criteria for assessing the performance of the product in relation to essential characteristics of the product

2.2.1 Strength and stiffness properties of timber

The structural finger jointed timber members are strength graded according to EN 14081-1.

As provided in EN 15497:2014, clause 5.1.3 the bending strength of the finger jointed timber shall be equal to or greater than the declared characteristic bending strength of the solid timber.

2.2.2 Bending strength of finger joints as bending strength of timber

The described tests shall be performed with paired test samples from the same timber source.

The following tests shall be carried out:

1. Determination of reference bending strength of the solid timber

The reference flat-wise characteristic bending strength of the structural solid timber shall be determined according to EN 408 with the exception that the test samples shall be conditioned according to Table 2.1.

The density of the test specimen shall be determined according to EN 408:2010+A1:2012, section 7 and the moisture content according to EN 13183-1. Both characteristics shall be reported.

Table 2.1: Test series for the determination of reference bending strength of the solid timber

Line	Moisture content at testing	Minimum number of test specimens	
		Smallest cross section	Largest cross section
	%		
1	approx. 12	40	40
2	approx. 25 – 30	40	40

- If only the gluing and curing temperature deviates from the requirements according to EN 15497 the test series specified in Table 2.1, Line 1, shall be carried out.

The reference flat-wise characteristic bending strength of the solid timber shall be assessed according to EN 14358. The characteristic values of the test samples act as references for the characteristic bending strength of the finger jointed timber.

2. Determination of bending strength of the finger jointed timber

The flat-wise characteristic bending strength of the structural finger jointed timber shall be determined according to EN 15497:2014, Annex C with the exception that the test samples shall be conditioned according to Table 2.2. After gluing the test samples should be stored for a minimum of 24 hours at the gluing and curing temperature according to Table 2.2.

The density of the test specimen shall be determined according to EN 408:2010+A1:2012, section 7 and the moisture content according to EN 13183-1. Both characteristics shall be reported.

Table 2.2: Test series for the determination of the bending strength of the finger jointed timber

Line	Temperature of the finger jointed timber during gluing and curing	Moisture content at gluing and testing		Minimum number of test specimens	
		Timber adherend 1	Timber adherend 2	Smallest cross section	Largest cross section
	°C	%			
1	20	approx. 12	approx. 25 - 30	20	20
2		approx. 25 - 30	approx. 25 - 30	20	20
3	$T = T_{\min} - 5 \text{ °C}$	approx. 12	approx. 12	20	20
4		approx. 12	approx. 25 - 30	20	20
5		approx. 25 - 30	approx. 25 - 30	20	20

T_{min} is the temperature of the finger jointed timber during gluing and curing used by the producer in the manufacturing.

The flat-wise characteristic bending strength of the structural finger jointed timber shall be assessed according to EN 15497:2014, Annex C. As provided in EN 15497:2014, clause 5.1.3 the characteristic value shall be higher than or equal to the reference value, here taken as the characteristic bending strength of the solid timber with corresponding cross section and moisture content, see point 1. For the finger jointed test series with one adherend with approx. 12 % and the other adherend with approx. 25 – 30 % (Lines 1 and 4 in Table 2.2) the characteristic bending strength of the solid wood series with a moisture content of approx. 25 – 30 % (Line 2 in Table 2.2) shall be used as reference value.

3. Determination of the residual bending strength of the finger jointed timber glued of jointing components with maximum permissible moisture difference

Finger jointed timber of the largest cross section shall be composed of a wet adherend with a moisture content of approx. 25 % - 30 % and two dry adherends with a moisture content of approx. 12 %. The wet adherend shall be located between the two dry adherends. The length of the adherends shall be approx. 1 m to 2,5 m. The total length of the finger jointed test piece shall be approx. 4 m to 5 m. The timber temperature of the finger jointed test pieces shall be $T_{min} - 5$ °C during gluing, where T_{min} is the temperature of the finger jointed timber during gluing and curing used by the producer in the manufacturing. The finger jointed test piece shall be fixed to a web of timber beams with a spacing of approx. 1 m by means of mechanical fasteners (screws or nails). The finger jointed test pieces shall be loaded by dead loads of approximately 0,75 kN/m². The loaded assembly of timber beams shall be dried in a climate of approx. 20°C / 30 % - 40 % relative air humidity (rh). If a moisture content of less than 10% is achieved the residual flat-wise bending strength of the finger jointed timber shall be determined. 20 finger jointed pieces shall be tested.

If only the gluing and curing temperature deviates from the requirements according to EN 15497 this test need not be carried out.

The bending strength of the finger jointed timber after exposure to the above given drying climate shall be assessed according to EN 15497:2014, Annex C. As provided in EN 15497:2014, clause 5.1.3 the characteristic value shall be higher than or equal to the reference value, here taken as the characteristic bending strength of the solid timber with largest cross section and moisture content of approx. 12 %, see subitem 1.

2.2.3 Durability of bonding strength

Additionally to EN 15497:2014, clause 5.2.3.3 the following tests shall be carried out.

1. Determination of longitudinal tensile shear strength

The longitudinal tensile shear strength test shall be carried out according to EN 302-1 with the treatments prior to tensile shear testing A1 - A5 and A7 according to EN 302-1:2013, Table 1. The test pieces shall have at gluing a moisture content according to Table 2.3. After gluing the test samples shall be stored for a minimum of 24 hours at the gluing and curing temperature according to Table 2.3. Before testing the test pieces shall be conditioned to a moisture content of (12 ± 1) %.

Table 2.3: Test series for the determination of longitudinal tensile shear strength

Line	Glue line thickness	Temperature of the finger jointed timber during gluing and curing	Moisture content at gluing	
			Wood adherend 1	Wood adherend 2
	mm	°C	%	
1	0,1	20	12 ± 1	12 ± 1
2			12 ± 1	approx. 25 - 30
3			approx. 25 - 30	approx. 25 - 30
4		T = T _{min} – 5 °C	12 ± 1	12 ± 1
5			12 ± 1	approx. 25 - 30
6			approx. 25 - 30	approx. 25 - 30
7	0,3	20	12 ± 1	12 ± 1
8			12 ± 1	approx. 25 - 30
9			approx. 25 - 30	approx. 25 - 30
10		T = T _{min} – 5 °C	12 ± 1	12 ± 1
11			12 ± 1	approx. 25 - 30
12			approx. 25 - 30	approx. 25 - 30

T_{min} is the temperature of the finger jointed timber during gluing and curing used by the producer in the manufacturing.

- If only the moisture content deviates from the requirements according to EN 15497 the test series specified in Table 2.3, Lines 1-3 and Lines 7-9, shall be carried out.
- If only the gluing and curing temperature deviates from the requirements according to EN 15497 the test series specified in Table 2.3, Lines 1, 4, 7 and 10, shall be carried out.
- If the moisture content and the gluing and curing temperature deviate from the requirements according to EN 15497 the test series specified in Table 2.3, Lines 1, 4 - 6, 7 and 10 - 12, shall be carried out.

The requirements according to EN 301:2013, clause 5.2 shall be fulfilled.

2. Static load test of multiple bondline specimens in compression shear

The test shall be carried out according to EN 15416-2. Deviating from EN 15416-2 the test pieces are made from the softwood that shall be used with a normal density ($u = 12\%$) in the range of 400 to 550 kg/m³ for spruce and fir and 500 to 650 kg/m³ for scots pine redwood, respectively. The applied shear stress in the glue lines shall be 2,5 N/mm² instead of 3,0 N/mm². The test pieces shall have at gluing a moisture content according to Table 2.4. After gluing the test samples should be stored for a minimum of 24 hours at the gluing and curing temperature according to Table 2.4. Before testing the test pieces shall be conditioned to a moisture content of (12 ± 1) %.

Table 2.4: Test series for the static load test of multiple bondline specimens in compression shear

Line	Temperature of the finger jointed timber during gluing and curing	Moisture content at gluing	
		Outer lamellae	Inner lamellae
	°C	%	
1	20	12 ± 1	approx. 25 - 30
2		approx. 25 - 30	approx. 25 - 30
3	T = T _{min} – 5 °C	12 ± 1	12 ± 1
4		12 ± 1	approx. 25 - 30
5		approx. 25 - 30	approx. 25 - 30

T_{min} is the temperature of the finger jointed timber during gluing and curing used by the producer in the manufacturing.

- If only the moisture content deviates from the requirements according to EN 15497 the test series specified in Table 2.4, Lines 1 - 2, shall be carried out.
- If only the gluing and curing temperature deviates from the requirements according to EN 15497 the test series specified in Table 2.4, Line 3, shall be carried out.
- If the moisture content and the gluing and curing temperature deviate from the requirements according to EN 15497 the test series specified in Table 2.4, Lines 4 - 5, shall be carried out.

The requirements according to EN 15425:2008, clause 5.6 shall be fulfilled.

3. Determination of curing time

The curing time of the adhesive shall be determined according to EN 302-6.

If the gluing and curing temperature reaches less than 15 °C additional tests according to EN 302-6 shall be carried out. The test pieces shall be made according to Table 2.5.

Table 2.5: Test series for the determination of curing time

Line	Glue line thickness	Temperature of the finger jointed timber during gluing and curing	Moisture content at gluing
	mm		
1	0,1	T _{min}	8
2			12

T_{min} is the temperature of the finger jointed timber during gluing and curing used by the producer in the manufacturing.

The test results shall be assessed according to EN 302-6. The curing time shall be stated in the ETA.

4. Determination of the working life

The initial viscosity of the adhesive shall be determined following EN 302-7. If the gluing and curing temperature reaches below 15°C tests according to EN 302-7 shall be carried out, performed at the minimum gluing and curing temperature used by the producer in the manufacturing T_{min}.

The test results shall be assessed according to EN 302-7. The working life shall be stated in the ETA.

2.2.4

2.2.4 Durability against biological attack

The natural durability against biological attack shall be assessed according to EN 15497:2014, clause 5.3.1. The durability of timber treated against biological attack shall be verified and assessed according to EN 15497:2014, clause 5.3.2.

2.2.5 Reaction to fire

The class of reaction to fire performance of the structural finger jointed, wet and cold glued timber (including the additional classification on smoke production and flaming droplets/particles, if any), either preservative treated against biological attack or not, shall be determined and declared by either method 1 or 2, as follows. The influence of a preservative treatment against biological attack on the performance of reaction to fire shall be taken into account as laid down in EN 15228:2009, 4.4.)

Method 1

The structural finger jointed timber shall be tested using the test method(s) relevant for the corresponding reaction to fire class in order to be classified according to EN 13501-1. The provisions in EN 15497:2014, clause 5.5 apply.

Method 2

The structural finger jointed timber is considered to satisfy the requirements for performance class D-s2, d0 of the characteristic reaction to fire in accordance with the EC Decision 2003/43/EC without the need for testing on the basis of it fulfilling the conditions set out in that Decision and its intended use being covered by that Decision.

Therefore the performance of the product is D-s2,d0.

The product shall be classified either according to EN 13501-1 in connection with Commission Delegated Regulation (EU) 2016/364 or according to method 2 without the need for further testing.

2.2.6 Content, emission and/or release of dangerous substances

The performance of the product related to the emissions and/or release and, where appropriate, the content of dangerous substances will be assessed on the basis of the information provided by the manufacturer² after identifying the release scenarios (in accordance with EOTA TR 034 **Error! Reference source not found.**taking into account the intended use of the product and the Member States where the manufacturer intends his product to be made available on the market.

The identified intended release scenarios for this product and intended use with respect to dangerous substances are:

IA 1: Product with direct contact to indoor air.

IA 2: Product with indirect contact to indoor air (e.g covered products) but possible impact on indoor air.

² The manufacturer may be asked to provide to the TAB the REACH related information which he must accompany the DoP with (cf. Article 6(5) of Regulation (EU) No 305/2011).

The manufacturer is **not** obliged:

- to provide the chemical constitution and composition of the product (or of constituents of the product) to the TAB, or
- to provide a written declaration to the TAB stating whether the product (or constituents of the product) contain(s) substances which are classified as dangerous according to Directive 67/548/EEC and Regulation (EC) No 1272/2008 and listed in the "Indicative list on dangerous substances" of the SGDS.

Any information provided by the manufacturer regarding the chemical composition of the products may not be distributed to EOTA or to TABs.

SVOC and VOC

For the intended use covered by the release scenarios IA1 and IA2 semi-volatile organic compounds (SVOC) and volatile organic compounds (VOC) are to be determined in accordance with EN 16516. The loading factor to be used for emission testing is $0,05 \text{ m}^2/\text{m}^3$.

The preparation of the test specimen is performed by use of the structural finger jointed timber with maximum depth, maximum width and for each adhesive using the maximum glue line thickness. The test specimen represents the maximum number of possible bondlines.

Once the test specimen has been produced, as described above, it should immediately be placed in the emission test chamber. This time is considered the starting time of the emission test.

The test results have to be reported for the relevant parameters (e.g. chamber size, temperature and relative humidity, air exchange rate, loading factor, size of test specimen, used adhesive, conditioning, production date, arrival date, test period, test result) after 3 and 28 days testing.

The relevant product performances shall be expressed in $[\text{mg}/\text{m}^3]$ and stated in the ETA.

3 ASSESSMENT AND VERIFICATION OF CONSTANCY OF PERFORMANCE

3.1 System(s) of assessment and verification of constancy of performance to be applied

For the products covered by this EAD the applicable European legal act is: Commission decision 97/176/EC.

The system is: 1

3.2 Tasks of the manufacturer

The cornerstones of the actions to be undertaken by the manufacturer of the product in the procedure of assessment and verification of constancy of performance are laid down in Table 3.1.

Table 3.1 Control plan for the manufacturer; cornerstones

No	Subject/type of control	Test or control method	Criteria, if any	Minimum number of samples	Minimum frequency of control
Factory production control (FPC) [including testing of samples taken at the factory in accordance with a prescribed test plan]					
1	Strength, stiffness and density properties of timber	2.2.1	EN 14081-1: 2005+A1: 2011, 6.3	Each piece of structural solid timber	EN 14081-1: 2005+A1:2011, 6.3
2	Finger joints in timber	3.4.2	EN 15497: 2014, clause 5.1.3	4 samples taken at random for each strength class or declared characteristic bending strength, species and adhesive	per shift and production line
3	Species	See control plan	Species as mentioned in 1.1	-	For each delivery
4	Adhesive	See control plan	Adhesive as mentioned in 1.1	-	For each delivery
5	Moisture content	3.4.1	Moisture content as mentioned in 1.1	Each structural solid timber	Control for each piece of solid timber before gluing
6	Reaction to fire	For method 1: Check that the relevant parameters of the tests are fulfilled For method 2: Control the minimum mean density, minimum overall thickness		1	per shift

No	Subject/type of control	Test or control method	Criteria, if any	Minimum number of samples	Minimum frequency of control
7	Species or preservative treatment of timber	Check the species or the preservative treatment according to EN 15228: 2009, 5.3		-	For each delivery
8	Formaldehyde	Control for each delivery that only adhesives for which an initial classification according to EN 15497:2014, Annex A has been carried out within the type testing are used	Class E1 or E2	-	For each delivery

3.3 Tasks of the notified body

The cornerstones of the actions to be undertaken by the notified body of the product in the procedure of assessment and verification of constancy of performance are laid down in Table 3.2.

Table 3.2 Control plan for the notified body; cornerstones

No	Subject/type of control	Test or control method	Criteria, if any	Minimum number of samples	Minimum frequency of control
Initial inspection of the manufacturing plant and of factory production control					
1	Inspection of the factory and the factory production control of the manufacturer as described in the control plan	Control of devices and equipments and the documentation of the FPC	see control plan	-	When starting the production process or when starting a new production line
Continuous surveillance, assessment and evaluation of factory production control					
2	Surveillance, assessment and approval of the factory production control of the manufacturer as described in the control plan including an annual inspection of the factory	Control of the documentation of the FPC		-	Twice a year

3.4

3.4 Special methods of control and testing used for the assessment and verification of constancy of performance

3.4.1 Measurement of moisture content of the structural solid timber

The moisture content of the structural solid timber shall be measured according to EN 15497:2014, Annex D. If the moisture content of the structural solid timber exceeds 20 % it is sufficient to use a moisture meter with an accuracy of ± 5 %.

3.4.2 Bending tests of finger joints

The flatwise bending tests shall be performed according to EN 15497, Annex C. Deviating from EN 15497, the number of specimens shall be 4 per shift and production line and taken at random for each combination of strength class or manufacturer specific strength class, species and adhesive. The flatwise bending strength shall be taken as tested.

If the declared bending strength refers to the reference height of 150 mm, the required value is equal to the declared value multiplied by k_h according to EN 384.

4 REFERENCE DOCUMENTS

As far as no edition date is given in the list of standards thereafter, the standard in its current version at the time of issuing the European Technical Assessment is of relevance.

EN 301:2013	Adhesives, phenolic and aminoplastic, for load-bearing timber structures – Classification and performance requirements
EN 302-1:2013	Adhesives for load-bearing timber structures – Test methods – Part 1: Determination of longitudinal tensile shear strength
EN 302-6:2013	Adhesives for load-bearing timber structures – Test methods – Part 6: Determination of the minimum pressing time under referenced conditions
EN 302-7:2013	Adhesives for load-bearing timber structures – Test methods – Part 7: Determination of the working life under referenced conditions
EN 336:2013-12	Structural timber – Sizes, permitted deviations
EN 338:2009	Structural timber – Strength classes
EN 350-1:1994	Durability and wood-based products – Natural durability of solid wood – Part 1: Guide to the principles of testing and classification of the natural durability of wood
EN 350-2:1994	Durability and wood-based products – Natural durability of solid wood – Part 2: Guide to the natural durability and treatability of selected wood species of importance in Europe
EN 384	Structural timber – Determination of characteristic values of mechanical properties and density
EN 408:2010+A1:2012	Timber structures – Structural timber and glued laminated timber – Determination of some physical and mechanical properties
EN 1912	Structural timber – Strength classes – Assignment of visual grades and species
EN 1995-1-1	Eurocode 5: Design of timber structures – Part 1-1: General – Common rules and rules for buildings
EN 13183-1:2002	Moisture content of a piece of sawn timber - Part 1: Determination by oven dry method
EN 13501-1:2007+A1:2009	Fire classification of construction products and building elements – Part 1: Classification using data from reaction to fire tests
EN 14080:2013	Timber structures – Glued laminated timber and glued solid timber – Requirements
EN 14081-1:2005+A1:2011	Timber structures – Strength graded structural timber with rectangular cross section – Part 1: General requirements
EN 15228:2009	Structural timber – Structural timber preservative treated against biological attack
EN 15416-2:2007	Adhesives for load bearing timber structures other than phenolic and aminoplastic – Test methods – Part 2: Static load test of multiple bondline specimens in compression shear
EN 15425	Adhesives – One component polyurethane for load bearing timber structures – Classification and performance requirements
EN 15497:2014	Structural finger jointed solid timber – Performance requirements and minimum production requirements
EN 16516:2017	Construction products – Assessment of release of dangerous substances – Determination of emissions into indoor air
EOTA Technical Report TR 034	General checklist for EADs/ETAs – Content and/or release of dangerous substances in construction products