



EUROPEAN ASSESSMENT DOCUMENT

EAD 200035-00-0302

December 2016

ROOF AND WALL SYSTEMS
WITH HIDDEN FASTENINGS

The reference title and language for this EAD is English. The applicable rules of copyright refer to the document elaborated in and published by EOTA.

This European Assessment Document (EAD) has been developed taking into account up-to-date technical and scientific knowledge at the time of issue and is published in accordance with the relevant provisions of Regulation (EU) No 305/2011 as a basis for the preparation and issuing of European Technical Assessments (ETA).

Contents

1	Scope of the EAD.....	4
1.1	Description of the construction product	4
1.2	Information on the intended use(s) of the construction product	5
1.2.1	Intended use(s).....	5
1.2.2	Working life/Durability.....	5
2	Essential characteristics and relevant assessment methods and criteria.....	6
2.1	Essential characteristics of the product	6
2.2	Methods and criteria for assessing the performance of the product in relation to essential characteristics of the product	8
2.2.1	Profiled sheeting.....	8
2.2.2	Hidden fastenings.....	9
2.2.3	Fasteners.....	9
2.2.4	Reaction to fire	15
2.2.5	External fire performance of roofs	15
2.2.6	Dead load and moment of inertia of profiled sheeting	16
2.2.7	Water tightness of standing seams or ribs (protection against driving rain)	16
2.2.8	Water permeability	16
3	ASSESSMENT AND VERIFICATION OF CONSTANCY OF PERFORMANCE	17
3.1	Systems of assessment and verification of constancy of performance to be applied	17
3.2	Tasks of the manufacturer	17
3.3	Tasks of the notified body	18
4	Reference documents	20
ANNEX A	ROOF AND WALL SYSTEMS – EXAMPLES.....	21
ANNEX B	HIDDEN FASTENINGS – EXAMPLES.....	22
ANNEX C	PROFIELD SHEETING – TEST SETUPS.....	23
ANNEX D	HIDDEN FASTENINGS – TEST SETUP	27
ANNEX E	SAMPLES FOR FASTENING SCREWS AND CORRESPONDING CONNECTIONS	28
ANNEX F	SAMPLES FOR FASTENING SCREWS AND CORRESPONDING CONNECTIONS	29
ANNEX G	FASTENER: TYPES OF CONNECTION AND CORRESPONDING LOADING CONDITIONS.....	30
ANNEX H	FASTENER: TEST SETUP FOR PULL-THROUGH TESTS TEST SETUP FOR PULL-OUT TESTS	31
ANNEX I	FASTENER: TEST SETUP FOR SHEAR TESTS	32

1 SCOPE OF THE EAD

1.1 Description of the construction product

The product is a kit comprising prefabricated roof and wall elements made of profiled sheeting with closed standing seams or ribs, hidden fastenings and fasteners. The profiled sheeting complies either with EN 14782 or EN 1090-1 or is specified in the ETA according to the provisions in this European Assessment Document.

The roof and wall elements are connected to each other by crimping or clamping the standing seams or ribs.

The hidden fastenings are connected to the standing seams or ribs of the roof and wall elements either by crimping the standing seams or ribs or by clamping. The hidden fastenings are connected to the loadbearing substructure (made of metal (aluminium, steel) or timber, oriented strand boards particleboards) by fasteners.

Annexes A and B shows typical examples of roof or wall elements and hidden fastenings. Other types of roof or wall elements and hidden fastenings are possible and common practice.

The profiled sheeting, the hidden fastenings and the fastening screws are made of metal.

The product is not fully covered by the following harmonised technical specifications: EN 14782, EN 1090-1.

Concerning product packaging, transport, storage, maintenance, replacement and repair it is the responsibility of the manufacturer to undertake the appropriate measures and to advise his clients on the transport, storage, maintenance, replacement and repair of the product as he considers necessary.

It is assumed that the product will be installed according to the manufacturer's instructions or (in absence of such instructions) according to the usual practice of the building professionals.

Relevant manufacturer's stipulations having influence on the performance of the product covered by this European Assessment Document shall be considered for the determination of the performance and detailed in the ETA.

1.2 Information on the intended use(s) of the construction product

1.2.1 Intended use(s)

The products are intended to be used as roof and wall element systems.

In certain cases the roof and wall elements could be taken as loadbearing substructures for e.g. solar construction.

1.2.2 Working life/Durability

The assessment methods included or referred to in this EAD have been written based on the manufacturer's request to take into account a working life of the roof and wall systems with hidden fastenings for the intended use of 50 years when installed in the works (provided that the roof and wall systems with hidden fastenings is subject to appropriate installation (see 1.1)). These provisions are based upon the current state of the art and the available knowledge and experience.

When assessing the product the intended use as foreseen by the manufacturer shall be taken into account. The real working life may be, in normal use conditions, considerably longer without major degradation affecting the basic requirements for works¹.

The indications given as to the working life of the construction product cannot be interpreted as a guarantee neither given by the product manufacturer or his representative nor by EOTA when drafting this EAD nor by the Technical Assessment Body issuing an ETA based on this EAD, but are regarded only as a means for expressing the expected economically reasonable working life of the product.

¹ The real working life of a product incorporated in a specific works depends on the environmental conditions to which that works is subject, as well as on the particular conditions of the design, execution, use and maintenance of that works. Therefore, it cannot be excluded that in certain cases the real working life of the product may also be shorter than the working life referred to above.

2 ESSENTIAL CHARACTERISTICS AND RELEVANT ASSESSMENT METHODS AND CRITERIA

2.1 Essential characteristics of the product

Table 1 shows how the performance of roof and wall systems with hidden fastenings is assessed in relation to the essential characteristics.

Table 1 Essential characteristics of the product and methods and criteria for assessing of the performance of the product in relation to those essential characteristics

No	Essential characteristic	Assessment method	Type of expression of product performance
Basic Works Requirement 1: Mechanical resistance and stability			
1	<p>Roof and wall elements made of profiled sheeting with closed standing seams or ribs</p> <p>Resistances for uplift and for downward load:</p> <p>$M_{c,Rk}$: bending moment resistances</p> <ul style="list-style-type: none"> - $M_{c,Rk,F}$: span moment resistance - $M_{c,Rk,B}$: maximum intermediate support moment resistance - $M^0_{Rk,B}$: theoretical maximum intermediate support moment resistance <p>$R_{w,Rk}$: transverse resistance</p> <ul style="list-style-type: none"> - $R_{w,Rk,A}$: transverse resistance of end support reaction - $R_{w,Rk,B}$: maximum transverse resistance of intermediate support reaction - $R^0_{Rk,B}$: theoretical maximum transverse resistance of intermediate support reaction 	2.2.1	Level (I_{ef} ; $M_{c,Rk,F}$; $R_{w,Rk,A}$; $M^0_{Rk,B}$; $R^0_{Rk,B}$; $M_{c,Rk,B}$; $R_{w,Rk,B}$)

No	Essential characteristic	Assessment method	Type of expression of product performance
2	Accessibility	2.2.1	Level (span compatible with single load of 1,2 kN) Level (span compatible with single load of 1,2 kN and single failure load $\geq 2,0$ kN)
3	Hidden fastenings compression resistance - axial tension resistance of the connection between hidden fastenings and profiled sheeting - connecting resistance to substructure	2.2.2	Level
4	Fasteners - shear resistance of connection - tension resistance of connection - Design resistance in case of combined tension and shear forces (interaction)	2.2.3	Level
Basic Works Requirement 2: Safety in case of fire			
5	Reaction to fire for elements made of metal	2.2.4	Class
6	External fire performance of roof elements	2.2.5	Class
Basic Works Requirement 4: Safety and accessibility in use			
7	Profiled sheeting Dead load - g: dead load Moment of inertia for uplift and for downward load - I_{ef} : effective moment of inertia	2.2.6	Level (g; I_{ef})
8	Water tightness	2.2.7	Description
9	Water permeability	2.2.8	Description

2.2 Methods and criteria for assessing the performance of the product in relation to essential characteristics of the product

2.2.1 Profiled sheeting

2.2.1.1 Resistances

The characteristic resistances of the profiled sheeting ($M_{c,Rk,F}$; $R_{w,Rk,A}$; $M_{c,Rk,B}$; $R_{w,Rk,B}$ with indices F: span; A: end support and B: intermediate support) shall be determined by tests and evaluated according to EN 1993-1-3 (Annex A), EN 1993-1-4 (clause 7) or EN 1999-1-4 (Annex A). The test setups are shown exemplarily in Annex C.

The characteristic resistances of the profiled sheeting $M^0_{Rk,B}$ and $R^0_{Rk,B}$ shall be determined as shown in figure 1.

Resistances which are not been determined by tests may be determined by interpolation considering the correct transferability of test results (e.g. material properties, geometry, component behaviour).

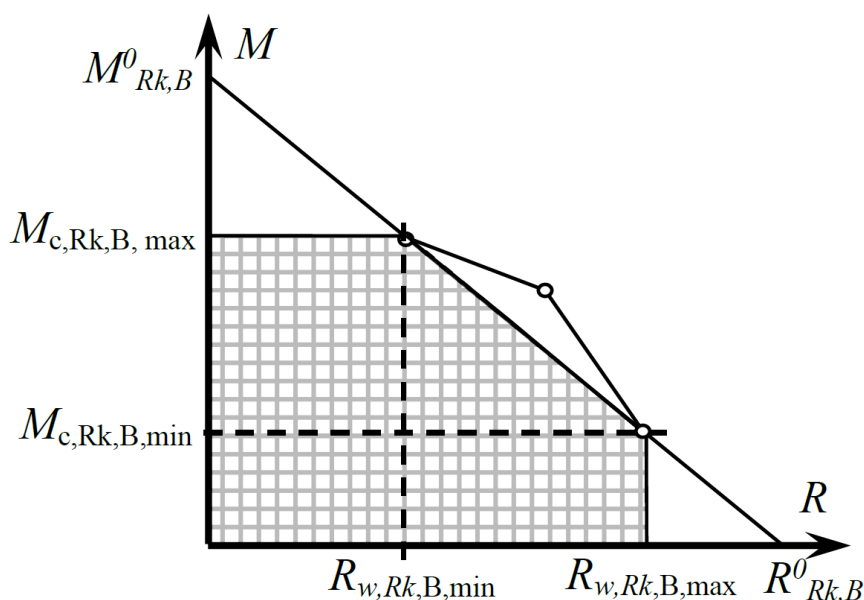

Figure 1: Diagram for resistance under combined bending moment and support reaction

2.2.1.2 Accessibility

2.2.1.2.1 Accessibility (erecting state of system)

For mechanical resistance to single loads while assembling (direct loading e.g. by person) the corresponding spans shall be determined by tests according to EN 14782 (Annex B). The profiled sheeting has to resist a maximum load of 1.2 kN (tested with open seams or joints).

2.2.1.2.2 Accessibility (final state of system)

For mechanical resistance to single loads after assembling (direct loading e.g. by person) the corresponding spans shall be determined by tests in analogy to EN 14782 (Annex B). The profiled sheeting has to resist a maximum load of 1.2 kN without damage (taking into account that damage can result in reduction of mechanical resistances and load bearing capacity; replacement is effortful). The failure load should be ≥ 2.0 kN after assembling (tested in end use condition).

2.2.2 Hidden fastenings

a) Tensile tests upon hidden fastenings in combination with profiled sheeting

To determine the characteristic axial tension resistance of the connection between hidden fastenings and profiled sheeting tests according to Annex D, figure 1 shall be carried out. At least 10 tension tests for each combination of hidden fastening and profiled sheeting shall be performed. The test load shall be increased deformation-controlled (recommendation: 5mm/min) until failure. The load-deformation curves and the failure modes as well as the material properties (yield strength, tensile strength and elongation) shall be documented in the test report. b) Tensile tests upon hidden fastenings without profiled sheeting

The rules mentioned above (see section 2.2.2 a) shall apply accordingly.

c) Axial compression tests upon hidden fastenings

To determine the characteristic compression resistance of the hidden fastenings tests according to Annex C, figure 2 shall be carried out. At least 5 compression tests for each hidden fastening considering the dimension shall be performed. The test load shall be increased deformation-controlled (recommendation: 5mm/min) until failure. The load-deformation curves and the failure modes as well as the material properties (yield strength, tensile strength and elongation) shall be documented in the test report. The test results (failure loads) shall be multiplied by a correction factor which takes account of the ratio of guaranteed minimum tensile/yield strength and the tensile/yield strength of the building components made of metal used in the tests. The corrected test results shall be evaluated statistically (determination of 5% fractiles, confidence level of 75%) according to EN 1990. The corrected and statistically evaluated test results (5% fractiles) are the characteristic values of the tested types.

The design values of resistance of hidden fastenings are the characteristic values divided by the recommended partial safety factor $\gamma_M = 1.1$ for compression and $\gamma_M = 1.33$ for tension. The recommended partial safety factors γ_M should be used in cases where no factor is given in national regulations of the member state where the hidden fastenings are used.

2.2.3 Fasteners²

2.2.3.1 Shear resistance of the connections

2.2.3.1.1 Single layer shear tests

At least 10 shear tests with single sheet layers shall be carried out for each relevant combination of sheeting thickness t_I and substructure thickness t_{II} .

In case of substructure made of oriented strand board the tests shall be carried out on a product of class OSB/2 according to EN 300 and EN 13986. In case of substructure made of particleboard the tests shall be carried out on a product of class P4 according to EN 312 and EN 13986.

The test load shall be increased until shear failure of the fastening screw, misalignment of the fastening screw of 10° or local bearing deformation (hole elongation) of the sheeting or the substructure occurs. The deformation capacity up to maximum load shall be at least 0.5 mm. For metal substructures the maximum load which shall be taken into account in order to determine the relevant characteristic resistance is the maximum load which corresponds to a deformation capacity within a range from 0.5 mm – 3.0 mm. The load-deformation curves and the respective failure modes as well as the material properties of the sheeting, the substructure and the fastener used for the tests shall be documented in the test report. Furthermore the failure loads shall be given in the test report. The material properties should be documented by means of inspection documents 3.1 according to EN 10204:2004. The material properties have to correspond to the material specifications given by the manufacturer.

An example for the test setup is shown in Annex H. The connection to be tested is the connection "Type a" according to Annex E.

² The performances stated in clause 2.2.3 can also be provided by an ETA issued on basis of EAD 3300046-01-0602.

2.2.3.1.2 Four layer shear tests

Four layer shear tests are optional tests. If they are carried out the following applies: At least 10 shear tests with 4 sheet layers shall be carried out for each relevant substructure thickness t_{II} . The test load shall be increased until shear failure of the fastening screw, misalignment of the fastening screw of 10° or local bearing deformation (hole elongation) of the sheeting or failure of the substructure. The deformation capacity up to maximum load shall be at least 0.5 mm. The rate of deformation should not exceed 1 mm/min.

In case of substructure made of oriented strand board the tests shall be carried out on a product of class OSB/2 according to EN 300 and EN 13986. In case of substructure made of particleboard the tests shall be carried out on a product of class P4 according to EN 312 and EN 13986. For metal substructures the maximum load which shall be taken into account in order to determine the relevant characteristic resistance is the maximum load which corresponds to a deformation capacity within a range from 0.5 mm – 3.0 mm. The load-deformation curves and the respective failure modes as well as the material properties of the sheeting, the substructure and the fastening screw used for the tests shall be documented in the test report. Furthermore the failure loads shall be given in the test report. The material properties should be documented by means of inspection documents 3.1 according to EN 10204:2004. The material properties have to correspond to the material specifications given by the manufacturer.

An example for the test setup is shown in Annex I. The connection to be tested is the connection "Type d" according to Annex E.

The tensile strength of the material of the component with the thickness t_I (sheeting) should be at the upper limit range according to the relevant product standard (e.g. EN 10346:2009). The maximum possible thickness of the sheeting ($4 \times t_I$) shall be used. This is the maximum thickness for sheeting fastenings where longitudinal and transverse lap joints coincide (side lap and end overlap connection; connection "Type d" according to Annex E).

2.2.3.1.3 Determination of characteristic shear resistance

The results of the tests according to 2.2.3.1.1 and 2.2.3.1.2 (failure loads or maximum loads) shall be multiplied by the following correction factor which depends on the failure mode:

local bearing of sheeting: $\alpha = (R_{m,min}/R_m) \times (t_{I,min}/t_I) \leq 1.0$

local bearing of metal substructure: $\alpha = (R_{m,min}/R_m) \times (t_{II,min}/t_{II}) \leq 1.0$

failure of timber substructure: $\alpha = \varphi/\varphi_{test} \leq 1.0$

failure of oriented strand boards or particleboard substructure: $\alpha = 1.0$

failure of fastener: $\alpha = 1.0$

with:

$R_{m,min}$ = minimum tensile strength of the relevant metal components t_I or t_{II} according to the relevant product standard

R_m = tensile strength of the relevant metal components t_I or t_{II} used for the tests

φ = nominal density of the timber

φ_{test} = density of the timber used for the test (the timber used for the test shall be conditioned in accordance with the relevant standards)

$t_{I,min}$, $t_{II,min}$ = minimum thickness of the relevant components t_I or t_{II} according to the relevant product standard

t_I , t_{II} = thickness of the relevant components t_I or t_{II} used for the tests

The corrected test results shall be evaluated statistically (determination of 5% fractile, confidence level 75%). Generally a normal distribution can be assumed.

The determination of the shear resistance depends on the type of substructure.

For metal substructures the following applies:

The corrected and statistically evaluated test results (5% fractile) are the characteristic values $V_{R,k}$ of the shear resistance of the connection.

For timber substructures the following applies:

The characteristic values $V_{R,k}$ of the shear resistance of the connections are either the corrected and statistically evaluated test results (5% fractile) or the characteristic values determined according to EN 1995-1-1. The rate of deformation should not exceed 1 mm/min.

2.2.3.1.4 Determination of design shear resistance

The determination of the shear resistance depends on the type of substructure.

For metal substructures the following applies:

The design values $V_{R,d}$ of the shear resistance are the characteristic values of the shear resistance according to 2.2.3.1.3 divided by the recommended partial safety factor $\gamma_M = 1.33$. The recommended partial safety factor γ_M should be used in cases where no factor is given in national regulations of the Member State where the fastening screws are used.

For timber and board substructures the following applies:

The design values $V_{R,d}$ of the shear resistance are the characteristic values of the shear resistance according to 2.2.3.1.3 multiplied by k_{mod} according to EN 1995-1-1:2004 + AC:2006 + A1:2008, Table 3.1, and divided by the recommended partial safety factor $\gamma_M = 1.33$. If failure of the metal component with the thickness t_i and not failure of the timber substructure is the relevant failure mode then $k_{mod} = 1.0$.

The recommended partial safety factor γ_M should be used in cases where no factor is given in national regulations of the Member State where the fastening screws are used.

2.2.3.2 Tension resistance of the connections

2.2.3.2.1 Static pull-through tests

At least 10 pull-through-tests shall be carried out for each relevant sheeting thickness t_i . The test load shall be increased until pull-through of the fastener. The respective failure modes as well as the material properties of the sheeting, the substructure and the fastener used for the tests shall be documented in the test report. Furthermore the failure loads shall be given in the test report. The material properties should be documented by means of inspection documents 3.1 according to EN 10204:2004. The material properties have to correspond to the material specifications given by the manufacturer.

In case of substructure made of oriented strand board the tests shall be carried out on a product of class OSB/2 according to EN 300 and EN 13986. In case of substructure made of particleboard the tests shall be carried out on a product of class P4 according to EN 312 and EN 13986.

An example for the test setup is shown in Annex G. The connection to be tested is the connection "Type a" according to Annex E.

The tensile strength of the material of the component with the thickness t_i (sheeting) should be at the lower limit according to the relevant product standard (e. g. EN 10346).

The material properties as well as the thickness of the substructure are optional as long as failure of the substructure is excluded.

2.2.3.2.2 Cyclic pull-through tests

Cyclic pull-through tests are additional optional tests. If they are carried out the following applies:

At least 5 cyclic pull-through test shall be carried out with a constant amplitude load. The minimum load should not be less than 10 % of the maximum load. The loading frequency should be 5 Hz. Each test specimen has to undergo 5,000 load cycles. After passing 5,000 load cycles without any failure of the connection, a static pull-through test given in 2.2.3.2.5 shall be performed. The pull-out resistance of the fastening screw after the cyclic pull-through test has to be at least 80% of the value evaluated according to the "Static Pull-through test" method given in 2.2.3.2.5. If one or more specimens fail the cyclic pull-through test or do not reach 80% of the static loading, the tests have to be repeated with a reduced load level.

The correction factor α_{cycl} is determined through

$$\alpha_{cycl} = 1,5 \times (\text{normalised load level with 5000 load changes without damage} / \text{characteristic static pull-through}) \leq 1.0$$

The material properties should be documented by means of inspection documents 3.1 according to EN 10204:2004-10. The material properties have to correspond to the material specifications given by the manufacturer.

An example for the test setup is shown in Annex G. The connection to be tested is the connection "Type a" according to Annex E.

The tensile strength of the material of the component with the thickness t_1 (sheeting) should be at the lower limit according to the relevant product standard (e. g. EN 10346).

The material properties as well as the thickness of the substructure are optional as long as failure of the substructure is excluded.

In case of substructure made of oriented strand board the tests shall be carried out on a product of class OSB/2 according to EN 300 and EN 13986. In case of substructure made of particleboard the tests shall be carried out on a product of class P4 according to EN 312 and EN 13986.

2.2.3.2.3 Pull-out tests

At least 10 pull-out-tests shall be carried out for each relevant thread engagement or substructure thickness t_{II} . The test load shall be increased until pull-out or fracture of the fastener. The respective failure modes as well as the material properties of the sheeting, the substructure and the fastener used for the tests shall be documented in the test report. Furthermore the failure loads shall be given in the test report. The material properties should be documented by means of inspection documents 3.1 according to EN 10204:2004. The material properties have to correspond to the material specifications given by the manufacturer. The rate of deformation should not exceed 5 mm/min.

In case of substructure made of oriented strand board the tests shall be carried out on a product of class OSB/2 according to EN 300 and EN 13986. In case of substructure made of particleboard the tests shall be carried out on a product of class P4 according to EN 312 and EN 13986.

An example for the test setup is shown in Annex G. The connection to be tested is the connection "Type d" according to Annex E.

The tensile strength of the material of the component with the thickness t_1 (sheeting) is optional. It should be a typical tensile strength according to the relevant product standard (e. g. EN 10346). The maximum possible thickness of the sheeting ($4 \times t_1$) shall be used. This is the maximum thickness for sheeting fastenings where longitudinal and transverse lap joints coincide (side lap and end overlap connection; connection "Type d" according to Annex E).

The material properties of the substructure should be at the lower limit according to the relevant product standard (e. g. EN 10025-1, EN 14081-1). 2.2.3.2.4 Determination of characteristic pull-through, pull-out and tension resistance

The test results of the tests according to 2.2.3.2.1, 2.2.3.2.2 and 2.2.3.2.3 (failure loads or maximum loads) shall be multiplied by the following correction factor which depends on the failure mode:

Tests according to 2.2.3.2.1 and 2.2.3.2.2:

failure of sheeting: $\alpha = (R_{m,min}/R_m) \times (t_{l,min}/t_l) \leq 1.0$

failure of fastener: $\alpha = 1.0$

Tests according to 2.2.4.2.3:

pull out failure (metal substructure): $\alpha = (R_{m,min}/R_m) \times (t_{II,min}/t_{II}) \leq 1.0$

pull out failure (timber substructure): $\alpha = \varphi/\varphi_{test} \leq 1.0$

pull out failure (oriented strand boards or particleboard substructure): $= 1.0$

Failure of fastener: $\alpha = F_{tension,min} / F_{tension} \leq 1.0$

with:

$R_{m,min}$ = minimum tensile strength of the relevant metal components t_l or t_{II} according to the relevant product standard

R_m = tensile strength of the relevant metal components t_l or t_{II} used for the tests

φ = nominal density of the timber

φ_{test} = density of the timber used for the test (the timber used for the test shall be conditioned in accordance with the relevant standards)

$t_{l,min}$, $t_{II,min}$ = minimum thickness of the relevant components t_l or t_{II} according to the relevant product standard

t_l , t_{II} = thickness of the relevant components t_l or t_{II} used for the tests

$F_{tension,min}$ = minimum tension resistance of the fastener

$F_{tension}$ = tension resistance of the fasteners used for the tests

The corrected test results shall be evaluated statistically (determination of 5% fractile, confidence level 75%). Generally a normal distribution can be assumed.

The corrected and statistically evaluated test results (5% fractile) of the tests according to 2.2.3.2.1 are the characteristic values of the static pull-through resistance of the connection.

The statistical evaluation of the results of additional optional cyclic pull-through tests according to 2.2.3.2.2 refers to the number of cycles until failure. On the basis of the 5% fractile curve of the number of cycles until failure at a certain load level, which shall be determined from the results of tests on 3 different load levels, the pull-through resistance corresponding to 5000 cycles shall be determined. The result is the characteristic value of the pull-through resistance for repeated wind loads. (Remark: Background information is given in the European Recommendations for the Design and Testing of Connections in Steel Sheeting and Sections, N° 21, May 1983, and the European Recommendations for Sandwich Panels, N° 115, January 2001.)

The characteristic value of the cyclic pull-through resistance for repeated wind loads should be determined as follows:

If no cyclic pull-through tests were carried out according to 2.2.3.2.2, the characteristic value is the characteristic value of the static pull-through resistance multiplied by the following reduction factor α_{cycl} :

$$\alpha_{cycl} = 2/3 = 0.67$$

If cyclic pull-through tests were carried out according to 2.2.3.2.2, the characteristic value is the characteristic value of the static pull-through resistance multiplied by the following reduction factor α_{cycl} :

$$\alpha_{cycl} = 1.5 \times (\text{char. cyclic pull-through resistance} / \text{char. static pull-through resistance}) \leq 1.0$$

(Remark: The factor 1.5 takes into account the different safety levels for fatigue design and design for predominantly static loads. α_{cycl} is limited to 1.0.)

The possibly required reduction of the pull-through resistance due to the position of the fastener shall be taken into account according to EN 1993-1-3, section 8.3 (7) and Fig. 8.2 or EN 1999-1-4, Table 8.3.

The determination of the pull-out resistance depends on the type of substructure.

For metal substructures the following applies:

The corrected and statistically evaluated test results (5% fractile) of the tests according to 2.2.3.2.3 are the characteristic values of the pull-out resistance of the connection.

For timber substructures the following applies:

The characteristic values of the pull-out resistance of the connections are either the corrected and statistically evaluated test results (5% fractile) of the tests according to 2.2.3.2.3 or the characteristic values determined according to EN 1995-1-1:2004 + AC:2006 + A1:2008, section 8.7..

The characteristic tension resistance $N_{R,k}$ is the minimum of the characteristic values of either pull-through resistance or relevant pull-out resistance for the corresponding connection.

2.2.3.2.5 Determination of design pull-through, pull-out and tension resistance

The design values of the pull-through resistance are the characteristic values of the pull-through resistance according to 2.2.3.2.4 divided by the recommended partial safety factor $\gamma_M = 1.33$. The recommended partial safety factor γ_M should be used in cases where no factor is given in national regulations of the Member State where the fastening screws are used.

The determination of the pull-out resistance depends on the type of substructure.

For metal substructures the following applies:

The design values of the pull-out resistance are the characteristic values of the pull-out resistance according to 2.2.3.2.4 divided by the recommended partial safety factor $\gamma_M = 1.33$. The recommended partial safety factor γ_M should be used in cases where no factor is given in national regulations of the Member State where the fastening screws are used.

For timber substructures the following applies:

The design values of the pull-out resistance are the characteristic values of the pull-out resistance according to 2.2.3.2.4 multiplied by k_{mod} according to EN 1995-1-1:2004 + AC:2006 + A1:2008, Table 3.1, and divided by the recommended partial safety factor $\gamma_M = 1.33$. The recommended partial safety factor γ_M should be used in cases where no factor is given in national regulations of the Member State where the fastening screws are used.

The design tension resistance $N_{R,d}$ is the minimum of the design values of either pull through resistance or relevant pull-out resistance for the corresponding connection.

2.2.3.3 Design resistance in case of combined tension and shear forces

In case of combined tension and shear forces the linear interaction formula according to EN 1993-1-3, section 8.3 (8) or EN 1999-1-4, section 8.1(7) should be taken into account.

2.2.3.4 Check of deformation capacity in case of constraining forces due to temperature

In order to check a sufficient deformation capacity of 3 mm in case of constraining forces due to temperature the test results of the shear tests described in 2.2.3.1.1 and 2.2.3.1.2 should be used.

2.2.4 Reaction to fire

2.2.4.1 Profiled sheeting

The profiled sheeting made of metal without any organic coating is considered to satisfy the requirements for performance class A1 of the characteristic reaction to fire, in accordance with the provisions of EC Decision 96/603/EC (as amended by EC Decisions 2000/605/EC and 2003/424/EC) without the need for testing on the basis of its listing in that decision.

The profiled sheeting made of steel with organic coating is considered to satisfy the requirements for performance class A1 or C-s3,d0 of the characteristic reaction to fire in accordance with the EC Decision 2010/737/EC without the need for testing on the basis of its fulfilling the conditions set out in that Decision and its intended use being covered by that Decision.

The profiled sheeting made of metal with organic coating not covered by EC Decision 2010/737/EC shall be tested, using the test method(s) relevant for the corresponding reaction to fire class, in order to be classified according to EN 13501-1.

The products shall be classified according to EN 13501-1.

2.2.4.2 Hidden fastenings

The hidden fastenings are considered to satisfy the requirements for performance class A1 of the characteristic reaction to fire, in accordance with the provisions of EC Decision 96/603/EC (as amended) without the need for further testing on the basis of its conformity with the specification of the product detailed in that Decision and its intended end use application being covered by that Decision.

Therefore the performance of the product is class A1 according to EN 13501-1.

2.2.4.3 Fasteners

The fasteners are considered to satisfy the requirements for performance class A1 of the characteristic reaction to fire, in accordance with the provisions of EC Decision 96/603/EC (as amended) without the need for decision. further testing on the basis of its conformity with the specification of the product detailed in that Decision and its intended end use application being covered by that Decision.

Therefore the performance of the product is class A1 according to EN 13501-1.

2.2.5 External fire performance of roofs

The roof (including the complete roof covering) in which the the roof elements with hidden fastenings are intended to be incorporated, installed or applied can be considered to fulfil all of the requirements for the performance characteristic 'external fire performance' in accordance with the EC Decision 2000/553/EC without the need for further testing on the basis of it fulfilling the conditions set out in that Decision and its intended use being covered by that Decision

The roof (including the complete roof covering) in which roof elements with hidden fastenings is intended to be incorporated, installed or applied not covered by EC Decision 2000/553/EC is considered to satisfy the requirements for performance class B_{ROOF} (t1), B_{ROOF} (t2) or B_{ROOF} (t3) of the characteristic external fire performance in accordance with the EC Decision 2005/403/EC without the need for further testing on the basis of it fulfilling the conditions set out in that Decision and its intended use being covered by that Decision.

The roof (including the complete roof covering) in which roof elements with hidden fastenings is intended to be incorporated, installed or applied not covered by EC Decision 2005/403/EC or 2000/553/EC shall be tested using the test method relevant for the corresponding external fire performance roof class, in order to be classified according to EN 13501-5.

The roof (including the complete roof covering) in which the roof elements with hidden fastenings are intended to be incorporated, installed or applied shall be classified according to EN 13501-5.

2.2.6 Dead load and moment of inertia of profiled sheeting

a) Dead load

The dead load of the profiled sheeting shall be determined by weighing or by calculation.

b) Moment of inertia

The moment of inertia shall be determined by calculation according to EN 1993-1-3 (clause 7.1), EN 1993-1-4 (clause 5) or EN 1999-1-4 (clause 7.1) or by tests referring to EN 1993-1-3 (Annex A.2), EN 1993-1-4 (clause 7) or EN 1999-1-4 (Annex A.2) according clause 2.2.1.

The determination of the moment of inertia by test shall be done on the basis of single span tests for uplift and downward load (see clause 2.2.1) and calculation by general formula of deflection at mid span position dependent of modulus of elasticity and loading. The result shall be adjusted by adjustment factor according EN 1993-1-3 (Annex A.6.2), EN 1993-1-4 (clause 7) or EN 1999-1-4 (Annex A.3.2) with term setting $(f_{yb,obs} / f_{yb})^\alpha = 1$ (term not relevant for moment of inertia).

The characteristic moment of inertia shall be evaluated according EN 1993-1-3 (Annex A.6.3), EN 1993-1-4 (clause 7) or EN 1999-1-4 (Annex A.3.3).

Moments of inertia not determined by tests may be determined by interpolation considering the correct transferability of test results (e.g. material properties, geometry, components behavior).

2.2.7 Water tightness of standing seams or ribs (protection against driving rain)

The test of water tightness of the standing seam and ribs (protection against driving rain) shall be carried out according to ETAG 034, clause 5.3.1.

The requirements according to ETAG 034 Part 1, clause 6.3.1 shall be satisfied.

2.2.8 Water permeability

Water permeability of the profiled sheeting shall be assessed according to EN 14782:2006 clause 4.4.

The requirements according to EN 14782:2006 clause 4.4 shall be satisfied.

3 ASSESSMENT AND VERIFICATION OF CONSTANCY OF PERFORMANCE

3.1 Systems of assessment and verification of constancy of performance to be applied

For the products covered by this EAD the applicable European legal act is: Decision 1998/214/EC.

The system is: **2+**.

In addition, with regard to e.g. reaction to fire for products with organic coating covered by this EAD outside the scope of 2010/737/EC the applicable European legal act is: Decision 98/214/EC.

The system is: **1**.

3.2 Tasks of the manufacturer

The cornerstones of the actions to be undertaken by the manufacturer of the product in the process of verification of constancy of performance are laid down in Table 2.

Table 2 Control plan for the manufacturer; cornerstones

No	Subject/type of control	Test or control method	Criteria, if any	Minimum number of samples	Minimum frequency of control
Factory production control (FPC) (including testing of samples taken at the factory in accordance with a prescribed test plan)					
1 Profiled sheeting and hidden fastenings					
1.1	Check of initial material	Inspection document "type 3.1" according to EN 10204 (to be furnished by the supplier) and/or CE marking	Results have to be documented	-	Each supplied coil and/or order
1.2	Geometry, dimensions and tolerances	Check of geometry, dimensions and tolerances	Results have to be documented	-	Each production unit and/or order

No	Subject/type of control	Test or control method	Criteria, if any	Minimum number of samples	Minimum frequency of control
1.3	Bending test for profiled sheeting made of aluminium	EN ISO 7438	Sufficient ductile behaviour of initial material and profiled sheeting, i.e. no appearance of cracks	-	Each supplied coil
1.4	PCS-value of organic coating of profiled sheeting	EN ISO 1716	Classification acc. EN 13501-1	1 sample per type of coating	Twice a year
1.5	Thickness of organic coating of profiled sheeting	Check of thickness	Classification acc. EN 13501-1	1 sample per type of coating	Twice a year
2 Fasteners					
2.1	Check of material properties and chemical composition stated in the ETA	Inspection document 3.1 according to EN 10204-2004 (to be furnished by the supplier)	Results have to be documented	-	Every production unit
2.2	Geometry and dimensions	Check of dimensions and tolerances	Results have to be documented	10	Every production unit
2.3	Tension resistance of fastening screws	Check according to test plan	Results have to be documented	10	Every production unit
2.4	Thread forming, drill- drive and torque tests	Check according to test plan	Results have to be documented	10	Every production unit
2.5	Check of initial raw material	Inspection document 3.1 acc. to EN 10204 (to be furnished by the supplier)	Results have to be documented	10	Every production unit

3.3 Tasks of the notified body

The cornerstones of the actions to be undertaken by the notified body in the process of constancy of performance for roof and wall system with hidden fastenings are laid down in Table 3.

Table 3 Control plan for the notified body; cornerstones

No	Subject/type of control	Test or control method	Criteria, if any	Minimum number of samples	Minimum frequency of control
Initial inspection of the manufacturing plant and of factory production control					
1 Profiled sheeting and hidden fastenings					
1.1	Check of initial material	Inspection document "type 3.1" according to EN 10204 (to be furnished by the supplier) and/or CE marking	Results have to be documented	-	When starting production or a new production line
1.2	Geometry, dimensions and tolerances	Check of geometry, dimensions and tolerances	Results have to be documented	-	When starting production or a new production line
1.3	Bending test for profiled sheeting made of aluminium	EN ISO 7438	Sufficient ductile behaviour of initial material and profiled sheeting, i.e. no appearance of cracks	-	When starting production or a new production line
2 Fasteners					
2.1	Inspection of factory and factory production control				Before certification
2.2	Inspection of the testing facilities of the manufacturer				
Continuous surveillance, assessment and evaluation of factory production control					
1 Profiled sheeting and hidden fastenings					
1.1	Surveillance and assessment of factory production control				Twice a year
1.2	Surveillance of the testing facilities of the manufacturer				
2 Fasteners					
2.1	Surveillance and assessment of factory production control				Once a year
2.2	Surveillance of the testing facilities of the manufacturer				

4 REFERENCE DOCUMENTS

As far as no edition date is given in the list of standards thereafter, the standard in its current version at the time of issuing the European Technical Assessment is of relevance.

EN 1990	Eurocode 0 Basis of structural design as amended
EN 300	Oriented strand boards (OSB) – Definition, classification and specifications
EN 312	Particleboards - Specifications
EN 1993-1-1	Eurocode 3: Design of steel structures Part 1-1: General rules and rules for buildings
EN 1993-1-3	Eurocode 3: Design of steel structures Part 1-3: General rules - Supplementary rules for cold-formed members and sheeting
EN 1993-1-4	Eurocode 3: Design of steel structures Part 1-4: General rules - Supplementary rules for stainless steels
EN 1995-1-1	Eurocode 5: Design of timber structures – Part 1-1:General – Common rules and rules for buildings
EN 1999-1-1	Eurocode 9: Design of aluminium structures – Part 1-1: General rules; general rules and rules for buildings
EN 1999-1-4	Eurocode 9: Design of aluminium structures - Part 1-4: Cold-formed structural sheeting
EN 10025	Hot rolled products of structural steels – Part 1: General technical delivery conditions
EN 10204	Metallic products – Types of inspection documents
EN 10346	Metallic products – Types of inspection documents
EN 13501-1	Fire classification of construction products and building elements - Part 1: Classification using test data from reaction to fire tests
EN 13501-5	Fire classification of construction products and building elements - Part 5: Classification using data from external fire exposure to roofs tests as amended
EN 13986	Wood-based panels for use in construction - Characteristics, evaluation of conformity and marking
EN 14782	Self-supporting metal sheet for roofing, external cladding and internal lining - Product specification and requirements
EN ISO 7438	Metallic materials - Bend test
CEN/TS 1187	Test methods for external fire exposure to roofs
EN ISO 1716	Reaction to fire tests for products - Determination of the gross heat of combustion (calorific value)
EAD 330046-01-0602	Fastening Screws for Metal Members and Sheetting

ANNEX A ROOF AND WALL SYSTEMS – EXAMPLES

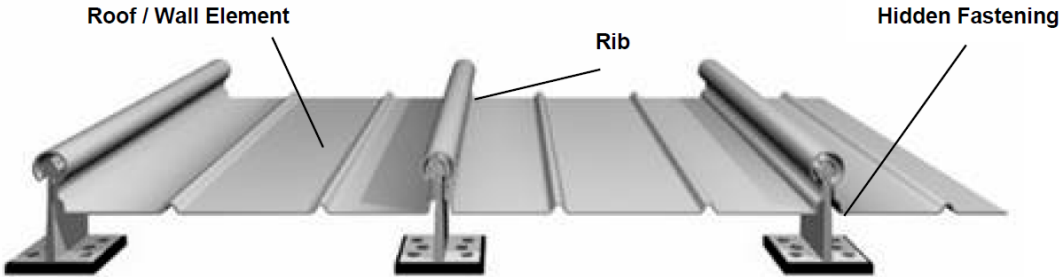

Figure 1

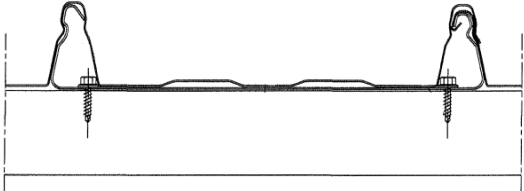

Figure 2

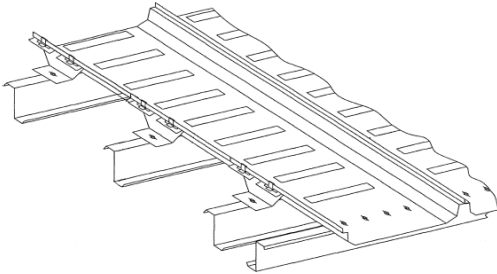

Figure 3

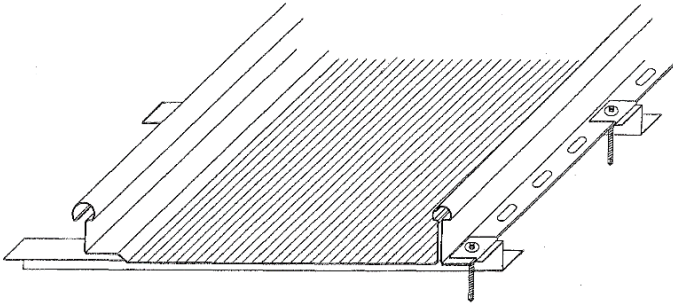

Figure 4

ANNEX B HIDDEN FASTENINGS – EXAMPLES

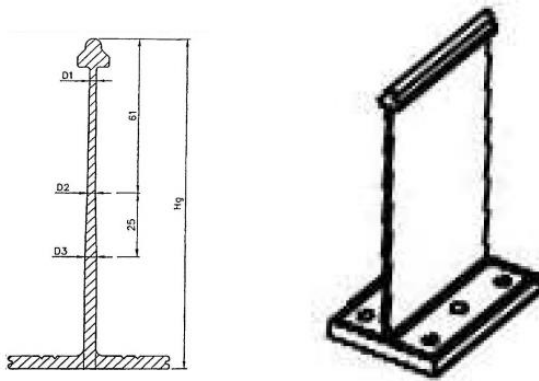

Figure 1

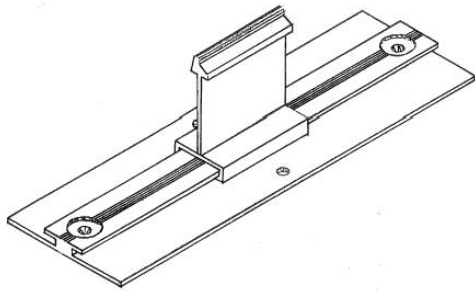

Figure 2



Figure 3

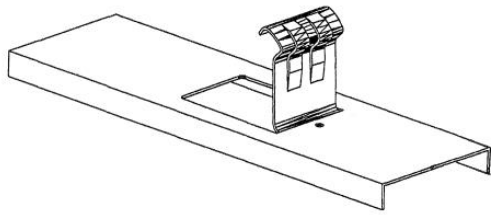

Figure 4

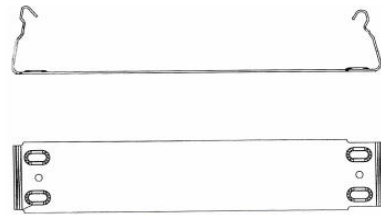

Figure 5

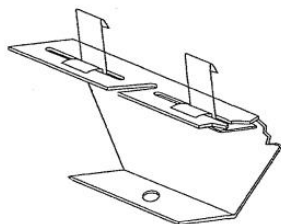

Figure 6

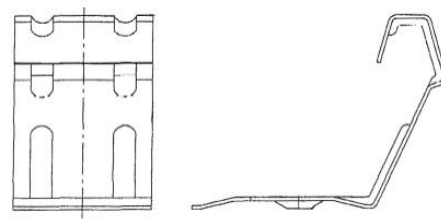

Figure 7

ANNEX C PROFIELD SHEETING – TEST SETUPS

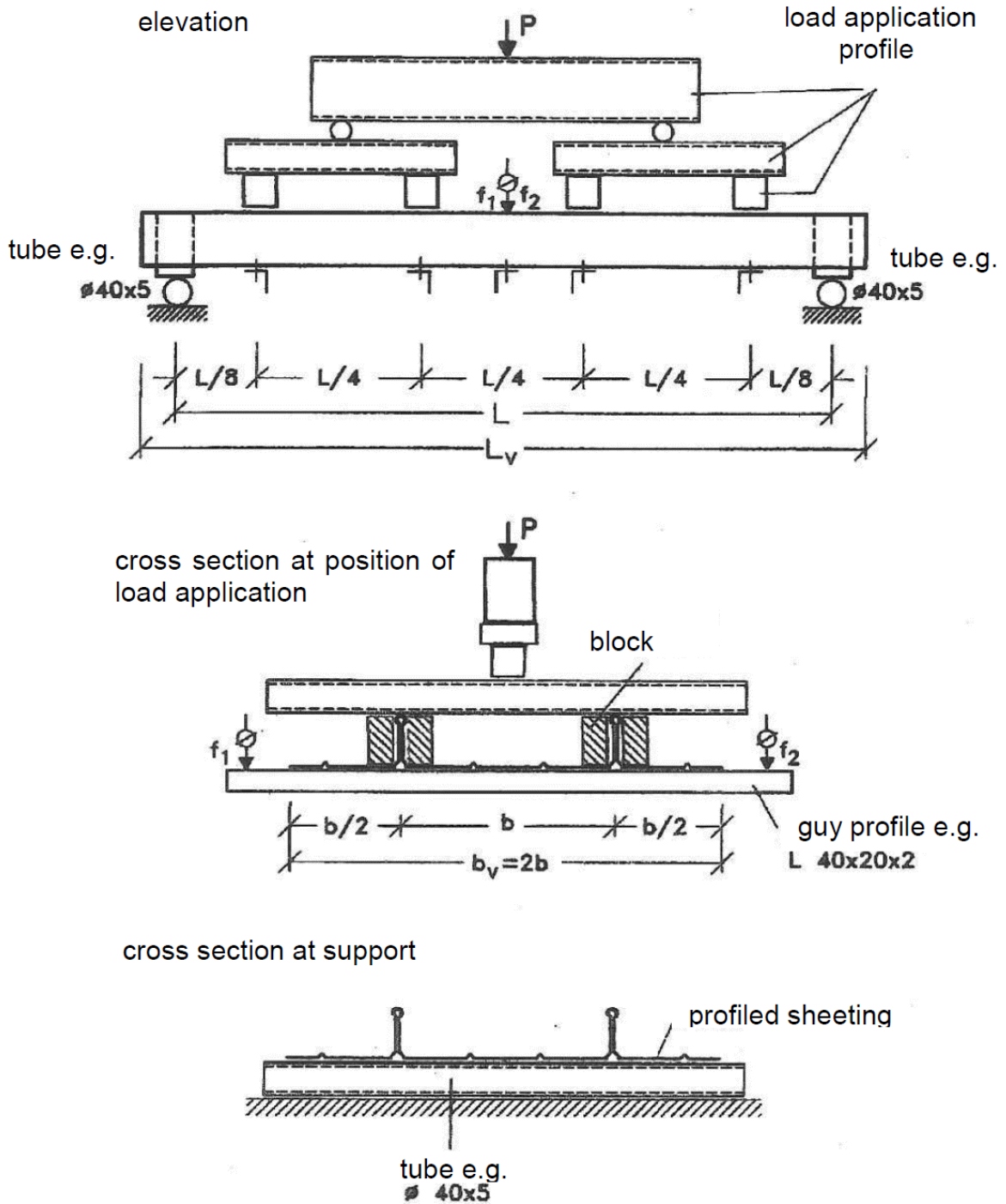

Figure 1: single span test for downward load

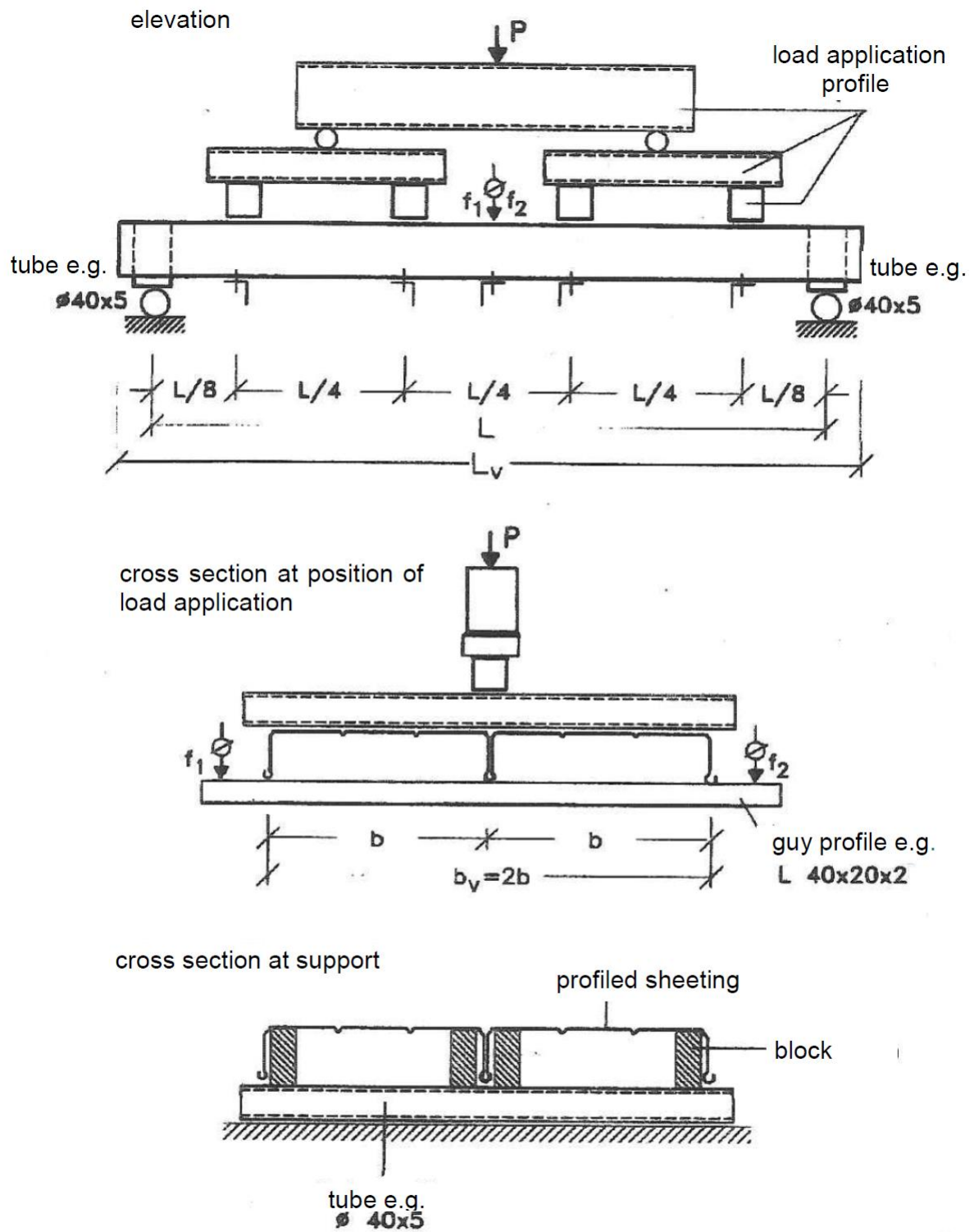

Figure 2: single span test for uplift load

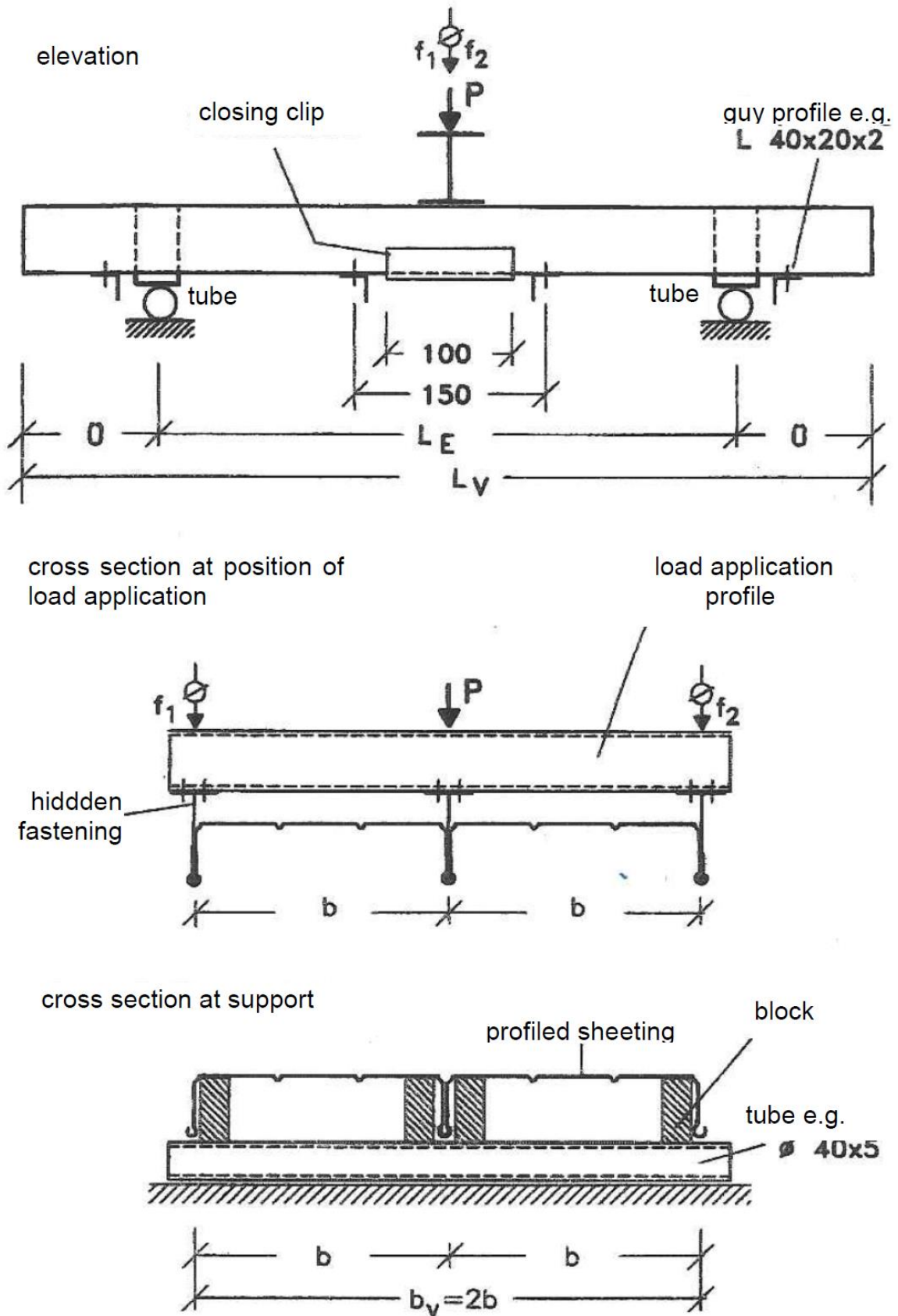

Figure 3: internal support test for downward load

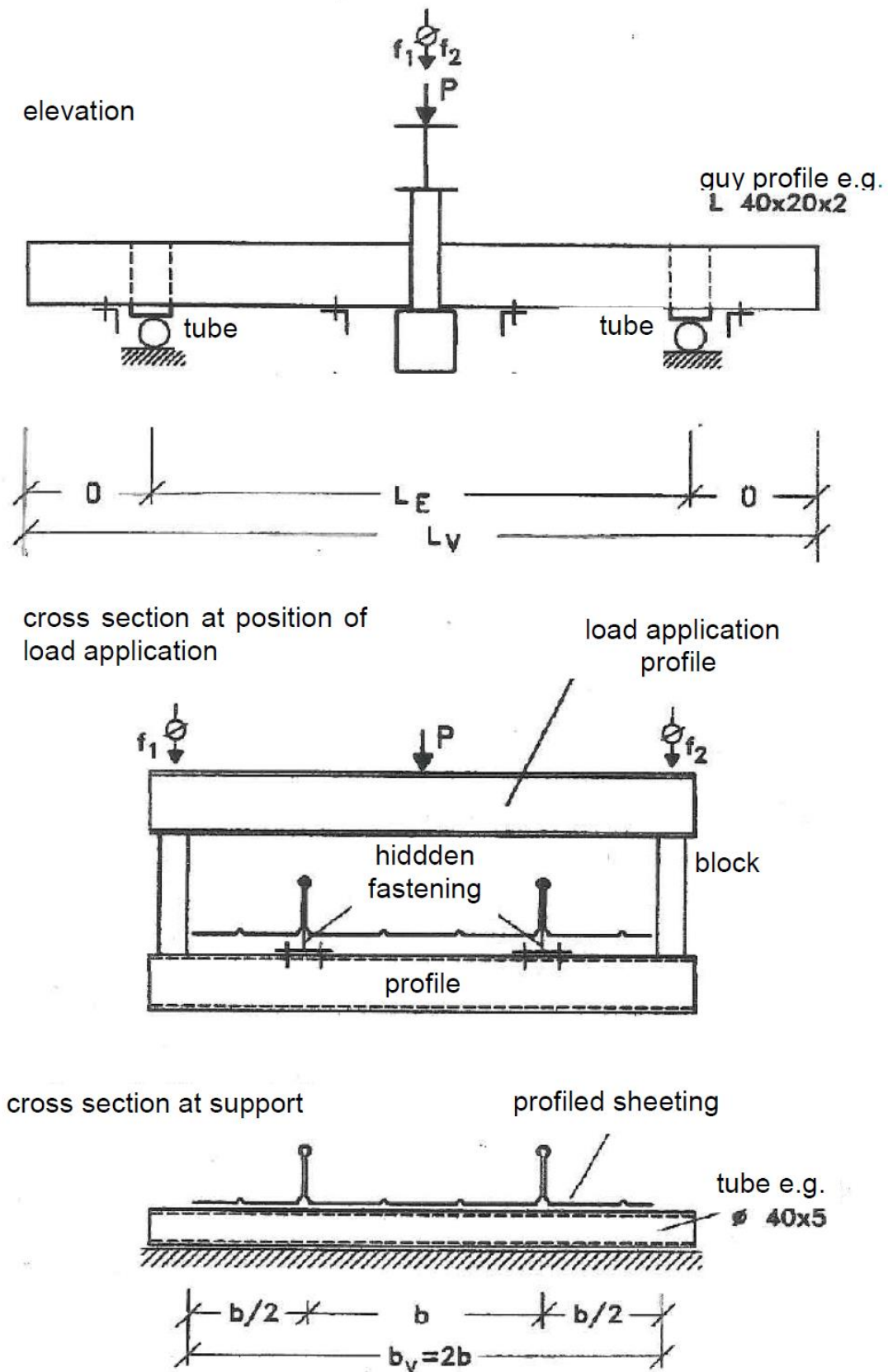

Figure 4: internal support test for uplift load

ANNEX D HIDDEN FASTENINGS – TEST SETUP

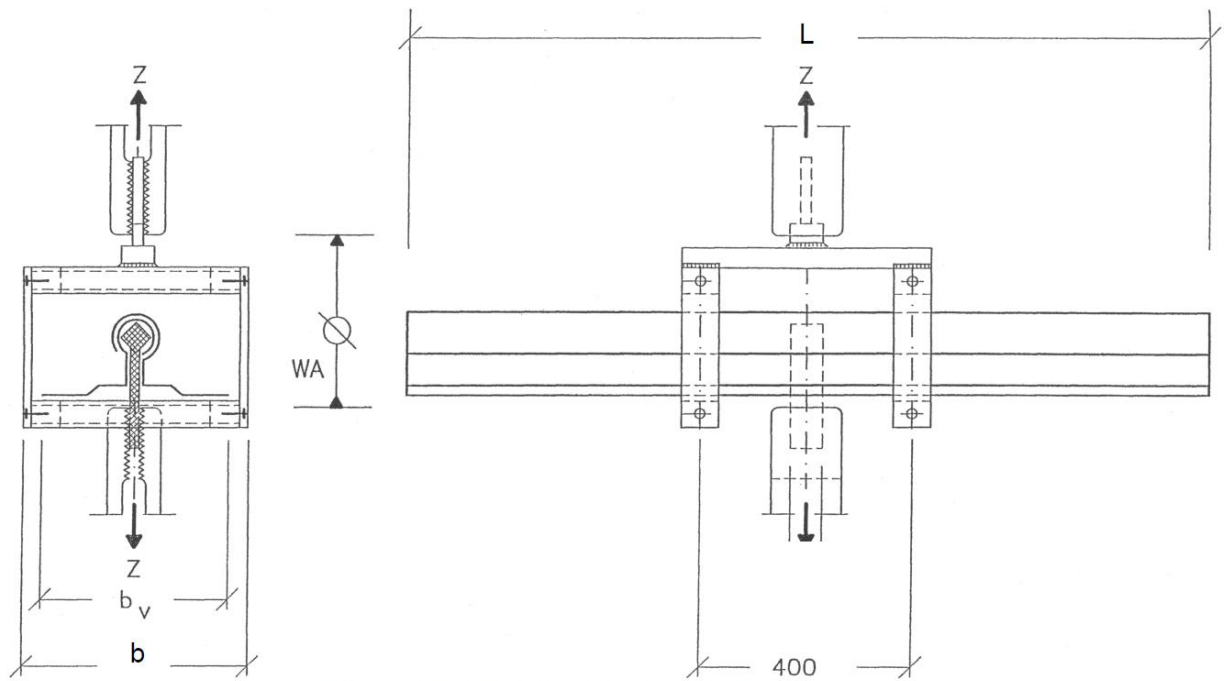
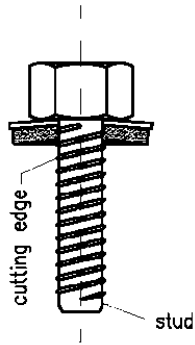

Figure 1: test setup for tensile tests

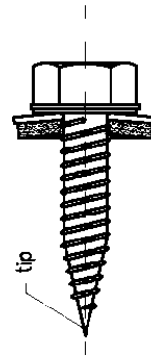

Figure 2: test setup for compression test

ANNEX E SAMPLES FOR FASTENING SCREWS AND CORRESPONDING CONNECTIONS



selftapping fastening screw with sealing washer



selftapping fastening screw with sealing washer

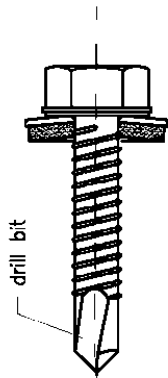

selfdrilling fastening screw with sealing washer

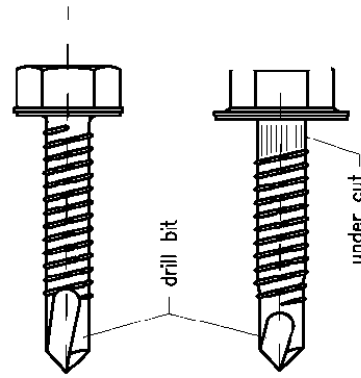

selfdrilling fastening screw with integrated washer

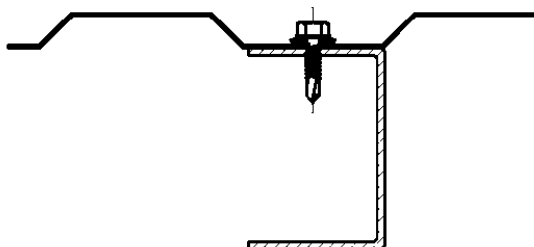



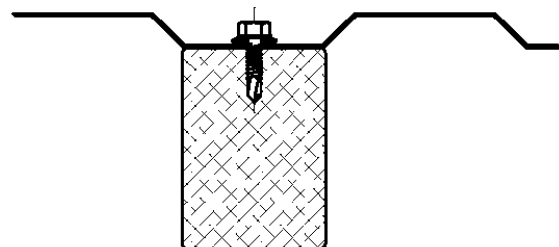

fastening of sheeting to a steel member



fastening of sheeting on timber substrate

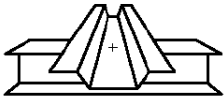
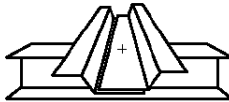
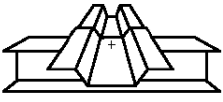

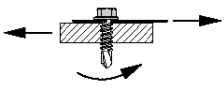
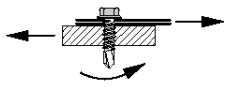

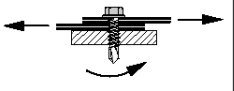
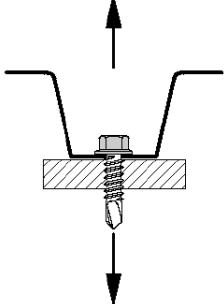
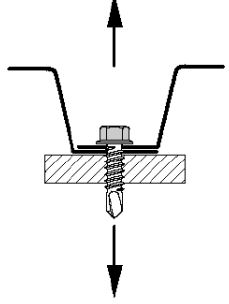
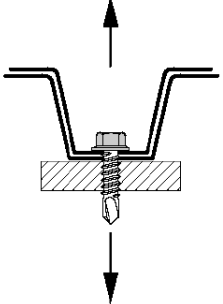
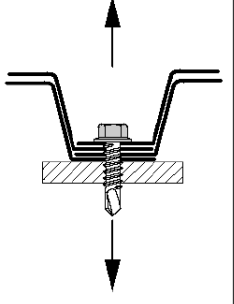
ANNEX F SAMPLES FOR FASTENING SCREWS AND CORRESPONDING CONNECTIONS

Types of connection and corresponding loading conditions

	Types of connection			
	Type a	Type b	Type c	Type d
				
Type of loading	Single connection	Side lap connection	End overlap connection	Side lap + end overlap connection
Lateral loading due to constraining forces due to temperature, in plane components of wind, dead loads, etc.				
Tension loading due to wind suction				

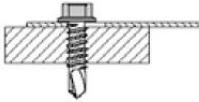
ANNEX G FASTENER: TYPES OF CONNECTION AND CORRESPONDING LOADING CONDITIONS

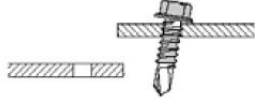
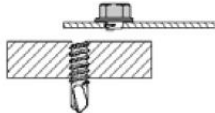
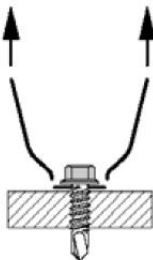
Possible failure modes of connections

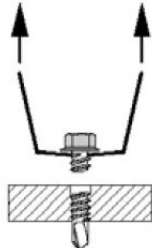
Type of loading	Failing component		
	sheeting	base material	cartridge fired pin
Lateral shear loading	 <p>Slotted hole</p>	 <p>Slotted hole</p>  <p>Rotation of fastener</p>  <p>Pull-out of fastener</p>	 <p>Shear failure</p>
Tensile loading	 <p>Pull-through with punching shear failure</p>  <p>Pull-through</p>	 <p>Pull-out</p>	 <p>Tension failure of fastener</p>

**ANNEX H FASTENER: TEST SETUP FOR PULL-THROUGH TESTS
TEST SETUP FOR PULL-OUT TESTS**

Pull-through specimen (with or without folded lip)

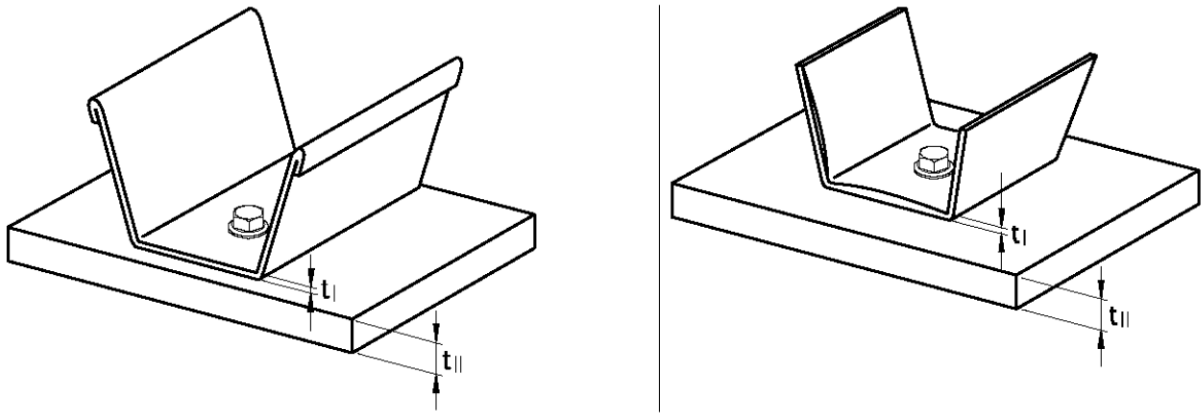

Pull-out test with pull-through specimen

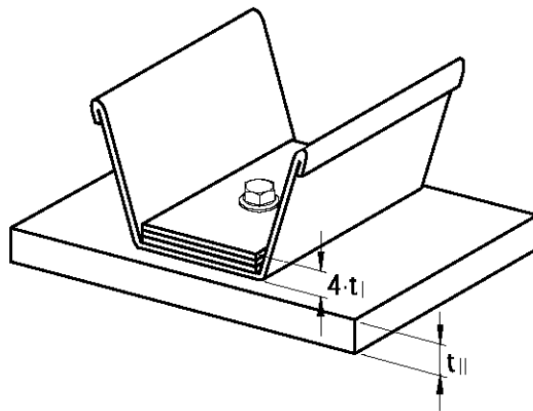

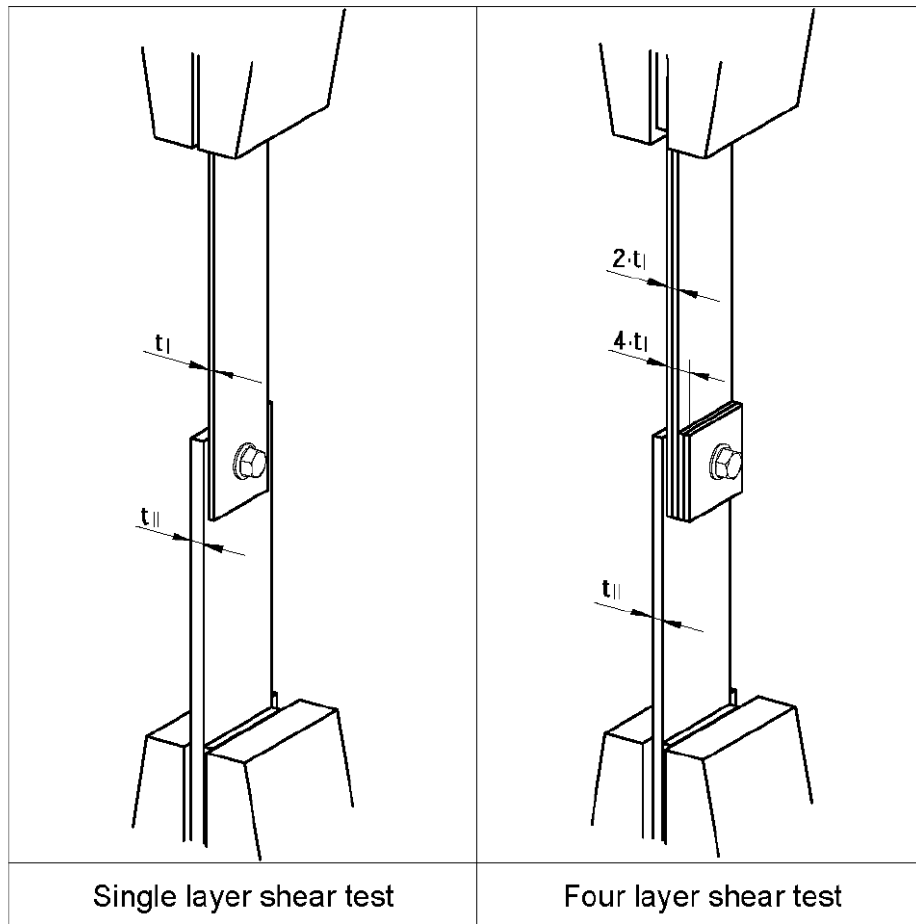
ANNEX I FASTENER: TEST SETUP FOR SHEAR TESTS**Shear test setup**

Remark: Clamping of the specimen in the test equipment has to be done in such a way, that the axis of the load is lying in the interface between the sheeting (t_I) and the base material (t_{II}).