



EUROPEAN ASSESSMENT DOCUMENT

EAD 330084-00-0601

January 2016

STEEL PLATE WITH CAST-IN ANCHORS

The reference title and language for this EAD is English. The applicable rules of copyright refer to the document elaborated in and published by EOTA.

This European Assessment Document (EAD) has been developed taking into account up-to-date technical and scientific knowledge at the time of issue and is published in accordance with the relevant provisions of Regulation (EU) No 305/2011 as a basis for the preparation and issuing of European Technical Assessments (ETA).

Contents

1	Scope of the EAD.....	4
1.1	Description of the construction product	4
1.2	Information on the intended use of the construction product	7
1.2.1	Intended use	7
1.2.3	Working life/ Durability.....	8
1.3	Specific terms used in this EAD	8
2	Essential characteristics and relevant assessment methods and criteria.....	9
2.1	Essential characteristics of the product	9
2.2	Methods and criteria for assessing the performance of the product in relation to essential characteristics of the product	10
2.2.1	General	11
2.2.2	Steel failure of anchors under tension load	11
2.2.3	Pull-out failure for cracked concrete under tension load	12
2.2.4	Concrete cone failure	12
2.2.5	Splitting failure due to loading	13
2.2.6	Steel failure for headed studs without lever arm under shear load	13
2.2.7	Pryout failure.....	13
2.2.8	Concrete edge failure	13
2.2.9	Arc stud welding (drawn arc stud welding, process 783) for headed studs	13
2.2.10	MAG Welding (process 135, 136 and 138) for anchor bolts with smooth shaft and anchor bolts of reinforcing steel	13
2.2.11	Characteristic displacements	14
2.2.12	Durability	14
2.2.13	Reaction to fire.....	15
3	ASSESSMENT AND VERIFICATION OF CONSTANCY OF PERFORMANCE to be applied..	16
3.1	System of assessment and verification of constancy of performance	16
3.2	Tasks of the manufacturer	16
3.3	Tasks of the notified body	17
4	Reference documents	18

1 SCOPE OF THE EAD

1.1 Description of the construction product

The construction product consists of one or several anchors (groups) welded to a steel plate. Depending on the welding procedure the anchors are welded to the steel plate either in the manufacturing plant or on the construction site (see "Welded joint"). The steel plate with welded-on anchors is embedded surface-flush in the concrete.

The details of the construction product are shown in Figure 1.1.

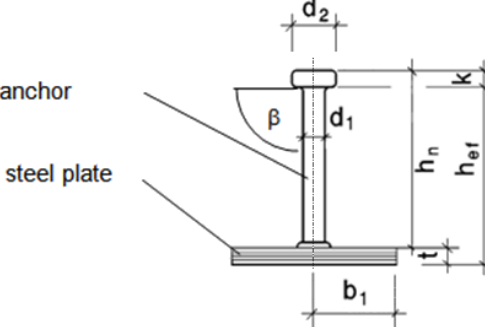
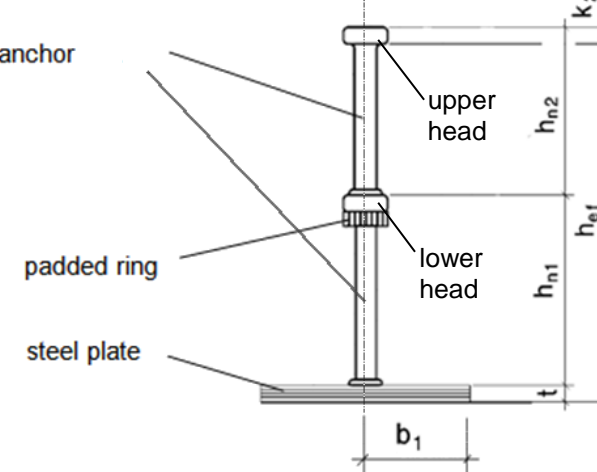
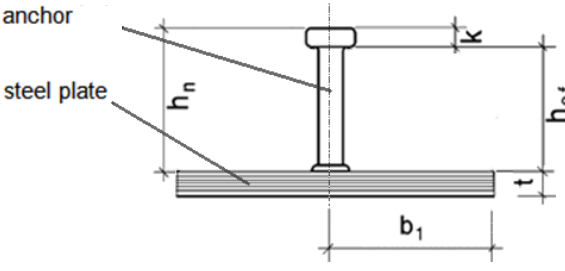
<p>1) Single anchor with small steel plate and small thickness</p> <p>In each direction shall be met: $b_1 \leq 0.5 h_n$ and $t < 0.2 h_n$</p>		$h_{ef} = h_n - k + t$
<p>2) Double anchor with small steel plate and small thickness</p> <p>In each direction shall be met: $b_1 \leq 0.5 (h_{n1} + h_{n2})$ and $t < 0.2 (h_{n1} + h_{n2})$</p>		$h_{ef} = h_{n1} + h_{n2} - k_2 + t$
<p>3) Single anchor with large steel plate and large thickness</p> <p>In any direction: $b_1 > 0.5 h_n$ or $t \geq 0.2 h_n$</p>		$h_{ef} = h_n - k$

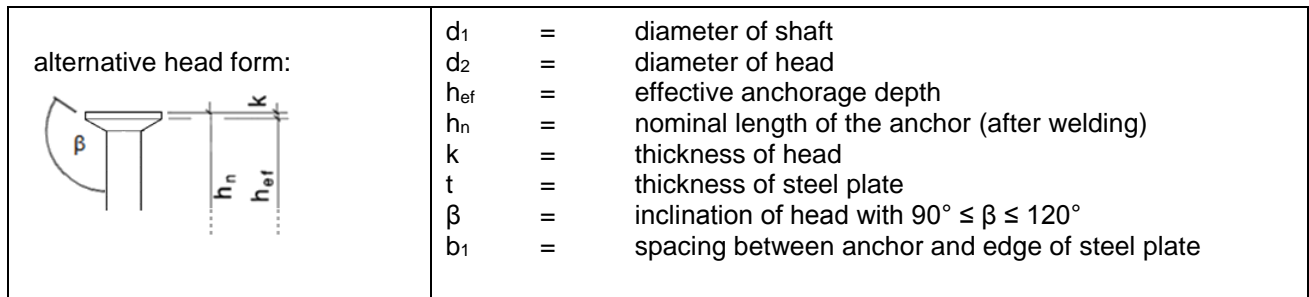

Figure 1.1 – Details of the construction product

Anchors

The anchors consist of steel or stainless steel. One of the ends of the anchor is provided with an anchor head, the other one is prepared for welding. The shaft diameter is 25 mm at maximum. The ratio between head diameter and shaft diameter is at least 1.6.

The following anchors may be used:

- a) Headed studs of steel or stainless steel for arc stud welding with the dimensions and the symbol "SD" according to Table 2 and 10 of EN ISO 13918:2008 [2]. It is also allowed to use two headed studs welded on top of each other by means of arc stud welding (see Fig. 1.1). For this purpose a padded ring shall be placed underneath the head of the first headed stud. This ring shall be secured in its position and shall durably allow a compression of ≥ 5 mm. The padded ring can be, for example, of technical felt or of cellular rubber. The external diameter of the padded ring shall exceed the head diameter and the internal diameter shall be less than shaft diameter. The padded ring is intended to prevent contact of the lower head with the concrete and a load transfer through the lower head.
- b) Anchor bolts with smooth shaft provided with an anchor head acc. Fig. 1.1 "alternative head form" made of steel according to EN 10025 [3] or suitable stainless steel according to EN 10088-1+3 [4].
- c) Anchors bolts of ribbed reinforcing steel B500B according to EN 1992-1-1, Annex C [5] provided with an anchor head acc. Fig. 1.1 "alternative head form".

The materials of the anchors are given in Table 1.1.

The anchorage depth shall be ≥ 50 mm.

Steel plate

The steel plate shall be made of steel according to EN 10025-2 [3] or suitable stainless steels according to EN 10088-1+3 [4].

The materials of the steel plate are given in Table 1.1.

In structures acted upon by tensile forces in the thickness direction of the steel plate, action shall be taken to ensure that transmission of force in the thickness direction is satisfactory in view of the risk of lamellar tearing in the steel plate.

Welded joint

Headed studs for arc stud welding according to [2] shall be welded to the steel plate by means of drawn arc stud welding with ceramic ferrules or shielding gas (process 783 referred to in EN ISO 4063 [10] in accordance with EN ISO 14555 [6]. Welding of the headed studs via arc stud welding may be performed in the manufacturing plant or on the construction site.

The anchor bolts with smooth shaft or of ribbed reinforcing steel shall be welded to the steel plate via the metal active gas welding (MAG welding with solid wire electrode - process 135 and MAG welding with flux cored electrode - process 136 and MAG welding with metal cored electrode - process 138) according to EN ISO 4063:2010 [10]. The anchor bolts shall be butt-welded to the steel plate with fillet welds. Alternatively the anchor bolt may be inserted in a hole in the steel plate and welded with fillet welds.

For welding of reinforcing steel EN ISO 17660:2006 + AC [9] applies.

The welding-on of the anchor bolts via MAG-welding may only be carried out in the manufacturing plant.

Table 1.1: Designation and materials

Part	Designation	Materials	Mechanical properties
1	Headed stud according to EN ISO13918:2008, geometry acc. Typ: SD	Steel S235J2+C450 acc. to EN 10025 with C ≤ 0.18% and Al ≥ 0.02%	$f_{uk} \geq 450 \text{ N/mm}^2$, $f_{yk} \geq 350 \text{ N/mm}^2$
		Stainless steel 1.4301, 1.4303, 1.4306, 1.4307 or 1.4401, 1.4404, 1.4571, 1.4432, 1.4436, 1.4439 acc. to EN 10088-1	$f_{uk} \geq 500\text{-}780 \text{ N/mm}^2$, $f_{yk} \geq 350 \text{ N/mm}^2$
	Anchor bolts with smooth shaft provided with an anchor head	Steel S235J2; S355J2 acc.to EN 10025	$f_{uk} \geq 450 \text{ N/mm}^2$, $f_{yk} \geq 350 \text{ N/mm}^2$
		Stainless steel 1.4301, 1.4303, 1.4306, 1.4307 or 1.4401, 1.4404, 1.4571, 1.4432, 1.4436, 1.4439 acc. to EN 10088-1	$f_{uk} \geq 450 \text{ N/mm}^2$, $f_{yk} \geq 350 \text{ N/mm}^2$
	Anchor bolts of ribbed reinforcing steel provided with an anchor head	Reinforcing steel B500B acc.to EN 1992-1-1, Annex C	$f_{uk} \geq 550 \text{ N/mm}^2$, $f_{yk} \geq 500 \text{ N/mm}^2$
2	Steel plate	Steel S235JR; S235JO; S235J2; S355JR; S355JO, S355J2, S355K2 acc.to EN 10025-2	acc.to EN 10025-2
		Stainless steel 1.4301, 1.4303, 1.4306, 1.4307 or 1.4401, 1.4404, 1.4571, 1.4432, 1.4436 or 1.4439 acc.to EN 10088-1	acc.to EN 10088-1

Different versions of steel plate with welded-on anchors with respect to material, strength or dimensions are marked such that the relevant product characteristic is allocated to the corresponding anchor type.

The product is not covered by a harmonised European standard (hEN).

Concerning product packaging, transport, storage, maintenance, replacement and repair it is the responsibility of the manufacturer to undertake the appropriate measures and to advise his clients on the transport, storage, maintenance, replacement and repair of the product as he considers necessary.

It is assumed that the product will be installed according to the manufacturer's instructions or (in absence of such instructions) according to the usual practice of the building professionals.

Relevant manufacturer's stipulations having influence on the performance of the product covered by this European Assessment Document shall be considered for the determination of the performance and detailed in the ETA.

1.2 Information on the intended use of the construction product

1.2.1 Intended use

The steel plate with welded-on anchors shall be anchored in reinforced normal weight concrete of a minimum strength class of C20/25 according to EN 206-1 [12]. They may be used in cracked and in non-cracked concrete subject to static or quasi static actions.

The construction product can be acted upon by tension load, shear load or a combination of tension and shear loads. The minimum thickness of the concrete member for the anchorage of the steel plate with welded-on anchors results from the sum of the anchorage depth of the anchors, the height of the anchor's head and the required concrete cover.

The steel plate with welded-on anchors is surface-flush embedded in the concrete. Further steel components may be welded to the steel plate. When welding the steel members to the steel plate the occurring thermal stress shall be considered. The installation conditions are shown in Figure 1.2.

Depending on the materials used for the steel plate with welded-on anchors it may be used in structures subjected to the following categories (see for details section 2.2.11.2):

- dry internal conditions,
- external atmospheric exposure or exposure in permanently damp internal conditions.

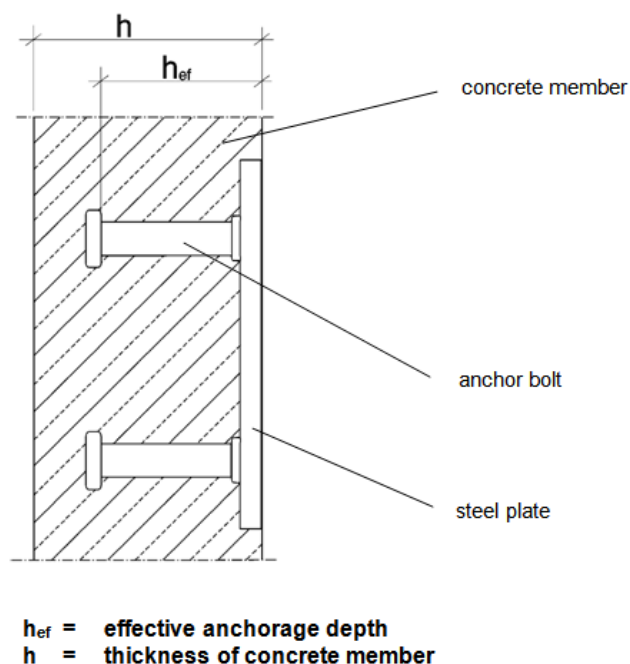

Figure 1.2 –Example for installed product

The steel plate with welded-on anchors is anchored in concrete by mechanical interlock between the anchor and the concrete member.

The steel plate with welded-on anchors is intended to be used for anchorages which are designed according to the design method given in CEN/TS 1992-4:2009 "Design of fastenings for use in concrete", part 1 and 2 [14].

It is assumed that the installation of the product will be undertaken in line with the manufacturer's product installation instructions.

This EAD takes account of a reasonable degree of imperfection in relation to installation and thus control methods on site after installation will in general not be necessary. This assumes, however, that gross errors on site will be avoided by use of instructions and correct training of the installers and supervision on site.

1.2.3 Working life/ Durability

The assessment methods included or referred to in this EAD have been written based on the manufacturer's request to take into account a working life of the fastener for the intended use of 50 years when installed in the works (provided that the steel plate with welded-on anchors is subject to appropriate installation (see 1.1)) These provisions are based upon the current state of the art and the available knowledge and experience.

When assessing the product the intended use as foreseen by the manufacturer shall be taken into account. The real working life may be, in normal use conditions, considerably longer without major degradation affecting the basic requirements for works¹.

The indications given as to the working life of the construction product cannot be interpreted as a guarantee neither given by the product manufacturer or his representative nor by EOTA when drafting this EAD nor by the Technical Assessment Body issuing an ETA based on this EAD, but are regarded only as a means for expressing the expected economically reasonable working life of the product.

1.3 Specific terms used in this EAD

The specific terms used in this EAD are given in ETAG 001 [1].

¹ The real working life of a product incorporated in a specific works depends on the environmental conditions to which that works is subject, as well as on the particular conditions of the design, execution, use and maintenance of that works. Therefore, it cannot be excluded that in certain cases the real working life of the product may also be shorter than referred to above.

2 ESSENTIAL CHARACTERISTICS AND RELEVANT ASSESSMENT METHODS AND CRITERIA

2.1 Essential characteristics of the product

Table 2.1 shows how the performance of the anchorage is established in relation to the essential characteristics.

Table 2.1 Essential characteristics of the product and methods and criteria for assessing the performance of the product in relation to those essential characteristics

No	Essential characteristic	Assessment method	Type of expression of product performance
Basic Works Requirement 1: Mechanical resistance and stability			
1	Characteristic resistance under static and quasi-static loading	2.2.2, 2.2.9, 2.2.10	description ($N_{Rk,s}$ [kN])
		2.2.3	description ($N_{Rk,p}$ [kN])
		2.2.4	description (h_{ef} , $S_{cr,N}$, $C_{cr,N}$ [mm], k_{cr} , k_{ucr} [-])
		2.2.6	description ($V_{Rk,s}$ [kN])
		2.2.7	description (k_5 [-])
		2.2.8	description ($V_{Rk,c}$ [kN])
2	Displacements	2.2.11	description (δ_{N0} , $\delta_{N\infty}$, δ_{V0} , $\delta_{NV\infty}$ [mm])
3	Durability	2.2.12	description (steel) or
			description (stainless steel)
Basic Works Requirement 2: Safety in case of fire			
4	Reaction to fire	2.2.13	Class A1

2.2 Methods and criteria for assessing the performance of the product in relation to essential characteristics of the product

The anchorage shall be characterised according to Table 2.2.

Table 2.2: Material and dimensions of the product

No	Product property	Assessment method
1	Dimensions acc. Fig.1.1	Measuring or optical
2	Tensile Load (N_p) or tensile strength (f_{uk})	Similar to EN ISO 6892
3	Yield strength (f_{yk} or $N_{p0.2}$)	Similar to EN ISO 6892
4	Fracture elongation A_5	Similar to EN ISO 6892

The essential characteristics are only valid if the following conditions are reflected in the ETA and the planning and fulfilled on jobsite:

- (1) The following installation values have to be observed in the planning
 - minimum member thickness,
 - minimum edge distance of anchors,
 - minimum spacing of the anchors,
 - minimum effective anchorage depth.
- (2) Steel plate with welded-on anchors to be installed ensuring not less than the specified minimum effective anchorage depth. The edge distance and spacing of anchor have to be kept to the specified values.
- (5) Use of the anchorage only as supplied by the manufacturer without exchanging the components.
- (6) The steel plates with welded-on anchors are fixed on the formwork such that no movement of the steel plates with welded-on anchors will occur during the time of laying the reinforcement and of placing and compacting the concrete.
- (7) The concrete under the head of the anchors are properly compacted.
- (8) Welding of an attached element to the steel plate with welded-on anchors may only be performed by companies meeting the corresponding quality requirements for welding according to EN ISO 3834 [15] or by an equivalent welding qualification e.g. EN 1090-2 for the welding process in use.

The required tests are shown in Table 2.3.

Table 2.3: Required tests

N°	Test	h _{ef} [mm]	Concrete strength	minimum number of tests	Anchor diameter [mm]		
					(≤ Ø 13) small	(>Ø 13 < Ø 22) medium	(≥Ø 22) large
1	Steel failure centric tension	-	-	≥ 3	X	X	X
2	Welded joints	Testing according to Table 1 of EN ISO 14555 [6] drawn arc stud welding, at minimum and maximum bolt diameter					
2.1	Arc stud welding (process 783) for headed studs						
2.2	MAG welding (135/ 136/ 138) for anchor bolts with smooth shaft	Tensile test	≥ 3	X	X	X	
		Impact bending test ≥ 60°	≥ 3	X	X	X	
2.3	MAG welding (135/ 136/ 138) for anchor bolts of reinforcing steel	Tensile test	≥ 3	X	X	X	
		Impact bending test ≥ 60°	≥ 3	X	X	X	

2.2.1 General

Tests

For the individual tests the maximum loads shall be determined by indicating the failure mode. The load/displacement curves shall be recorded.

Requirements for the load-displacement behaviour

In the load range concerned the load displacement curves shall have a steadily rising development. The requirements specified in section 6.1.1.1 of Part 1 of ETAG 001 [1] apply.

2.2.2 Steel failure of anchors under tension load

The characteristic resistances are determined with reference to CEN/TS 1992-4:2009 [14].

The test is carried out on anchors not cast into concrete. The test shall be carried out per anchor with any type of material.

When evaluating the test results the current dimensions and current steel strengths shall be taken into account.

The characteristic resistance $N_{Rk,s}$ shall be determined for the shaft diameter according to (1) and shall be confirmed by means of the test series 1 of Table 2.3.

$$N_{Rk,s} = A_s \times f_{uk} \quad [N] \quad (1)$$

A_s = stress diameter of the anchor [mm²]

f_{uk} = characteristic tensile strength of the anchor [N/mm²]

2.2.3 Pull-out failure for cracked concrete under tension load

The characteristic resistance $N_{Rk,p}$ for pull-out is:

$$N_{Rk,p} = \rho_{uk} \bullet A_k \text{ [N]} \quad (2)$$

$$\begin{aligned} \rho_{uk} &= \text{characteristic compressive stress of the concrete under the head of the bolt} \\ &= 6.0 \times f_{ck} \text{ [N/mm}^2\text{]} \end{aligned} \quad (3)$$

f_{ck} = characteristic concrete compressive strength [N/mm²]

A_k = plain standing of the anchor [mm²]

$$= \frac{\pi}{4} (d_2^2 - d_1^2) \quad (4)$$

d_2 = head diameter [mm]

d_1 = shaft diameter of the anchor [mm]

2.2.4 Concrete cone failure

For the verification of concrete cone failure CEN/TS 1992-4, part 2 [14] applies with the following values:

Effective anchorage depth

(See figure 1.1)

a) **Single anchor** with small steel plate and small thickness

In each direction shall be met: $b_1 \leq 0.5 h_n$ and $t < 0.2 h_n$

$$h_{ef} = h_n - k + t \text{ [mm]} \quad (5)$$

b) **Double anchor** with small steel plate and small thickness

In each direction shall be met: $b_1 \leq 0.5 (h_{n1} + h_{n2})$ and $t < 0.2 (h_{n1} + h_{n2})$

$$h_{ef} = h_{n1} + h_{n2} - k_2 + t \text{ [mm]} \quad (6)$$

c) **Single anchor** with large steel plate and/ or large thickness or with small steel plate and large thickness

In any direction at least one is met: $b_1 > 0.5 h_n$ or $t \geq 0.2 h_n$

$$h_{ef} = h_n - k \quad (7)$$

Factor to take into account the influence of load transfer mechanisms:

$$k_{cr} = 8.5$$

$$k_{ucr} = 11.9$$

Characteristic spacing:

$$s_{cr,N} = 3h_{ef}$$

Characteristic edge distance:

$$c_{Cr,N} = 1.5h_{ef}$$

2.2.5 Splitting failure due to loading

It is generally assumed that the concrete is cracked and that the occurring splitting forces are resisted by the reinforcement acc. CEN/TS 1992-4-2, section 6.2.6.2 b).

2.2.6 Steel failure for headed studs without lever arm under shear load

The characteristic resistance $V_{Rk,s}$ shall be determined for the shaft cross-section of the anchor with reference to CEN/TS 1992-4:2009, part 2 [14].

$$V_{Rk,s} = \alpha \cdot A_s \cdot f_{uk} \quad (8)$$

α = 0.6 (In [17] it is recommended, for anchor with welded steel plate, to use the α -value with 0.6.)

A_s = stress cross-section of anchor [mm²]

f_{uk} = characteristic tensile strength of anchor [N/mm²]

2.2.7 Pryout failure

k_5 = 1.0 for anchors with $h_{ef} < 60$ mm [-]
 2.0 for anchors with $h_{ef} \geq 60$ mm [-]

2.2.8 Concrete edge failure

The characteristic resistance $V_{Rk,c}$ of fastening for anchors at the member edge under shear loading is determined according to CEN/TS 1992-4:2009, part 2 [14].

2.2.9 Arc stud welding (drawn arc stud welding, process 783) for headed studs

Testing according to Table 1 of EN ISO 14555 [6] drawn arc stud welding, at minimum and maximum bolt diameter.

The assessment of the welded joints for the headed studs according to [2] shall be performed in accordance with Table 1 of EN ISO 14555 [6] at the minimum and maximum diameter.

The same provision applies to the welding procedure qualification.

2.2.10 MAG Welding (process 135, 136 and 138) for anchor bolts with smooth shaft and anchor bolts of reinforcing steel

The verification of the fusion-welded joints when using anchor bolts with smooth shaft is performed via tensile tests and impact bending tests at 60° with 3 samples each of the anchor bolt diameter.

For the welding procedure qualification EN ISO 15614-1 + A1 + A2 [7] applies.

The verification of the welded joints when using a

anchor bolts of ribbed reinforcing steel is performed according to EN ISO 17660 + AC [9]. Three samples per anchor bolt size shall be tested by tensile tests and three samples per anchor bolt size by impact bending tests at 60°.

The weld seams according to quality level C according to EN ISO 5817:2014 [8].

The welding of the anchor bolt of reinforcing steel is according to EN ISO 17660:2006+ AC [9].

2.2.11 Characteristic displacements

The characteristic displacements for short-term (δ_{N0} , δ_{V0}) and quasi-permanent loading ($\delta_{N\infty}$, $\delta_{V\infty}$) are specified for the tension load N and shear load V in accordance with following equation:

$$N = N_{Rk} / (\gamma_F \cdot \gamma_M) \quad (9)$$

with: N_{Rk} = characteristic resistance

γ_F = partial safety factor for actions = 1,4

γ_M = partial safety factor for material according CEN/TS 1992-4:2009 [14]

$$V = V_{Rk} / (\gamma_F \cdot \gamma_M) \quad (10)$$

with: V_{Rk} = characteristic resistance

γ_F = partial safety factor for actions = 1,4

γ_M = partial safety factor for material according CEN/TS 1992-4:2009 [14]

The displacements δ_{N0} and δ_{V0} under short-term loading may be evaluated from tests of single anchors in concrete. The displacements δ_{N0} under short-term loading may also be calculated according to [19] if the product is according to the assumptions of [19]. The displacements δ_{V0} under short-term loading for headed studs may also be used according to Table 2.4. The values which are derived by tests should correspond to the mean value of these test series. The displacements (in mm) should be rounded up to zero or five on the first place after the decimal point.

Table 2.4: Displacements δ_{V0} under short-term loading for headed studs according to current experiences

Diameter of shaft of headed stud [mm]	10	13	16	19	22	25
Displacements to 1.5 mm under following shear loads	15	20	30	45	60	75

The displacements $\delta_{N\infty}$ under long-term tension loading are assumed to be approximately equal to 2,0-times the value δ_{N0} . The displacements $\delta_{V\infty}$ under long-term shear loading are assumed to be approximately equal to 1,5-times the value δ_{V0} . Under shear loading, the displacements might increase due to a gap between fixture and anchor channel. The influence of this gap is taken into account in design.

2.2.12 Durability

No special tests are required, if the conditions given in section 2.2.10.2 are complied with.

Supporting evidence that corrosion will not occur is not required if the steel parts of the steel plate with anchors are protected against corrosion, as set out below:

- (1) steel plate with anchors intended for use in structures subject to dry, internal conditions:
No special corrosion protection is necessary for steel parts as coatings provided for preventing corrosion during storage prior to use and for ensuring proper functioning zinc coating with a minimum thickness of 5 microns) is considered sufficient.

- (2) steel plate with anchors for use in structures subject to external atmospheric exposure (including industrial and marine environments), or exposure in permanently damp internal condition, if no particular aggressive conditions such as permanent or alternate immersion in seawater or the splash zone of seawater, chloride atmosphere of indoor swimming pools or atmosphere with extreme chemical pollution (e.g. in desulfurization plants or road tunnels, where de-icing materials are used) exists:

Steel plates are made of stainless steel material 1.4401, 1.4404, 1.4571, 1.4432, 1.4436 or 1.4439 according to EN 10088-4 and 5 [4] and anchors made of 1.4301, 1.4303, 1.4306 or 1.4307 according to EN 10088-4 and 5 [4] can be used. Whereas the spacing between anchors and the edge of the steel plate shall not be less than 50 mm, else the anchor shall be made of 1.4401, 1.4404, 1.4571, 1.4432, 1.4436 or 1.4439 according to EN 10088-4 and 5 [4].

2.2.13 Reaction to fire

The steel plate with anchors is considered to satisfy the requirements for performance class A1 of the characteristic reaction to fire, in accordance with the provisions of Commission Decision 1996/603/EC (as amended) on the basis of its listing in that decision.

3 ASSESSMENT AND VERIFICATION OF CONSTANCY OF PERFORMANCE TO BE APPLIED

3.1 System of assessment and verification of constancy of performance

For the products covered by this EAD the applicable European legal act is: Decision 1996/582/EC.

The system is: 1.

3.2 Tasks of the manufacturer

The cornerstones of the actions to be undertaken by the manufacturer of the anchorage in the procedure of assessment and verification of constancy of performance are laid down in Table 3.1.

Table 3.1 is an example only; the control plan depends on the individual manufacturing process and has to be established between notified body and manufacturer for each product.

Table 3.1 Control plan for the manufacturer; cornerstones

No	Subject/type of control	Test or control method	Criteria, if any	Minimum number of samples	Minimum frequency of control
Factory production control (FPC) [including testing of samples taken at the factory in accordance with a prescribed test plan]*					
Raw material					
1	Dimensions and material properties of raw material	Inspection certificate 3.1 according to EN 10204:2004	Control plan	1 ¹⁾	Each manufacturing batch
Tests after production steps					
2	Determination of the ultimate load of anchors by centric tension test	Section 2.2.2	Control plan	3 ¹⁾	Each manufacturing batch resp. per 10.000 anchors resp. once per three production weeks
3	Determination of geometry of anchorage	Gauge	Control plan	3 ¹⁾	Each manufacturing batch resp. per 10.000 anchorages resp. once per production week

¹⁾ for each size

3.3 Tasks of the notified body

The cornerstones of the actions to be undertaken by the notified body in the procedure of assessment and verification of constancy of performance for the anchor are laid down in Table 3.2.

Table 3.2 Control plan for the notified body; cornerstones

No	Subject/type of control	Test or control method	Criteria, if any	Minimum number of samples	Minimum frequency of control
Initial inspection of the manufacturing plant and of factory production control					
1	Ascertain that the factory production control with the staff and equipment are suitable to ensure a continuous and orderly manufacturing of the anchorage.	-	Laid down in control plan	-	-
Continuous surveillance, assessment and evaluation of factory production control					
2	Verifying that the system of factory production control and the specified automated manufacturing process are maintained taking account of the control plan.	-	Laid down in control plan	-	-

4 REFERENCE DOCUMENTS

- [1] ETAG 001 *Guideline for European technical approval for metal anchors for use in concrete, June 1997*
- [2] EN ISO 13918:2008 *Welding – Studs and ceramic ferrules for arc stud welding*
- [3] EN 10025 *Hot rolled products of non-alloy structural steels*
- [4] EN 10088-1+3 *Stainless steels; Part 1: List of stainless steels; Part 3: technical delivery conditions*
- [5] EN 1992-1-1, Annex C *Eurocode 2: Design of concrete structures- Part 1-1: General rules and rules for buildings, Annex C: Properties of reinforcement suitable for use with this Eurocode*
- [6] EN ISO 14555 *Welding – Arc stud welding of metallic materials*
- [7] EN ISO 15614-1
+ A1
+ A2 *Specification and qualification of welding procedures for metallic materials - Welding procedure test - Part 1: Arc and gas welding of steels and arc welding of nickel and nickel alloys*
- [8] EN ISO 5817 *Welding - Fusion-welded joints in steel, nickel, titanium and their alloys (beam welding excluded) - Quality levels for imperfections*
- [9] EN ISO 17660
+ AC *Welding of reinforcing steel*
- [10] EN ISO 4063:2010 *Welding and allied processes - Nomenclature of processes and reference numbers*
- [11] EN 1993-1-1 *Eurocode 3: Design of steel structures, Part 1-1: General rules and rules for buildings (includes Corrigendum AC:2009)*
- [12] EN 206-1 *Concrete, Part 1: Specification, performance, production and conformity*
- [13] EN 1992-1-1
+ AC *Eurocode 2: Design of concrete structures, Part 1-1: General rules and rules for buildings*
- [14] CEN/TS 1992-4:2009 *Design of fastenings for use in concrete*
- [15] EN ISO 3834 *Quality requirements for fusion welding of metallic materials*
- [16] EN 10204:2004 *Metallic products - Types of inspection documents*
- [17] Rolf, E., Mollée, R., Silva, J. F.: *Anchorage in Concrete Construction. Ernst & Sohn, Berlin, 2006.*
- [18] EN 1090-2
+A1 *Execution of steel structures and aluminium structures – Part 2: Technical requirements for steel structures*
- [19] Furche, J.: *Zum Trag- und Verschiebungsverhalten von Kopfbolzen bei zentrischem Zug". Doctor's thesis, University of Stuttgart, 1994.*