

EUROPEAN ASSESSMENT DOCUMENT

EAD 350134-00-1104

October 2014

**Fire proof water trap
with intumescent fire seal
(combined with a stainless steel floor
gully penetration)**

The reference title and language for this EAD is English. The applicable rules of copyright refer to the document elaborated in and published by EOTA.

This European Assessment Document (EAD) has been developed taking into account up-to-date technical and scientific knowledge at the time of issue and is published in accordance with the relevant provisions of Regulation (EU) No 305/2011 as a basis for the preparation and issuing of European Technical Assessments (ETA).

Contents

1	Scope of the EAD.....	4
1.1	Description of the construction product	4
1.2	Information on the intended use(s) of the construction product	4
1.2.1	Intended use(s)	4
1.2.2	Working life/Durability.....	4
2	Essential characteristics and relevant assessment methods and criteria.....	5
2.1	Essential characteristics of the product	5
2.2	Methods and criteria for assessing the performance of the product in relation to essential characteristics of the product	6
2.2.1	Reaction to fire.....	6
2.2.2	Resistance to fire.....	6
2.2.3	Content, emission and/or release of dangerous substances	6
2.2.4	Watertightness.....	6
2.2.5	Air tightness	6
2.2.6	Effectiveness of floor gully	7
2.2.7	Mechanical strength.....	7
2.2.8	Thermal behaviour	7
2.2.9	Durability of the intumescent inlay.....	8
3	ASSESSMENT AND VERIFICATION OF CONSTANCY OF PERFORMANCE	8
3.1	System(s) of assessment and verification of constancy of performance to be applied	8
3.2	Tasks of the manufacturer	8
3.3	Tasks of the notified body	10
4	Reference documents	12
Annex A	Specification of the construction product	13
Annex B	Test setup for the fire resistance test according to EN 1366-3.....	14

1 SCOPE OF THE EAD

1.1 Description of the construction product

The fire proof water trap is to be installed in a stainless steel floor gully penetration. The water trap comes with an intumescent paste which will expand in case of fire and seal the penetration in the fire classified building element, ensuring that the fire resistance of the building element is maintained. The trap is delivered in different sizes for different gullies. See drawings in annex A.

The intumescent material is placed inside the floor gully and is not in contact with the watertight covering or with the water, see drawing in annex 1. The intumescent material is highlighted on the drawing.

The product is not covered by a harmonised European standard (hEN).

Concerning product packaging, transport, storage, maintenance, replacement and repair it is the responsibility of the manufacturer to undertake the appropriate measures and to advise his clients on the transport, storage, maintenance, replacement and repair of the product as he considers necessary.

It is assumed that the product will be installed according to the manufacturer's instructions or (in absence of such instructions) according to the usual practice of the building professionals.

Relevant manufacturer's stipulations having influence on the performance of the product covered by this European Assessment Document shall be considered for the determination of the performance and detailed in the ETA.

1.2 Information on the intended use(s) of the construction product

1.2.1 Intended use(s)

To be used together with specified drains in floors as a fire penetration seal in domestic, commercial and industrial buildings.

The corresponding use category in ETAG 026-2 is Z1.

1.2.2 Working life/Durability

The assessment methods included or referred to in this EAD have been written based on the manufacturer's request to take into account a working life of the fire proof water trap for the intended use of 10 years when installed in the works provided that the fire proof water trap is subject to appropriate installation (see 1.1)). These provisions are based upon the current state of the art and the available knowledge and experience.

When assessing the product the intended use as foreseen by the manufacturer shall be taken into account. The real working life may be, in normal use conditions, considerably longer without major degradation affecting the basic requirements for works¹.

The indications given as to the working life of the construction product cannot be interpreted as a guarantee neither given by the product manufacturer or his representative nor by EOTA when drafting this EAD nor by the Technical Assessment Body issuing an ETA based on this EAD, but are regarded only as a means for expressing the expected economically reasonable working life of the product.

¹ The real working life of a product incorporated in a specific works depends on the environmental conditions to which that works is subject, as well as on the particular conditions of the design, execution, use and maintenance of that works. Therefore, it cannot be excluded that in certain cases the real working life of the product may also be shorter than referred to above.

2 ESSENTIAL CHARACTERISTICS AND RELEVANT ASSESSMENT METHODS AND CRITERIA

2.1 Essential characteristics of the product

Table 1 shows how the performance of the fire proof water trap is established in relation to the essential characteristics.

Table 1. Essential characteristics of the product and methods and criteria for assessing the performance of the product in relation to those essential characteristics

Nr	Essential characteristic	Assessment method	Type of expression of product performance <i>(level, class, description)</i>
Basic Works Requirement 2: Safety in case of fire			
1	Reaction to fire	2.2.1	Class
2	Resistance to fire	2.2.2	Class
3	Durability of intumescent inlay	2.2.8	Description
Basic Works Requirement 3: Hygiene, health and the environment			
4	Watertightness	2.2.3	Level
5	Airtightness	2.2.4	Level
6	Effectiveness of floor gully	2.2.5	Level
Basic Works Requirement 4: Safety and accessibility in use			
7	Mechanical strength	2.2.6	Level
8	Thermal behaviour	2.2.7	Level

2.2 Methods and criteria for assessing the performance of the product in relation to essential characteristics of the product

Characterisation of products to be assessed shall be done in accordance with available specifications, notably material properties and dimensions.

2.2.1 Reaction to fire

The components of the fire proof water trap, i.e. the intumescent paste shall be tested, using the test method(s) relevant for the corresponding reaction to fire class, in order to be classified according to EN Commission Delegated Regulation (EU) 2016/364.

The metal parts are classified according to Commission Decision 1996/603/EC as amended.

The components are classified according to Commission Delegated Regulation (EU) 2016/364 and the class is stated in the ETA.

2.2.2 Resistance to fire

An assembly representative of a floor structure in which the fire proof water trap is intended to be installed shall be tested, using the test method relevant for the corresponding fire resistance class, in order to be classified according to EN 13501-2.

The fire test are carried out according to EN 1366-3:2009 using the test configuration according to Annex B.

Note: Due to the nature and use of the penetration seal in the floor gully, a blank penetration seal test can be omitted, since it by nature cannot be used without services.

The tested penetration seals incorporating the fire proof water trap are classified according to EN 13501-2. The classification are used for each test specimen. Other installation situations than that tested shall not be part of the assessment (see 1.2.2).

The pipe end configuration shall be given, using for outside the furnace "capped" when a water filled trap was used in the test and "uncapped", when the trap was installed without water in the fire test.

2.2.3 Watertightness

The following tests are carried out in order to assess the water tightness of the floor gully:

The water tightness is tested in accordance with EN 1253-2 (2004), Gullies for buildings - Part 2: Test methods, clause 10.2.

The tightness for sheet floor coverings and/or membrane is tested in accordance with EN 1253-2 (2004), Gullies for buildings - Part 2: Test methods, clause 10.3

The performance of the floor gully is declared in accordance with the requirements in EN 1253-1 (2003), Gullies for buildings - Part 1: Requirements, clause 8.9.2 and, possibly, 8.9.6

The performance of the floor gully is declared in accordance with the requirements in EN 1253-1 (2003), Gullies for buildings - Part 1: Requirements, clause 8.9.3 and 8.9.4

2.2.4 Air tightness

The odour tightness is tested in accordance with EN 1253-2 (2004), Gullies for buildings - Part 2: Test methods, clause 10.1.

The performance of the floor gully is declared in accordance with the requirements in EN 1253-1 (2003), Gullies for buildings - Part 1: Requirements, clause 8.9.1

2.2.5 Effectiveness of floor gully

The following tests are carried out in order to assess the effectiveness of the floor gully:

The access for cleaning is tested in accordance with EN 1253-2 (2004), Gullies for buildings - Part 2: Test methods, clause 7.1.

The flow rate for water through the grating is tested in accordance with EN 1253-2 (2004), Gullies for buildings - Part 2: Test methods, clause 11.1.

The flow rate for water through the grating and side inlets are tested in accordance with EN 1253-2 (2004), Gullies for buildings - Part 2: Test methods, clause 11.2.

The self-cleaning is tested in accordance with EN 1253-2:2003, Gullies for buildings - Part 2: Test methods, clause 7.2.

The prevention for plugging is tested in accordance with EN 1253-2:2003, Gullies for buildings - Part 2: Test methods, clause 7.3.

The performance of the floor gully is declared in accordance with the requirements in EN 1253-1 (2003), Gullies for buildings - Part 1: Requirements, clause 8.6.1

The performance of the floor gully is declared in accordance with requirements in EN 1253-1 (2003), Gullies for buildings - Part 1: Requirements, clause 8.11.1

The performance of the floor gully is declared in accordance with the requirements in EN 1253-1 (2003), Gullies for buildings - Part 1: Requirements, clause 8.11.2

The performance of the floor gully is declared in accordance with the requirements in EN 1253-1 (2003), Gullies for buildings - Part 1: Requirements, clause 8.6.2

The performance of the floor gully is declared in accordance with the requirements in EN 1253-1 (2003), Gullies for buildings - Part 1: Requirements, clause 8.6.3.

2.2.6 Mechanical strength

The sequence of tests for the mechanical strength is in accordance with EN 1253-2 (2004), Annex B.

The loading strength is tested in accordance with EN 1253-2 (2004), Gullies for buildings - Part 2: Test methods, clause 4.

The mechanical strength for extension connection is tested in accordance with EN 1253-2 (2004), Gullies for buildings - Part 2: Test methods, clause 10.4.1.

The mechanical strength for clamping ring is tested in accordance with EN 1253-2 (2004), Gullies for buildings - Part 2: Test methods, clause 10.4.2.

The loading strength class of the gully as is declared in the ETA

The performance of the floor gully is declared in accordance with the requirements in EN 1253-1 (2003), Gullies for buildings - Part 1: Requirements, clause 8.10.1

The performance of the floor gully is declared in accordance with the requirements in EN 1253-1 (2003), Gullies for buildings - Part 1: Requirements, clause 8.10.2

2.2.7 Thermal behaviour

The test for temperature cycling is carried out in accordance with EN 1253-2 (2004), Gullies for buildings - Part 2: Test methods, clause 9.1.

The performance of the floor gully is declared in accordance with the requirements in EN 1253-1 (2003), Gullies for buildings - Part 1: Requirements, clause 8.8.1 and 8.8.2

2.2.8 Durability of the intumescent inlay

The intumescent inlay is subject to long term test and/or long term test with high temperature according to EOTA TR 024:2009.

The performance of the floor gully is declared in accordance with the requirements related to environmental condition Z₁.

3 ASSESSMENT AND VERIFICATION OF CONSTANCY OF PERFORMANCE

3.1 System(s) of assessment and verification of constancy of performance to be applied

For the products covered by this EAD the applicable European legal act is: Decision 1999/454/EC

The system is: 1

3.2 Tasks of the manufacturer

The cornerstones of the actions to be undertaken by the manufacturer of the product in the procedure of assessment and verification of constancy of performance are laid down in Table 2.

Table 2 Control plan for the manufacturer; corner stones

No	Subject/type of control (product, raw/constituent material, component - indicating characteristic concerned)	Test or control method (refer to 2.2 or 3.4)	Minimum frequency of control
Factory production control (FPC) [including testing of samples taken at the factory in accordance with a prescribed test plan]*			
1	Appearance (trap)	EN 1253-3 table 1	EN 1253-3 table 1
2	Dimensions (trap)	EN 1253-3 table 1	EN 1253-3 table 1
3	Materials (trap)	EN 1253-3 table 1	EN 1253-3 table 1
4	Skirt membrane affixed to the gully	EN 1253-3 table 1	EN 1253-3 table 1
5	Classification by loading strength (trap and gully)	EN 1253-3 table 1	EN 1253-3 table 1
6	Reaction to fire (class E) (all components)	EN 11925-2	once per week, or ¹⁾
	Reaction to fire (class B,C or D) (all components)	EN 13823 and EN 11925-2	once per month once per week, or ¹⁾
	Reaction to fire (class A2) ³⁾ (all components)	EN ISO 1182 or EN ISO 1716 and EN 13823	once per two years, and indirect testing ²⁾
	Reaction to fire (class A1) (all components)	EN ISO 1182 and EN ISO 1716 (and EN 13823)	once per two years, and indirect testing ²⁾
7	Raw material/constituents (all components)	Check conformity with the ordered quality	Every lot delivered
8	Intumescent paste	density	3 samples every production lot
9	Loss of mass at a certain temperature / ash content of intumescent paste	Percentage of mass loss according to EN ISO 3451-1	3 samples every production lot
10	Ability of a sample to create foam at a certain temperature of intumescent paste	Expansion ratio according to EOTA TR 024 clause 3.1.11	6 samples every production lot
11	Development of expansion pressure ²⁾ during foaming of intumescent paste	Expansion pressure according to EOTA TR 024 clause 3.1.12	10 samples every production lot
12	Watertight housing for intumescent paste	dimensions	3 samples every production lot

1) once per two years and indirect testing in accordance to the manufactures methods once per day, whereat Indirect testing is only possible in the case of products falling within the system 1 for attestation of conformity of reaction to fire, or by having a notified body verifying the correlation to the direct testing

2) once per day loss ignition and once per four hour weight per unit area

3.3 Tasks of the notified body

The cornerstones of the actions to be undertaken by the notified body in the procedure of assessment and verification of constancy of performance for the fire proof water trap are laid down in Table 3

Table 3 Control plan for the notified body; corner stones

No	Subject/type of control	Test or control method	Criteria, if any	Minimum number of samples	Minimum frequency of control
Initial inspection of the manufacturing plant and of factory production control					
1	Appearance (trap)	EN 1253-3 table A.1	EN 1253-3 table A.1	EN 1253-3 table A.1	EN 1253-3 table A.1
2	Dimensions (trap)	EN 1253-3 table A.1	EN 1253-3 table A.1	EN 1253-3 table A.1	EN 1253-3 table A.1
3	Materials (trap)	EN 1253-3 table A.1	EN 1253-3 table A.1	EN 1253-3 table A.1	EN 1253-3 table A.1
4	Skirt membrane affixed to the gully	EN 1253-3 table A.1	EN 1253-3 table A.1	EN 1253-3 table A.1	EN 1253-3 table A.1
5	Classification by loading strength (trap and gully)	EN 1253-3 table A.1	EN 1253-3 table A.1	EN 1253-3 table A.1	EN 1253-3 table A.1
6	Raw materials	check			
7	Density	EOTA TR 024 cl. 3.1.4	documentation		
8	Loss of mass at a certain temperature / ash content	EN ISO 3451-1 Methods A (see EOTA TR 024)	Percentage of mass loss after exposure		
9	Ability of a applied layer to create foam at high temperature	EOTA TR 024 clause 3.1.11	description in the ETA		
10	Development of expansion pressure ² during foaming	EOTA TR 024 clause 3.1.12	description in the ETA		
11	Watertight housing for intumescent paste	dimensions			
Continuous surveillance, assessment and evaluation of factory production control					
12	Appearance (trap)	EN 1253-3 table A.1	EN 1253-3 table A.1	EN 1253-3 table A.1	EN 1253-3 table A.1
13	Dimensions (trap)	EN 1253-3 table A.1	EN 1253-3 table A.1	EN 1253-3 table A.1	EN 1253-3 table A.1
14	Materials (trap)	EN 1253-3 table A.1	EN 1253-3 table A.1	EN 1253-3 table A.1	EN 1253-3 table A.1
15	Skirt membrane affixed to the gully	EN 1253-3 table A.1	EN 1253-3 table A.1	EN 1253-3 table A.1	EN 1253-3 table A.1
16	Classification by loading strength (trap and gully)	EN 1253-3 table A.1	EN 1253-3 table A.1	EN 1253-3 table A.1	EN 1253-3 table A.1
17	Density	EOTA TR 024 cl. 3.1.4	description in the ETA	3	2/a
18	Loss of mass at a certain temperature / ash content	EN ISO 3451-1 method A (see EOTA TR 024)	description in the ETA	3	2/a

No	Subject/type of control	Test or control method	Criteria, if any	Minimum number of samples	Minimum frequency of control
19	Ability of a applied layer to create foam at high temperature	EOTA TR 024 clause 3.1.11	description in the ETA	6	2/a
20	Development of expansion pressure ² during foaming	EOTA TR 024 clause 3.1.12	description in the ETA	10	2/a
21	Watertight housing for intumescent paste	dimensions	description in the ETA/ control plan	3	2/a

4 REFERENCE DOCUMENTS

As far as no edition date is given in the list of standards thereafter, the standard in its current version at the time of issuing the European Technical Assessment, is of relevance

EN 1253-1	Gullies for buildings – Part 1: Requirements
EN 1253-2	Gullies for buildings – Part 2: Test methods
EN 1253-23	Gullies for buildings – Part 3: Quality control
EN 13501-1	Fire classification of construction products and building elements - Part 1: Classification using test data from fire reaction to fire tests
EN 13501-2	Fire classification of construction products and building elements - Part 2: Classification using data from fire resistance tests, excluding ventilation services
EN 1366-3	Fire resistance tests for service installations - Part 3: Penetration seals
EN 11925-2	Reaction to fire tests – Ignitability of building products subjected to direct impingement of flame – Part 2: Single-flame source test
EN 13823	Reaction to fire tests for building products - Building products excluding floorings exposed to the thermal attack by a single burning item
EN 1182	Reaction to fire tests for products - Non-combustibility test
EN ISO 1716	Reaction to fire tests for products - Determination of the gross heat of combustion (calorific value)
EN 13823	Reaction to fire tests for building products - Building products excluding floorings exposed to the thermal attack by a single burning item

ANNEX A SPECIFICATION OF THE CONSTRUCTION PRODUCT

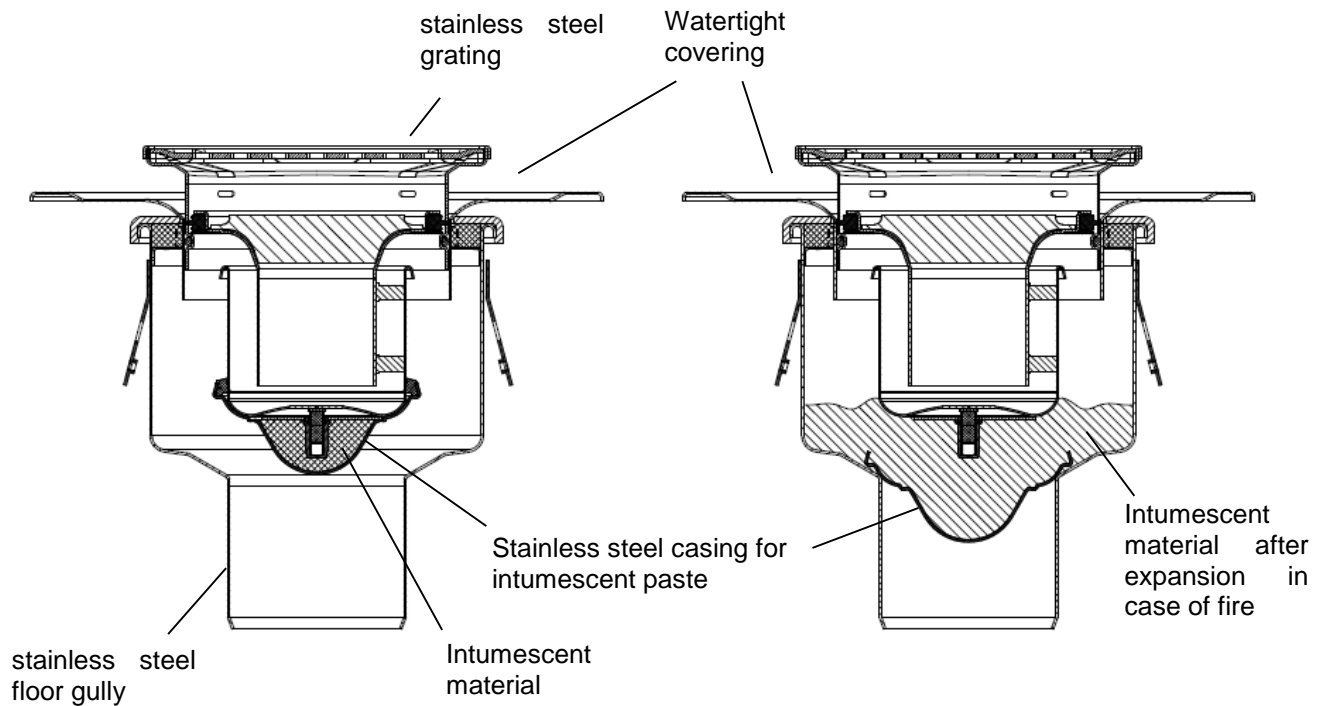
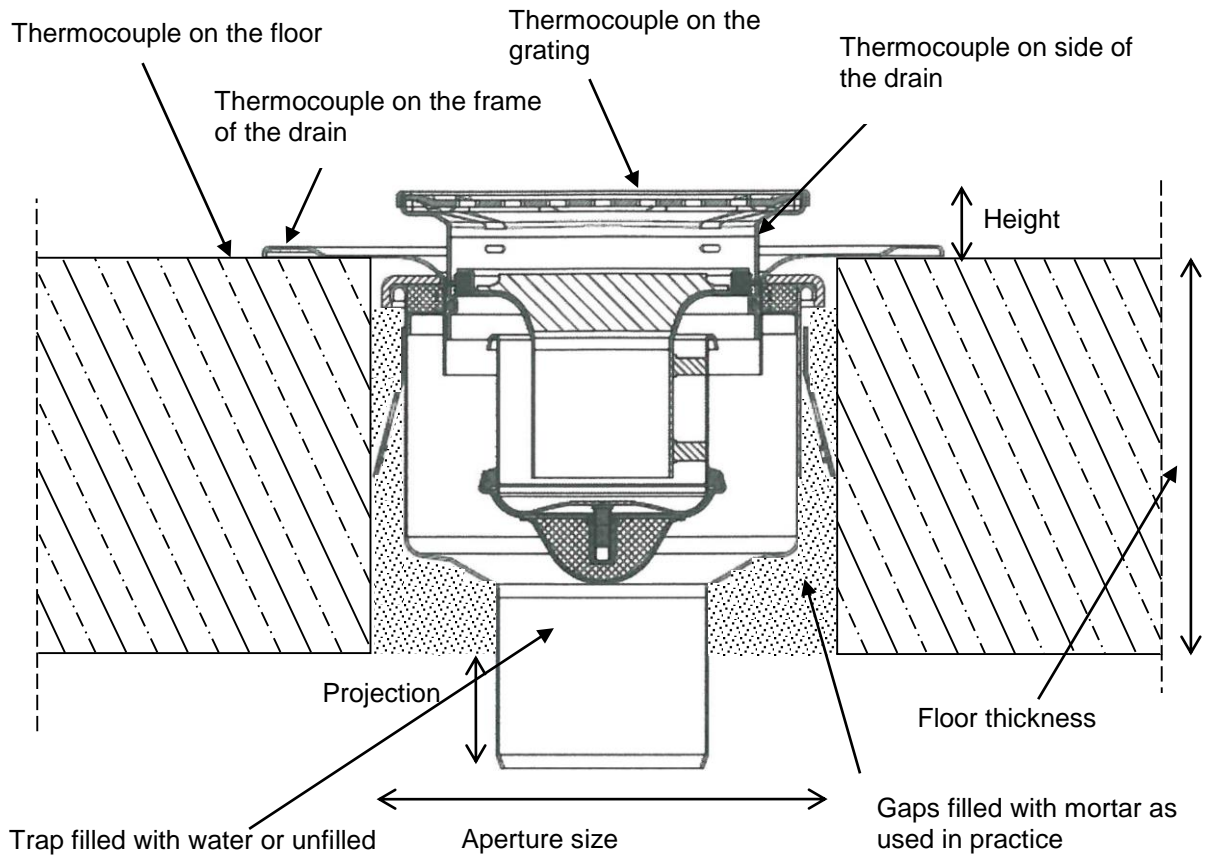

Table A1: intumescent paste

No	Product characteristic	Method	Characteristic
1	Viscosity*	EN ISO 3219; EN 12092	viscosity
2	Density*	ISO 2811	density
3	Loss of mass at a certain temperature / ash content	EN ISO 3451-1 or the standard applied at a certain temperature (see EOTA TR 024)	Percentage of mass loss after exposure
4	Content of non-volatile components	EN ISO 3251, EN 13820	Percentage of volatile matter
5	Ability of an applied layer to create foam at high temperature	EOTA TR 024 clause 3.1.11	Expansion ratio**)
6	Development of expansion pressure ² during foaming	EOTA TR 024 clause 3.1.12	Expansion pressure**)
7	Fingerprint of dry layer	EOTA TR 024 clause 3.1.9	Specific diagram (TG/TGA; IR spectroscopy etc)
*) It is sufficient to test viscosity <u>or</u> density			
**) This characteristic is also related to the Basic Works Requirements			

ANNEX B TEST SETUP FOR THE FIRE RESISTANCE TEST ACCORDING TO EN 1366-3



Two test specimen: one drain shall be connected to a straight metal pipe with a minimum length of 500 mm with a capped pipe end and one drain shall be tested without