



EUROPEAN ASSESSMENT DOCUMENT

EAD 350022-01-1107

January 2018

KIT FOR CLOSURE SYSTEM FOR CONVEYOR SYSTEMS

The reference title and language for this EAD is English. The applicable rules of copyright refer to the document elaborated in and published by EOTA.

This European Assessment Document (EAD) has been developed taking into account up-to-date technical and scientific knowledge at the time of issue and is published in accordance with the relevant provisions of Regulation (EU) 305/2011 as a basis for the preparation and issuing of European Technical Assessments (ETA).

Contents

1	Scope of the EAD	4
1.1	Description of the construction product	4
1.2	Information on the intended use of the construction product	7
1.2.1	Intended use.....	7
1.2.2	Working life/Durability.....	8
1.3	Specific terms used in this EAD	8
2	Essential characteristics and relevant assessment methods and criteria	10
2.1	Essential characteristics of the product	10
2.2	Methods and criteria for assessing the performance of the product in relation to essential characteristics of the product.....	10
2.2.1	Resistance to fire.....	10
2.2.2	Mechanical durability of self-closing systems	10
2.2.3	Reaction to fire	10
2.2.4	Content, emissions and/or release of dangerous substances of the kit components.....	11
3	Assessment and verification of constancy of performance	11
3.1	System of assessment and verification of constancy of performance to be applied.....	12
3.2	Tasks of the manufacturer.....	12
3.3	Tasks of the notified body.....	13
4	Reference documents	14
Annex A	Deviations and additions concerning fire resistance test	15
A.1	Deviations/specifications concerning EN 1366-7	15
A.2	Additions to the field of direct application	22
Annex B	Additional provisions for testing mechanical durability of self-closing	25
B.1	Design of the test specimen	25
B.2	Tests for flaps with different orientations of hinges	25
B.3	Type with electromotive opening aid	25
B.4	Type with electromotive opening and closing.....	25

1 SCOPE OF THE EAD

1.1 Description of the construction product

The closure system can be designed to close vertically or horizontally in internal walls and floors. The closure system primarily consists of the following components:

- Movable element

The movable element consists of either a flap leaf (single-leaf or double-leaf) with hinges or a sliding leaf (single-leaf or double-leaf) with a guide system (simple slide or guide wheel system). The flap leaf and the double-leaf sliding leaf are equipped with locking devices keeping the flap leaf/sliding leaf shut after closing. The flap leaf/sliding leaf may be equipped with a sealing block in the area of the continuous conveyor system. Each flap leaf/sliding leaf overlaps the respective supporting construction by a defined rate.

The flap leaf/sliding leaf may be equipped with additional flap or slide elements for closing residual openings. These additional elements shall be actuated by mechanical or thermal devices (triggering at an ambient air temperature of around 70 °C from both sides of the closure). As thermal devices do not react to cold smoke, they are only used for small residual openings (see annex A.2.8).

- Fixed panel with clearance for the conveyor

The fixed panel is erected either on the floor or it is fixed to the supporting construction via brackets or using direct screw connections. The recess in the fixed panel is fitted to the respective conveyor system. Various intumescent materials are used to close necessary functional gaps. If applicable, a cable penetration can be inserted in the fixed panel or inside the continuous profiles of the conveyor system.

- Frame and locking device of the flap leaf

The movable element is fixed to the supporting construction via a frame or guide or be screwed to it directly. The movable element is kept closed by a locking device and/or additional claw fasteners.

- Seal system

Unavoidable residual functional gaps between the movable element and

- the supporting construction (W),
- the fixed panel (S2) or
- the continuous conveyor system (S1)

are closed by intumescent materials.

- Closing device

The movable element is opened manually or by auxiliary energy (e.g. spring tension, electromotive, pneumatic or hydraulic drive); additional balance weights may be used.

The movable element is closed via stored mechanical energy (closing weight, deadweight of the movable element, spring systems) or drive motor.

Note: Hold-open devices and free travel controls are not part of this EAD.

- Optional cable penetration seal

The fixed panel contains cable penetrations for cables necessary for controlling the kit or conveyor system (free travel control).

The dimensions of the cable penetrations are limited as follows: maximum clear width = 0,3 m; maximum clear height = 0,3 m; maximum clear area: 0,0165 m² (see Annex A.1.1). Their number is limited to two cable penetrations per conveyor section.

The following products are used as cable penetration seals:

- a) cable penetration seals with a European Technical Assessment (ETA)
- b) cable penetration seals assessed together with the kit for closure systems for conveyor systems (see Annex A.1.1)

The cable penetration seals are closed during normal operation.

In case a) the minimum distances between the individual cable penetrations as well as between the cable penetration and the edge of the fixed panel given in the particular ETA apply. In case b) the distances are bigger or equal to the tested distances. In both cases the minimum distances exceed 100 mm.

- Anti-drop protection for upward sliding leaves (installation in walls)

If the sliding element closes upwards, it is secured so that it is kept in the closed position even if the force-transmitting elements (e.g. belts, chains or ropes) fail (herein after referred to as "anti-drop protection").

Steel chains and ropes designed in accordance with structural fire design requirements are able to maintain the movable element in the closed position in case of fire. Therefore no additional protection system is needed.

The following figures show schematically the types of kits treated in this EAD.

Legend

- | | |
|--|---------------------|
| 1 – fastenings | 2 – frame, guides |
| 3 – wall (supporting construction) | 4 – movable element |
| 5 – seal system | 6 – conveyor system |
| 7 – fixed panel | 8 – closing device |
| 9 – locking device | 10 – hinges |
| 11 – sealing block (in the area of the continuous conveyor techniques) | |

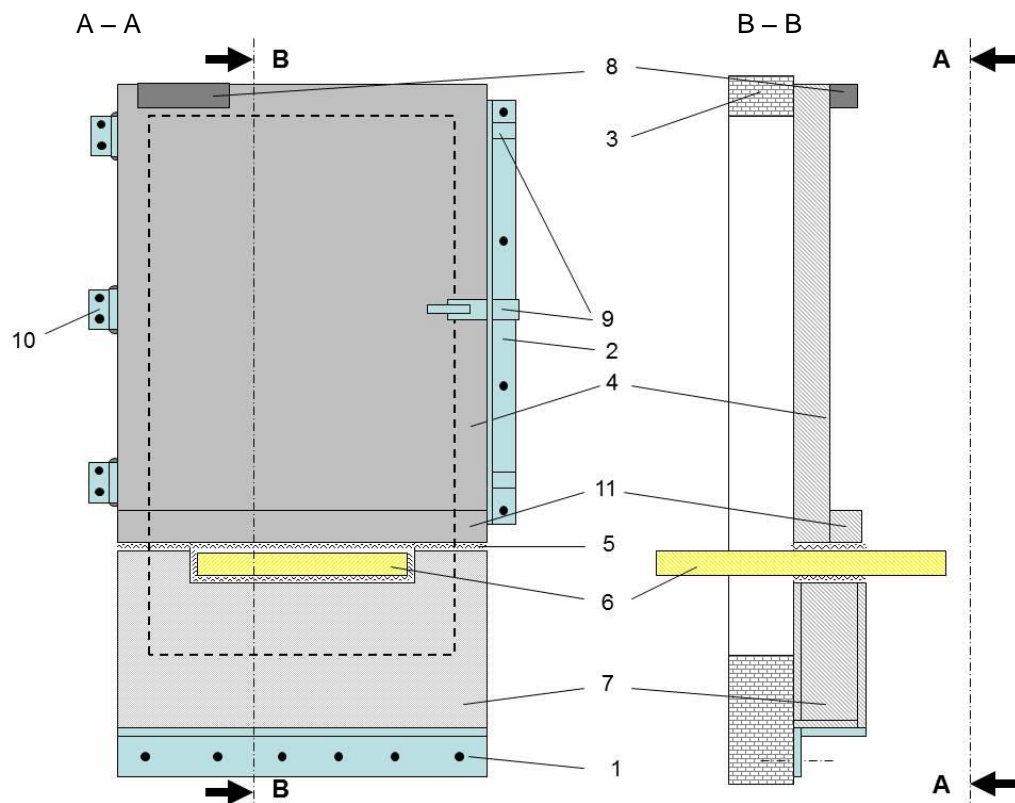

Figure 1: Example for a Kit for closure system for conveyor systems (flap leaf, conveyor continues)

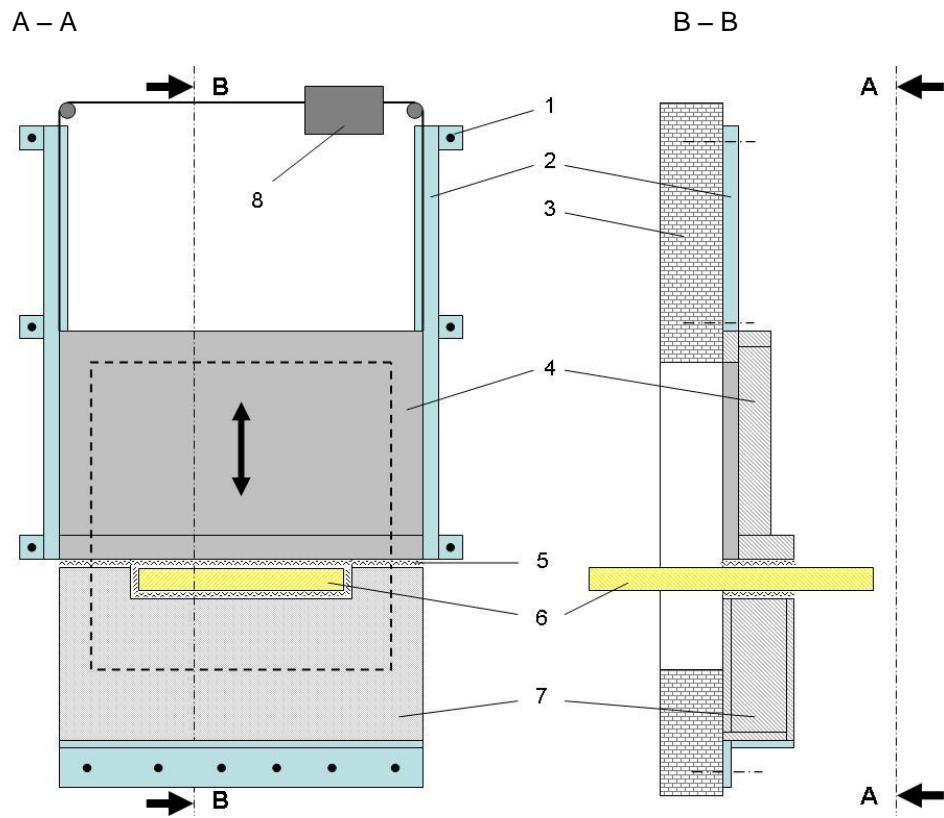

Figure 2a: Example for a Kit for closure system for conveyor systems (sliding leaf, conveyor continues, closing direction vertical)

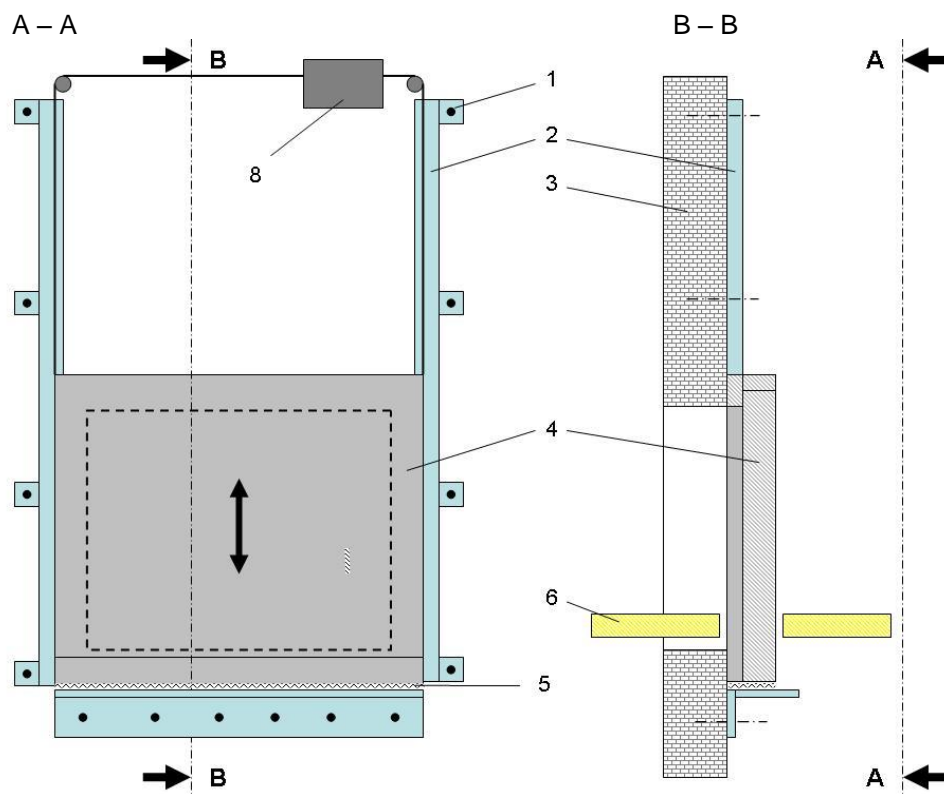

Figure 2b: Example for a Kit for closure system for conveyor systems (sliding leaf, conveyor disconnected, closing direction vertical)

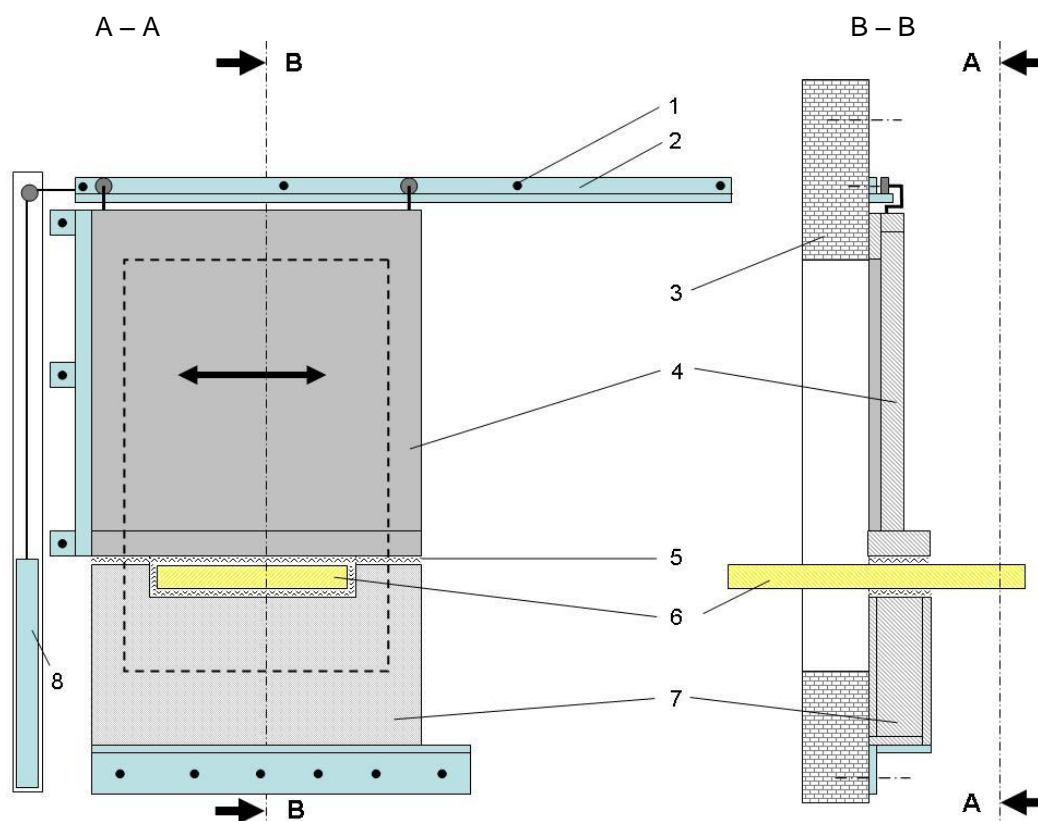

Figure 2c: Example for a Kit for closure system for conveyor systems (sliding leaf, conveyor continues, closing direction horizontal)

The Kit for closure system for conveyor systems are produced as single-unit production in a factory and installed on site according to mounting guidelines. Manufacture of the components at the factory is subject to factory production control.

The product is not covered by a harmonised European standard (hEN).

Concerning product packaging, transport, storage, maintenance, replacement and repair it is the responsibility of the manufacturer to undertake the appropriate measures and to advise his clients on the transport, storage, maintenance, replacement and repair of the product as he considers necessary.

It is assumed that the product will be installed according to the manufacturer's instructions or (in absence of such instructions) according to the usual practice of the building professionals.

Relevant manufacturer's stipulations having influence on the performance of the product covered by this European Assessment Document shall be considered for the determination of the performance and detailed in the ETA.

This EAD only contains the assessment of essential characteristics relevant in accordance with Regulation (EU) No 305/2011. The EAD does not include the assessment on characteristics which are covered by other EU directives such as i.e. low voltage, machinery.

1.2 Information on the intended use of the construction product

1.2.1 Intended use

The Kit for closure system for conveyor systems is intended to be used for closing off necessary openings of trackbound conveyors in internal separating walls or floors. It is used to close the opening in such a way that fire resistance of a wall/floor is ensured.

The Kit for closure system for conveyor systems according this EAD is not intended for passenger transportation.

The normal position of the closure shall be opened or closed. In the place of the closure the conveyor shall either be continued or discontinued or disconnected while closing of the closure. The position of the conveyor with regards to the closure shall either be at the top, at the bottom, on the sides or in the middle.

Generally, the application is restricted to category Z₂ according to TR024.¹ For other categories suitable proofs for the performances of the used materials and components shall be provided.

1.2.2 Working life/Durability

The assessment methods included or referred to in this EAD have been written based on the manufacturer's request to take into account a working life of the kit for closure system for conveyor systems for the intended use of 10 years when installed in the works provided that the kit for closure system for conveyor systems is subject to appropriate installation (see 1.1). These provisions are based upon the current state of the art and the available knowledge and experience.

When assessing the product the intended use as foreseen by the manufacturer shall be taken into account. The real working life may be, in normal use conditions, considerably longer without major degradation affecting the basic requirements for works².

The indications given as to the working life of the construction product cannot be interpreted as a guarantee neither given by the product manufacturer or his representative nor by EOTA when drafting this EAD nor by the Technical Assessment Body issuing an ETA based on this EAD, but are regarded only as a means for expressing the expected economically reasonable working life of the product.

1.3 Specific terms used in this EAD

Movable element

movable part of the kit that will be closed in the case of fire (flap leaf, sliding leaf) (see Fig. 1)

Fixed panel

fixed part of the kit connected to the supporting construction with openings/recesses for the conveyor system (see Fig. 1)

Sealing block

enlargement on the movable element in the area of the continuous conveyor techniques (see Fig. 1)

Panel

part of the movable element

Frame

device that ensures the close connection between movable element and supporting construction (see Fig. 1)

Guide

device that ensures moving of the movable element

Anti-drop system

Device for upward sliding leaves ensuring that the movable element is kept in the closed position in case of failure of the force-transmitting devices (e.g. belts)

Sealing system

system for sealing unavoidable residual functional gaps when the movable element is in closed position by means of intumescent materials (see Fig. 1)

¹ TR024-2009 Characterisation, Aspects of Durability and Factory Production Control for Reactive Materials, Components and Products):
Typ Z₂: intended for use at internal conditions with humidity classes other than Z₁, excluding temperatures below 0°C.

² The real working life of a product incorporated in a specific works depends on the environmental conditions to which that works is subject, as well as on the particular conditions of the design, execution, use and maintenance of that works. Therefore, it cannot be excluded that in certain cases the real working life of the product may also be shorter than referred to above.

Intumescent material

material that reacts chemically in the event of fire by creating foam

Closing device

a device (mechanism) to close the movable element (see Fig. 1)

Fixing material

means for fixing the frame or the hinges at a supporting construction

Supporting construction

inner walls and floors of buildings (see Fig. 1)

Cable penetration seals

fire resistant closure system in the fixed panel for cables necessary for controlling the kit or the conveyor system in the closing area of the closure (see Annex A.1.1)

Additional flap or slide elements

additional devices of the movable element for closing of residual openings

Hold-open device

combination of compatible elements, which has the function to hold open self-closing closures

Conveyor system

device for transport of materials through an opening in a supporting construction (see Fig. 1)

Closing area

area which is necessary for the correct closing of the closure; shall be kept free in the event of closing of the closure

Safety system for monitoring the closing area

Devices (suitable sensors, such as light barriers), which are not shut down in case of a fire alarm or a malfunction or when triggered manually; they have to delay or interrupt the shutting of the movable element if obstacles are detected in the closing area.

Drive control unit

Part of an electromotive drive system which processes the signals emitted by the fire detection devices and safety systems and triggers the shutting of the movable element under specific conditions.

Motor drive

Device of an electromotive drive system which opens and/or closes the movable element if it receives the relevant signal from the drive control unit

Power supply

Device of an electromotive drive system ensuring the power supply of the fire alarms, the drive control unit, the motor drive and, where applicable, the safety systems. The system is fitted with a second standby power supply which takes over in case of a power outage.

Electromotive drive system for opening and closing of the movable element

System consisting of a drive control unit, a motor drive, a power supply (including a second standby power supply), appropriate fire detection devices which initiate the closing of the movable element and, if applicable, a safety system for monitoring the closing area

2 ESSENTIAL CHARACTERISTICS AND RELEVANT ASSESSMENT METHODS AND CRITERIA

2.1 Essential characteristics of the product

Table 1 shows how the performance of the Kit for closure system for conveyor systems is assessed in relation to the essential characteristics.

Table 1 Essential characteristics of the product and methods and criteria for assessing the performance of the product in relation to those essential characteristics

No	Essential characteristic	Assessment method	Type of expression of product performance
Basic Works Requirement 2: Safety in case of fire			
1	Resistance to fire	see clause 2.2.1	class
2	Mechanical durability of self-closing	see clause 2.2.2	class
3	Reaction to fire	see clause 2.2.3	class
Basic Works Requirement 3: Hygiene, health and the environment			
4	Content, emission and/or release of dangerous substances	see clause 2.2.4	description

2.2 Methods and criteria for assessing the performance of the product in relation to essential characteristics of the product

2.2.1 Resistance to fire

The kit for closure system for conveyor systems shall be tested in accordance with EN 1366-7. As some questions concerning the testing and the field of direct application of the test results are not sufficiently treated in EN 1366-7, the additional provisions in Annex A shall apply.

The kit for closure system for conveyor systems shall be classified according EN 13501-2.

2.2.2 Mechanical durability of self-closing systems

The mechanical durability of self-closing systems shall be tested in accordance with EN 12605. As some questions concerning the testing and the field of direct application of the test results are not sufficiently treated in EN 12605, the additional provisions in Annex B shall apply.

The kit for closure system for conveyor systems shall be classified in accordance with EN 13501-2 and EN 16034:2014 (table 1 on section 4.5.2.1 – number of opening and closing).

2.2.3 Reaction to fire

The constituents of the kit for closure system for conveyor systems shall be tested, using the test method(s) according to EN 13501-1 and relevant for the corresponding reaction to fire class., They shall be classified according to Commission Delegated Regulation (EU) 2016/364 in connection with EN 13501-1. Verifications in line with European Technical Assessments may be used. Provisions of EC Decision 96/603/EC as amended and EC Decisions concerning CWFT products should be considered if applicable.

2.2.4 Content, emissions and/or release of dangerous substances

The performance of the kit related to the emissions and/or release and, where appropriate, the content of dangerous substances will be assessed on the basis of the information provided by the manufacturer³ after identifying the release scenarios (in accordance with EOTA TR 034) taking into account the intended use of the product and the Member States where the manufacturer intends his product to be made available on the market.

The identified intended release scenarios for this product and intended use with respect to dangerous substances are:

IA 1: Product with direct contact to indoor air.

IA 2: Product with indirect contact to indoor air (e.g covered products) but possible impact on indoor air.

- **SVOC and VOC**

Semi-volatile organic compounds (SVOC) and volatile organic compounds (VOC) are to be determined in accordance with EN 16516. The loading factor to be used for emission testing is 0,007 m²/m³.

The closure system to be tested shall be assembled according to the envisaged application, with all components (including fastenings, frame, movable elements, seal system, conveyor system, tensile elements) being part of the test specimen. The installation should be in accordance with the manufacturer's product installation instructions or (in absence of such instructions) the usual practice of installation. Once the test specimen has been produced, as described above, it should immediately be placed in the emission test chamber. This time is considered the starting time of the emission test.

The test results have to be reported for the relevant parameters (e.g. chamber size, temperature and relative humidity, air exchange rate, loading factor, size of test specimen, conditioning, production date, arrival date, test period, test result) after 3 and 28 days testing.

The relevant test results shall be expressed in [mg/m³] and stated in the ETA.

³ The manufacturer may be asked to provide to the TAB the REACH related information which he must accompany the DoP with (cf. Article 6(5) of Regulation (EU) No 305/2011).

The manufacturer is **not** obliged:

- to provide the chemical constitution and composition of the product (or of constituents of the product) to the TAB, or
- to provide a written declaration to the TAB stating whether the product (or constituents of the product) contain(s) substances which are classified as dangerous according to Directive 67/548/EEC and Regulation (EC) No 1272/2008 and listed in the "Indicative list on dangerous substances" of the SGDS.

Any information provided by the manufacturer regarding the chemical composition of the products may not be distributed to EOTA or to TABs.

3 ASSESSMENT AND VERIFICATION OF CONSTANCY OF PERFORMANCE

3.1 System of assessment and verification of constancy of performance to be applied

For the products covered by this EAD the applicable European legal act is: Decision 1999/454/EC.

The system is 1 for any use except for uses subject to regulations on reaction to fire performance.

For uses subject to regulations on reaction to fire the applicable AVCP systems are 1, 3 or 4 depending on the conditions defined in the said Decision.

3.2 Tasks of the manufacturer

The cornerstones of the actions to be undertaken by the manufacturer of the product in the procedure of assessment and verification of constancy of performance are laid down in Table 2.

Table 2 Control plan for the manufacturer; cornerstones

No	Subject/type of control	Test or control method	Criteria, if any	Minimum number of samples	Minimum frequency of control
Factory production control (FPC) [including testing of samples taken at the factory in accordance with a prescribed test plan]*					
1	checking of the incoming materials and components <ul style="list-style-type: none"> – precise designation and relevant characteristics of the material or component – if possible references to European and/or international standards or relevant specifications – inspection of the delivery receipt 		compliance with required materials or components		every delivery
2	<ul style="list-style-type: none"> – checking of compliance of actual dimensions with specified dimensions (drawings) of the kit – visual examination + size check 		compliance with required tolerances	1	<ul style="list-style-type: none"> – at the beginning of a production series – at large production series: every day of production – at small series and single unit production: every 30th kit
3	checking of compliance of each kit with the requirements of each individual project		compliance with the project-related requirements	1	every kit

3.3 Tasks of the notified body

The cornerstones of the actions to be undertaken by the notified body in the procedure of assessment and verification of constancy of performance for the kit for closure system for conveyor system are laid down in Table 3.

Table 3 Control plan for the notified body; cornerstones

No	Subject/type of control	Test or control method	Criteria, if any	Minimum number of samples	Minimum frequency of control
Initial inspection of the manufacturing plant and of factory production control <i>(for systems 1+, 1 and 2+ only)</i>					
1	inspection of factory and factory production control as described in the control plan of the ETA	control of devices, equipment and documentation of the FPC			when starting the production or a new product line
Continuous surveillance, assessment and evaluation of factory production control <i>(for systems 1+, 1 and 2+ only)</i>					
2	checking of the incoming materials <ul style="list-style-type: none"> – precise designation of the material – if possible references to European and/or international standards or relevant specifications 				twice a year
3	<ul style="list-style-type: none"> – checking of compliance of actual dimensions with specified dimensions (drawings) of the kit – visual examination + size check 		compliance with required tolerances		twice a year

4 REFERENCE DOCUMENTS

As far as no edition date is given in the list of standards thereafter, the standard in its current version at the time of issuing the European Technical Assessment, is of relevance.

EN 13501–1	Fire classification of construction products and building elements, part 1: Classification using data from reaction to fire tests
EN 13501–2	Fire classification of construction products and building elements, part 2: Classification using data from fire resistance tests, excluding ventilation services
EN 1366–7	Fire resistance tests for service installations, Part 7: Conveyor systems and their closures
EN 12605	Industrial, commercial and garage doors and gates – Mechanical aspects – Test methods
EN 16034	Pedestrian doorsets, industrial, commercial, garage doors and openable windows – Product standard, performance characteristics – Fire resistance and/or smoke control characteristics
EOTA TR 034	General checklist for EADs/ETAs – Content and/or release of dangerous substances in construction products

ANNEX A DEVIATIONS AND ADDITIONS CONCERNING FIRE RESISTANCE TEST

A.1 Deviations/specifications concerning EN 1366-7

A.1.1 Cable penetration seal

As the testing of cable penetration seals is not sufficiently treated in EN 1366-7, the following approaches are possible for the products listed in section 1.1:

- a) cable penetration seals with European Technical Assessment (ETA)
Cable penetration seals shall be tested for fire resistance at least once together with the whole kit (installed in a wall and/or floor⁴) and with the maximum permitted cable configuration (in accordance with the relevant ETA). The cable penetration seals shall be completely closed in accordance with the installation instruction.
- b) cable penetration seals assessed together with the kit for closure for conveyor system
In this approach, the cable penetration seals shall be tested together with the whole kit in a fire resistance test in accordance with EN 1366-7 and shall meet the requirements specified in EN 1366-3 (installation in a fixed panel attached to a wall and/or floor⁴). If the pressure conditions specified in EN 1366-3 cannot be met due to the position of the installation in the overall system (e.g. installation in a fixed panel positioned below the movable element), a part configuration test may be carried out.

The test shall be carried out with the maximum permitted cable configuration for the cable penetration (in accordance with EN 1366-3). The cable penetration seals shall be completely closed in accordance with the installation instructions.

For the intended type of the closure with several cable penetration seals in a single fixed panel at least two cable penetration seals with minimal intended distance (>100 mm) shall be incorporated in the test specimen.

For the intended type of the closure with cable penetration seals in the area of the continuous conveyor systems (installation inside the continuous profiles) such a cable penetration shall additionally be incorporated in the test specimen.

A.1.2 Dimensions of the test specimen

The test specimen shall have maximum dimensions taking into account the field of direct application. Section 13.3.3 and Annex B3 of EN 1366-7 shall not apply given that sufficiently big test furnaces are available.

A.1.3 Design of the test specimen

The following examples shall be added to the design provision for the test specimen given in section 6.3 of EN 1363-1:

"No variation in construction (e.g. different jointing systems) shall be included in a single test specimen"

(1) Spacing of the fastenings attaching the installation to the supporting construction

If the fastenings are spaced unevenly, the test result obtained for the test specimen as a whole shall be taken into account (e.g. the test results from the side where the fastenings are closer together cannot be extended to the test specimen as a whole, even if a smaller spacing is intended to be used for all fastenings.)

(2) Use of different materials

Test specimens may only include discrete areas made of different materials if their installation in the closure is necessary (e.g. locking devices). Their use is not permitted if the purpose is to allow for the testing of variations in construction in a single test specimen.

⁴ Only the installed positions the kit is intended and was tested for shall be tested.

A.1.4 Number of the test specimen



The following tests usually have to be carried out for each design and each supporting construction of the subject of assessment:

- (1) Fire exposure from the side including the hinges or guides of the closure
- (2) Fire exposure from the side not including the hinges or guides of the closure

The provisions laid down in section 13.5.7 of EN 1366-7 shall not apply. In accordance with section 7.1.2.2 of EN 13501-2, the following derogations are possible:

- If the closure is intended for installation in walls, the fire exposure test from the less critical side may be replaced by an expert opinion issued by the testing laboratory (see table A1a)⁵

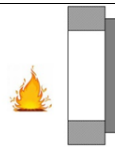
Table A1a: Installation in a wall – permitted extension of results of fire resistance tests⁶



Intended use as stated in the application →		Installation in a wall
necessary tests according EN 1366-7 incl. commitments of this EAD ↓		
Installation location	fire exposure	
Wall	 <u>not</u> from the side with hinges or guides	fire resistance test or expert opinion ⁵
	 from the side with hinges or guides	fire resistance test or expert opinion ⁵

- If the closure is intended for installation on top of the floor, the fire exposure test from above may be replaced by an expert opinion issued by the testing laboratory (see table A1b)⁵.
- If the closure is intended for installation below the floor, the fire exposure test from above may be replaced by an expert opinion issued by the testing laboratory (see table A1b)⁵.
- If the closure is intended for installation on top of or below the floor, the fire exposure tests from above or below in case of installation on top of the floor and the fire exposure test from above in case of installation below the floor may be replaced by an expert opinion issued by a testing laboratory (see table A1b)⁵.

Table A1b: Installation in floors - Permitted extension of results from fire exposure tests⁶

⁵ Expert opinion issued by a testing laboratory having carried out at least one test with regard to the subject of assessment (see EN 13501-2, section 7.1.2.2). If the testing laboratory has relevant testing experience (e.g. acquired by carrying out tests with identical or similar test specimens for the same applicant) it may determine the more critical side, which shall then be tested. The reasons for assuming that the side chosen is most critical shall be stated in the expert opinion.

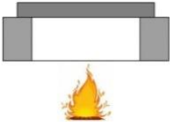
⁶ The test results may be extended provided that the design of the subject of assessment (including use of identical guide elements such as rails, slide rails or hinges) as well as the design of the supporting construction (solid/high density, solid/low density, lightweight construction) remain unchanged.

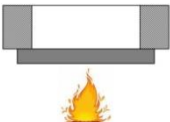
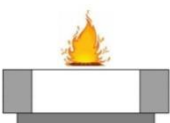
Intended uses as stated in the application→		on top of the floor	below the floor	on top of or below the floor
Tests required in accordance with EN 1366-7 taking into account the provisions laid down in this EAD ↓				
Location	Fire exposure			
on top of the floor	 from below	<u>Fire resistance test</u>	No fire resistance test required	Fire resistance test or expert opinion ⁵
	 from above	Fire resistance test or expert opinion ⁵	No fire resistance test required	Fire resistance test or expert opinion ⁵
below the floor	 from below	No fire resistance test required	<u>Fire resistance test</u>	<u>Fire resistance test</u>
	 from above	No fire resistance test required	Fire resistance test or expert opinion ⁵	Fire resistance test or expert opinion ⁵

A.1.5 Action of hot gases passing through the specimen

The reference to EN 1363-1 in section 9.1.2.1 of EN 1366-7 (concerning thermocouples attached to the unexposed face heated by hot gases) shall not apply for the required measuring points on the continuous conveyor system, i.e. the values obtained at these temperature measuring points shall be taken into account even in case of hot gases flowing through.

However, the reference to standard EN 1363-1 in section 9.1.2.1 of EN 1366-7 may be used in case the substrate/surface starts showing initial cracks directly at the measuring points during the test affecting the thermocouples.

A.1.6 Maximum temperature on the frame/guide

The test specimen shall be evaluated against the maximum temperature rise criterion (180 K) specified in EN 1363-1. The derogations for frames and guides specified in section 11.2.2 of EN 1366-7 shall not apply.

A.1.7 Maximum temperature on the conveyor Systems

For penetrating conveyor tracks, thermocouples for maximum temperature rise only shall be positioned at a distance of 50 mm from the movable element. The distance from the supporting construction specified in section 9.1.2.5 of EN 1366-7 together with Figure 9 is irrelevant.

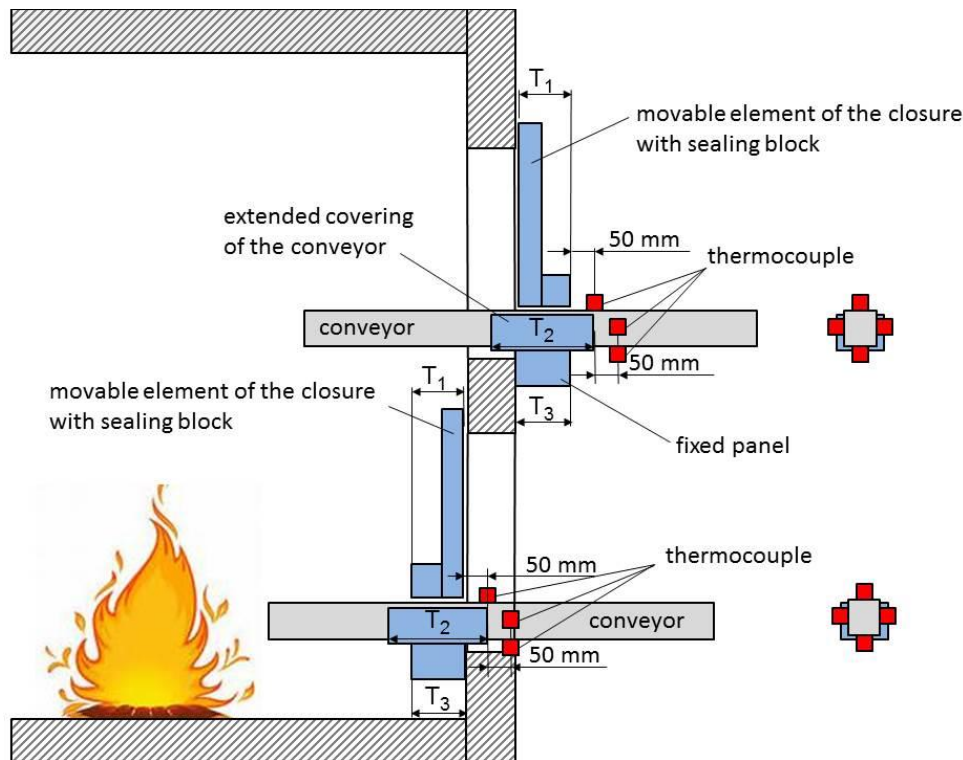

Figure A1: location of the thermocouples on the conveyor

Explanatory note on figure A1

The following dimensions shall be specified in the test report and in the European Technical Assessment.

- T1 – Depth of the sealing block on the movable element (including movable element)
- T2 – Depth of an extended, fixed, incomplete covering of the conveyor system (the conveyor system usually has no casing in direction of the movable element)
- T3 – depth of the actual fixed panel

A.1.8 Field of direct application – limits of permitted size variation

If the testing laboratories recommend permitted size variations, they have to state the reasons for these recommendations⁷. The provisions regarding permitted size variations given in section 13.3 of EN 1634-1 together with Annex B shall be amended and supplemented as follows:

⁷ Expert opinion issued by a testing laboratory having carried out at least one test with regard to the subject of assessment. The reasons for recommending permitted size variations shall be stated in the expert opinion.

Table A2: Field of direct application - Limits of permitted size variations (replacement for Table B.1 in EN 1634-1

Type of closure	Category 'A' allowances	Category 'B' allowances
Hinged or pivoted closures in walls	Unlimited size reduction is permitted for all types except insulated metal closures for which the size reduction is limited to 50 % for the side perpendicular to the hinge side and 75 % for the hinge side of the tested specimen. Size increase is not permitted.	Unlimited size reduction is permitted for all types except insulated metal closures for which the size reduction is limited to 50 % for the side perpendicular to the hinge side and 75 % for the hinge side of the tested specimen. Size increase is permitted to the limit of: <ul style="list-style-type: none"> – 15 % for the lateral length and – 20 % area increase. This does not apply for closures which satisfy the criteria for radiation protection.
Hinged or pivoted closures in floors	Unlimited size reduction is permitted for all types except insulated metal closures for which the size reduction is limited to 50 % for the side perpendicular to the hinge side and 75 % for the hinge side of the tested specimen. Size increase is not permitted.	Unlimited size reduction is permitted for all types except insulated metal closures for which the size reduction is limited to 50 % for the side perpendicular to the hinge side and 75 % for the hinge side of the tested specimen. Size increase is permitted to the limit of: <ul style="list-style-type: none"> – 15 % for the lateral length and – 20 % area increase. This does not apply for closures which satisfy the criteria for radiation protection.
Horizontally and vertically sliding closures in walls	Unlimited size reduction is permitted for all types except insulated metal closures for which the size reduction is limited to 50% of the width and 75% of the height of the tested specimen. Size increase is not permitted.	Unlimited size reduction is permitted for all types. Size increase is permitted to the limit of: <ul style="list-style-type: none"> – 50 % for the lateral length and – 50 % area increase. This does not apply for closures which satisfy the criteria for radiation protection.
Horizontally and vertically sliding closures in floors	Unlimited size reduction is permitted for all types except insulated metal closures for which the size reduction is limited to 50 % for the unguided side and 75 % for the guided side of the tested specimen. Size increase is not permitted.	Unlimited size reduction is permitted for all types except insulated metal closures for which the size reduction is limited to 50 % for the unguided side and 75 % for the guided side of the tested specimen. Size increase is permitted to the limit of: <ul style="list-style-type: none"> – 15 % for the lateral length and – 20 % area increase. This does not apply for closures which satisfy the criteria for radiation protection.

A.1.9 Additional Criteria for "otherwise identical" test specimen

In addition to an identical design of the movable element and of the fixed panel the criteria for "otherwise identical" test specimens are as follows:

- (1) The fixing points for attaching the frame/guide to the supporting construction shall be equally spaced.
- (2) The fixing points for attaching the movable element to the frame/guide shall be equally spaced.
- (3) The fixing points shall be of equal quality⁸ (in the opinion of the testing laboratory⁹)
- (4) The fastening for the fixed panel shall be of equal quality (in the opinion of the testing laboratory⁹)

⁸ A fixing point designates the fastening of the kit to the supporting construction, including all necessary components (e.g. anchors, brackets, fastenings for load-bearing parts such as guides).

⁹ Expert opinion issued by a testing laboratory having carried out at least one test with regard to the subject of assessment. The reasons for concluding that the fixing points are of equal quality shall be stated in the expert opinion.

A.1.10 flexible supporting construction

Flexible constructions within the meaning of this EAD are lightweight plasterboard faced steel stud partitions in accordance with EN 1363-1, clause 7.2.2.4 "Flexible construction". In accordance with the said clause, the design of the supporting construction used during the test shall be described in a drawing. Additionally, the way in which the closure is fixed to the supporting construction shall be documented by a drawing. Furthermore, the following information shall be specified:

- (1) Type of the materials used
- (2) Type of fixing material
- (3) Material and dimensions of the stud partitions

A.1.11 Tolerable gaps prior to the fire resistance test

Dimensions of the gaps between the movable element and

- the supporting construction (W),
- the fixed panel (S2) and
- the continuous conveyor system (S1)

shall be designed and executed as small as possible (see Figure A2).

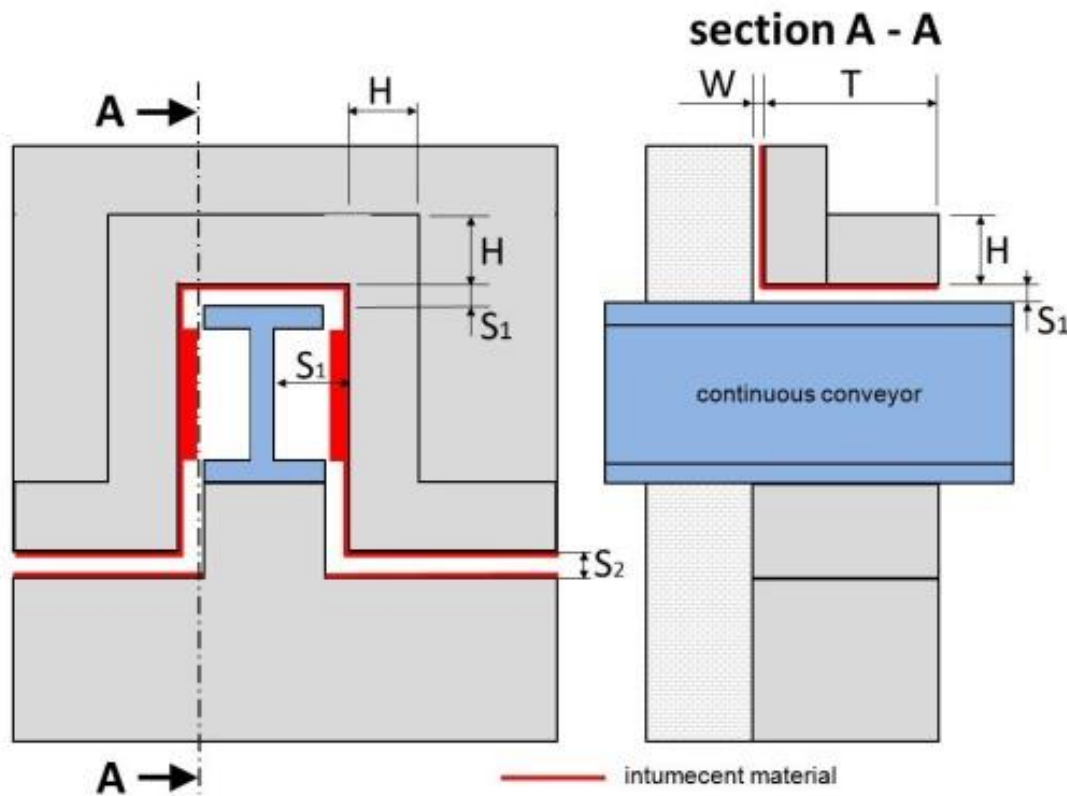

Figure A2: gaps between the movable element and supporting construction (W), fixed panel (S2) and continuous conveyor system (S1)

Residual functional gaps must be closed by intumescent materials if the temperature rises. To this effect, the intumescent materials shall be arranged in the gaps respecting the maximum allowable dimensions given in table A3.

Type, thickness per layer and number of layers of the intumescent materials are to be recorded in the test report in the form of a table as shown in table A3. If the result of the fire resistance test is positive, this table shall become part of the field of direct application. Only materials certified fit for use and tested for fire resistance shall be used.

Table A3: maximum allowable dimensions of functional gaps

gaps between movable element of the closure and					
supporting construction W maximum allowable gap width: 20 mm		fixed panel S2 maximum allowable gap width: 20 mm ¹⁰		continuous conveyor system S1 maximum allowable gap width: 50 mm ¹¹	
intumescent material type: _____ thickness per layer: _____		intumescent material type: _____ thickness per layer: _____		intumescent material type: _____ thickness per layer: _____	
gap [mm]	number of lay- ers	gap [mm]	number of lay- ers	gap [mm]	number of lay- ers
$5 \leq W \leq x1$	n1	$5 \leq S2 \leq x1$	n1	$5 \leq S1 \leq x1$	n1
$x1 < W \leq x2$	n2	$x1 < S2 \leq x2$	n2	$x1 < S1 \leq x2$	n2
$x2 < W \leq 20$	n3	$x2 < S2 \leq 20$	n3	$x2 < S1 \leq 50$	n3

The following shall apply to the use of gap gauges prior to the fire resistance test:

- in gaps between the movable element of the closure and the supporting construction (W) as well as between the movable element of the closure and the fixed panel (S2) a 25 mm gap gauge shall be used; the use of a 6 mm gap gauge is not permitted.
- in gaps between the movable element of the closure and the continuous conveyor system (S1) neither of the two gauges shall be used.

About 5 minutes after the start of the fire resistance test the gap gauges shall be used.

A.1.12 Anti-drop protection for upward sliding leaves

If the sliding leaf closes upwards, it shall be secured so that it is kept in the closed position even if the force-transmitting elements (e.g. belts, chains or ropes) fail.

Steel chains and ropes designed in accordance with structural fire design requirements are able to maintain the movable element in the closed position in case of fire. Therefore, no additional protection system is needed.

Designs using folding supports (made of flat steel) which are pushed up by intumescent materials in case of fire to keep the sliding leaf in the closed position have shown not to work reliably and shall not be used.

¹⁰ If bigger residual gaps are necessary for functional reasons, a testing laboratory having carried out at least one test with regard to the subject of assessment shall evaluate the possibility of closing these gaps by intumescent materials only for the specific conveyor system in question. The functional reasons leading to bigger residual gaps shall be documented.

¹¹ If bigger residual gaps are necessary for functional reasons, a testing laboratory having carried out at least one test with regard to the subject of assessment shall evaluate the possibility of closing these gaps by intumescent materials only for the specific conveyor system in question. Alternatively, these gaps may be closed by appropriate flap elements (see section A.3.4). The functional reasons leading to bigger residual gaps shall be documented.

A.2 Additions to the field of direct application

A.2.1 Number of panels in the movable element

The number of panels per movable element may be reduced provided that the dimensions of the panels lie within the range between the smallest and the largest panel tested.

A.2.2 Dimensions of a panel in the movable element

The width of vertical panels may be reduced within the range between the smallest and the widest panel tested. The height of horizontal panels may be reduced within the range between the smallest and biggest panel height tested.

A.2.3 Thickness of the steel panel covering

The thickness of the steel panel covering may be changed as follows:

- thickness tested: 1,0 mm, valid for thicknesses between 0,75 and 1,00 mm and
- thickness tested: 1,5 mm, valid for thicknesses between 1,00 and 1,50 mm.

A.2.4 Changing the number of movable elements

The test results obtained for horizontally closing double-leaf sliding elements may be transferred to single-leaf sliding elements provided that

- the overlap of the single-leaf sliding element is comparable to that of the double-leaf sliding element (closing edge) and
- all design features have already been tested (in the double-leaf sliding element)

The dimensions of the single-leaf sliding element shall be equal to the dimensions of one leaf of the two-leaf sliding element.

The testing laboratory shall assess whether the test results can be transferred and give a reasoned opinion.¹²

A.2.5 Tolerable gaps in the movable element (except curtains)

Deviations from the rectangular shape shall be assessed by the testing laboratory¹³. The following conditions shall be observed:

- $H2 \geq 1/3 H$
- $H2 \geq 200 \text{ mm}$
- $B2, B4, B6, \geq 1/10 B$
- $B2, B4, B6, \geq 200 \text{ mm}$
- $H7 \geq 1/3 H$
- $H7 \geq 200 \text{ mm}$
- $H5, H3 \geq 1/10 H$
- $H5, H3 \geq 200 \text{ mm}$
- $B8 \geq 1/2 B$
- $B8 \geq 200 \text{ mm}$
- *B1 to B8 and H1 to H7 may be not relevant*

In case of deviation from these conditions, tests (fire resistance, durability) are required.

¹² Expert opinion issued by a testing laboratory having carried out at least one test with regard to the subject of assessment. The reasons for concluding that the test results can be transferred shall be stated in the expert opinion.

¹³ Expert opinion issued by a testing laboratory having carried out at least one test with regard to the subject of assessment. The reasons for permitted deviations from the rectangular shape shall be stated in the expert opinion.

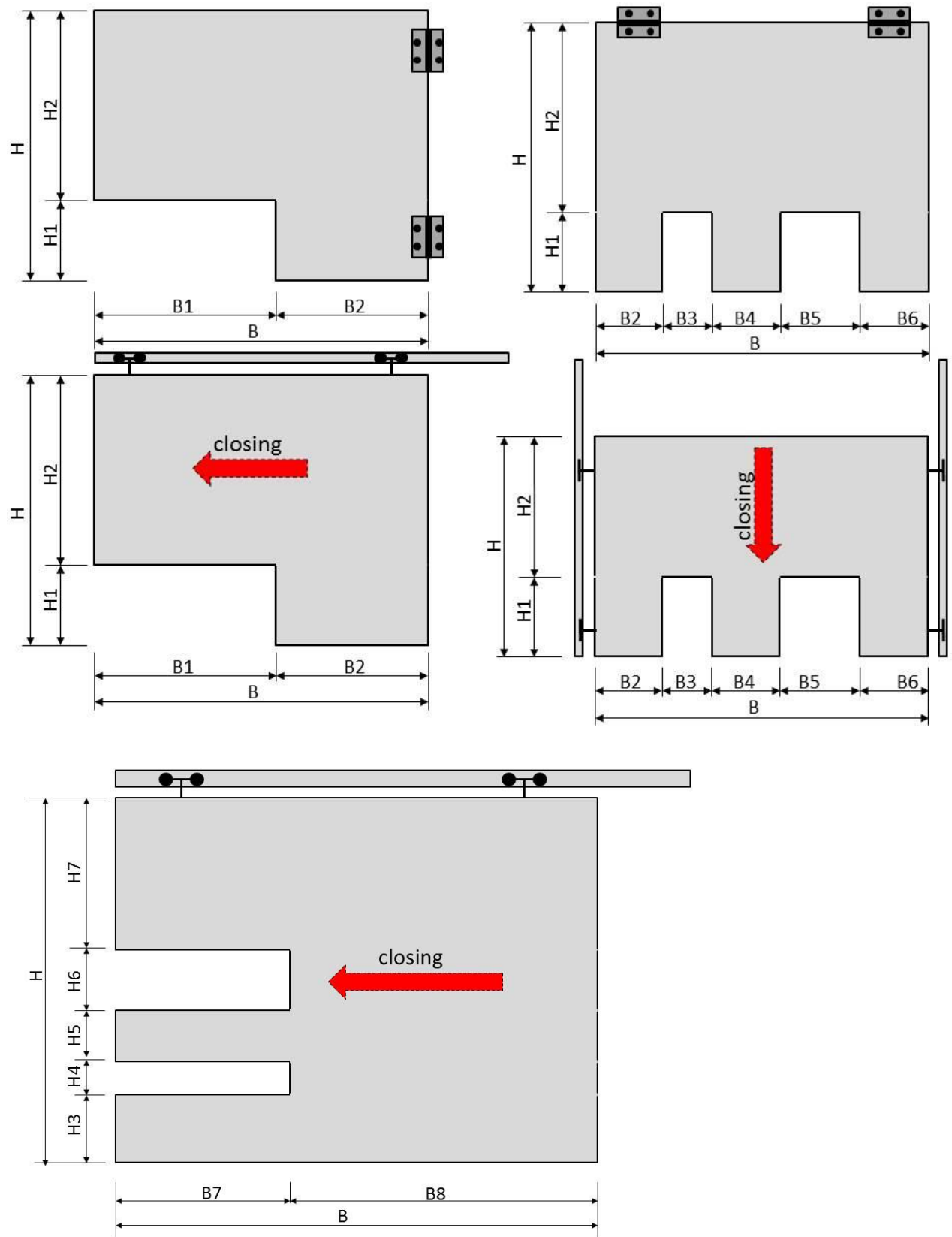

Figure A3: Examples for tolerable gaps in the movable element (above flap leaf, below sliding leaf)

A.2.6 Transferring test results obtained in partial configuration tests for specific conveyor systems

The test results obtained in a partial configuration test for a specific conveyor system shall only be transferred to another type of closure system if:

- the depth (T) of the movable element in direction of the conveyor system is the same (see figure A2)
- the height (H) of the movable element of the closure system is the same (see figure A2)

The testing laboratory shall assess whether the test results can be transferred and give a reasoned opinion.¹²

A.2.7 Use of alternative construction materials

The assessment of alternative construction materials to be used in an otherwise identical design may not be based entirely on expert opinions. In order to ensure comparability, at least one test shall be carried out under the same conditions as in the respective test for the original construction materials, taking into account the following criteria:

- (1) A test in the most critical installed position with exposure from the more critical side shall be sufficient.¹⁴
- (2) The test shall be carried out with the maximum dimensions given in the application as well as with the most critical penetration seal for the continuous conveyor system.¹⁴
- (3) A testing laboratory having carried out at least one test with regard to the subject of assessment shall determine the most critical supporting construction on the basis of the tests carried out with the original construction material and respecting the conditions set out in (1) and (2).¹⁴

A.2.8 Limitation of size of optional flap or slide elements for closing of residual openings

- (1) Flap and slide elements triggered by a fusible link

The maximum dimensions for these additional elements shall be the dimensions tested in the fire resistance test; they shall be as small as possible (maximum clear width: 0,3 m; maximum clear height: 0,3 m; maximum clear area: 0,015 m²).

During this test, the duration and intensity of smoke penetration through the opening to be closed by the additional element shall be monitored before as well as after the additional element has been triggered. The results shall be recorded and assessed in the test report.

In case of excessive smoke penetration (by intensity or duration), a further test using additional elements with smaller dimensions and/or a different triggering behaviour shall be considered.

- (2) Sliding sealing element mechanically actuated when closing the sliding leaf

The dimensions of such additional elements may only be varied proportionally to the dimensions of the closure as a whole, so that the proportions tested positively during the fire resistance tests remain unchanged.

If these variations are admissible, shall be evaluated by the testing laboratory having carried out the fire resistance tests in an expert opinion. As it is assumed that the additional element closes safely only seconds after the closure itself, smoke penetration does not need to be given special consideration in this case.

¹⁴ The testing laboratory shall explain why the conditions chosen are to be considered as most critical. The explanation shall be recorded in the test report.

ANNEX B ADDITIONAL PROVISIONS FOR TESTING MECHANICAL DURABILITY OF SELF-CLOSING

B.1 Design of the test specimen

When designing the test specimen sealing blocks on the movable element used during the fire resistance tests shall be taken into account where applicable.

B.2 Tests for flaps with different orientations of hinges

The tests to be carried out for movable elements vary depending on whether the elements rotate vertically or horizontally.

- Tests for movable elements with vertically oriented hinges
 - vertical stress applied to the hinges
 - test specimens with maximum dimensions/maximum weight (use of additional weights is possible)
 - installation in a wall.
- Tests for movable elements with horizontally oriented hinges
 - horizontal stress applied to the hinges
 - test specimens with maximum dimensions/maximum weight (use of additional weights is possible)
 - installation in the most critical installed position (wall, on top of or below the floor); the testing laboratory shall determine the most critical installed position and install the test specimen accordingly for the test. The design calculations shall be recorded in the test report.

The biggest dimensions of the test specimen shall be determined giving due consideration to the field of direct application in accordance with Annex A.1.8. The testing laboratory shall specify the dimensions of the test specimen for the maximum area increase.¹⁵

B.3 Type with electromotive opening aid

If the movable element is to be equipped with an electromotive opening aid, the electromotive opening aid shall be used for opening the movable element throughout all test cycles of the durability test. The testing laboratory shall also assess the risk of the electromotive opening aid impeding the shutting of the closure.

If different drives from the same series are to be used to actuate different closure sizes, the most powerful one (in combination with the biggest closure) shall be tested. It may be possible to extend the results from this test to less powerful drives from the same series (expert opinion issued by the testing laboratory).

B.4 Type with electromotive opening and closing

B.4.1 Electrical safety

The manufacturer shall submit a declaration in accordance with Directive 2014/35/EU, considering the relevant standards for this product (EN 60335-1, EN 60335-2-103).

B.4.2 Electromagnetically compatibility

The manufacturer shall submit a declaration in accordance with Directive 2004/108/EU considering the relevant standards for this product (EN 61000-6-2, EN 61000-6-3, EN 61000-3-2, EN 61000-3-3).

B.4.3 Functional safety

B.4.3.1 Compatibility of the components

Carrying out of a compatibility test

¹⁵ The testing laboratory shall justify its decision concerning the dimensions of the test specimen. The justification shall be recorded in the test report.

- comparison of the operating conditions of the components based on the product-related technical data sheets provided by the manufacturer
- random tests for device combinations selected by the testing laboratory

B.4.3.2 Safety level of the whole system

The safety level provided shall be evaluated in terms of the "performance level" (pl) determined in accordance with EN ISO 13849-1 (including software testing)

B.4.3.3 Method of restoring operability after triggering

After a shutting process has been triggered, a functional test shall be carried out to ensure that the system is fully operational again.

B.4.3.4 Closing force or torque and closing velocity

The manufacturer shall provide information concerning the closing force or torque and the closing velocity in the operator's manual.

B.4.3.5 Behaviour in case of voltage fluctuations

The behaviour in case of voltage fluctuations shall be evaluated by means of a simulation of a voltage fluctuation of $\pm 10\%$ of the rated value.

B.4.3.6 Behaviour when no fire alarm has been triggered

- in the case of a power outage (longer than 2 s)
 - a) The method used to activate the second power supply (e.g. standby parallel operation) shall be identified (document check) and verified by means of a functional test.
 - b) The state of any opening systems shall be identified (document check) and verified by means of a functional test.
 - c) The time period between the detection of the malfunction and the initiation of the shutting process as well as the state of the safety system for monitoring the closing area shall be identified (document check) and verified by means of a functional test.
 - d) The behaviour in case of contact with an obstacle shall be identified (document check) and verified by means of a functional test. In this process, an energy design for the second power supply shall be developed, taking into account the specific conditions of the intended field of application.

The energy design shall ensure that

- if the batteries are at their lowest operational levels¹⁶ and
- the power supply has been stored at the lowest temperature for the intended use for 8 hours

the drive system triggers at least 5 attempts to close the movable element¹⁷ (complete opening and closing cycles¹⁸) within a time span of 30 min, when a fire alarm is triggered.

The battery voltage shall not fall below the cut-off voltage of the battery at any point. If the batteries reach their lowest operational levels, the movable element shall be triggered to shut.

After that, all essential components of the drive system shall be supplied with energy as needed until the system is shut down completely because the cut-off voltage is reached.

- in the case of a malfunction of the second power supply
 - a) The time period before a malfunction is detected and signalled and the type of signal (visual and/or acoustic) shall be identified (document check) and verified by means of a functional test.
 - b) The method and the time needed for checking the state of charge of the second power supply shall be identified (document check) and verified by means of a functional test.

¹⁶ The lowest operational level shall be a value situated between the operating voltage and the cut-off voltage of the battery, determined by the manufacturer of the control unit

¹⁷ The test shall be carried out with the maximum weight of the movable element and the maximum distance to be covered.

¹⁸ The middle speed of the relevant speed range shall be used.

- in the case of a malfunction of the drive system and the drive control unit
 - a) The time period before a malfunction is detected and signalled and the type of signal (visual and/or acoustic) shall be identified (document check) and verified by means of a functional test.
 - b) The state of any opening systems shall be identified (document check) and verified by means of a functional test.
 - c) The time period between the detection of the malfunction and the initiation of the shutting process and the state of the safety system for monitoring the closing area shall be identified (document check) and verified by means of a functional test.
 - d) The behaviour in case of contact with an obstacle shall be identified (document check) and verified by means of a functional test.
 - in case of a malfunction of an optional safety system for monitoring the closing area¹⁹ which remains active in the event of a fire
 - a) The time period before a malfunction is detected and signalled and the type of signal (visual and/or acoustic) shall be identified (document check) and verified by means of a functional test.
 - if the closing area is permanently blocked
 - a) The time period before the malfunction is detected and signalled and the type of signal (visual and/or acoustic) shall be identified (document check) and verified by means of a functional test.
 - b) If there is an adjustable set period²⁰ after which the shutting process is forced, the setting options shall be identified (e.g. several set periods or continuously adjustable set period within a defined range) (document check) and verified by means of a functional test.
- B.4.3.7 Behaviour when a fire alarm is triggered and there is no safety system for monitoring the closing area (adjustable set period²⁰ / enforced closing after adjusted period)**
- if the fire alarm is triggered by a local fire detector or the general fire alarm system or if the shutting process has been triggered manually
 - a) The time period before a malfunction is detected and signalled and the type of signal (visual and/or acoustic) shall be identified (document check) and verified by means of a functional test.
 - b) The state of any opening systems, smoke-sensitive optical safety systems and, if applicable, a fail-locked electric strike shall be identified (document check) and verified by means of a functional test.
 - c) The time period between the detection of the alarm and the initiation of the shutting process shall be identified (document check) and verified by means of a functional test.
 - d) The behaviour in case of contact with an obstacle shall be identified (document check) and verified by means of a functional test.
 - in the case of an additional mains power outage (longer than 2s) after the fire alarm has been triggered
 - a) The method used to activate the second power supply (e.g. standby parallel operation) shall be identified (document check) and verified by means of a functional test.
 - b) The behaviour in case of contact with an obstacle shall be identified (document check) and verified by means of a functional test.
- B.4.3.8 Behaviour when a fire alarm is triggered and there is a safety system for monitoring the closing area which remains active in the event of a fire**
- in the case that the fire alarm is triggered by a local fire detector or the general fire alarm system or if the shutting process has been triggered manually

¹⁹ For certain goods, monitoring the closing area is not possible (e.g. for dry bulk materials where there are no gaps in the material stream during normal operation). In this case, the movable element shall be shut after a determined period of time for clearing the conveyor system in the closing area.

²⁰ This period shall be determined in accordance with the national provisions.

- a) The time period before a malfunction is detected and signalled and the type of signal (visual and/or acoustic) shall be identified (document check) and verified by means of a functional test.
 - b) The state of any opening systems, smoke-sensitive optical safety systems and, if applicable, a fail-locked electric strike shall be identified (document check) and verified by means of a functional test.
 - c) The time period between the detection of an alarm and the initiation of the shutting process and the state of the safety system for monitoring the closing area which remains active in the event of a fire shall be identified (document check) and verified by means of a functional test.
 - d) The behaviour in case of contact with an obstacle shall be identified (document check) and verified by means of a functional test.
- In the case of an additional mains power outage (longer than 2s) after the fire alarm has been triggered
- a) The method used to activate the second power supply (e.g. standby parallel operating) shall be identified (document check) and verified by means of a functional test.
 - b) The behaviour in case of contact with an obstacle shall be identified (document check) and verified by means of a functional test.

B.4.4 Admissible fire detection devices

The manufacturer shall provide the declarations of performance for the fire detection devices used. These shall first be checked for compatibility with the system in accordance with clause B.4.3.1.

B.4.5 Admissible optical systems for monitoring the closing area which remain active in the event of a fire

If optical systems for monitoring the closing area (e.g. light barriers) are used, these shall be sufficiently insensitive to smoke. This shall be checked as follows:

- a) Determination of the response threshold value of the optical sensors based on EN 54-12 (4 test specimens per sensor type)
- b) The optical sensors shall be mounted at the same height than the control measurement devices. The distance between the transmitter and the receiver or the distance between the transmitter/receiver and the reflector during the tests shall be 10 m (shorter distances may be agreed upon, if appropriate).
- c) Determination of the sensitivity to fire based on EN 54-12, using the rated voltage; after a short functionality test (response to an opaque object in the light path), the optical sensors (3 out of the 4 test specimens per sensor type mentioned under point a) shall **not** respond when exposed to test fires TF2 to TF5 ($m = 2$ dB/m, or $y = 6$).
- d) Testing the sensitivity of the optical sensors to fluctuations in the power supply based on EN 54-12 (test of 1 of the 4 test specimens per sensor type mentioned under point a)