

EUROPEAN ASSESSMENT DOCUMENT

EAD 210020-00-0402

August 2018

**FACTORY MADE SELF-
SUPPORTING COMPOSITE
PUR/PIR FOAM INSULATED
METAL SHEET FOR ROOFING,
EXTERNAL CLADDING AND
INTERNAL LINING**

The reference title and language for this EAD is English. The applicable rules of copyright refer to the document elaborated in and published by EOTA.

This European Assessment Document (EAD) has been developed taking into account up-to-date technical and scientific knowledge at the time of issue and is published in accordance with the relevant provisions of Regulation (EU) No 305/2011 as a basis for the preparation and issuing of European Technical Assessments (ETA).

Contents

SCOPE OF THE EAD	3
1.1 Description of the construction products	3
1.2 Information on the intended uses of the construction product	3
1.2.1 Intended uses.....	3
1.2.2 Working life/Durability.....	4
1.3 Specific terms used in this EAD	4
1.3.1 Auto-adhesion	4
1.3.2 Fixing (fastener).....	4
1.3.3 Polyurethane foam (PUR).....	5
Rigid cellular plastics insulation material or product with a structure based on polymers mainly of the polyurethane type.....	5
1.3.4 Polyisocyanurate foam (PIR)	5
Rigid cellular plastics insulation material or product with a structure based on polymers mainly of the polyisocyanurate type.....	5
1.3.5 Self-supporting product	5
1.3.6 Side lap	5
1.3.7 Sinusoidal profiled sheet.....	5
1.3.8 Skin	5
1.3.9 Trapezoidal profiled sheet	5
2 Essential characteristics and relevant assessment methods and criteria	6
2.1 Essential characteristics of the product	6
2.2 Assessment methods and criteria for the performance of the products in relation to essential characteristics of the products	7
2.2.1 Reaction to fire.....	7
2.2.2 External fire performance (roofs)	7
2.2.3 Water permeability	7
2.2.4 Dimensional tolerances (geometrical properties).....	7
2.2.5 Water absorption (short term, partial immersion)	8
2.2.6 Water vapour permeability.....	8
2.2.7 Biological resistance	9
2.2.8 Mechanical resistance (wind and snow loads).....	9
2.2.9 Point load resistance (roofs)	9
2.2.10 Impact resistance (hard body and soft body)	10
2.2.11 Corrosion resistance.....	10
2.2.12 Thermal conductivity (PUR/PIR foam)	10
2.2.13 Air permeability.....	11
2.2.14 PUR/PIR layer thickness	11
2.2.15 Density (PUR/PIR foam)	11
3 ASSESSMENT AND VERIFICATION OF CONSTANCY OF PERFORMANCE	12
3.1 Systems of assessment and verification of constancy of performance to be applied	12
3.2 Tasks of the manufacturer	12
3.3 Tasks of the notified body	13
4 REFERENCE documents	15
Annex A REACTION TO FIRE TESTS	16

1. SCOPE OF THE EAD

1.1 Description of the construction products

The construction products consist of factory made self-supporting composite lightweight profiled (e.g. trapezoidal or sinusoidal) or tiled steel sheets covered in the internal side with a thin layer of PUR/PIR foam, either not faced or faced with an adherent embossed aluminum foil in the internal face. . The products are manufactured from steel sheets with a nominal thickness greater than 0.4 mm.

The auto adhesive rigid polyurethane (PUR) or polyisocyanurate (PIR) foam layer is factory applied as a dispensed or sprayed product with a thickness not exceeding 25 mm. This thin PUR layer is only intended to avoid or to minimize internal surface condensation.

The construction products are hereinafter referred to as self-supporting composite metal sheets.

The products are not fully covered by the harmonised standard: EN 14782:2006, since it doesn't fit in the definition of multilayer coated steel sheet given in its Annex A of this standard and EN 14782 doesn't consider requirements nor assessment methods concerning thermal insulation characteristics. On the other hand, the products are not fully covered by ETAG 016 since they are not composite panels with two skins and a core layer.

Concerning product packaging, transport, storage, maintenance, replacement and repair it is the responsibility of the manufacturer to undertake the appropriate measures and to advise his clients on the transport, storage, maintenance, replacement and repair of the products as he considers necessary.

It is assumed that the products will be installed according to the manufacturer's instructions or (in absence of such instructions) according to the usual practice of the building professionals.

Relevant manufacturer's stipulations having influence on the performance of the products covered by this European Assessment Document shall be considered for the determination of the performance and detailed in the ETA.

The EAD applies to the self-supporting composite metal sheets. All other ancillary components of the roofs, external wall claddings and internal linings, which are necessary to fix the composite sheets and seal the joints are not considered as part of the products covered by the EAD.

The self-supporting composite metal sheets are intended to be fixed, as those covered by EN 14782, to specific linear supporting elements made of steel, wood or concrete (not part of the building structure), by means of current fixings adequate to each type of support. Both supports and fixings are not part of the products.

1.2 Information on the intended uses of the construction product

1.2.1 Intended uses

The products have the following intended uses in new and renovated agricultural, industrial, services and residential buildings:

- Roofing (pitched roofs with pitch < 70° from the horizontal);
- External cladding and internal linings.

The PUR/PIR foam layer intends to provide thermal protection and to prevent internal surface moisture condensation and moisture dripping caused by condensation.

The optional embossed aluminium foil intends to provide additional water vapour resistance and to improve the reaction to fire performance of the products.

An additional internal protection/finishing layer, additional thermal insulation and/or water vapour barrier layers or complementary joint profiles may be required in some uses (not covered in the EAD).

The construction product is not intended to be used in habitable or occupable places where the PUR/PIR foam may be exposed to direct flame impingement or to frequent impacts.

The self-supporting composite lightweight profiled or tiled metal sheets are not intended for structural purposes nor have influence on the racking resistance of the works.

Roof surfaces are not accessible without protection and security assessment.

1.2.2 Working life/Durability

The assessment methods included or referred to in this EAD have been written based on an assumed working life of the self-supporting composite metal sheets for the intended use of 15 years, provided that the products are subject to appropriate installation, use and maintenance (see 1.1). These provisions are based upon the current state of the art and the available knowledge and experience.

When assessing the products, the intended use as foreseen by the manufacturer shall be taken into account. The real working life may be, in normal use conditions, considerably longer without major degradation affecting the basic requirements for works¹.

The indications given as to the working life of the construction products cannot be interpreted as a guarantee neither given by the manufacturer or his representative nor by EOTA when drafting this EAD nor by the Technical Assessment Body issuing an ETA based on this EAD, but are to be regarded only as a means for expressing the expected economically reasonable working life of the product.

1.3 Specific terms used in this EAD

1.3.1 Auto-adhesion

Self-adhesion of the PUR/PIR layer to the external metal sheet and to the (optional) internal facing foil occurring automatically without the use of an adhesive

1.3.2 Fixing (fastener)

A component intended to be used to fasten the self-supporting lightweight composite sheets to the substrate, support or supporting frame mechanically, that is usually made of a (metal) screw, possibly with a plastic or metal washer, etc.

¹ The real working life of a product incorporated in a specific works depends on the environmental conditions to which that works is subject, as well as on the particular conditions of the design, execution, use and maintenance of that works. Therefore, it cannot be excluded that in certain cases the real working life of the product may also be shorter than the working life referred to above.

1.3.3 Polyurethane foam (PUR)

Rigid cellular plastics insulation material or product with a structure based on polymers mainly of the polyurethane type

1.3.4 Polyisocyanurate foam (PIR)

Rigid cellular plastics insulation material or product with a structure based on polymers mainly of the polyisocyanurate type

1.3.5 Self-supporting product

Product which will, by virtue of its materials and shape supports all applied loadings (e.g. snow, wind, internal air pressure, foot traffic), and transmits these loadings to the supports

1.3.6 Side lap

Folded area along the longitudinal edge of the metal sheet which engages with the adjacent sheet to form an interlocking or overlapping joint

1.3.7 Sinusoidal profiled sheet

Self-supporting sheet which is designed to allow it to be side and end lapped, comprising a series of arc shaped crowns and valleys interconnected with tangential webs

1.3.8 Skin

Internal (optional) covering of the PUR/PIR layer made with embossed aluminum foil intended to improve the reaction to fire performance and/or to reduce the water vapour transmission through the PUR/PIR layer

1.3.9 Trapezoidal profiled sheet

Self-supporting sheet which is designed to allow it to be side and end lapped, the crowns of which may be rounded and, in addition, the crowns, webs and valleys may be stiffened

2 ESSENTIAL CHARACTERISTICS AND RELEVANT ASSESSMENT METHODS AND CRITERIA

2.1 Essential characteristics of the product

Table 1 shows how the performance of the self-supporting composite metal sheets for roofing, external cladding and internal lining are assessed in relation to the essential characteristics.

Table 1 Essential characteristics of the products and methods and criteria for the performance of the products in relation to those essential characteristics

No	Essential characteristic	Assessment method	Type of expression of product performance (<i>level, class, description</i>)
Basic Works Requirement 2: Safety in case of fire			
1	Reaction to fire	2.2.1	Class
2	External fire performance (roofs)	2.2.2	Class
Basic Works Requirement 3: Hygiene, health and the environment			
3	Water permeability	2.2.3	Description (<i>statement or criterion</i>)
4	Dimensional tolerances (geometrical properties) * <ul style="list-style-type: none"> - Length - Squareness - Design (cover) width - Deviation of side laps. - Thickness of external metal sheet - Thickness of internal aluminium foil facing - Thickness of PUR/PIR layer (see clause 2.2.14) - Thickness of composite sheet - Pitch - Depth of profile - Width of crown and valley - Depth of stiffeners 	2.2.4	Level
5	Water absorption of PUR/PIR foam (short term, partial immersion)	2.2.5	Level
6	Water vapour permeability	2.2.6	Level
7	Biological resistance (growth of mould fungus)	2.2.7	Level
Basic Works Requirement 4: Safety and accessibility in use			
8	Mechanical resistance (bending under wind and snow loads)	2.2.8	Description
9	Point load resistance (roofs)	2.2.9	Level
10	Impact resistance (hard body and soft body)	2.2.10	Description

No	Essential characteristic	Assessment method	Type of expression of product performance (level, class, description)
11	Corrosion resistance	2.2.11	Description
Basic Works Requirement 6: Energy economy and heat retention			
12	Thermal conductivity (PUR/PIR foam)	2.2.12	Level
13	Air permeability	2.2.13	Description (<i>statement or criterion</i>)
14	Insulation (PUR/PIR foam) thickness	2.2.14	Level
14	Insulation (PUR/PIR foam) density	2.2.15	Level

* These characteristics also relate to identification of the products, safety in use and thermal performance

2.2 Assessment methods and criteria for the performance of the products in relation to essential characteristics of the products

2.2.1 Reaction to fire

The self-supporting composite steel sheets shall be tested using the test methods EN ISO 11925-2 and EN 13823 which are relevant for the corresponding reaction to fire class, in order to be classified according to Commission Delegated Regulation (EU) 2016/364 and EN 13 501-1.

For the product specific arrangement of the specimens for the reaction to fire test according to EN ISO 11925-2 and EN 13823 and the direct field of application of the test results see Annex A of the EAD.

Note 1: When required, the performance of the product's propensity to undergo continuous smouldering shall be assessed in accordance with EN 16733. Due to the reaction to fire performance of the PUR/PIR insulation it is possible that the product ignites whilst the burner is being applied. If the conditions defined in section 8.6.1 of EN 16733 are verified the test method is considered not suitable for the evaluation of the product.

2.2.2 External fire performance (roofs)

The roof in which the self-supporting composite metal sheets (including any additional layers) are intended to be incorporated shall be evaluated and assessed using the test method(s) relevant for the corresponding external fire performance class, in order to be classified according to Commission Decision 2001/671/EC² as amended by Commission Decision 2005/823/EC³.

2.2.3 Water permeability

Self-supporting composite metal sheets covered by this EAD are metal faced (external face). In the sense of clause 4.4 of EN 14782, when correctly manufactured and if satisfying an appropriate visual inspection (*no holes as defects*) they may be deemed to be impermeable to water. The watertightness of the assembly is a function of its installation and is not covered by this EAD.

2.2.4 Dimensional tolerances (geometrical properties)

Geometry of the self-supporting composite metal sheets shall be measured (at least one test specimen) adopting the procedures defined clauses 4.2 and 4.7 of EN 14782.

² See Official Journal L235, 3.9.2001, p.20

³ See Official Journal L307, 25.11.2005, p.53

Where relevant, the following dimensional properties for self-supporting composite metal sheets (and for its components), including tolerances, shall be considered:

- Width
- Length
- Squareness
- Design (cover) width
- Deviation of side laps.
- Thickness of external metal sheet
- Thickness of internal aluminium foil facing
- Thickness of PUR/PIR layer (see clause 2.2.14)
- Thickness of composite sheet
- Pitch
- Depth of profile
- Width of crown and valley
- Depth of stiffeners

The ETA will give general geometric characteristics and tolerances indicated by the manufacturer.

2.2.5 Water absorption (short term, partial immersion)

The determination of the short-term water absorption by partial immersion of the PUR/PIR rigid foam layer shall be carried out according to EN 1609, clause 7.2.2, method A (drainage).

Test specimens of the PUR/PIR foam shall be flat with the same density of the foam used in the composite profiled products.

The water absorption level, W_{sp} , in kg/m² shall be calculated using steps of 1 kg/m².

2.2.6 Water vapour permeability

Vapour permeability is relevant for the PUR/PIR layer, including any internal facings or coatings. The vapour tightness of the assembly is a function of its design, joints, fixings and installation and is not covered by the EAD.

The determination of the water vapour transmission properties of the PUR/PIR layer, including internal facings or coatings, shall be carried out according to EN 12086, clause 7.1, Table 1, set A and/or set C.

For hygroscopic products the result depends on the set of conditions and it is recommended to use both sets A and C.

The results of the test shall be expressed as the water vapour diffusion resistance factor (μ) for non-faced PUR/PIR foam and as the water vapour resistance (Z) for internally faced PUR/PIR foam layer.

The test atmospheres (set A and/or set C) according to EN 12086 used for testing shall be given in the ETA.

The dimensionless water vapour diffusion resistance factor, μ , of the PUR/PIR layer and the water vapour resistance, Z expressed in (m².h.Pa)/mg, of a faced PUR/PIR layer shall be stated in the ETA.

2.2.7 Biological resistance

The risk of biological growth and biological resistance shall be assessed by engineering judgement based on the existing knowledge of the product component materials (steel sheets, aluminium foil, PUR/PIR foam insulation) and the environmental conditions prevailing in the envisaged end uses.

The visual assessment of fungal growth in an exposed PUR/PIR surface shall be carried out according to method A of EN ISO 846. Test specimens shall have 20 mm to 60 mm linear dimensions, either square or rectangular shaped, compatible with the geometry of the composite steel sheet profile. However, a test thickness between 0.5 mm and 2 mm is recommended.

The growth of mould fungus shall be expressed according to Table 4 of EN ISO 846.

2.2.8 Mechanical resistance (wind and snow loads)

Self-supporting composite metal sheets are non-loadbearing parts of the work, and therefore mechanical resistance is considered under ER4 Safety in use

The panel shall be assessed for adequate resistance to relevant actions due to self-weight loads, wind loads and snow loads.

Point load resistance (roofs) and impact resistance are dealt with in clauses 2.2.9 and 2.2.10.

Mechanical resistance performance shall be verified either by testing or by calculation.

The test procedures in general shall follow and/or adapt, if necessary, relevant EN-standards or EOTA test methods for testing of specific types of panels.

The evaluation of the composite profiled steel sheets performed under the scope of the present EAD shall be based in the procedures defined in Annex C, Clauses C1 (positive load) and C2 (negative load) of ETAG 016-part 1, considering the following parameters:

- direction of load: positive or negative, representing actions due to self-weight loads, wind loads and snow loads;
- static configuration: one and two spans, or particular configuration defined by the producer;
- thickness and material properties of metal face(s) and PUR/PIR layer.

The tests shall embrace the extreme values of all parameters.

The tests are performed at normal laboratory conditions.

For the evaluation of the mechanical bending resistance at least three specimens for each test case should be tested. It is permissible to use quadratic interpolation between test results.

The corresponding characteristic values of the mechanical bending resistance shall be calculated according to ISO 12491 for $p=95\%$ (5% lower fractile), with a confidence level of 75 %.

The obtained results shall be checked against the type testing and factory production control of the materials and finished products.

Ultimate loads and serviceability states (load for conventional deflection values) shall be given in the ETA.

2.2.9 Point load resistance (roofs)

The resistance (without permanent deformations) of the self-supporting composite metal sheets with respect to a single person walking on the panel, for occasional access both during and after construction (maintenance) shall be evaluated using the procedure defined in EN 14782, Annex B (Determination of resistance to concentrated forces).

The test shall be carried out at least on a single profiled sheet of full width. The tested span shall be the largest quoted as suitable for use on a roof by the manufacturer. The load shall be applied at mid-span near the centre line of the test sheet.

Self-supporting composite sheets shall resist a concentrated force of 1.2 kN specified in Table 3 of EN 14782,

Note 1 Where the tested composite sheet fails to resist the concentrated force of 1.2 kN, another sheet should be retested at reduced span length.

Products intended for use at a span less than or equal to 400 mm, e.g. some tile profiles, are deemed to satisfy this requirement without the need for testing.

Note 1 In this case, the support structure will determine the resistance to imposed forces.

Note 2 Roof and ceiling self-supporting composite metal sheets are generally unsuitable for regular foot traffic.

Note 3 Self-supporting composite metal sheets should be protected when used on regular walking routes or working areas both during installation and in end use. Roofs should allow a wide and safe support for a foot and should not be subjected to permanent deformations under occasional foot traffic for access or maintenance. For maintenance purposes, only one person at a time should be allowed to walk on a composite sheet.

The result of the test, including any possible damage, shall be stated in the ETA.

2.2.10 Impact resistance (hard body and soft body)

The impact resistance of the self-supporting composite metal sheets due to dynamic loads from objects or persons who accidentally fall upon or against them shall be evaluated using the methods defined in EOTA Technical Report TR 001.

If various (either soft or hard body) impact energies are being applied, new test assemblies should be used for each level of impact.

The soft body impact resistance test shall be carried out on one test assembly and consists of one impact in the centre of the panel.

The hard body impact test shall be carried out on one test assembly and consists of one impact.

Both hard body impactors described in EOTA TR 001 – 1 kg steel ball (for safety in use assessment) and 0.5 kg steel ball (for serviceability assessment) – shall be used (in different test assemblies).

The criteria for the evaluation as specified in the EOTA TR 01 shall be taken into account.

The impact energies and evaluation results, including a description of damage, shall be stated in the ETA.

2.2.11 Corrosion resistance

The ETA shall state the type, thickness and grade of metal and, if appropriate, type and thickness (or mass) and/or category of any coating(s) based in the relevant information supplied by the manufacturer.

2.2.12 Thermal conductivity (PUR/PIR foam)

The initial PUR/PIR foam layer thermal conductivity at a temperature of 10 °C shall be determined according to EN 12667, following the general procedures defined in EN 13165.

At least 4 measurements shall be performed under dry conditions.

The PUR/PIR aged thermal conductivity shall be determined according the procedures defined in Annex C of EN 13165.

For products with uniform thickness the initial and aged thermal resistances shall be stated. Where appropriate, for products with non-uniform thickness the initial and aged thermal conductivities shall be indicated.

Note 1 If relevant the correction factors due to the influence of moisture and temperature can be calculated using the procedures given in EN ISO 10456.

2.2.13 Air permeability

Self-supporting composite metal sheets covered by this EAD are metal faced (external face). In the sense of clause 4.5 of EN 14782, when correctly manufactured and if satisfying an appropriate visual inspection (*no holes as defects*) they may be deemed to be impermeable to air (airtight). The watertightness of the assembly is a function of its installation and is not covered by this EAD.

2.2.14 PUR/PIR layer thickness

The thickness of the PUR/PIR rigid foam layer shall be determined in accordance with the procedure defined in the Annex B (clause B.1 – Pin-and-plate method) of EN 823.

The plate may be eliminated and replaced by a procedure that ensures that the measuring pin device is forced into the PUR/PIR layer perpendicular to its surface.

The locations of the measuring points are, in principle, those defined in EN 823 (clause 7.2, Figure 2). By visual judgment other points may be selected in order to obtain representative measures (*e.g.* different layer thickness, crown, valley and web points)

At least three full size self-supporting composite metal sheets shall be subjected to PUR/PIR layer thickness measurement.

The average PUR/PIR layer thickness shall not deviate from the nominal value more than ± 2.0 mm.

Thickness(es) mean value(s) and tolerance(s) shall be stated in the ETA.

2.2.15 Density (PUR/PIR foam)

The density of the PUR/PIR layer shall be determined in accordance the procedure defined in Annex C (immersion method) of EN 14320-2.

At least three test specimens with a minimum weight of 10 g shall be tested.

The mean density value shall be rounded to the nearest kg/m^3 .

The ETA will give the nominal mean density and corresponding tolerance indicated by the manufacturer.

3 ASSESSMENT AND VERIFICATION OF CONSTANCY OF PERFORMANCE

3.1 Systems of assessment and verification of constancy of performance to be applied

For the products covered by this EAD the applicable European legal act is: decision 98/436/EC as amended by 2001/596/EC.

The systems to be applied are 4; 3 (external fire performance)

In addition, with regard to reaction to fire for products covered by this EAD the applicable systems are 1, 3 and 4.

3.2 Tasks of the manufacturer

The corner stones of the actions to be undertaken by the manufacturer of the products in the procedure of assessment and verification of constancy of performance are laid down in Table 2.

Table 2 Control plan for the manufacturer; corner stones

No	Subject/type of control	Test or control method	Criteria, if any	Minimum number of samples	Minimum frequency of control*
Factory production control (FPC) [including testing of samples taken at the factory in accordance with a prescribed test plan]					
1	Raw and base materials	According to manufacturer's specifications	Control Plan	Control Plan	Each batch
2	Reaction to fire	2.2.1	Control Plan	2 (EN 13823) 6 (EN ISO 11925-1)	1 per year
3	External fire performance (roofs)	2.2.2	Control Plan	1	1 per 5 years
4	Water permeability	2.2.3	Control Plan	-	Continuous
5	Dimensional tolerances (geometrical properties)	2.2.4	Visual inspection (Clause 4.4 of EN 14782)	1	Clause 6.3 of EN 14782 (tables 4 and 5)
6	Water absorption (short term, partial immersion)	2.2.5	Control Plan (clauses 4.2 and 4.7 of EN 14782)	1	1 per year
7	Water vapour permeability	2.2.6	Control Plan	4	1 per year
8	Biological resistance	2.2.7	Control Plan	3	Control Plan

9	Mechanical resistance	2.2.8	Control Plan	1	Clause 6.3 of EN 14782 (tables 4 and 5)
10	Point load resistance	2.2.9	Control Plan	1	1 per year Clause 6.3 of EN 14782 (tables 4 and 5)
11	Impact resistance	2.2.10	Control Plan	1	Control Plan
12	Corrosion resistance	2.2.11	Control Plan	Control Plan	Control Plan
13	Thermal conductivity (PUR/PIR)	2.2.12	Control Plan	3	Every three months
14	Air permeability	2.2.13	Control Plan	-	Continuous
15	PUR/PIR thickness	2.2.14	Visual inspection (Clause 4.4 of EN 14782)	3	1 per day
16	Density (PUR/PIR foam)	2.2.15	Control Plan	Control Plan	1 per day

* In case of discontinuous production these minimum frequencies should be adapted to an equivalent frequency.

3.3 Tasks of the notified body

The cornerstones of the actions to be undertaken by the notified body in the procedure of assessment and verification of constancy of performance for the Factory made self-supporting composite PUR/PIR foam insulated metal sheet for roofing, external cladding and internal lining are laid down in Table 3.

The involvement of a notified product certification body is required only under the conditions defined in Decision 1999/94/EC as amended by Decision 2012/202/EC, in case of reaction to fire classes A1, A2, B and C of the product for which a clearly identifiable stage in the production process results in an improvement of the reaction to fire classification (e.g. a limiting of organic material and/or the addition of fire retardant).

Table 3 Control plan for the notified body; corner stones

No	Subject/type of control	Test or control method	Criteria, if any	Minimum number of samples	Minimum frequency of control
----	-------------------------	------------------------	------------------	---------------------------	------------------------------

Initial inspection of the manufacturing plant and of factory production control <i>(for system 1 only)</i>					
1	(for system 1 only) Control of the manufacturing plant and of the factory production carried out by the manufacturer regarding the constancy of performance related to reaction to fire and taking into account a limiting of organic material and/or the addition of fire retardant	2.2.1	Control Plan		When starting the production process, after its modification and when starting a new production line
Continuous surveillance, assessment and evaluation of factory production control <i>(for system 1 only)</i>					
2	(for system 1 only) Continuous surveillance, assessment and evaluation of the factory production control carried out by the manufacturer regarding the constancy of performance related to reaction to fire and taking into account a limiting of organic material and/or the addition of fire retardant	2.2.1	Control Plan		Annually

For the products falling under systems 3 or 4 (see clause 3.1), there is no involvement of a notified body after the ETA has been issued.

4 REFERENCE DOCUMENTS

As far as no edition date is given in the list of standards thereafter, the standard in its current version at the time of issuing the European Technical Assessment is of relevance.

EN 823	<i>Thermal insulating products for building applications - Determination of thickness</i>
EN 1609	<i>Thermal insulating products for building applications – Determination of short term water absorption by partial immersion</i>
EN 12086	<i>Thermal insulating products for building applications – Determination of water vapour transmission properties</i>
EN 12667	<i>Thermal performance of building materials and products – Determination of thermal resistance by means of guarded hot plate and heat flow meter methods – Products of high and medium thermal resistance</i>
EN 13165	<i>Thermal insulation products for buildings - Factory made rigid polyurethane foam (PU) products - Specification.</i>
EN 13238	<i>Reaction to fire tests for building products - Conditioning procedures and general rules for selection of substrates</i>
EN 13501-1	<i>Fire classification of construction products and building elements – Part 1: Classification using test data from reaction to fire tests</i>
EN 13823	<i>Reaction to fire tests for building products - Building products excluding floorings exposed to the thermal attack by a single burning item</i>
EN 14320-2	<i>Thermal insulating products for building equipment and industrial installations - In-situ formed sprayed rigid polyurethane (PUR) and polyisocyanurate foam (PIR) products - Part 2: Specification for the installed insulation products</i>
EN 14782	<i>Self-supporting metal sheet for roofing, external cladding and internal lining - Product specification and requirements</i>
EN 16733	<i>Reaction to fire tests for building products - Determination of a building product's propensity to undergo continuous smouldering</i>
EN ISO 846	<i>Plastics – Evaluation of the action of microorganisms</i>
EN ISO 10456	<i>Building materials and products – Hygrothermal properties – Tabulated design values and procedures for determining declared and design thermal values</i>
EN ISO 11925-2	<i>Reaction to fire tests – Ignitability of products subjected to direct impingement of flame – Part 2: Single-flame source test</i>
ISO 12491	<i>Statistical methods for quality control of building materials and components</i>
CDR (EU) 2016/364	<i>Commission Delegated Regulation (EU) 2016/364 of 1 July 2015 on the classification of the reaction to fire performance of construction products pursuant to Regulation (EU) No 305/2011 of the European Parliament and of the Council</i>
ETAG 016 - Part 1	<i>Guideline for European Technical Approval of self-supporting composite lightweight panels. Part 1: General</i>
EOTA TR 001	<i>Determination of impact resistance of panels and panel assemblies</i>

ANNEX A REACTION TO FIRE TESTS

A.1 Product and installation parameters

Test specimens shall be conditioned in accordance with EN 13238.

Tables A.1 and A.2 give the parameters that shall be taken into account when determining a product's reaction to fire performance and the field of application of the test results.

Table A.1– Product parameters

Product parameter		EN ISO 11925-2 EN 13823
PUR/PIR insulation layer	Type of product	X (valid for the same chemical system and blowing agent)
	Thickness	X
	Density	X
External steel sheet coating	Type and thickness	X
Aluminium internal facing	Thickness and perforations	X

Note Ageing procedures are not applicable for the test specimens

Table A.2 – Installation parameters

Installation parameter	EN ISO 11925-2	EN 13823
Exposure to thermal attack (surface and edge)	X	(surface only)
Substrate	—	—
Air gaps/cavities	—	X
Joints/edges	—	X
Size and positioning of test specimen	—	X
Product orientation and geometry	—	X
Fixing of the test specimen	—	X

A.2 Test arrangement for reaction to fire test according to EN ISO 11925-2 (Ignitability test)

Test shall be carried out with specimens of the lowest and highest nominal insulation (PUR/PIR) density. The test results are valid for the whole range of densities between those evaluated.

Test shall be carried out with specimens of the lowest and highest nominal insulation (PUR/PIR) thickness.

Where the thickness of the insulation layer is greater than 60 mm the test shall be carried out on specimens with an insulation layer of 60 mm and the result is valid for greater thicknesses.

The flame shall be applied to both the end (cut edge) and the surface of the test specimen. Besides the edge and surface exposures another set of test specimens shall be carried out with the specimen turned at 90 ° as specified in clause 7.3.3.2.3 of EN ISO 11925-2.

Where relevant both external and internal product surfaces/edges must be exposed to the flame attack. Different sets of test specimens have to be used for each exposure condition.

Preferably the test should be carried out in essentially flat specimens (see clause 3.3 of EN ISO 11925-1). If the tests are carried out over not essentially flat products the recommendations of clause 7.3.4 of EN ISO 11925-1 should be followed.

A.3 Test arrangement for reaction to fire test according to EN ISO 13823 (SBI test)

A.3.1 General

The test is carried out according the procedure defined in EN 13823 although some adaptations must be introduced to the mounting and fixing rules due to the particular geometry of the profiled self-supporting composite sheets.

The test specimens consist of two vertical wings forming a right-angled corner.

The assembly and the corner detail shall be as close as possible to the end use conditions specified by the manufacturer.

The self-supporting composite metal sheets, independently of their intended uses (see clause 1.2.1 of the EAD), shall be tested vertically in the SBI test trolley with a vertical overlap joint on the long wing.

The exposed dimensions of the specimens shall be as follows (see Figure A.1):

- Long wing: (1000 ± 5) mm x 1.5 m ± 5 mm (height)
- Short wing: (500 ± 5) mm x 1.5 m ± 5 mm (height)

The long wing shall be made up of two sheets in a way that the center of the vertical overlapping joint is 200 mm distant from the corner (see Figure A.1).

In cases where the profile depth in the face to be tested is greater than 10 mm, the facing shall be cut at the top and at the bottom to extend over the U profile (see Figure A.2). The cut bottom of the test specimen shall not extend over the burner (see Figure A.2)

The cut section shall be covered with a Z section flashing (see Figure A.2) of the same material of the steel sheet.

A minimum of 80 mm ventilated air space shall be created between standard backing board and back face of the composite sheet specimen.

The ventilated air space may be reduced down to 40 mm in case the composite sheet in its end use is applied close to another constructive (non combustible) wall or roof element creating an air space.

Depending on the requirements of the manufacturer the self-supporting composite sheets shall be tested with the external and/or the internal face subjected to the flame of the ignition source.

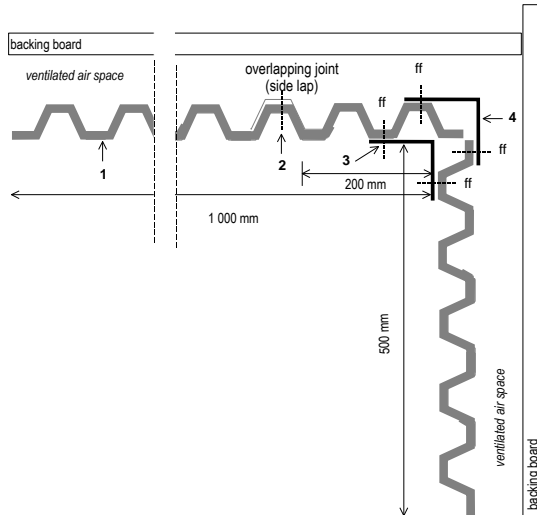

Key

- 1 - Self-supporting composite metal sheet test specimen (*example*: trapezoidal profile)
- 2 - Composite sheet overlapping joint fixing (*e.g.* rivets, screws)
- 3 - Internal corner flashing
- 4 - External corner flashing
- ff - Corner flashing fixings (*e.g.* rivets, screws)

Figure A.1 – Generic assembly and corner details of the SBI test specimen (horizontal cross section)

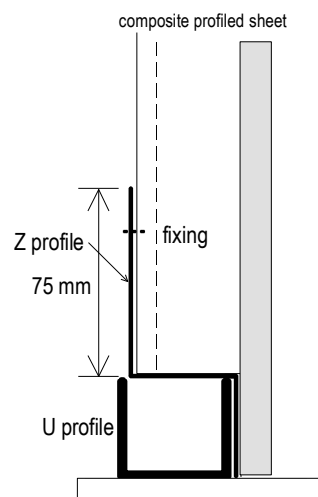

Figure A.2 – Cut-back of profiled composite sheet over U-profile

A.3.2 Securing the overlap vertical joint

The following principles shall apply when securing the sheets on the long wing:

- The overlap length and geometry between the two sheets along the vertical joint shall be as in the end use application;
- Sheets are in end used conditions, *i.e.* fixed by using rivets or screw fixings to hold the joint in place;
- The overlapping joint shall be secured by fixings starting at a minimum distance of 50 mm from the top and bottom of the specimen and spaced not more than 400 mm.

Note Appropriate spacing from the bottom are either 50 mm, 450 mm, 850 mm, 1250 mm and 1450 mm, or 50 mm, 250 mm, 650 mm, 1050 mm and 1450 mm

A.3.3 Securing the corner joint

At the corner joint the two wings shall be secured at 90° using internal and external corner flashings (see Figure A.1) fixed with “pop” rivets or screws spaced 400 mm.

As a reference, the corner flashings shall have the following dimensions:

- Internal flashing: 50 x 50 mm x 0.5 mm thickness;
- External flashing: 50 x [$t+50$] mm x 0.5 mm thickness, where t is the full thickness (depth of profile + insulation thickness) of the composite profiled sheet.

The internal corner flashing shall have the same coating as the panel specimen;

The cut panel edges at the top and sides of the specimen shall not be covered by flashings, foil or other materials.

When required for specific profiled sheets or end use applications alternative corner flashings (material, geometry) may be used.

Products without corner flashings in end use shall be tested without corner flashings.

A full description of the adopted flashings and fixing procedure shall be stated in the test report

A.3.4 Direct field of application with respect to the Single Burning Item (EN13823)

The reaction to fire classification is only valid for the method of installation tested in the SBI.

The field of application in the clauses A.3.4.1 to A.3.4.4 covers self-supporting composite sheets of the same family *i.e.* which have the same:

- thickness and profile of external facing steel sheet;
- thickness and characteristics of internal facing;
- type and thickness of coating (different colours are deemed to have the same properties);
- design of panel to panel joint;
- characteristics of insulation material (PUR/PIR);
- no additional combustible layers (*e.g.* insulation or water vapour barriers) installed in end use application.

Note Where the self-supporting composite steel sheets are used together with additional thermal and/or acoustic insulation or other functional layers, the full assembly shall be tested together with these additional products under end use conditions, as far as possible.

A.3.4.1 Thickness

Where composite sheets of the same family are produced of different thickness (or with different component thicknesses) the maximum and minimum thickness shall be tested.

Different classifications may be attributed relating to different thickness of the product/components

A.3.4.2 Density

Where composite sheets of the same family are produced with PUR/PIR insulation layer of different densities the maximum and minimum density shall be tested.

Different classifications may be attributed relating to different density of the PUR/PIR layer

A.3.4.3 External steel sheet coating

Different type (composition) and thickness of the external sheet coating may influence the reaction to fire classification and shall be tested separately (different colours are deemed to have the same classification).

A.3.4.4 Aluminium internal facing

The thickness of the aluminium foil and eventual (intentional) regular or random perforations of its surface may influence the reaction to fire classification. Tests shall be carried separately to accommodate the expected alternatives.