



## EUROPEAN ASSESSMENT DOCUMENT

EAD 210024-00-0504

January 2018

# CEMENT-BONDED BOARD

The reference title and language for this EAD is English. The applicable rules of copyright refer to the document elaborated in and published by EOTA.

This European Assessment Document (EAD) has been developed taking into account up-to-date technical and scientific knowledge at the time of issue and is published in accordance with the relevant provisions of Regulation No (EU) 305/2011 as a basis for the preparation and issuing of European Technical Assessments (ETA).

## Contents

<b>1</b>	<b>Scope of the EAD</b>	<b>5</b>
1.1	Description of the construction product	5
1.2	Information on the intended use(s) of the construction product	6
1.2.1	Intended use(s)	6
1.2.2	Working life/Durability	7
1.3	Specific terms used in this EAD (if necessary in addition to the definitions in CPR, Art 2)	7
<b>2</b>	<b>Essential characteristics and relevant assessment methods and criteria</b>	<b>9</b>
2.1	Essential characteristics of the product	9
2.2	Methods and criteria for assessing the performance of the product in relation to essential characteristics of the product	10
2.2.1	Thickness	10
2.2.2	Dimension (Length and width)	10
2.2.3	Straightness of edges	11
2.2.4	Squareness of edges	11
2.2.5	Density	11
2.2.6	Moisture content	11
2.2.7	Water impermeability (only for outdoor applications)	11
2.2.8	Dimensional stability	12
2.2.9	Modification factor	12
2.2.10	Deformation factor	12
2.2.11	Bending strength and bending modulus of elasticity	12
2.2.12	Tensile strength and tensile modulus of elasticity in plane of the board	12
2.2.13	Compressive strength and compressive modulus of elasticity	13
2.2.14	Shear strength and shear modulus in the plane of the board	13
2.2.15	Shear strength and shear modulus perpendicular to the plane of the board	14
2.2.16	Embedment strength	14
2.2.17	Pull through resistance	15
2.2.18	Influence of the edge distance of the fasteners on the embedment strength and slip modulus of the fastener	15
2.2.19	Racking resistance	16
2.2.20	Impact resistance	16
2.2.21	Water absorption	16
2.2.22	Freeze-thaw resistance	17
2.2.23	Heat-rain resistance	18
2.2.24	Warm water resistance	18
2.2.25	Soak-dry resistance	19
2.2.26	Durability	19
2.2.27	Reaction to fire	20
2.2.28	Vapour permeability	20
2.2.29	Content, emission and/or release of dangerous substances	20
2.2.30	Thermal conductivity	21
2.2.31	Air permeability	21
<b>3</b>	<b>Assessment and verification of constancy of performance</b>	<b>22</b>
3.1	Systems of assessment and verification of constancy of performance to be applied	22
3.2	Tasks of the manufacturer	22
3.3	Tasks of the notified body	23
<b>4</b>	<b>Reference documents</b>	<b>24</b>

<b>Annex A - Evaluation of the influence of moisture and load duration.....</b>	<b>26</b>
<b>Annex B - Determination of bending strength, bending modulus of elasticity perpendicular to the plane and in plane to the plane of the board and type of bending behaviour perpendicular to the plane of the board .....</b>	<b>29</b>
<b>Annex C - Reaction to fire – Mounting and fixing conditions for testing according to EN 13823 ...</b>	<b>34</b>

# 1 SCOPE OF THE EAD

## 1.1 Description of the construction product

The "Cement-bonded board" is a specific board made of cement acc. to EN 197-1 or a calcium silicate formed by a chemical reaction of a siliceous and a calcareous material reinforced by coated glass fibres (in form of glass fibre meshes or chopped glass fibres). Alternatively the coated glass fibre mesh can be replaced by fibre reinforcement (man-made fibres or wood fibres).

If glass fibre mesh reinforcement is used it shall enclose the complete front and back of the board.

The reinforcing fibres shall be one or more of the following forms:

- discrete elements randomly dispersed (chopped glass fibres);
- continuous strands or tapes;
- nets or webs.

Process aids, fillers, aggregates and pigments may be added.

The boards are not made with the Hatschek procedure.

This EAD covers cement-bonded board of type NT (Non-asbestos Technology).

The exposed face of the "Cement-bonded board" shall be without texture. The board can be coated with an adherent surface coating (hydrophobic agent) to prevent absorption of humidity during the installation (construction phase).

This EAD is not valid for "Cement-bonded boards" which contain used wood, man-made mineral fibres or ceramic fibres EU 1A/1B.

The thickness of the cement-bonded board amounts to a minimum of 6 mm and a maximum of 30 mm.

For structural applications the recommended thickness of the boards shall be at least 8 mm.

The minimum width is 600 mm and the minimum length 900 mm.

This EAD covers cement bonded board with a minimum modulus of rupture (MOR) for the bending strength perpendicular to the plane according to EN 12467, clause 5.4.4, of 2 MPa and a minimum density of 625 kg/m<sup>3</sup>.

The boards may be supplied with holes for fixing and/or cut to size.

The kit consists on the following components: the "Cement-bonded board" and the fasteners for the "Cement-bonded board".

The "Cement-bonded board" is not fully covered by the harmonised standard hEN 12467. For the intended use of the "Cement-bonded board" following additional specifications are required:

- Moisture content (H)
- Dimensional stability ( $\delta l_{65,85}$ ,  $\delta l_{65,30}$ )
- Modification factor ( $k_{mod}$ )
- Deformation factor ( $k_{def}$ )
- Characteristic bending strength ( $f_{m,0,k}$ ;  $f_{m,90,k}$ )
- Mean value of the bending modulus of elasticity ( $E_{m,0,mean}$ ;  $E_{m,90,mean}$ )
- Characteristic tensile strength ( $f_{t,0,k}$ ;  $f_{t,90,k}$ )
- Mean value of the tensile modulus of elasticity in the plane of the board ( $E_{t,0,mean}$ ;  $E_{t,90,mean}$ )
- Characteristic compressive strength ( $f_{c,0,k}$ ;  $f_{c,90,k}$ )
- Mean value of the compressive modulus of elasticity ( $E_{c,0,mean}$ ;  $E_{c,90,mean}$ )
- Characteristic shear strength in the plane of the board ( $f_{r,0,k}$ ;  $f_{r,90,k}$ )
- Mean value of the shear modulus in the plane of the board ( $G_{r,0,mean}$ ;  $G_{r,90,mean}$ )
- Characteristic shear strength perpendicular to the plane of the board ( $f_{v,0,k}$ ;  $f_{v,90,k}$ )
- Mean value of the shear modulus perpendicular to the plane of the board ( $G_{v,0,mean}$ ;  $G_{v,90,mean}$ )
- Embedment Strength ( $f_{h,0,k}$ ;  $f_{h,90,k}$ )
- Pull through resistance ( $f_{head,\alpha,k}$ )

- Influence of the edge distance of the fasteners on the embedment strength and slip modulus of the fastener ( $K_{ser}$ )
- Racking resistance ( $F_{i,v,Rd}$ )
- Impact Resistance (IR)
- Vapour permeability ( $\mu$ )
- Thermal conductivity ( $\lambda$ )

Concerning product packaging, transport, storage, maintenance, replacement and repair it is the responsibility of the manufacturer to undertake the appropriate measures and to advise his clients on the transport, storage, maintenance, replacement and repair of the product as he considers necessary.

It is assumed that the product will be installed according to the manufacturer's instructions or (in absence of such instructions) according to the usual practice of the building professionals.

Relevant manufacturer's stipulations having influence on the performance of the product covered by this European Assessment Document shall be considered for the determination of the performance and detailed in the ETA.

Note: The "Cement-bonded board" will be named as "Product".

## 1.2 Information on the intended use(s) of the construction product

### 1.2.1 Intended use(s)

The "Product" may be used for non-structural internal and external walls, as lining, and for the manufacture of floor construction elements and also for structural applications for the planking and lining of walls, for stiffening timber or steel framed walls, ceilings and roof truss structures.

The field of application of the "Product" used for structural applications are the service classes<sup>1</sup> 1 and 2 according to EN 1995-1-1 and the service class 3 according to EN 1995-1-1 but without outdoor exposure. The field of application of the "Product" used for non-structural applications are the service classes<sup>1</sup> 1, 2 and 3 without restrictions.

Subject to the intended uses the "Product" may be divided into following categories / classes:

Category <b>A</b> acc. to EN 12467:	"Product" which are for applications where they may be subjected to heat, high moisture and severe frost.
Category <b>B</b> acc. to EN 12467:	"Product" which are intended for applications where they may be subjected to heat, moisture and occasional frost, e.g. where they are either protected from or not subjected to severe weathering conditions.
Category <b>C</b> acc. to EN 12467:	"Product" which are intended for internal applications, where they may be subjected to heat and moisture, but not to frost.
Category <b>D</b> acc. to EN 12467:	"Product" for rigid underlayer applications.
Service class <b>1</b> acc. to EN 1995-1-1:	Is characterised by a moisture content in the materials corresponding to a temperature of 20 °C and the relative humidity of the surrounding air only exceeding 65 % for a few weeks per year.
Service class <b>2</b> acc. to EN 1995-1-1:	Is characterised by a moisture content in the materials corresponding to a temperature of 20 °C and the relative humidity of the surrounding air only exceeding 85 % for a few weeks per year.
Service class <b>3</b> acc. to EN 1995-1-1:	Is characterised by climatic conditions leading to higher moisture contents than in service class 2.

<sup>1</sup> Since the mechanical properties of timber are mainly influenced by the moisture content the service classes 1 to 3 in EN 1995-1-1 take care only of this property. The mechanical properties of "Cement-bonded board" are additionally influenced if they are exposed to heat and frost. Therefore the classes A, B, C and D of EN 12467 are used for the classification of the "Cement-bonded boards". Considering only the aspect of moisture one can suppose that the categories A and B are equal to service class 3 and category C is equal to service class 3 without outdoor exposure

Class <b>X1</b> :	"Product" which is intended for applications like indoor swimming pool and shower room.
Class <b>X2</b> :	Boards which are intended for applications like sauna.
Class <b>Y</b> :	Boards which are intended for other applications

### 1.2.2 Working life/Durability

The assessment methods included or referred to in this EAD have been written based on the manufacturer's request to take into account a working life of the "Product" for the intended use of 50 years when installed in the works provided that the "Product" is subject to appropriate installation (see 1.1). These provisions are based upon the current state of the art and the available knowledge and experience.

When assessing the product, the intended use as foreseen by the manufacturer shall be taken into account. The real working life may be, in normal use conditions, considerably longer without major degradation affecting the basic requirements for works<sup>2</sup>.

The indications given as to the working life of the construction product cannot be interpreted as a guarantee neither given by the product manufacturer or his representative nor by EOTA when drafting this EAD nor by the Technical Assessment Body issuing an ETA based on this EAD, but are regarded only as a means for expressing the expected economically reasonable working life of the product.

### 1.3 Specific terms used in this EAD (if necessary in addition to the definitions in CPR, Art 2)

The notations and symbols frequently used in this EAD are given below. Further particular notation and symbols are given in the text.

#### Symbols

a	=	length (l) and width (w) of the board
sqe	=	squareness of edges of the board
ste	=	straightness of the edges of the board
e	=	thickness of the board
t <sub>nom</sub>	=	nominal value of thickness

#### Base materials

$\alpha$	=	thermal coefficient of the board
$\rho$	=	density of the board
$\rho_m$	=	mean value of density
$E_{c,0,mean}$	=	compressive modulus of elasticity in the plane of the board
$E_{c,90,mean}$	=	compressive modulus of elasticity perpendicular to the plane of the board
$E_{m,0,mean}$	=	bending modulus of elasticity in the plane of the board
$E_{m,90,mean}$	=	bending modulus of elasticity perpendicular to the plane of the board
$E_{t,0,mean}$	=	tensile modulus of elasticity in the plane of the board
$E_{t,90,mean}$	=	tensile modulus of elasticity perpendicular to the plane of the board
$f_{c,0,k}$	=	characteristic compressive strength in the plane of the board
$f_{c,90,k}$	=	characteristic compressive strength perpendicular to the plane of the board
$f_{h,0,k}$	=	characteristic embedment strength in the plane of the board
$f_{h,90,k}$	=	characteristic embedment strength perpendicular to the plane of the board
$f_{m,0,k}$	=	characteristic bending strength in the plane of the board

<sup>2</sup> The real working life of a product incorporated in a specific works depends on the environmental conditions to which that works is subject, as well as on the particular conditions of the design, execution, use and maintenance of that works. Therefore, it cannot be excluded that in certain cases the real working life of the product may also be shorter than referred to above.

$f_{m,90,k}$	=	characteristic bending strength perpendicular to the plane of the board
$f_{r,0,k}$	=	characteristic shear strength in the plane of the board in production direction
$f_{r,90,k}$	=	characteristic shear strength in the plane of the board perpendicular to the production direction
$f_{t,0,k}$	=	characteristic tensile strength in the plane of the board in production direction
$f_{t,90,k}$	=	characteristic tensile strength in the plane of the board perpendicular to the production direction
$f_{v,0,k}$	=	characteristic shear strength perpendicular to the plane of the board in production direction
$f_{v,90,k}$	=	characteristic shear strength perpendicular to the plane of the board perpendicular to the production direction
$f_{head,\alpha,k}$	=	characteristic pull through resistance
$G_{r,mean}$	=	shear modulus in the plane of the board
$G_{v,mean}$	=	shear modulus perpendicular to the plane of the board
WI	=	water impermeability

### Loads/Forces

F	=	force in general
N	=	normal force
V	=	shear force

### Tests/Assessment

$\lambda$	=	thermal conductivity
$\mu$	=	water vapour resistance value
$\delta_{l65,85}$	=	dimension stability as swelling
$\delta_{l65,30}$	=	dimension stability as shrinkage
$d_{support}$	=	diameter of supporting ring
$F_{i,v,Rd}$	=	racking resistance
$F_{max,k}$	=	characteristic breaking load
$F_{max,m}$	=	mean breaking load
h	=	height of specimen
H	=	moisture content
IR	=	impact resistance
$k_{def}$	=	deformation factor for the evaluation of creep deformation
$k_{mod}$	=	modification factor for duration
$K_{ser}$	=	slip modulus of the fastener
$m_a$	=	dry mass of specimen
$m_c$	=	saturated mass of specimen
$MOR_{fci}$	=	modulus of rupture of the i-th unexposed reference specimen (from the first lot)
r.H.	=	relative air humidity
$R_{L,FTC}$	=	ratio of modulus of rupture of exposed (freeze-thaw) and unexposed specimens
$R_{L,WW}$	=	ratio of modulus of rupture of exposed (warm-water) and unexposed specimens
$R_{L,SD}$	=	ratio of modulus of rupture of exposed (soak-dry) and unexposed specimens



## 2 ESSENTIAL CHARACTERISTICS AND RELEVANT ASSESSMENT METHODS AND CRITERIA

### 2.1 Essential characteristics of the product

Table 1 shows how the performance of the "Product" is assessed in relation to the essential characteristics. The specimens for the assessment of the "Product" shall stem from the equal batch.

**Table 1 Essential characteristics of the product and methods and criteria for assessing the performance of the product in relation to those essential characteristics**

No	Essential characteristic	Assessment method	Type of expression of product performance (level, class, description)
<b>Basic Works Requirement 1: Mechanical resistance and stability</b>			
1	Thickness*	2.2.1	level (e [mm])
2	Dimension (length and width)*	2.2.2	level (a = l x w [mm x mm])
3	Straightness of edges*	2.2.3	level (ste [%])
4	Squareness of edges*	2.2.4	level (sqe [mm/m])
5	Density*	2.2.5	level ( $\rho_m$ [kg/m <sup>3</sup> ])
6	Moisture content*	2.2.6	level (H [%by mass])
7	Water impermeability* (only for outdoor applications)	2.2.7	description (WI)
8	Dimensional stability*	2.2.8	level ( $\delta l_{65,85}$ , $\delta l_{65,30}$ [mm/m or %])
9	Modification factor	2.2.9	level ( $k_{mod}$ [-])
10	Deformation factor	2.2.10	level ( $k_{def}$ [-])
11	Bending strength/ bending modulus of elasticity	2.2.11	level ( $f_{m,0,k}$ ; $f_{m,90,k}$ ; $f_{m,0,mean}$ ; $f_{m,90,mean}$ ; $E_{m,0,mean}$ ; $E_{m,90,mean}$ [N/mm <sup>2</sup> ; N/mm <sup>2</sup> ])
12	Tensile strength / tensile modulus of elasticity	2.2.12	level ( $f_{t,0,k}$ ; $f_{t,90,k}$ ; $E_{t,0,mean}$ ; $E_{t,90,mean}$ [N/mm <sup>2</sup> ; N/mm <sup>2</sup> ])
13	Compressive strength / compressive modulus of elasticity	2.2.13	level ( $f_{c,0,k}$ ; $f_{c,90,k}$ ; $E_{c,0,mean}$ ; $E_{c,90,mean}$ [N/mm <sup>2</sup> ; N/mm <sup>2</sup> ])
14	Shear strength / shear modulus in the plane of the board	2.2.14	level ( $f_{r,0,k}$ ; $f_{r,90,k}$ ; $G_{r,0,mean}$ ; $G_{r,90,mean}$ [N/mm <sup>2</sup> ; N/mm <sup>2</sup> ])
15	Shear strength / shear modulus perpendicular to the plane of the board	2.2.15	level ( $f_{v,0,k}$ ; $f_{v,90,k}$ ; $G_{v,0,mean}$ ; $G_{v,90,mean}$ [N/mm <sup>2</sup> ; N/mm <sup>2</sup> ])
16	Embedment strength	2.2.16	level ( $f_{h,0,k}$ ; $f_{h,90,k}$ [N/mm <sup>2</sup> ])
17	Pull through resistance*	2.2.17	level ( $f_{head,\alpha,k}$ [N])
18	Influence of the edge distance of the fasteners on the embedment strength and slip modulus of the fasteners	2.2.18	level ( $a_{4,t}$ ; $a_{4,c}$ [mm]; $K_{ser}$ [MPa])
19	Racking resistance and stiffness	2.2.19	level ( $F_{i,v,Rd}$ [N])
20	Impact resistance*	2.2.20	level ( $IR_{mean}$ [mm/m])

No	Essential characteristic	Assessment method	Type of expression of product performance (level, class, description)
21	Water adsorption*	2.2.21	level ( $w_a$ [% by mass])
22	Freeze-thaw resistance (only for use in categories A, B and D)*	2.2.22	level ( $R_{L,FTC}$ [-])
23.	Heat-rain resistance (only for use in categories A and B)*	2.2.23	Description
24	Warm water resistance (only for use in categories A, B, C and D)*	2.2.24	level ( $R_{L,WW}$ [-])
25	Soak-dry resistance (only for use in categories A, B, C and D)*	2.2.25	level ( $R_{L,SD}$ [-])
26	Durability	2.2.26	Description
<b>Basic Works Requirement 2: Safety in case of fire</b>			
27	Reaction to fire	2.2.27	class
<b>Basic Works Requirement 3: Hygiene, health and the environment</b>			
28	Vapour Permeability	2.2.28	level ( $\mu$ [-])
29	Content, emission and/or release of dangerous substances	2.2.29	Description
<b>Basic Works Requirement 6: Energy economy and heat retention</b>			
30	Thermal conductivity	2.2.30	level ( $\lambda_{10,tr}$ [W/mK])
31	Air permeability	2.2.31	Description: "The "product" is not permeable to air"
*) These characteristics are also determined for non-structural applications.			

## 2.2 Methods and criteria for assessing the performance of the product in relation to essential characteristics of the product

### 2.2.1 Thickness

The thickness **e** of the "Product" shall be tested according to EN 12467, clause 7.2 for large size sheets.

The nominal value of the thickness **e** of the "Product" shall be given in the ETA. For boards (without texture), tolerances shall be in accordance with table 3 (see also EN 12467, clause 5.3.4.2, table 2).

Table 3: Tolerances on thickness

Thickness	Tolerance
6 mm < e ≤ 20 mm	± 10 % x e
e > 20 mm	± 2 mm

### 2.2.2 Dimension (Length and width)

The dimension **a** ((l) length and (w) width) of the "Product" shall be tested according to EN 12467, clause 7.2. for large size sheets.

The dimension **a** ((l) length and (w) width) of the "Product" shall be given in the ETA. Tolerances on length and width shall be in accordance with table 4 for the appropriate level (see also EN 12467, clause 5.3.4.1, table 1).

Table 4: Tolerances on nominal dimensions in accordance with value and level

Nominal dimension a *	Level I	Level II
$a \leq 600$ mm	$\pm 3$ mm	$\pm 4$ mm
$600 \text{ mm} < a \leq 1000$ mm	$\pm 3$ mm	$\pm 5$ mm
$1000 \text{ mm} < a \leq 1600$ mm	$\pm 0,3 \% \times a$	$\pm 0,5 \% \times a$
$1600 \text{ mm} < a$	$\pm 5$ mm	$\pm 8$ mm
* a is the nominal width or length		

### 2.2.3 Straightness of edges

The straightness of edges **ste** of the "Product" shall be tested according to EN 12467, clause 7.2.3.3.

The straightness of edges **ste** of the "Product" shall be given in the ETA.

The tolerances on the straightness of edges are defined as a percentage of the length of the edges shall be in accordance with table 5 for the appropriate level (see also EN 12467, clause 5.3.5.1, table 4).

Table 5: Tolerances on straightness of edges

Level I	Level II
0,1 %	0,3 %

### 2.2.4 Squareness of edges

The squareness of edges **sqe** of the "Product" shall be tested according to EN 12467, clause 7.2.3.4.

The squareness of edges **sqe** of the "Product" shall be given in the ETA.

The tolerances on the squareness of edges shall be in accordance with table 5 for the appropriate level (see also EN 12467, clause 5.3.5.2, table 5).

Table 5: Tolerances on Squareness of edges

Level I	Level II
2 mm/m	4 mm/m

### 2.2.5 Density

The density  $\rho$  of the "Product" shall be tested according to EN 12467, clause 7.3.1.

The mean value of density  $\rho_m$  of the "Product" shall be given in the ETA.

### 2.2.6 Moisture content

The moisture content **H** shall be tested according to EN 322 by storing the specimens at a standard climate (20°C / 65 % air humidity). It is recommended to evaluate the moisture content at 10 test specimens.

The moisture content **H** shall be given in the ETA.

### 2.2.7 Water impermeability (only for outdoor applications)

The water impermeability **WI** shall be tested according to EN 12467, clause 7.3.3 for boards which are intended to be used for categories A, B or D, see clause 1.2.1.

The boards are water impermeable when traces of moisture may appear on the underside surface of the board, but in no instance shall there be any formation of drops of water.

The water impermeability **WI** of the "Product" shall be given in the ETA.

### 2.2.8 Dimensional stability

The dimensional stability  $\delta l_{65,30}$ ,  $\delta l_{65,85}$  shall be tested on the basis of shrinkage and swelling behaviour of the board. The shrinkage and swelling shall be tested according to EN 318.

The dimension stability measured as shrinkage and swelling  $\delta l_{65,30}$ ,  $\delta l_{65,85}$  of the "Product" shall be given in the ETA.

### 2.2.9 Modification factor

The modification factor  $k_{mod}$  for duration of load and for moisture content to estimate the design value  $R_d$  of a resistance (load-carrying capacity) shall be determined according to Annex A.

The used test procedures of Annex A depend on the service class according to EN 1995-1-1 under which the boards shall be used, see also clause 1.2.1. For service classes 1 and 2 clause A.4 and for service class 3 clause A.5 shall be applied.

For each stress level 5 specimens shall be tested.

The modification factor  $k_{mod}$  for the different load-duration classes and service classes according to EN 1995-1-1 in which the board will be used shall be given in ETA.

### 2.2.10 Deformation factor

The deformation factor  $k_{def}$  for the evaluation of creep deformation taking into account the relevant service class shall be tested according to Annex A.

The measurement of creep shall be performed according to EN 1156.

For each stress level 5 specimens shall be tested.

The modification factor  $k_{def}$  for the service classes according to EN 1995-1-1 in which the board will be used shall be given in the ETA.

### 2.2.11 Bending strength and bending modulus of elasticity

The bending strength ( $f_{m,0,k}$  /  $f_{m,90,k}$ ) the bending modulus of elasticity ( $E_{m,0,mean}$  /  $E_{m,90,mean}$ ) and the type of bending behaviour shall be tested by the test method given in Annex B after storage under climatic condition (20 °C/65 % r.H.) until equilibrium of mass. The equilibrium of mass under climate at 20°C and 65 % r. H. is reached if the mass has a lower difference than 0,1 % in weighting with an interval of 24 h.

10 specimens shall be taken and tested parallel resp. perpendicular to the production direction.

The characteristic values (5 % quantile with 75 % confidence level) shall be calculated according to EN 14358.

The characteristic value of the bending strength ( $f_{m,0,k}$  /  $f_{m,90,k}$ ) and the mean value of the bending modulus of elasticity ( $E_{m,0,mean}$  /  $E_{m,90,mean}$ ) shall be given in the ETA.

### 2.2.12 Tensile strength and tensile modulus of elasticity in plane of the board

The tensile strength ( $f_{t,0,k}$ ;  $f_{t,90,k}$ ) and tensile modulus of elasticity ( $E_{t,0,mean}$ ;  $E_{t,90,mean}$ ) in the plane of the boards shall be tested according to EN 789.

The dimensions of the specimen shall be  $W \times L \times t = (50 \text{ mm} / 30 \text{ mm}) \times 300 \text{ mm} \times t$ , see Figure 1. Alternatively it is possible to use the dimensions of the specimen according to EN 789, Figure 5.

The specimens shall be stored under climatic conditions (20 °C/65 % r.H.) for 14 days.

10 specimens shall be taken and tested parallel resp. perpendicular to the production direction.

The evaluation of the tensile strength shall be performed according to EN 789. The characteristic values (5 % quantile with 75 % confidence level) shall be calculated according to EN 14358.

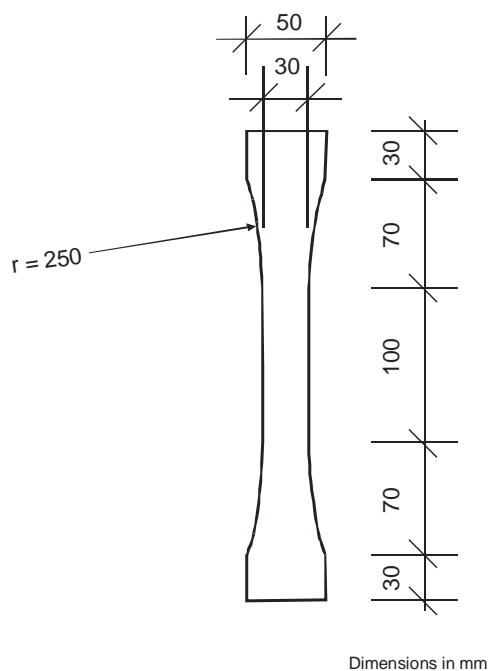

Figure 1: Dimension of the specimen for testing the tensile strength

The characteristic value of the tensile strength ( $f_{t,0,k}$ ;  $f_{t,90,k}$ ) and the mean value of the tensile modulus of elasticity for each loading direction ( $E_{t,0,mean}$ ;  $E_{t,90,mean}$ ) in the plane of the boards shall be given in the ETA.

### 2.2.13 Compressive strength and compressive modulus of elasticity

The compressive strength ( $f_{c,0,k}$ ;  $f_{c,90,k}$ ) and compressive modulus of elasticity ( $E_{c,0,mean}$ ;  $E_{c,90,mean}$ ) perpendicular to the plane and in the plane of the board shall be tested according to EN 789.

The specimens shall be stored under climatic conditions (20 °C/ 65 % r.H.) for 14 days.

10 specimens shall be taken and tested parallel resp. perpendicular to the production direction.

The evaluation of the compressive strength shall be performed according to EN 789. The characteristic values (5 % quantile with 75 % confidence level) shall be calculated according to EN 14358.

The characteristic value of the compressive strength ( $f_{c,0,k}$ ;  $f_{c,90,k}$ ) and the mean value of the compressive modulus of elasticity ( $E_{c,0,mean}$ ;  $E_{c,90,mean}$ ) shall be given in the ETA.

### 2.2.14 Shear strength and shear modulus in the plane of the board

The shear strength ( $f_{r,0,k}$ ;  $f_{r,90,k}$ ) and shear modulus ( $G_{r,0,mean}$ ;  $G_{r,90,mean}$ ) in the plane of the board shall be tested according to EN 789, clause 11.

10 specimens shall be taken and tested parallel to the production direction.

The load F shall be applied with constant rate, maximum load shall be reached in  $300 \text{ s} \pm 120 \text{ s}$ .

The specimens shall be stored under climatic conditions (20 °C/65 % r.H.) for 14 days.

The evaluation of the shear strength in plane to the board shall be performed according to EN 789, clause 11. The characteristic values (5 % quantile with 75 % confidence level) shall be calculated according to EN 14358.

The characteristic value of the shear strength ( $f_{r,0,k}$ ;  $f_{r,90,k}$ ) and the mean value of the shear modulus ( $G_{r,0,mean}$ ;  $G_{r,90,mean}$ ) in the plane of the board shall be given in the ETA.

### 2.2.15 Shear strength and shear modulus perpendicular to the plane of the board

The shear strength ( $f_{v,0,k}$ ,  $f_{v,90,k}$ ) and shear modulus perpendicular to the plane of the board ( $G_{v,0,mean}$ ;  $G_{v,90,mean}$ ) shall be tested according to EN 789, clause 10.

10 specimens shall be taken and tested perpendicular to the production direction.

The load F shall be applied with constant rate, maximum load shall be reached in  $300 \pm 120$  s.

The specimens shall be stored under climatic conditions (20 °C/65 % r.H.) for 14 days.

The evaluation of the shear strength perpendicular to the plane of the board shall be performed according to EN 789, clause 10. The characteristic values (5 % quantile with 75 % confidence level) shall be calculated according to EN 14358.

The characteristic value of the shear strength ( $f_{v,0,k}$ ;  $f_{v,90,k}$ ) and the mean value of the shear modulus perpendicular to the plane of the board ( $G_{v,0,mean}$ ;  $G_{v,90,mean}$ ) shall be given in the ETA.

### 2.2.16 Embedment strength

The execution of the embedment strength will be based on EN 383.

10 specimen of each thickness, diameter of dowel type fasteners and orientation (0° and 90°) will be tested. The dimensions of the specimen shall be w x l (100 mm x 150 mm):

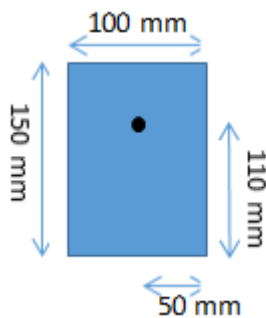

with: Fasteners diameter  $d = x$

The fasteners were placed central in the width of the leveled edge with a distance of 110 mm of the lower end. Before starting of the test series the expected maximum load was stated. According to this maximum load the load-cycle  $F_{max,est}$  according EN 383 was defined.

The specimens shall be stored under climatic conditions (20 °C/65 % r.H.) until equilibrium of mass. The equilibrium of mass is reached if the mass has a lower difference than 0,1 % in weighing with an interval of 24 h.

The tests shall be carried out under climatic conditions (20°C / 65 % r.H.).

The test shall be carried out with steel plate to eliminate the deformation component  $w_0$  of the fastener and of the test device.

Cracks on the surface and the face side of the board which are higher than 0,1 mm caused by installing the fastener are not allowed. No more than 5 % of the surface and face side cracks caused by the installation of the fasteners may have a crack width higher than 0,05 mm.

The evaluation of the embedment strength depending on the fastener diameter shall be performed according to EN 383. The characteristic values (5 % quantile with 75 % confidence level) shall be calculated according to EN 14358.

The characteristic values of the embedment strength ( $f_{h,0,k}$ ,  $f_{h,90,k}$ ) shall be given for each tested fastener respectively depending on the fastener diameter in the ETA.

### 2.2.17 Pull through resistance

The pull through resistance ( $f_{head,\alpha,k}$ ) shall be determined according to EN 1383. The diameter of the supporting ring  $d_{support}$  shall be chosen between 80 mm and 240 mm.

The specimens shall be stored under climatic conditions (20 °C/65 % r.H.) until equilibrium of mass. The equilibrium of mass is reached if the mass has a lower difference than 0,1 % in weighing with an interval of 24 h.

The test shall be carried out on 20 specimens of each fastener and each procedure of installing the fastener which is intended for the "Product".

For rivets the pull through resistance has to be determined by testing the complete fixing kit (Board, rivet and substructure – Dimensions and material grade of sheet, substructure and rivet need to be reported).

The evaluation of the pull through resistance of the fastener subject to the board shall be performed according to EN 1383. The characteristic values (5 % quantile with 75 % confidence level) shall be calculated according to EN 14358.

Cracks on the surface and the face side of the "Product" which are higher than 0,1 mm caused by installing the fastener are not allowed. No more than 5 % of the surface and face side cracks caused by the installation of the fasteners may have a crack width higher than 0,05 mm.

The characteristic pull through resistance ( $f_{heat,\alpha,k}$ ) for each tested fastener shall be given in the ETA.

### 2.2.18 Influence of the edge distance of the fasteners on the embedment strength and slip modulus of the fastener

The influence of the edge distance of the fasteners on the embedment strength ( $f_{h,\alpha,k}$ ) and slip modulus of the fastener ( $K_{ser}$ ) shall be determined according to EN 1380 for nails, dowels and bolts or, according to EN 1381, for staples. All different diameters of fasteners intend to fix the sheet shall be regarded (cf. EN 1995-1-1).

The tests shall be carried out with the direction of the load  $\perp$  to the loaded edge ( $a_{4,t}$ ) and with the direction of the load  $\parallel$  to the unloaded edge ( $a_{4,c}$ ).

The influence of the edge distance need to be regarded to determine the load bearing resistance of a fastener depending on the distance to the edge, see example below.

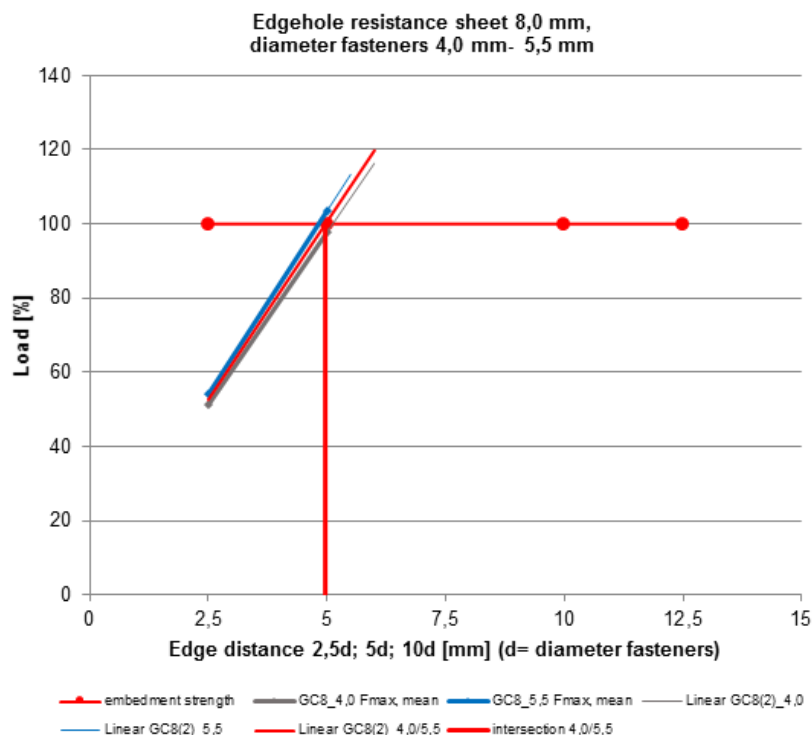

According to test results or expert experience it is necessary to define a distance to edge or a reduction of the load bearing resistance of the fastener.

5 specimens of each fastener and each procedure of installing the fastener which is intended for the "Product" shall be tested. The test shall be carried out with different edge distances.

Cracks on the surface and the face side of the panel caused by installing the fastener which are higher than 0,1 mm are not allowed. No more than 5 % of the surface and face side cracks caused by the installation of the fasteners may have a crack width higher than 0,05 mm.

The evaluation of testing edge distance of the fasteners shall be performed according to EN 26891.

The influence of the edge distance of the fasteners on the embedment strength ( $a_{4,t}$ ,  $a_{4,c}$ ) and the slip modulus ( $K_{ser}$ ) shall be given in the ETA.

### 2.2.19 Racking resistance

At first the racking resistance and stiffness of timber frame wall panels shall be tested according to EN 594. At least two configurations with the minimum and maximum number of fasteners shall be tested.

For the verification of the low fatigue behaviour also specimens and the test setup according to EN 594 shall be used. Unlike to static loading for the verification of the fatigue behaviour 100 load cycles with an upper load of 70 % and a lower load of -70 % of the average static failure load shall be applied. The load deflection curve shall be recorded. Afterwards the static failure load shall be determined according to EN 594.

The tests shall be carried out under conditions of regular application.

The racking resistance ( $F_{i,v,Rd}$ ) and stiffness of timber frame wall panels shall be compared with the results of the calculation method according to EN 1995-1-1, clause 9.2.4. If no correspondence with the above mentioned design procedure can be proved, the causes are to be ascertained and necessary modifications of the design procedure in the evaluation report are to be explained.

If quotient of the average static failure load of the low fatigue damaged specimen by the average static failure load of the not pre-damaged specimen is  $> 0,75$  and maximum deflection at fatigue loading is less than  $0,05 \times h$  ( $h$  height of specimen) the requirement for low fatigue behaviour is fulfilled.

The value of the racking resistance ( $F_{i,v,Rd}$ ) shall be given in the ETA.

### 2.2.20 Impact resistance

The impact resistance (**IR**) shall be tested according to EN 1128. The specimens shall be stored under normal climatic conditions of 20 °C and 65 % r.H. until equilibrium of mass. The equilibrium of mass under climate 20 °C and 65 % r.H. is reached if the mass has a lower difference than 0,1 % in weighting with an interval of 24 h.

The mean value of the impact resistance ( $IR_{mean}$ ) shall be given in the ETA.

### 2.2.21 Water absorption

The specimens must be cut from the component using a silicon carbide saw or other appropriate equipment. The specimens must be rectangular with parallel sides perpendicular to the mould or machine face of the sample.

The thickness of specimens must not vary by more than  $\pm 10$  % of the nominal specimen thickness, or  $\pm 1$  mm, whichever is less. Specimens must have a volume of at least 25 cm<sup>3</sup>. Loose particles of dust must be removed using an air blast.

Mass must be measured to an accuracy of  $\pm 0,05$  g. Weighing scale accuracy of  $\pm 0,01$  % and equipped to determine the immersed weight and the non-immersed weight of the specimen is necessary. The specimens must be immersed in water at  $(20 \pm 2)$  °C for not less than 24 hours. Specimens must be kept immersed until successive immersed mass determinations of individual specimens at intervals of 2 hours show an increase of less than 0,5 %.



The specimens are removed from the water and the surface dried quickly with a towel to remove surface moisture. The saturated mass ( $m_c$ ) of each specimen in air must be determined.

Specimens must be dried in an oven at  $(105 \pm 5)$  °C until successive mass determinations at intervals of 2 hours show a decrease of less than 0,5 %. A forced circulation oven capable of achieving a temperature of between 100 °C and 110 °C with a full load of specimens is necessary. After removal from the oven, the specimen should be placed in a desiccator and allowed to cool to ambient temperature. The dry mass ( $m_a$ ) of the specimen is then determined.

The tests shall be carried out on 10 specimens.

The test report must include:

- Identification of specimens
- Description of the material
- Conditioning of the specimen
- Date of test
- Age of specimen at test
- Method of test
- Number of specimens taken as test sample
- Specimen dimensions
- Individual and mean values of water absorption.

The water absorption ( $w_a$ ) is given by the formula:

$$w_a = \frac{m_c - m_a}{m_a} \times 100\%$$

where  $m_a$  and  $m_c$  are the dry and saturated mass respectively as defined above.

The water absorption ( $w_a$ ) of the board shall be given in the ETA.

### 2.2.22 Freeze-thaw resistance

The freeze-thaw resistance shall be tested according to EN 12467, clause 7.4.1.

The testing of the bending strength after freeze-thaw cycling and reference storage for one sheet type shall be at the same sheet age respectively specimen age. Deviant from EN 12467 constant moisture content is considered to be reached between 1 weeks and 6 weeks.

If the breaking load  $F_{max,k}$  of boards with ductile bending behaviour (see Annex B, B.6.1, Figure B.2.b) shall be used to define the ultimate limit state the test shall be done with boards in the cracked state.

Also in the case of boards with ductile behaviour tests with cracked boards may be avoided if  $F_{crack,k}$  (see Annex B, B.6.1, Figure B.2.b) is used to define the ultimate limit state.

Before testing the freeze-thaw resistance all specimens shall be loaded with  $0,6 F_{max,m}$  on both sides.  $F_{max,m}$  in this case is the average load at  $MOR_{fci}$  of the samples tested for reference (see EN 12467, clause 7.4.1.4).

The specimens of categories A and B shall be stored according to EN 12467, Table 10, row 4. But after 7 days intermediate storage under climatic conditions (23 °C/50 % r.H.) the specimens shall be stored 24 h immersed in water for boards with thickness  $\leq 20$  mm or 48 h for thickness  $> 20$  mm. The specimens shall be tested immediately upon removal from the water.

Specimens of category D shall be stored under climatic conditions (23 °C/50 % r.H.) for 14 days.

The specimen for the reference storage for testing "Product" for the use in categories A and B shall be stored according to EN 12467, Table 10, row 2.

The specimen for the reference storage for testing "Product" for the use in category D shall be stored according to EN 12467, Table 10, row 3.

The testing of the bending strength after freeze-thaw-cycles and reference storage for each board type shall be at the same board age respectively specimen age.

When tested in accordance with EN 12467, clause 7.4.1 after 100 freeze-thaw-cycles for category A and 25 cycles for category B and D, the ratio  $R_{L,FTW}$  as defined in EN 12467, clause 7.4.1.4, shall be not less than 0,75 according to EN 12467, clause 5.5.2.

The freeze-thaw resistance respectively the average ratio of the modulus of rupture of exposed and unexposed specimens  $R_{L,ftc}$  shall be given in the ETA.

### 2.2.23 Heat-rain resistance

The heat-rain resistance shall be determined according to EN 12467, clause 7.4.2.

The specimens of categories A and B shall be stored according to EN 12467, Table 10, row 4. But after 7 days intermediate storage under climatic conditions (23 °C/50 % r.H.) the specimens shall be stored 24 h immersed in water for boards with thickness  $\leq 20$  mm or 48 h for thickness  $> 20$  mm. The specimens shall be tested immediately upon removal from the water.

Specimen for the reference storage for testing "Product" for the use in categories A and B shall be stored according to EN 12467, Table 10, row 2.

When tested in accordance with EN 12467, clause 7.4.2 after 50 heat-rain cycles for category A and 25 cycles for category B, any visible cracks, delamination, warping and bowing or other defects in the board shall not have such a degree as to affect their performance in use.

The heat-rain resistance of the "Product" shall be given in the ETA.

### 2.2.24 Warm water resistance

The warm water resistance shall be determined according to EN 12467, clause 7.3.5.

If the breaking load  $F_{max,k}$  of boards with ductile bending behaviour (see Annex B, B.6.1, Figure B.2.b) shall be used to define the ultimate limit state the test shall be done with boards in the cracked state.

Also in the case of boards with ductile behaviour tests with cracked boards may be avoided if  $F_{crack,k}$  (see Annex B, B.6.1, Figure B.2.b) is used to define the ultimate limit state.

Before testing the warm water resistance all specimens shall be loaded with 0,6  $F_{max,m}$  on both sides.  $F_{max,m}$  in this case is the average load at  $MOR_{fci}$  of the samples tested for reference (see EN 12467, clause 7.3.5.4).

The specimens of categories A and B shall be stored according to EN 12467, Table 10, row 4. But after 7 days intermediate storage under normal climatic conditions (23 °C/50 % r.H.) the specimens shall be stored 24 h immersed in water for boards with thickness  $\leq 20$  mm or 48 h for thickness  $> 20$  mm. The specimens shall be tested immediately upon removal from the water.

Specimens of categories C and D shall be stored under climatic conditions (23 °C/50 % r.H.) for 14 days.

The specimen for the reference storage for testing "Product" for the use in categories A and B shall be stored according to EN 12467, Table 10, row 2.

The specimen for the reference storage for testing "Product" for the use in categories C and D shall be stored according to EN 12467, Table 10, row 3.

The testing of the bending strength after warm water test and reference storage for one board type shall be at the same board age respectively specimen age.

When tested in accordance with EN 12467, clause 7.3.5 after 56 days at 60 °C, the ratio  $R_{L,ww}$  as defined in EN 12467, clause 7.3.5.4, shall be not less than 0,75 according to EN 12467, clause 5.5.4.

The warm water resistance respectively the average ratio of the modulus of rupture of exposed and unexposed specimens  $R_{L,ww}$  shall be given in the ETA.

### 2.2.25 Soak-dry resistance

The soak-dry resistance shall be tested according to EN 12467, clause 7.3.6.

If the breaking load  $F_{\max,k}$  of boards with ductile bending behaviour (see Annex B, B.6.1, Figure B.2.b) shall be used to define the ultimate limit state the test shall be done with boards in the cracked state.

Also in the case of boards with ductile behaviour tests with cracked boards may be avoided if  $F_{\text{crack},k}$  (see Annex B, B.6.1, Figure B.2.b) is used to define the ultimate limit state.

Before testing the soak-dry all specimens shall be loaded with  $0,6 F_{\max,m}$  on both sides.  $F_{\max,m}$  in this case is the average load at  $MOR_{fci}$  of the samples tested for reference (see EN 12467, clause 7.3.6.4).

The specimens of categories A and B shall be stored according to EN 12467, Table 10, row 4. But after 7 days intermediate storage under climatic conditions (23 °C/50 % r.H.) the specimens shall be stored 24 h immersed in water for boards with thickness  $\leq 20$  mm or 48 h for thickness  $> 20$  mm. The specimens shall be tested immediately upon removal from the water.

For specimens of categories C and D shall be stored under climatic conditions (23 °C/50 % r.H.) for 14 days.

The specimen for the reference storage for testing "Product" for the use in categories A and B shall be stored according to EN 12467, Table 10, row 2.

The specimen for the reference storage for testing "Product" for the use in categories C and D shall be stored according to EN 12467, Table 10, row 3.

The testing of the bending strength after soak-dry-cycles and reference storage for each board type shall be at the same board age respectively specimen age.

When tested in accordance with EN 12467, clause 7.3.6 after 50 soak-dry-cycles for category A and after 25 cycles for categories B, C and D, the ratio  $R_{L,SD}$  as defined in EN 12467, clause 7.3.6.4 shall be not less than 0,75 according to EN 12467, clause 5.5.5.

The soak dry resistance respectively the average ratio of the modulus of rupture of exposed and unexposed specimens  $R_{L,SD}$  shall be given in the ETA.

### 2.2.26 Durability

#### Metal parts (corrosion)

The assessment/testing required with respect to corrosion resistance will depend on the specification of the anchor in relation to its use. Supporting evidence that corrosion will not occur is not required if the steel parts of the metal anchor are protected against corrosion, as set out below:

- (1) Fasteners intended for use in structures subject to dry, internal conditions:

No special corrosion protection is necessary for steel parts as coatings provided for preventing corrosion during storage prior to use and for ensuring proper functioning (zinc coating with a minimum thickness of 5 microns) is considered sufficient.

- (2) Fasteners for use in structures subject to external atmospheric exposure (including industrial and marine environments), or exposure in permanently damp internal conditions, if no particular aggressive conditions according to (3) exist:

Metal parts of the fasteners made of stainless steel material 1.4401, 1.4404, 1.4578, 1.4571, 1.4362, 1.4062, 1.4162, 1.4662, 1.4439, 1.4462 or 1.4539 according to EN 10088-4 and EN 10088-5 are considered to have sufficient durability.

- (3) Fasteners for use in structures subject to external atmospheric exposure or exposure in permanently damp internal conditions or particularly aggressive conditions such as permanent or alternate immersion in seawater or the splash zone of seawater, chloride atmosphere of indoor swimming pools or atmosphere with extreme chemical pollution (e.g. in desulfurization plants or road tunnels, where de-icing materials are used):

Metal parts of the fasteners of stainless steel material 1.4529, 1.4565 and 1.4547 according to EN 10088-4 and EN 10088-5 are considered to have sufficient durability.

### 2.2.27 Reaction to fire

The "Product" shall be tested, using the test method(s) relevant for the corresponding reaction to fire class, in order to be classified according to EN 13501-1 in connection with Commission Delegated Regulation (EU) 2016/364.

Note: EN 13501-1:2007+A1:2009 still refers to Commission Decision 2000/147/EC which has in the meanwhile be replaced by the Commission Delegated Regulation (EU) 2016/364 of 1 July 2015.

The mounting and fixing conditions are described in Annex C.

If the product is considered to satisfy the requirements for performance class A1 of the characteristic reaction to fire, in accordance with the provisions of EC decision 96/603/EC (as amended) there is no need for testing on the basis of its listing in that decision.

### 2.2.28 Vapour permeability

The vapour permeability ( $\mu$ ) shall be tested according to EN ISO 12572, clause 7.3.

The mean value of the vapour permeability ( $\mu$ ) shall be given in the ETA.

### 2.2.29 Content, emission and/or release of dangerous substances

#### 2.2.29.1 General

The performance of the product related to the emissions and/or release and, where appropriate, the content of dangerous substances will be assessed on the basis of the information provided by the manufacturer<sup>3</sup> after identifying the release scenarios (in accordance with EOTA TR 034) taking into account the intended use of the product and the Member States where the manufacturer intends his product to be made available on the market.

The identified intended release scenarios for this product and intended use with respect to dangerous substances are:

- IA1: Product with direct contact to indoor air.
- IA2: Product with indirect contact to indoor air (e.g covered products) but possible impact on indoor air.

#### 2.2.29.2 SVOC and VOC

For the intended use covered by the release scenarios IA1 and IA2 semi-volatile organic compounds (SVOC) and volatile organic compounds (VOC) are to be determined in accordance with EN 16516. The respective loading factor [ $\text{m}^2/\text{m}^3$ ] used for emission testing can be taken from Table 6.

Table 6: Loading factor L, depending on the product type (in accordance with EN 16516)

Intended use	Loading factor L
-	[ $\text{m}^2/\text{m}^3$ ]
Walls	1,0
Floor, ceiling	0,4

<sup>3</sup> The manufacturer may be asked to provide to the TAB the REACH related information which he must accompany the DoP with (cf. Article 6(5) of Regulation (EU) No 305/2011).

The manufacturer is **not** obliged:

- to provide the chemical constitution and composition of the product (or of constituents of the product) to the TAB, or
- to provide a written declaration to the TAB stating whether the product (or constituents of the product) contain(s) substances which are classified as dangerous according to Directive 67/548/EEC and Regulation (EC) No 1272/2008 and listed in the "Indicative list on dangerous substances" of the SGDS.

Any information provided by the manufacturer regarding the chemical composition of the products may not be distributed to EOTA or to TABs.

The test specimen shall be assembled according to the envisaged application appropriate to the size of the test chamber. The installation should be in accordance with the manufacturer's product installation instructions or (in absence of such instructions) the usual practice of installation.

Once the test specimen has been produced, as described above, it should immediately be placed in the emission test chamber. This time is considered the starting time of the emission test.

The test results have to be reported for the relevant parameters (e.g. chamber size, temperature and relative humidity, air exchange rate, loading factor, size of test specimen, conditioning, production date, arrival date, test period, test result) after 3 and 28 days testing.

The relevant test results shall be expressed in [mg/m<sup>3</sup>] and stated in the ETA.

### **2.2.30 Thermal conductivity**

The thermal conductivity ( $\lambda$ ) at 10°C and under dry condition shall be tested according to EN 12664.

The influence of humidity on the thermal conductivity shall be given by storing the specimen at a climate of 23 °C and 50 % r.H. and/or 23 °C and 80 % r.H. followed by measuring according to EN 12664.

The thermal conductivity shall be measured on specimens covering the entire range of density.

The assessment is done on three specimens.

The mean value at 23 °C and 50 % r.H. the thermal conductivity ( $\lambda$ ) shall be determined on the basis of the measuring results in accordance with EN ISO 10456 and shall be given in the ETA.

If necessary the moisture conversion factor for the conversion to 23 °C and 80 % r.H. shall be given in the ETA. The level shall be representative for the entire range of density.

### **2.2.31 Air permeability**

The air permeability shall not be determined experimentally, since the board is airtight.

If necessary the manufacturer shall give an information about the air permeability of the board: "The board is not permeable to air".

### 3 ASSESSMENT AND VERIFICATION OF CONSTANCY OF PERFORMANCE

#### 3.1 Systems of assessment and verification of constancy of performance to be applied

For the products covered by this EAD the applicable European legal act is: Decision 1998/437/EC

The systems are: 3 and 4

In addition, with regard to reaction to fire for products covered by this EAD the applicable European legal act is: Decision 1998/437/EC(EU)

The systems are: 1, 3 and 4

#### 3.2 Tasks of the manufacturer

The cornerstones of the actions to be undertaken by the manufacturer of the product in the procedure of assessment and verification of constancy of performance are laid down in Table 7.

**Table 7 Control plan for the manufacturer; cornerstones**

No	Subject/type of control (product, raw/constituent material, component - indicating characteristic concerned)	Test or control method	Criteria, if any	Minimum number of samples	Minimum frequency of control
<b>Factory production control (FPC)</b> [including testing of samples taken at the factory in accordance with a prescribed test plan]					
1	Description and checking of the raw materials and components	-	-	-	each supplied charge
2	Thickness	2.2.1	Control plan	3 boards	daily
3	Length and width	2.2.2		3 boards	daily
4	Straightness of edges	2.2.3		3 boards	daily
5	Squareness of edges	2.2.5		3 boards	daily
6	Density	2.2.6		3 specimens	daily
7	Bending strength	2.2.12		8 specimens : 2 specimens bending perpendicular to the plane in direction of production with front and back site in the compressive zone, 2 specimens bending perpendicular to the plane and perpendicular to direction of production with front and back site in the compressive zone	daily

### 3.3 Tasks of the notified body

The cornerstones of the actions to be undertaken by the notified body of the product in the procedure of assessment and verification of constancy of performance are laid down in Table 8.

**Table 8 Control plan for the notified body; cornerstones**

No	Subject/type of control ( <i>product, raw/constituent material, component</i> <i>- indicating characteristic concerned</i> )	Test or control method	Criteria, if any	Minimum number of samples	Minimum frequency of control
<b>Initial inspection of the manufacturing plant and of factory production control</b> ( <i>for system 1 only</i> )					
1	Ascertain that the factory production control with the staff and equipment are suitable to ensure a continuous and orderly manufacturing of the "Product".	-	Laid down in control plan	-	1
<b>Continuous surveillance, assessment and evaluation of factory production control</b> ( <i>for system 1 only</i> )					
2	Verifying that the system of factory production control and the specified automated manufacturing process are maintained taking account of the control plan.	-	Laid down in control plan	-	2/year

## 4 REFERENCE DOCUMENTS

As far as no edition date is given in the list of standards thereafter, the standard in its current version at the time of issuing the European Technical Assessment is of relevance.

EN 197-1	Cement – Part 1: Composition, specifications and conformity criteria for common cements
EN 318	Wood-based panels – Determination of dimensional changes associated with changes in relative humidity
EN 322	Wood-based panels - Determination of moisture content
EN 383	Timber Structures - Test methods - Determination of embedment strength and foundation values for dowel type fasteners
EN 594	Timber structures - Test methods - Racking strength and stiffness of structural wall panels
EN 789	Timber structures - Test methods - Determination of mechanical properties of wood based panels
EN 1128	Cement-bounded particleboards - Determination of hard body impact resistance
EN 1380	Timber structures - Test methods - Load bearing nails, screws, dowels and bolts
EN 1381	Timber structures - Test methods - Load bearing stapled joints
EN 1383	Timber structures - Test methods - Pull through resistance of timber fasteners
EN 1995-1-1	Eurocode 5: Design of timber structures – Part 1-1: General – Common rules and rules for buildings
EN ISO 1716	Reaction to fire tests for building products - Determination of the heat of combustion
EN ISO 10456	Building materials and products - Hygrothermal properties - Tabulated design values and procedures for determining declared and design thermal values
EN 10088-4	Stainless steels – Part 4: Technical delivery conditions for sheet/plate and strip of corrosion resisting steels for construction purposes
EN 10088-5	Stainless steels – Part 5: Technical delivery conditions for bars, rods, wire, sections and bright products of corrosion resisting steels for construction purposes
EN ISO 12572	Hygrothermal performance of building materials and products - Determination of water vapour transmission properties
EN 12467	Fibre cement flat sheets - Product specification and test methods
EN 12664	Thermal performance of building materials and products - Determination of thermal resistance by means of guarded hot plate and heat flow meter methods - Dry and moist products with medium and low thermal resistance
EN 13238	Reaction to fire tests for building products - Conditioning procedures and general rules for selection of substrates
EN 13501-1	Fire classification of construction products and building elements – Part 1: Classification using test data from reaction to fire tests
EN 14358	Timber structures - Calculation of characteristic 5-percentile values and acceptance criteria for a sample



EN 16516	Construction products - Assessment of release of dangerous substances - Determination of emissions into indoor air
EN 26891	Timber structures; joints made with mechanical fasteners; general principles for the determination of strength and deformation characteristics (ISO 6891:1983)
EOTA TR 034	EOTA Technical Report TR 034: General checklist for EADs/ETAs – Content and/or release of dangerous substances in construction products

## ANNEX A EVALUATION OF THE INFLUENCE OF MOISTURE AND LOAD DURATION

Version: June 2016

### A.1 References

EN 1156	Wood-based panels - Determination of duration of load and creep factors
EN 1995-1-1	Eurocode 5: Design of timber structures – Part 1-1: General – Common rules and rules for buildings
EN 12467	Fibre cement flat sheets - Product specification and test methods

### A.2 Scope

Structural "Product" used for planking and lining of walls, ceilings and roof trusses in service class 2 and service class 3 according to EN 1995-1-1 must prove their moisture resistance by reaching one of the categories A, B, C or D according to EN 12467.

### A.3 Sampling and test set up

#### A.3.1 Sampling and making of sampling

It is recommended to take 5 strips (specimens) per load level. The specimens shall be cut off having the dimensions listed below. When cutting the samples, a minimum distance of 100 mm off the edge and 10 mm away from the next sample shall be kept. The samples shall be marked.

The dimensions of the specimen  $W \times L \times e$  shall be

Width	$W$	=	50	[mm]
Span	$l_A$	≥	570	[mm]
Length	$L$	=	$l_A + 50$	[mm]
Thickness	$e$			[mm]

#### A3.2 Assembly of the tester

The strips are placed in an assembly on which the dead load  $g$  is set up in a 4-point bending test.

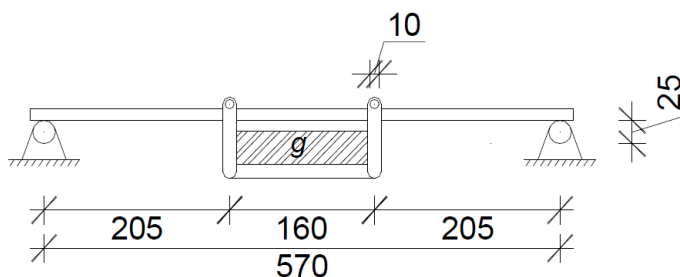

Figure A: Test set-up for creep and duration of load

### A.4 Service class 1 and 2 according to EN 1995-1-1

#### A.4.1 Step 1 (short-term load-duration)

To evaluate the influence of moisture on the strength and stiffness of structural "Product" the bending strength and bending modulus of elasticity perpendicular to the plane of the board shall be compared under normal climatic conditions of 20 °C / 65 % r.H. to humid climatic conditions of 20 °C / 85 % r.H..

Determination of the characteristic bending strength perpendicular to the plane of the board under normal climatic conditions of 20 °C / 65 % r.H. and humid climatic conditions of 20 °C / 85 % r.H..

#### A.4.2 Step 2 (long-term load-duration)

The influence of the load duration under normal climatic conditions of 20 °C / 65 % r.H. and humid climatic conditions of 20 °C / 85 % r.H. shall be evaluated according to EN 1156 by application of a static load on the specimen, test-configuration according to EN 1156. The dimensions of the specimen shall be the same as chosen under step 1.

Based on the results of step 1 and 2, considering the evaluation methods of EN 1156, the testing laboratory shall determine  $k_{mod}$  for the service classes 1 and 2 according to EN 1995-1-1.

## **A.5 Service class 3 according to EN 1995-1-1 without outdoor exposure**

### **A.5.1 Step 1 (short-term load-duration)**

Service Class 2 according to EN 1995-1-1 (see A.4.1) must be proved.

To evaluate the influence of moisture on the strength and stiffness of structural boards the bending strength and bending modulus of elasticity perpendicular to the plane of the board shall be compared under normal climatic conditions of 20 °C / 65 % r.H. and climatic conditions of 30 °C / 95 % r.H. for class X1 boards, under climatic conditions of 60 °C / 95 % r.H. and 90 °C / 30 % r.H. for class X2 boards and/or 20 °C / 95 % r.H. for class Y boards.

Dimension of the specimen, bending test and bending test machine according to A.3.

The characteristic bending strength perpendicular to the plane of the board under climatic conditions of 30 °C / 95 % r.H. for class X1 boards, under climatic conditions of 60 °C / 95 % r.H. and 90 °C / 30 % r.H. for class X2 boards or 20 °C / 95 % r.H. for class Y boards shall be determined.

Note:     Class X1:       Boards which are intended for applications like indoor swimming pool and shower room.  
           Class X2:       Boards which are intended for applications like sauna.  
           Class Y:        Boards which are intended for other applications.

### **A.5.2 Step 2 (long-term load-duration)**

The influence of the load duration under climatic conditions of 30 °C / 95 % r.H. for class X1 boards, under climatic conditions of 60 °C / 95 % r.H. and 90 °C / 30 % r.H. for class X2 boards or 20 °C / 95 % r.H. for class Y boards shall be evaluated according to EN 1156 by application of a static load on the specimen, test-configuration according to EN 1156.

The dimensions of the specimen shall be the same as chosen under step 1.

Based on the results of step 1 (A.4.1 and A.5.1) and step 2 (A.4.2 and A.5.2), considering the evaluation methods of EN 1156, the testing laboratory shall determine  $k_{mod}$  for the service class 1, 2 and 3 according to EN 1995-1-1.

## **A.6 Determination of the creep factor $k_{def}$**

Based on the results of step 1 (A.4.1 and A.5.1) and step 2 (A.4.2 and A.5.2), considering the evaluation methods of EN 1156, clause 7 and the below-mentioned remarks the creep factor  $k_{def}$  shall be determined.

The test results shall be calculated according to EN 1156, clause 7 in consideration of the given remarks.

The creep factor will be determined out of measurements of the displacement at certain points of time. The creep factor will be calculated according to the following formula.

$$k_c = \frac{a_t - a_1}{a_1 - a_0}$$

with:

$a_t$      Total displacement at time  $t$  in [mm]

$a_0$  displacement of the unloaded specimen  
 $a_1 - a_0$  elastic displacement at the point of start, after 1 min.

From the determined  $k_c$  values, you approximate a double logarithmic formula as you can find below.

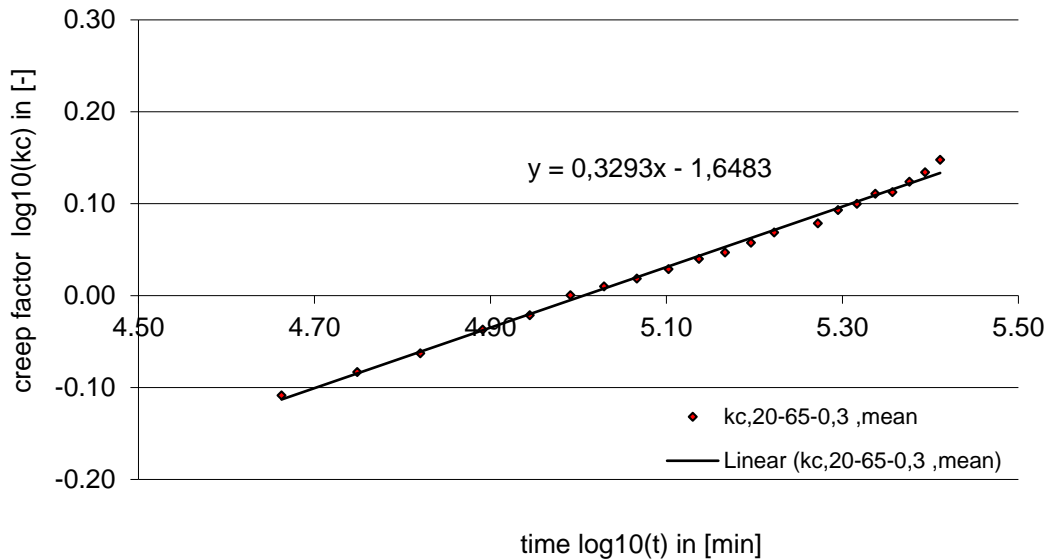

This double logarithmic approximation will be extended to the time periods of the different load duration classes. Those time periods are:

Load duration class (LDC)	Time period
Permanent (50 a)	50 years
Long- term (10 a)	10 years
Medium- term (6 mon.)	6 months
Short- term (7 d)	7 days
Instantaneous (1 min.)	1 minute

The determination of creep will be calculated according to the following formula:

$$k_{c,LDC,SC} = \frac{(a_{c,LDC,SC} - a_{c,1min,SC})}{(a_{c,1min,SC} - a_{c,0min,SC})}$$

For the determination of the Deformation factor the following formula will be used:

$$k_{def,SC} = k_{c,LDC,SC}$$

For determination of the deformation factor for use according to EN 1995-1-1 a time period of permanent (50 a) will be used.

## ANNEX B DETERMINATION OF BENDING STRENGTH, BENDING MODULUS OF ELASTICITY PERPENDICULAR TO THE PLANE AND IN PLANE TO THE PLANE OF THE BOARD AND TYPE OF BENDING BEHAVIOUR PERPENDICULAR TO THE PLANE OF THE BOARD

Version: June 2016

### B.1 References

EN 310	Wood-based panels; determination of modulus of elasticity in bending and of bending strength
EN 789	Timber structures - Test methods - Determination of mechanical properties of wood based panels
EN 12467	Fibre cement flat sheets - Product specification and test methods

### B.2 Scope

This procedure is for the determination of bending strength and bending modulus of elasticity perpendicular to the plane and in plane to the plane.

### B.3 Specimen

The "Product" used for testing shall correspond to the average of the production. From these "Product" 32 perpendicular board strips shall be tested. The cutting edges shall be placed perpendicular to the plane of the board. When cutting the samples a minimum distance of 200 mm off the edge and 100 mm away from the next sample shall be kept.

Dimensions of the specimen  $W \times L \times t$  for testing the bending perpendicular to the plane:

Width	$W$	=	400	[mm]
Length	$L$	=	$l_A + 100$	[mm]
Span	$l_A$	=	$40 \times e$	[mm]
Thickness	$t$			[mm]

Dimensions of the specimen for testing the bending in plane to the plane:

Height	$H$	=	$3 \times e$	[mm]
Length	$L$	=	$l_A + 100$	[mm]
Span	$l_A$	=	$20 \times e$	[mm]
Thickness	$t$			[mm]

The preferred edge length is 250 mm. If the ratio between support distance and deformation at rupture is smaller than 20, then a support distance of  $16 \times$  nominal thickness shall be chosen.

The samples shall be marked.

#### B.4 Storage of the specimens

The specimens shall be stored under climatic conditions (23 °C/50 % r.H.) for 14 days.

#### B.5 Procedure

The procedure for the determination of the bending strength and the bending modulus of elasticity of the cement-bonded board when loading perpendicular to the plane of the board and in plane to the plane of the board is prescribed in the following (in a lot of details the procedure agrees with the test procedure of EN 310).

The board strips are placed in a bending test machine (see Figure B.1) on which the load of the strip acting as test load shall be placed in the middle of the span and depending on the production direction placed parallel or perpendicular to the production direction.

The load  $F$  shall be applied with constant rate, maximum load shall be reached in  $300 \text{ s} \pm 120 \text{ s}$ . The load/deformation graphs shall be plotted.

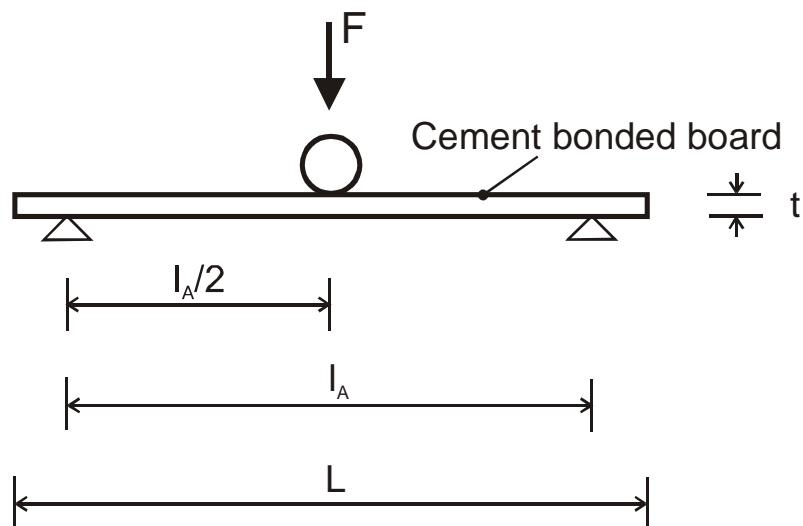

Diameter of the load applying roll:  $d = 30 \text{ mm}$

Diameter of the bearing rolls:  $d = 15 \text{ mm}$

**Figure B.1:** Bending test machine

The bending test shall be carried out under climatic conditions (23 °C/ 50% r.H.).

## B.6 Expression of results

### B.6.1 Type of bending behaviour for the loading perpendicular to the plane of the board

The type of bending behaviour depends on the form of the load/deformation graphs (see Figures B.2a and B.2b).

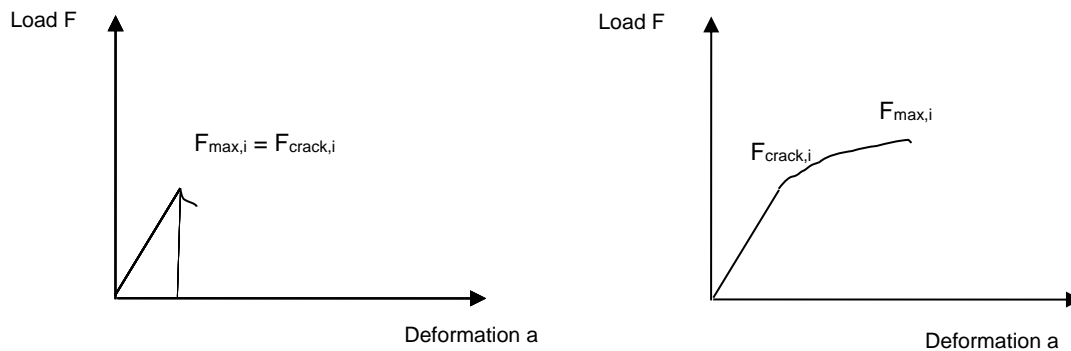

$F_{max,i}$  is equal to the load at the first crack  $F_{crack,i}$

$F_{max,i}$  is higher than the load at the first crack  $F_{crack,i}$

**Figure B.2a:** Brittle bending behaviour

**Figure B.2b:** Ductile bending behaviour

The brittle bending behaviour is typical for cement-bonded boards with randomly distributed short glass fibres and the ductile bending behaviour is typical for cement-bonded boards with continuous strands, tapes, nets or webs.

Normally the bending behaviour for the bending in the plane of the plane is brittle in every case.

### B.6.2 Bending strength

The bending strength  $f_{m,90,k}$  for the bending perpendicular to the plane is given by the formula:

$$f_{m,90,k} = \frac{3 \times F_{max,k} \times l_A}{2 \times b \times t^2} \text{ and}$$

the bending strength  $f_{m,0,k}$  for the bending in plane to the plane is given by the formula:

$$f_{m,0,k} = \frac{F_{max,k} \times l_A}{6 \times t^3}$$

where:

- $F_{max,k}$  = 5 % quantile with 75 % confidence level (see EN 14358) of all breaking loads  $F_{max,i}$  in Newton
- $l_A$  = span between the axes of support in mm
- $w$  = width of the test specimen in mm
- $t$  = thickness in mm
- $f_{m,90,k}$  = characteristic value of bending strength of the tests perpendicular to the plane
- $f_{m,0,k}$  = characteristic value of bending strength of the tests in plane to the plane

The characteristic value  $f_{m,90,k}$  and the characteristic value  $f_{m,0,k}$  shall be given in the ETA. It is sufficient to consider the first three digits of the calculated characteristic values. If there are more than three digits before decimal point the fourth until last digit before decimal point may be replaced by 0. If the third digit is behind decimal point further digits may be neglected.

### B.6.3 Bending modulus of elasticity for brittle bending behaviour

Using data obtained from the local modulus of elasticity test, plot the load/deformation graph.

Use that section of graph between  $0,1 F_{\max,i}$  and  $0,4 F_{\max,i}$  for the regression analysis.

Find the longest portion of this section that gives a correlation of 0,99 or better. Provided that this proportion covers at least the range  $0,2 F_{\max,i}$  to  $0,3 F_{\max,i}$  calculate the bending modulus of elasticity  $E_{m,i,90}$  for the bending perpendicular to the plane from the following formula:

$$E_{m,i,90} = \frac{l_A^3 \times (F_{2,i} - F_{1,i})}{4 \times b \times t^3 \times (a_{2,i} - a_{1,i})} \text{ and}$$

the bending modulus of elasticity  $E_{m,i,0}$  for the bending in plane to the plane from the following formula:

$$E_{m,i,0} = \frac{l_A^3 \times (F_{2,i} - F_{1,i})}{108 \times t^4 \times (a_{2,i} - a_{1,i})}$$

where:

$l_A$  = span between the axes of support in mm

$b$  = width of the test specimen in mm

$t$  = thickness in mm

$F_{2,i} - F_{1,i}$  = increment of load in Newton on the regression line with a correlation coefficient of 0,99 or better of the specimen  $i$

$a_{2,i} - a_{1,i}$  = increment of deformation in mm corresponding to  $F_{2,i} - F_{1,i}$ , see Figure B.2 of the specimen

$E_{m,i,90}$  = bending modulus of elasticity of the specimen in perpendicular to the plane

$E_{m,i,0}$  = bending modulus of elasticity of the specimen in plane of the plane

If the portion of the graph can not be found with a correlation coefficient of 0,99 or better covering the range  $0,2 F_{\max,i}$  to  $0,3 F_{\max,i}$  check the test equipment and take measures to eliminate errors caused by distorted specimens. If 0,99 is still not achieved, discard specimen.

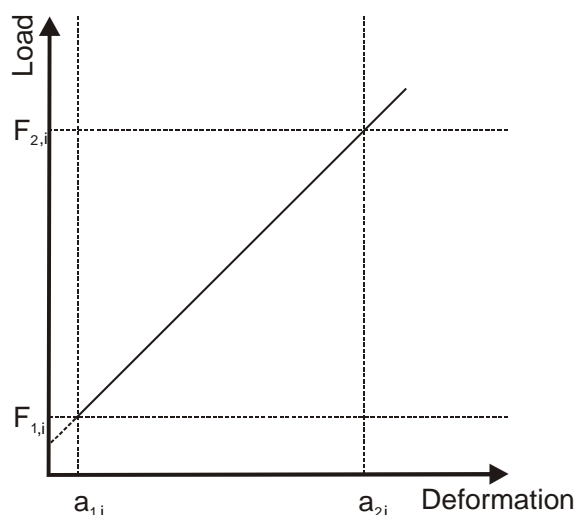

Figure B.3: Load-deformation graph within the range of elastic deformation

The average value  $E_{m,90,mean}$  of all values  $E_{m,i,90}$  and the average value  $E_{m,0,mean}$  of all values  $E_{m,i,0}$  shall be given in the ETA. It is sufficient to consider the first three digits of the calculated average values. If there are more than three digits before decimal point the fourth until last digit before decimal point may be replaced by 0. If the third digit is behind decimal point further digits shall be neglected.



#### B.6.4 Bending modulus of elasticity for ductile bending behaviour for loading perpendicular to the plane

Since the behaviour after the first crack is nonlinear it is recommendable to use two modulus of elasticity. One is for the calculation of the **stresses** and one is for the calculations of **deformations**.

The first one ( $E_{m,90, \text{stress}}$ ) may be calculated by the procedure of B.6.3 replacing  $F_{\text{max},i}$  by  $F_{\text{crack},i}$ . The average value  $E_{m,90, \text{stress}}$  of all values  $E_{m,i,90, \text{stress}}$  and the average value  $E_{m,90, \text{stress}, \text{mean}}$  shall be given in the ETA. For the evaluation of the results see also clause B.6.3.

The second bending modulus of elasticity ( $E_{m,90, \text{def}}$ ) shall be calculated by the following formula:

$$E_{m,90, \text{def}} = \frac{l_A^3 \times F_{\text{max},k}}{4 \times b \times t^3 \times a_{k,m}}$$

where:

- $F_{\text{max},k}$  = 5 % quantile with 75 % confidence level (see EN 14358) of all breaking loads  $F_{\text{max},i}$  (see clause B.6.2),
- $a_{k,m}$  = average value of all deformations  $a_{k,i}$
- $a_{k,i}$  = deformation at the load  $F_{\text{max},k}$  derived from the load/deformation graph of the specimen number  $i$  of the tests perpendicular to plane
- $l_A$  = span between the axes of support in mm
- $b$  = width of the test specimen in mm
- $t$  = thickness in mm

It is sufficient to consider the first three digits of the calculated value. If there are more than three digits before decimal point the fourth until last digit before decimal point may be replaced by 0. If the third digit is behind decimal point further digits may be neglected.

The average value  $E_{m,90, \text{def}}$  of all values  $E_{m,i,90, \text{def}}$  and the average value  $E_{m,90, \text{def}, \text{mean}}$  shall be given in the ETA.

Deviations from this recommendation shall be prescribed and justified in the evaluation report.

## **ANNEX C REACTION TO FIRE – MOUNTING AND FIXING CONDITIONS FOR TESTING ACCORDING TO EN 13823**

### **C.1 General**

The product may be used for non-structural internal and external walls, as lining, and for the manufacture of floor construction elements and also for structural applications for the planking and lining of walls, for stiffening timber or steel framed walls, ceilings and roof truss structures.

### **C.2 Test specimen**

Products used for the construction of the test assembly are cement-bonded boards with standard dimensions of length, width and thickness. They are cut to size to accommodate the dimensions of the test assembly. They include all facings and/or coatings that are intended to be applied to the product as it is placed on the market. Products have to be tested with minimum and maximum thickness and minimum and maximum density.

### **C.3 Test assembly**

For end use situations with an air gap or ventilated air gap the product shall be mounted on a wooden or metallic frame. The wooden frame are made of wood strips ( $40 \pm 1$ ) mm x ( $40 \pm 1$ ) mm for vertical members and ( $20 \pm 1$ ) mm x ( $40 \pm 1$ ) mm for horizontal members. They are nailed or screwed together. To ensure a ventilated air gap there has to be a joint of 10 mm between u-profile of the test device and the bottom of the cement-bonded boards.

### **C.4 Substrates**

The product has to be fixed mechanically with screws as used in end use on to the substrat. Standard substrates shall meet the requirements of EN 13238.

For end use situations with an air gap or ventilated air gap it is required that specimens have to have a distance between backside and substrate of at least 40 mm and if required with a smaller air gap. Both distances have to be tested and the worst indicative test has to be considered for classification. The space between test rig backing board and backside of the supporting frame shall be filled with mineral wool insulation with a nominal thickness of 50 mm, a nominal density of ( $70 \pm 20$ ) kg/m<sup>3</sup> and a class A2-s1,d0 according to EN 13501-1. The thermal insulation is embedded between the frames and the test rig backing board.

### **C.5 Joints**

Product applied with horizontal and/or vertical joints shall be tested with a horizontal joint in the long wing at a height of 500 mm from the bottom edge of the specimen and/or with a vertical joint in the long wing at a distance of 200 mm from the corner line, measured when the wings are mounted ready for testing. The maximum opening width has to be tested.

### **C.6 Product orientation**

Products with identical surface finishes on both sides have to be tested at one side only. Products with different surface finishes or coatings on different sides shall be tested on both sides or with the side representative for the worst performance directed to the fire. The worst performance is normally obtained with the side having the finish with the highest organic content per m<sup>2</sup> surface and the darkest colour. The side with the highest organic content shall be derived from the composition of the different finishing layers or by determining their gross calorific value according to EN ISO 1716, taking account of the respective applied dry weights of the finishing layers.

### **C.7 Field of application for the obtained classification**

The classification also applies to cement-bonded board of the same mix formulation for the base sheet:

- of the same type, but with different dimensions of length and width;
- with a density range between the highest and lowest density tested;
- with a thickness range between the highest and lowest thickness tested;
- with a joint opening width equal to or smaller than those used for the test;
- fixed with all other types of mechanical devices such as metal (excluding aluminium) nails or rivets;
- products tested on wooden frames can also be used on metallic profiles;
- products tested on metallic frames can only be used on metallic profiles;
- with a different surface texture (smooth or embossed);
- fixed at different (wider or closer) horizontal or vertical fixing centres;
- without thermal insulation in the cavity or with other types of class A2-s1,d0 according to EN 13501-1 insulation materials as long as a ventilated air gap of at least  $(40 \pm 1)$  mm directly behind the sheets is present;
- without finishes or with different finishes or coatings (e.g. different colours) as long as the test was performed considering the worst case as explained in C.5.

In cases where EDPM jointing strip has been used the result is also valid for other jointing material for a similar or higher fire classification.