

EUROPEAN ASSESSMENT DOCUMENT

EAD 340179-00-0203

December 2018

STRUCTURAL PANELLED BUILDING KIT

The reference title and language for this EAD is English. The applicable rules of copyright refer to the document elaborated in and published by EOTA.

This European Assessment Document (EAD) has been developed taking into account up-to-date technical and scientific knowledge at the time of issue and is published in accordance with the relevant provisions of Regulation (EU) No 305/2011 as a basis for the preparation and issuing of European Technical Assessments (ETA).

Contents

1	Scope of the EAD.....	4
1.1	Description of the construction product	4
1.2	Information on the intended use(s) of the construction product	5
1.2.1	Intended use(s).....	5
1.2.2	Working life/Durability.....	5
2	Essential characteristics and relevant assessment methods and criteria.....	6
2.1	Essential characteristics of the product	6
2.2	Methods and criteria for assessing the performance of the product in relation to essential characteristics of the product	7
2.2.1	Shear strength and shear modulus of the panel	7
2.2.2	Creep coefficient of the panel.....	8
2.2.3	Compression strength at 10 % of deformation of the core.....	8
2.2.4	Reduced long term shear strength of the core.....	8
2.2.5	Tensile strength and tensile modulus perpendicular to the faces of the panel	9
2.2.6	Tensile strength and tensile modulus perpendicular to the faces of the panel at elevated temperatures	9
2.2.7	Bending moment and wrinkling stress in span and at central support of the panel.....	10
2.2.8	Compression strength and compression strength combined with lateral force of the panel	10
2.2.9	Resistance to point loads and access loads of the panel	11
2.2.10	Crushing strength of the wall to floor joint of the panel	11
2.2.11	Shear strength perpendicular to the panels' face of the panel lock system.....	11
2.2.12	Shear strength parallel to the panels' face of the panel lock system	12
2.2.13	Tensile strength of the panel lock system	12
2.2.14	Shear strength of the panel lock system with profile.....	12
2.2.15	Tensile strength of the panel lock system with profile.....	12
2.2.16	Combined tensile and shear strength of all type of connections.....	13
2.2.17	Racking resistance of wall panel assemblies.....	13
2.2.18	Reduced long term tensile strength because of ageing	13
2.2.19	Reaction to fire	14
2.2.20	Water vapour permeability and moisture resistance	14
2.2.21	Water permeability	15
2.2.22	Impact resistance	15
2.2.23	Thermal resistance / conductivity	16
2.2.24	Air permeability.....	16
3	Assessment and verification of constancy of performance	17
3.1	System(s) of assessment and verification of constancy of performance to be applied	17
3.2	Tasks of the manufacturer	17
3.3	Tasks of the notified body	18
3.4	Special methods of control and testing used for the verification of constancy of performance	19
3.4.1	Density of the core material.....	19
3.4.2	Tensile strength and thickness of the face material	19
3.4.3	Dimensions of the panel.....	20
3.4.4	Thermal conductivity of the core material	20
3.4.5	Materials of the panel lock system	20
4	Reference documents	21
	Annex A – Test methods.....	22
	Annex B – Description of the kit and its components.....	44

1 SCOPE OF THE EAD

1.1 Description of the construction product

Structural panelled building kit, hereinafter called building kit, composed of metal face PUR¹ structural sandwich panels connected on site to each other by means of an interlocking system based on a rotating steel hook contained in the panel that locks on a steel axis contained in the second panel and clamps the two panels together.

Metal faces of the panel are made of steel sheets according to EN 10346². The density of the core material is given in Annex B.

The range of possible dimensions of wall, ceiling, floor and corner panels as well as the description of the kit and its components is given in Annex B. This EAD covers panels within a wide range of dimensions. Further description of the kit and its components is given in Annex B.

The building kit is composed of:

- Floor panels fully supported on foundation layer (the foundation is not part of the kit).
- Loadbearing wall panels with no loadbearing structure other than ancillary profiles in the junctions between panels.
- Non-loadbearing wall panels with the same interlocking system than the loadbearing wall panels. Non-loadbearing wall panels connect to floors or ceilings through a profile.
- Loadbearing ceiling panels supported on walls. In case the building needs a pitched roof, this pitch is provided by inclined roof panels supported on vertical panels lean on ceiling panels.
- Metallic or wood profiles (base profiles, corner profiles, windows and doors profiles) and junctions.

According to the building kit composition, two types of systems are identified:

- Kit with floor panels.
- Kit without floor panels. In this case, the wall panels will be connected to the foundation through a profile.

The width of the openings (doors, windows, etc.) is the same as the width of the panel(s). The openings have a perimetric wood frame.

Polyethylene or polystyrene strips are used in the joint between panels.

Only the whole kit can be CE marked. The kit components are not to be CE market separately and not to be placed on the market separately from the kit.

The product is not fully covered by the following technical specifications:

- EN 14509. This standard covers self-supporting panels and the EAD covers the load-bearing kit made of panels. Most of the assessment methods for the panel of EN 14509 apply to his product. The applicable assessment methods are referred to in the relevant clauses of this EAD. EN 14509 does not include the assessment of the loadbearing behaviour of the panels, nor of the kit, nor of the connections.
- ETAG 23 of August 2006: The ETAG covers prefabricated building units, designed as box-like structures, assembled in a factory and transportable to site in flat-pack or three-dimensional format. The building units covered by ETAG 23 become a building (singly or in combination), whilst individual panels covered by this EAD are used to build any kind of building in situ. The EAD covers a building kit

¹ Polyurethane (PUR) includes polyisocyanurate (PIR).

² All undated references to standards or to EADs in this EAD are to be understood as references to the dated versions listed in clause 4.

whose structural components are assembled on site and transportable to site in several packages of panels.

Concerning product packaging, transport, storage, maintenance, replacement and repair it is the responsibility of the manufacturer to undertake the appropriate measures and to advise his clients on the transport, storage, maintenance, replacement and repair of the product as he considers necessary.

It is assumed that the product will be installed according to the manufacturer's instructions or (in absence of such instructions) according to the usual practice of the building professionals.

Relevant manufacturer's stipulations having influence on the performance of the product covered by this European Assessment Document shall be considered for the determination of the performance and detailed in the ETA.

1.2 Information on the intended use(s) of the construction product

1.2.1 Intended use(s)

Structural panelled building kit for the construction of one storey buildings.

The kit allows for the construction of the building structure, which is also the building shuttering, the kit does not include finishings, either internal or external.

1.2.2 Working life/Durability

The assessment methods included or referred to in this EAD have been written based on the manufacturer's request to take into account a working life of the structural panelled building kit for the intended use of 50 years for the loadbearing and non-loadbearing structure when installed in the works. These provisions are based upon the current state of the art and the available knowledge and experience.

When assessing the product the intended use as foreseen by the manufacturer shall be taken into account. The real working life may be, in normal use conditions, considerably longer without major degradation affecting the basic requirements for works³.

The indications given as to the working life of the construction product cannot be interpreted as a guarantee neither given by the product manufacturer or his representative nor by EOTA when drafting this EAD nor by the Technical Assessment Body issuing an ETA based on this EAD but are regarded only as a means for expressing the expected economically reasonable working life of the product.

³ The real working life of a product incorporated in a specific works depends on the environmental conditions to which that works is subject, as well as on the particular conditions of the design, execution, use and maintenance of that works. Therefore, it cannot be excluded that in certain cases the real working life of the product may also be shorter than referred to above.

2 ESSENTIAL CHARACTERISTICS AND RELEVANT ASSESSMENT METHODS AND CRITERIA

2.1 Essential characteristics of the product

Table 2.1.1 shows how the performance of the structural panelled building kit is assessed in relation to the essential characteristics.

Table 2.1.1: Essential characteristics of the product and methods and criteria for assessing the performance of the product in relation to those essential characteristics.

No	Essential characteristic	Assessment method	Type of expression of product performance
Basic Works Requirement 1: Mechanical resistance and stability			
1	Shear strength and shear modulus of the panel	2.2.1	Level
2	Creep coefficient of the panel	2.2.2	Level
3	Compression strength at 10 % of deformation of the core	2.2.3	Level
4	Reduced long term shear strength of the core	2.2.4	Level
5	Tensile strength and tensile modulus perpendicular to the faces of the panel	2.2.5	Level
6	Tensile strength and tensile modulus perpendicular to the faces of the panel at elevated temperatures	2.2.6	Level
7	Bending moment and wrinkling stress in span and at central support of the panel	2.2.7	Level
8	Compression strength and compression strength combined with lateral force of the panel	2.2.8	Level
9	Resistance to point loads and access loads of the panel	2.2.9	Level
10	Crushing strength of the wall to floor joint of the panel	2.2.10	Level
11	Shear strength perpendicular to the panels' face of the panel lock system	2.2.11	Level
12	Shear strength parallel to the panels' face of the panel lock system	2.2.12	Level
13	Tensile strength of the panel lock system	2.2.13	Level
14	Shear strength of the panel lock system with profile	2.2.14	level
15	Tensile strength of the panel lock system with profile	2.2.15	Level
16	Combined tensile and shear strength of all type of connections	2.2.16	Level
17	Racking resistance of wall panel assemblies	2.2.17	Level
18	Reduced long term tensile strength because of ageing ⁴	2.2.18	Description

⁴ This essential characteristic is related to aspects of durability linked to the essential characteristic num. 5: Tensile strength and tensile modulus perpendicular to the faces of the panel.

No	Essential characteristic	Assessment method	Type of expression of product performance
Basic Works Requirement 2: Safety in case of fire			
19	Reaction to fire	2.2.19	Class
Basic Works Requirement 3: Hygiene, health and the environment			
20	Water vapour permeability and moisture resistance	2.2.20	Level
21	Water permeability	2.2.21	Class
Basic Works Requirement 4: Safety and accessibility in use			
22	Impact resistance	2.2.22	Level
Basic Works Requirement 6: Energy economy and heat retention			
23	Thermal resistance / conductivity	2.2.23	Level
24	Air permeability	2.2.24	Level

2.2 Methods and criteria for assessing the performance of the product in relation to essential characteristics of the product

This chapter is intended to provide instructions for TABs. Therefore, the use of wordings such as “shall be stated in the ETA” or “it has to be given in the ETA” shall be understood only as such instructions for TABs on how results of assessments shall be presented in the ETA. Such wordings do not impose any obligations for the manufacturer and the TAB shall not carry out the assessment of the performance in relation to a given essential characteristic when the manufacturer does not wish to declare this performance in the Declaration of Performance.

Testing will be limited only to the essential characteristics which the manufacturer intends to declare. If for any components covered by harmonised standards or European Technical Assessments the manufacturer of the component has included the performance regarding the relevant characteristic in the Declaration of Performance, retesting of that component for issuing the ETA under the current EAD is not required.

When the product performance is expressed by the mean value and the 5 %-fractile value with a confidence level of 75 % using a log-normal distribution of the population of test results, then these values shall be determined according to ISO 12491.

2.2.1 Shear strength and shear modulus of the panel

Purpose of the assessment

The assessment is required to provide the shear strength and shear modulus of the panel.

Assessment method

The shear strength (f_{cv}) and shear modulus (G_c) of the panel shall be determined in accordance with clause A.3 of annex A of EN 14509.

Minimum number of specimens to be tested for the defined range of thickness: 3 specimens of the minimum thickness, 3 specimens of the intermediate thickness and 3 specimens of the maximum thickness.

Expression of results

The mean value and the 5 %-fractile value with a confidence level of 75 % using a log-normal distribution of the shear strength of the panel shall be expressed in the ETA by means of a level.

The mean value of the shear modulus of the panel shall be expressed in the ETA by means of a level.

2.2.2 Creep coefficient of the panel

Purpose of the assessment

The assessment is required to provide the creep coefficient of panels used for floors and roofs.

Assessment method

The creep coefficient of the panel (φ_t) shall be determined in accordance with clause A.6 of annex A of EN 14509 or taken from tabulated values for rigid foams of clause E.7.6 of EN 14509.

The creep coefficient of the panel is to be determined only for panels used for floors and roofs.

If the testing procedure is used, then one specimen shall be tested. The thickest panel in the defined range must be tested.

Expression of results

The creep coefficient of the panel shall be expressed in the ETA by means of a level.

2.2.3 Compression strength at 10 % of deformation of the core

Purpose of the assessment

The assessment is required to provide the compression strength at 10 % of deformation of the core.

Assessment method

The compression strength at 10 % of deformation of the core (σ_{10}) shall be determined in accordance with clause A.2 of annex A of EN 14509. The calculation of the compression strength at 10 % of deformation is specified in clause 8.3 of EN 826.

Minimum number of specimens to be tested for the specified range of thicknesses: 6 specimens of the minimum thickness, 6 specimens of the intermediate thickness and 6 specimens of the maximum thickness.

The specimens shall have a square cross section. The dimensions of the square shall be selected from the proposed dimensions in clause 6.1 of EN 826. The size of the square shall not be less than its thickness.

Expression of results

The mean value and the 5 %-fractile value with a confidence level of 75 % using a log-normal distribution of the compression strength at 10 % of deformation of the core shall be expressed in the ETA by means of a level.

The mean value of the compression modulus of the panel shall be expressed in the ETA by means of a level.

2.2.4 Reduced long term shear strength of the core

Purpose of the assessment

The assessment is required to provide the reduced long term shear strength of the core for panels used for floors and roofs.

Assessment method

The reduced long-term shear strength of the core (f_{cv} long term) shall be determined in accordance with clause A.3.6 of annex A of EN 14509. The characteristic can be determined by calculation (clause A.3.6.1 of EN 14509) or by testing (clauses A.3.6.2 and A.3.6.3 of EN 14509). If the testing procedure is chosen, at least ten specimens of the same dimensions shall be tested.

The reduced long-term shear strength of the core is to be determined for panels used for floors and roofs.

Expression of results

The mean value and the 5 %-fractile value with a confidence level of 75 % using a log-normal distribution of the reduced long-term shear strength of the core shall be expressed in the ETA by means of a level.

2.2.5 Tensile strength and tensile modulus perpendicular to the faces of the panel

Purpose of the assessment

The assessment is required to provide the tensile strength and tensile modulus perpendicular to the faces of the panel.

Assessment method

The tensile strength (f_{ct}) and tensile modulus (E_{ct}) perpendicular to the faces of the panel shall be determined in accordance with clause A.1 of annex A of EN 14509.

Minimum number of specimens to be tested for the specified range of thickness: 6 specimens of the minimum thickness, 6 specimens of the intermediate thickness and 6 specimens of the maximum thickness.

The specimens shall have a square cross section. The size of the square shall be between 100 mm and 300 mm.

Expression of results

The mean value and the 5 %-fractile value with a confidence level of 75 % using a log-normal distribution of the tensile strength and the mean value of the tensile modulus perpendicular to the faces of the panel shall be expressed in the ETA by means of a level.

The 5 %-fractile of the tensile strength perpendicular to the faces of the panel is to be higher than 0,018 MPa, according to clause 5.2.1.6 of EN 14509.

2.2.6 Tensile strength and tensile modulus perpendicular to the faces of the panel at elevated temperatures

Purpose of the assessment

The assessment is required to provide the tensile strength and tensile modulus perpendicular to the faces of panels used in external uses at elevated temperatures.

Assessment method

The tensile strength (f_{ct}) and tensile modulus (E_{ct}) perpendicular to the faces of the panel at elevated temperatures shall be determined in accordance with clause A.1.6 of annex A of EN 14509.

The tensile strength and tensile modulus perpendicular to the faces of the panel at elevated temperatures is to be determined for panels used in external uses.

Minimum number of specimens to be tested for the specified range of thickness: 3 specimens of the minimum thickness, 3 specimens of the intermediate thickness and 3 specimens of the maximum thickness.

Expression of results

The mean value and the 5 %-fractile value with a confidence level of 75 % using a log-normal distribution of the tensile strength and the mean value of the tensile modulus perpendicular to the faces of the panel shall be expressed in the ETA by means of a level.

2.2.7 Bending moment and wrinkling stress in span and at central support of the panel

Purpose of the assessment

The assessment is required to provide the bending moment and wrinkling stress in span and at central support of the panel.

Assessment method

a) In span:

The bending strength (M_u) of the panel shall be determined in accordance with the testing procedure of clause A.5 of EN 14509.

Minimum number of specimens to be tested for the specified range of thickness: 3 specimens of the minimum thickness, 3 specimens of the intermediate thickness and 3 specimens of the maximum thickness.

The wrinkling stress (σ_w) of the panel shall be determined in accordance with the calculation procedure of clause A.5.5 of EN 14509, based on the bending strength test results, or alternatively can be calculated according to equation A.20 of EN 14509.

b) At central support:

The bending strength (M_u) of the panel shall be determined in accordance with the testing procedure of clause A.7 of EN 14509.

Minimum number of specimens to be tested for the specified range of thickness: 3 specimens of the minimum thickness, 3 specimens of the intermediate thickness and 3 specimens of the maximum thickness.

The tests simulate the load upwards and downwards applied on the middle of a panel. The conditions of the central support to be applied will simulate the actual conditions of the system.

The wrinkling stress (σ_w) of the panel shall be determined in accordance with the calculation procedure of clause A.5.5 of EN 14509, based on the bending strength test results, or alternatively can be calculated according to equation A.20 of EN 14509.

Expression of results

The mean value and the 5 %-fractile value with a confidence level of 75 % using a log-normal distribution of the bending strength and wrinkling stress in span and at central support of the panel shall be expressed in the ETA by means of a level.

2.2.8 Compression strength and compression strength combined with lateral force of the panel

Purpose of the assessment

The assessment is required to provide the compression strength and compression strength combined with lateral force of loadbearing panels.

Assessment method

The compression strength and compression strength combined with lateral force of the panel shall be determined in accordance with annex A.1.1 and A.1.2 of this EAD, respectively.

Only loadbearing panels must be tested.

Expression of results

The mean value and the 5 %-fractile value with a confidence level of 75 % using a log-normal distribution of the compression strength, and the compression strength combined with lateral force of the panel shall be expressed in the ETA by means of a level.

Additionally, the compression strength combined with lateral force of the panel shall be expressed by means of a graph in the ETA.

2.2.9 Resistance to point loads and access loads of the panel

Purpose of the assessment

The assessment is required to provide the safety and serviceability of the panels used for floors and roofs by means of the resistance to point loads and access loads.

Assessment method

According to EN 14509, the resistance to point loads and access loads of the panel is to be determined for panels used for floors and roofs. The resistance to point loads assesses the safety and serviceability of the panels to, for instance, the traffic of a person on the panel during and after the installation. The resistance to access loads assesses the safety and serviceability of the panels to, for instance, a repetitive access during and after the installation.

a) Resistance to point loads

This characteristic shall be determined in accordance with clause A.9.1 of EN 14509.

Minimum number of specimens to be tested for the specified range of thickness: 1 specimen of the minimum thickness, 1 specimen of the intermediate thickness and 1 specimen of the maximum thickness.

b) Resistance to access loads

This characteristic shall be determined in accordance with clause A.9.2 of EN 14509.

Minimum number of specimens to be tested for the specified range of thickness: 1 specimen of the minimum thickness, 1 specimen of the intermediate thickness and 1 specimen of the maximum thickness.

Expression of results

The resistance to point loads shall be expressed in the ETA by means of a level.

The resistance to access loads of the panel shall be expressed in the ETA by means of a level.

2.2.10 Crushing strength of the wall to floor joint of the panel

Purpose of the assessment

The assessment is required to provide the crushing strength of the wall to floor joint of the panel.

Assessment method

The crushing strength of the wall to floor joint of the panel shall be determined in accordance with annex A.2 of this EAD.

Expression of results

The crushing strength of the wall to floor joint of the panel shall be expressed in the ETA by means of a level.

2.2.11 Shear strength perpendicular to the panels' face of the panel lock system

Purpose of the assessment

The assessment is required to provide the shear strength perpendicular to the panel's face of the panel lock system.

Assessment method

The shear strength perpendicular to the panels' face of the panel lock system shall be determined in accordance with annex A.3 of this EAD.

This characteristic is equivalent to the shear strength of the corner lock system.

Expression of results

The shear strength perpendicular to the panels' face of the panel lock system shall be expressed in the ETA by means of a level.

2.2.12 Shear strength parallel to the panels' face of the panel lock system

Purpose of the assessment

The assessment is required to provide the shear strength parallel to the panel's face of the panel lock system.

Assessment method

The shear strength parallel to the panels' face of the panel lock system shall be determined in accordance with annex A.4 of this EAD.

Expression of results

The shear strength parallel to the panels' face of the panel lock system shall be expressed in the ETA by means of a level.

2.2.13 Tensile strength of the panel lock system

Purpose of the assessment

The assessment is required to provide the tensile strength of the panel lock system.

Assessment method

The tensile strength of the panel lock system shall be determined in accordance with annex A.5 of this EAD.

Expression of results

The tensile strength of the panel lock system shall be expressed in the ETA by means of a level.

2.2.14 Shear strength of the panel lock system with profile

Purpose of the assessment

The assessment is required to provide the shear strength of the panel lock system with profile.

Assessment method

The shear strength of the panel lock system with profile shall be determined in accordance with annex A.6 of this EAD.

Expression of results

The shear strength of the panel lock system with profile shall be expressed in the ETA by means of a level.

2.2.15 Tensile strength of the panel lock system with profile

Purpose of the assessment

The assessment is required to provide the tensile strength of the panel lock system with profile.

Assessment method

The tensile strength of the panel lock system with profile shall be determined in accordance with annex A.7 of this EAD.

Expression of results

The tensile strength of the panel lock system with profile shall be expressed in the ETA by means of a level.

2.2.16 Combined tensile and shear strength of all type of connections

Purpose of the assessment

The assessment is required to provide the combined tensile and shear strength of all type of connections.

Assessment method

The combined tensile and shear strength of all type of connections shall be determined in accordance with annex A.8 of this EAD.

Expression of results

The combined tensile and shear strength of all type of connections shall be expressed in the ETA by means of a level.

2.2.17 Racking resistance of wall panel assemblies

Purpose of the assessment

The assessment is required to provide the racking resistance of wall panel assemblies.

Assessment method

The racking resistance of wall panel assemblies shall be determined in accordance with annex A.9 of this EAD.

Expression of results

The racking resistance, expressed by the racking stiffness and the racking strength, of wall panel assemblies shall be expressed in the ETA by means of a level.

2.2.18 Reduced long term tensile strength because of ageing

Purpose of the assessment

The assessment is required to provide the reduced long term tensile strength because of ageing for external panels.

Assessment method

The reduced long term tensile strength because of ageing shall be determined in accordance with annex B of EN 14509.

PUR panels using blowing agents and their combinations included in EN 13165, but excluding blowing agents with CO₂, are considered to satisfy the characteristic of reduced long term tensile strength because of ageing without testing, in accordance with clause 5.2.3.1 of EN 14509.

The reduced long term tensile strength because of ageing is only determined for external panels.

The ageing program to be used is DUR1 according to table 3 of EN 14509. The effect of the ageing on the panel must be measured by the determination of the change in the tensile strength perpendicular to the faces of the panel according to EN 1607, on specimens submitted to an ageing program DUR1.

The ageing temperature shall be selected among those indicated in the clause B.2.1 of annex B of EN 14509 depending on the reflectance of the colour of the exposed face (see clause E.3.3 of EN 14509).

The maximum and the minimum thickness of the range must be tested. The specimens will have a square cross section (100 mm x 100 mm).

The tensile strength perpendicular to the faces will be tested according to clause A.1 of annex A of EN 14509 with the following approach:

- 6 specimens without ageing.
- 1 set of 5 specimens previously submitted to the selected ageing temperature for 42 days.
- 1 set of 5 specimens previously submitted to the selected ageing temperature for 84 days.

The assessment criteria of clause B.2.5 of annex B will be applied.

Expression of results

The reduced long term tensile strength because of ageing shall be expressed in the ETA by means of a description.

2.2.19 Reaction to fire

Purpose of the assessment

The assessment is required to provide the reaction to fire of the relevant parts of the structural panelled building kit.

Assessment method

The structural panelled building kit shall be tested, using the test method(s) referred to in EN 13501-1 and relevant for the corresponding reaction to fire class. The product shall be classified according to Commission Delegated Regulation (EU) No 2016/364.

Additional instructions (specimens, mounting and fixing, etc.) for testing and extended applications according to clause C.1 of EN 14509 shall be used.

Expression of results

The reaction to fire of the relevant parts of the structural building kit shall be expressed in the ETA by means of a class.

2.2.20 Water vapour permeability and moisture resistance

Purpose of the assessment

The assessment is required to provide the vapour permeability properties of the relevant layers of the panel.

Assessment method

Due to the metallic nature of the faces, according to the criterion established in clause 5.2.8 of EN 14509, the panels are considered as water vapour tight.

The water vapour permeability properties of sealants or gaskets shall be obtained from the tabulated values defined in EN ISO 10456.

Expression of results

The water vapour permeability properties shall be expressed in the ETA by means of a level.

2.2.21 Water permeability

Purpose of the assessment

The assessment is required to provide the water permeability of external walls and roofs.

Assessment method

The water permeability is only relevant for panels which contribute to the watertightness (external walls and roofs).

The water permeability shall be determined according to clause 5.2.6 of EN 14509 on a specimen made of all the components of the envelope which are part of the kit. The testing procedure of clause A.11 of Annex A of EN 14509 will be used.

Expression of results

The water permeability shall be expressed in the ETA by means of a class.

2.2.22 Impact resistance

Purpose of the assessment

The assessment is required to provide the impact resistance of wall or floors assemblies regarding safety in use and serviceability.

Assessment method

The impact resistance of wall or floors assemblies is split into the following characteristics:

a) Safety in use:

- Resistance to structural damage from soft body impact load – 50 kg

The resistance to structural damage from soft body impact load shall be determined in accordance with the clause 2.2.5.1 of EAD 210005-00-05.05.

- Resistance to structural damage from hard body impact load – 1 kg

The resistance to structural damage from hard body impact load shall be determined in accordance with the clause 2.2.5.2 of EAD 210005-00-05.05.

This characteristic depends on the surface layer of the wall or floor. If the surface layer is not part of the kit, then this characteristic is not of relevance.

b) Serviceability:

- Resistance to functional failure from soft body impact load – 50 kg

The resistance to functional failure from soft body impact load shall be determined in accordance with the clause 2.2.5.1 of EAD 210005-00-05.05.

- Resistance to functional failure from hard body impact load – 0,5 kg

The resistance to functional failure from hard body impact load shall be determined in accordance with the clause 2.2.5.2 of EAD 210005-00-05.05.

This characteristic depends on the surface layer of the wall or floor. If the surface layer is not part of the kit, then this characteristic is not of relevance.

Expression of results

a) Safety in use:

- Resistance to structural damage from soft body impact load – 50 kg

The resistance to structural damage from soft body impact load shall be expressed in the ETA by means of a level according to clause 2.2.5.1 of EAD 210005-00-05.05.

- Resistance to structural damage from hard body impact load – 1 kg

The resistance to structural damage from hard body impact load shall be expressed in the ETA by means of a level according to clause 2.2.5.2 of EAD 210005-00-05.05.

b) Serviceability:

- Resistance to functional failure from soft body impact load – 50 kg

The resistance to functional failure from soft body impact load shall be expressed in the ETA by means of a level according to clause 2.2.5.1 of EAD 210005-00-05.05.

- Resistance to functional failure from hard body impact load – 0,5 kg

The resistance to functional failure from hard body impact load shall be expressed in the ETA by means of a level according to clause 2.2.5.2 of EAD 210005-00-05.05.

2.2.23 Thermal resistance / conductivity

Purpose of the assessment

The assessment is required to provide the thermal resistance and conductivity of the kit.

Assessment method

The thermal resistance / conductivity of the kit shall be determined on the basis of the thermal performances of its components.

This characteristic will be determined according to clause A.10 of annex A of EN 14509. The influence of the joint between panels is considered in this clause.

Expression of results

The thermal resistance / conductivity of the kit shall be expressed in the ETA by means of a level.

2.2.24 Air permeability

Purpose of the assessment

The assessment is required to provide the air permeability of the kit.

Assessment method

The air permeability of the kit shall be determined according to clause 5.2.7 of EN 14509 on a specimen made of all the components of the envelope which are part of the kit. The testing procedure of clause A.12 of Annex A of EN 14509 will be used.

The air permeability is only relevant for panels of external walls and roofs.

Expression of results

The air permeability of the kit shall be expressed in the ETA by means of a level.

3 ASSESSMENT AND VERIFICATION OF CONSTANCY OF PERFORMANCE

3.1 System(s) of assessment and verification of constancy of performance to be applied

For the products covered by this EAD the applicable European legal act is: Decision 2003/728/EC.

The system is: 1

In addition, with regard to reaction to fire for products covered by this EAD the applicable European legal acts are: Decision 98/436/EC amended by Decision 2001/596/EC, and Decision 98/437/EC amended by Decision 2001/596/EC.

The systems are: 1 or 3 or 4, depending on the conditions defined in these Decisions.

3.2 Tasks of the manufacturer

The cornerstones of the actions to be undertaken by the manufacturer of the product in the procedure of assessment and verification of constancy of performance are laid down in Table 3.2.1.

The manufacturer (regarding the components he buys from the market with DoP) shall take into account the Declaration of Performance issued by the manufacturer of that component. No retesting is necessary.

Table 3.2.1: Control plan for the manufacturer; cornerstones.

No	Subject/type of control	Test or control method	Criteria, if any	Minimum number of samples	Minimum frequency of control
Factory production control (FPC) [including testing of samples taken at the factory in accordance with a prescribed test plan]					
1	Density of the core material	3.4.1	Manufacturer's Control Plan	3	1 per shift / 6 h or 8 h ^(a)
2	Tensile strength and tensile modulus perpendicular to the faces of the panel	2.2.5	Manufacturer's Control Plan	3	1 per shift / 6 h or 8 h ^(a)
3	Compression strength at 10 % of deformation of the core	2.2.3	Manufacturer's Control Plan	3	1 per week ^(a)
4	Shear strength and shear modulus of the panel	2.2.1	Manufacturer's Control Plan	3	1 per week ^(a)
5	Tensile strength and thickness of the face material	3.4.2	Manufacturer's Control Plan	Testing is not necessary	Every batch
6	Bending moment and wrinkling stress in span and at central support of the panel	2.2.7	Manufacturer's Control Plan	1	1 per week ^(a)
7	Dimensions of the panel	3.4.3	Manufacturer's Control Plan	1	1 per shift / 6 h or 8 h
8	Thermal conductivity of the core material	3.4.4	Manufacturer's Control Plan	1	1 per month
9	Dimensions of the panel lock system	Measurement	Manufacturer's Control Plan	3	Every batch

No	Subject/type of control	Test or control method	Criteria, if any	Minimum number of samples	Minimum frequency of control
10	Materials of the panel lock system	3.4.5	Manufacturer's Control Plan	Testing is not necessary	Every batch
11	Tensile strength of the panel lock system	2.2.13	Manufacturer's Control Plan	1	1 per 3 months
12	Reaction to fire: density	3.4.1	Manufacturer's Control Plan	3	1 per shift / 6 h or 8 h
13	Reaction to fire: addition of fire retardants and/or limit of organic material	Supplier's declaration	Manufacturer's Control Plan	Testing is not necessary	Every delivery
Notes: ^(a) If the production is less than 2.000 m ² per manufacturing shift, then the property can be tested every 2.000 m ² or at least every 3 months.					

3.3 Tasks of the notified body

The cornerstones of the actions to be undertaken by the notified body in the procedure of assessment and verification of constancy of performance for the structural panelled building kit are laid down in Table 3.3.1.

Table 3.3.1: Control plan for the notified body; cornerstones.

No	Subject/type of control	Test or control method	Criteria, if any	Minimum number of samples	Minimum frequency of control
Initial inspection of the manufacturing plant and of factory production control					
1	<p>The notified product certification body shall verify the ability of the manufacturer for a continuous and orderly manufacturing of the product according to the manufacturer's Control Plan. In particular, the following items shall be appropriately considered:</p> <ul style="list-style-type: none"> • personnel and equipment • the suitability of the factory production control established by the manufacturer, especially those referred to: <ul style="list-style-type: none"> ○ Certificates of raw materials ○ Fire retardants applied and/or limit of organic material ○ Controls involved in the foaming process (density and foam injector's parameters) ○ Controls over finished products verified by testing. • full implementation of the prescribed test plan 	As defined in the control plan	As defined in the control plan	As defined in the control plan	--
Continuous surveillance, assessment and evaluation of factory production control					
2	<p>The notified product certification body shall verify that:</p> <ul style="list-style-type: none"> • the manufacturing process • the system of factory production control • the implementation of the prescribed test plan <p>are maintained</p>	As defined in the control plan	As defined in the control plan	As defined in the control plan	Once a year

3.4 Special methods of control and testing used for the verification of constancy of performance

3.4.1 Density of the core material

The density of the core material shall be determined according to clause A.8 of Annex A of EN 14509.

3.4.2 Tensile strength and thickness of the face material

The tensile strength and thickness of the face material shall be obtained from its certificate, in accordance with EN 10204.

3.4.3 Dimensions of the panel

The dimensions of the panel shall be determined in accordance with the relevant verification method of Annex D of EN 14509 for the following characteristics:

- Thickness of the panel (D.2.1)
- Flatness of the panel (D.2.2)
- Depth of the profile (D.2.3)
- Depth of stiffeners (D.2.4)
- Length of the panel (D.2.5)
- Width of the panel (D.2.6)
- Squareness (D.2.7)
- Straightness (D.2.8)
- Curvature (D.2.9)
- Pitch (D.2.10)
- Crest and valley width (D.2.11)

3.4.4 Thermal conductivity of the core material

The thermal conductivity of the core material shall be determined in accordance with clause A.10.2.1.1 of EN 14509, following the procedures described in the corresponding product standard of the core material.

3.4.5 Materials of the panel lock system

The materials of the panel lock system shall be determined from the documentation of the panel lock system.

4 REFERENCE DOCUMENTS

EN 10346:2015	Continuously hot-dip coated steel flat products for cold forming - Technical delivery conditions
EN 14509:2013	Self-supporting double skin metal faced insulating panels - Factory made products - Specifications
EN 826:2013	Thermal insulating products for building applications - Determination of compression behaviour
EN 1607:2013	Thermal insulating products for building applications - Determination of tensile strength perpendicular to faces
EN ISO 10456:2007 + AC:2009	Building materials and products - Hygrothermal properties – Tabulated design values and procedures for determining declared and design thermal values
EAD 210005-00-0505 of March 2019	Internal Partition Kits For Use as Non-loadbearing Walls.
EN 10204:2004	Metallic products - Types of inspection documents
EN 13501-1:2007	Fire classification of construction products and building elements - Part 1: Classification using data from reaction to fire tests
ISO 12941:1997	Statistical methods for quality control of building materials and components

ANNEX A – TEST METHODS

A.1 Compression strength and compression strength combined with lateral force of the panel

A.1.1 Compression strength of the panel

A.1.1.1. Principle

The test method given below simulates the behaviour of composite panels under various axial loads (e.g. ceiling panels being supported by wall panels).

In the test, a wall panel is placed vertically and compressed to determine the deformation and lateral deflection, and thus the axial load-bearing capacity of the panel.

A.1.1.2. Test apparatus

The apparatus shall be assembled in accordance with the detailed specifications as set out below, or equivalent.

A deflection transmitter, fixed to the face of the panel, in the middle of the panel. A compression transmitter shall be attached to the top of the panel.

A metal casing on top of the panel which covers the whole width and thickness of the panel shall be used to prevent the application of the load on only the composite panel core or facing.

A U-profile of suitable dimensions can be an option. The weight of this profile should be taken into account when calculating the applied load.

A.1.1.3. Number of tests

3 specimens of minimum thickness, 3 specimens of the intermediate thickness and 3 specimens of the maximum thickness must be tested.

The longest panel for each thickness defined by the manufacturer should be tested.

A.1.1.4. Conditioning and test conditions

Conditioning period is not necessary.

The tests shall be conducted in laboratory conditions, at a temperature of $(23 \pm 5) ^\circ \text{C}$.

A.1.1.5. Test assembly

The connection of the panel to the ground will be carried out by using the specific U-profile channel and anchoring the panel to it, which corresponds as much as possible with the end-use conditions.

The U-profile is fixed with screws to the ground.

A uniformly distributed load shall be applied in the axis of the panel (figure A.1.1.5.1).

Note: if necessary because of the length of the panel to be tested, it is possible to rotate the panel in order to apply the load horizontally (see the figure below). If this is the case, the connection to the ground may be reformulated.

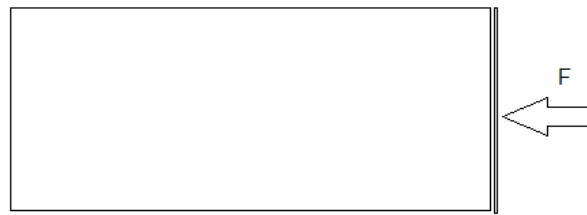

Figure A.1.1.5.1: Application of load horizontally on the panel.

A.1.1.6. Test procedure

The panels shall be tested as a column, having a flat end at the bottom. Compressive loads shall be applied to a steel plate covering the upper end of the assembly. Apply the load uniformly on the area of the transverse section.

The rate of loading ($0,8 \pm 0,1$) mm/min has been found satisfactory.

The load shall be applied until the failure of the panel.

Attach four compression meters to the faces of the specimen, one near each corner of the specimen, to measure the shortening of the assembly. Record the readings to the nearest 0,025 mm.

Attach two deflection meters, one to each edge of the assembly. Record the readings continuously, to the nearest 0,25 mm.

A.1.1.7. Expression of test results

A.1.1.7.1. Deformation

For each compression meter, calculate the shortening under each load as the difference between the reading of the compression meter when the load is applied and the initial reading. Calculate the shortening of the panel as the average of the shortenings for each of the four compression meters, multiplied by the ratio: specimen length divided by the compression meter gauge length.

Obtain the sets in a similar manner.

A.1.1.7.2. Lateral deflection

Calculate the lateral deflection and the lateral set under each load for each deflection meter as the difference between the reading of the deflection meter when the load is applied and the initial reading. Calculate the lateral deflection and lateral set for the panel as the average of the lateral deflection and lateral set of the two deflection meters.

A.1.1.7.3. General

Record the maximum load for each specimen and report the results of load-deformation and load- deflection measurements in the form of a graph.

Report gauge lengths of all deflection or deformation gauges.

For extended application of the test results, the general rule is that test results for the worst case assembly can be used to reflect the behaviour of other ones.

A.1.1.8. Test report

The test report shall include the following information:

- reference to this EAD, Annex A.1.1
- the name of the testing laboratory
- the name of the ETA-Applicant (and manufacturer of the panel)
- date of the test
- description of the test instruments
- identification of the product tested (designation, dimensions and any relevant identification characteristic)
- identification of the sample(-s) tested (dimensions, shape, etc.) and reference to its marking (if any)
- surface structure (e.g. smooth, profiled, structured, ...)
- description of conditioning and preparation of the sample (if any)
- the speed of applying the load
- description of test conditions (temperature and RH)
- results of the test (deflection and corresponding loads), including a description of damages during the test and the reason for terminating the test.

A.1.2 Compression strength combined with lateral force of the panel

The compression strength alone will be provided from the test results of annex A.1.1.

The bending strength obtained from clause 2.2.7 will be used as the lateral force to be combined with the compression force.

The goal of this test procedure is to draw a graph of lateral force vs. compression strength of the panel. The points of the graph are shown in the figure below.

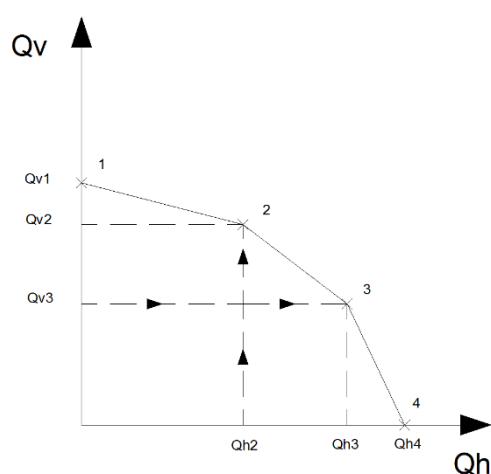

- Qv: Compression load (kN)
- Qh: Lateral load (kN). Equivalent to bending load.
- Qv1: Compression load obtained from the compression strength test of the panel. Lateral load = 0.
- Qv2: Compression load obtained from the tests with $Qh2 = 0,5 \cdot Qh4$
- Qv3: Compression load equal to $0,5 \cdot Qv1$.
- Qh4: Lateral load obtained from the bending tests of the panel. Compression load = 0.
- Qh3: Lateral load obtained from the tests with $Qv3 = 0,5 \cdot Qv1$.
- Qh2: Lateral load equal to $0,5 \cdot Qh4$.

Figure A.1.2.1: Graphic compression strength vs. lateral force.

A.1.2.1. Test method

The test method of annex A.1.1 with the following amendments will be used:

A compression load and a lateral load (bending load) will be applied simultaneously on the samples. Two types of tests shall be carried out:

- Type 1: Test with a constant compression load ($0,5 \cdot Q_{v1}$) in which the lateral load (bending load) is increased progressively, up to the failure of the panel.
- Type 2: Test with a constant lateral load (bending load) ($0,5 \cdot Q_{h4}$) in which the compression load is increased progressively, up to the failure of the panel.

A.1.2.2. Principle

The test method simulates the behaviour of the panel under compression and lateral load applied simultaneously (e.g. external walls submitted to vertical loads and wind actions).

A.1.2.3. Test apparatus

The indications of clause A.1.1 are valid for the application of the compression load. The indications of clause A.5.2 of Annex A of EN 14509 are valid for the application of the lateral load (bending load).

The application of the compression load and the lateral load must be simultaneous.

A.1.2.4. Number of tests

The panel with structural uses must be tested.

3 specimens of minimum thickness, 3 specimens of the intermediate thickness and 3 specimens of the maximum thickness must be tested.

The longest panel for each thickness defined by the manufacturer should be tested.

A set of tests will be conducted for type 1 tests and another set of tests will be conducted for type 2 tests.

A.1.2.5. Conditioning and test conditions

Conditioning period is not necessary.

The tests shall be conducted in laboratory conditions, at a temperature of $(23 \pm 5) ^\circ \text{C}$.

A.1.2.6. Test assembly

The connection of the panel to the ground will be carried out by using the specific U-profile channel and anchoring the panel to it, which corresponds as much as possible with the end-use conditions.

The U-profile is fixed with screws to the ground.

Note: if necessary because of the length of the panel to be tested, it is allowed to rotate the panel in order to apply the compression load horizontally and the bending load vertically (see the figure below). If this is the case, the connection to the ground may be reformulated.

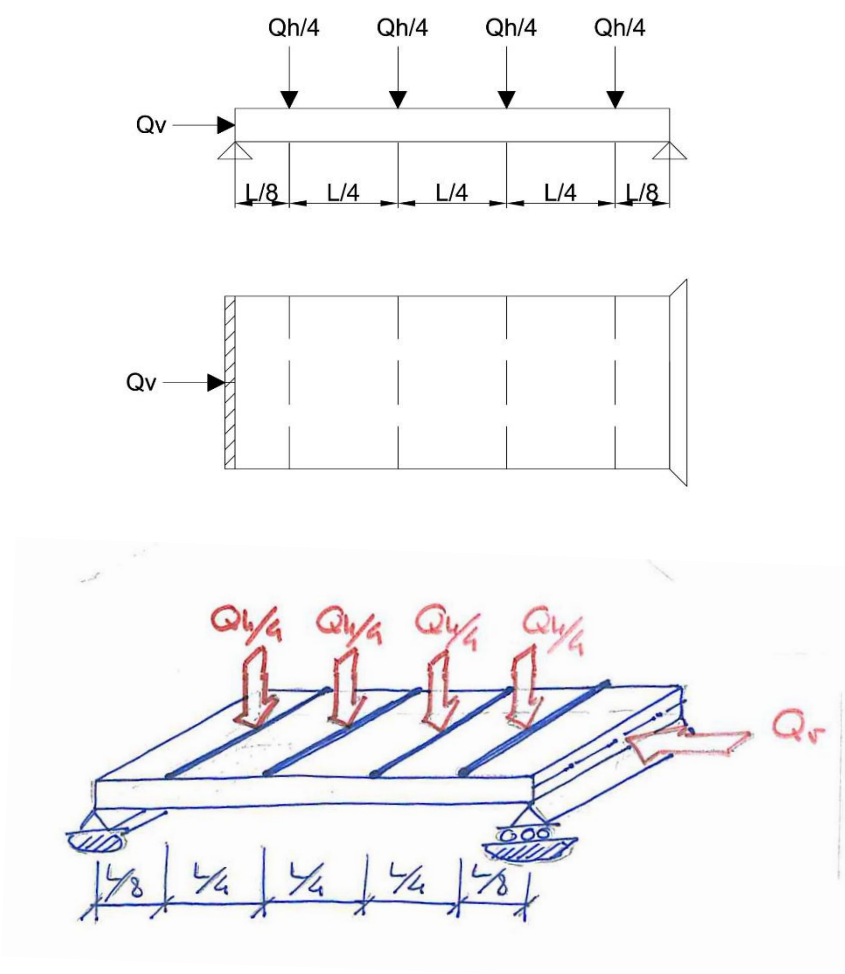

Figure A.1.2.6.1: Test assembly.

A.1.2.7. Test procedure

The application of the compression load (uniformly along a line parallel to the inside face, and one-third the thickness of the assembly from the inside face) is valid. The lateral load (bending load) shall be applied according to figure A.8 of annex A of EN 14509.

The rate of loading ($0,8 \pm 0,1$) mm/min for compression or lateral load is valid. The indications for rate of loading of clause A.5 of EN 14509 apply for lateral load.

The load shall be applied until the failure of the panel, whereas it was the type of failure (by compression or lateral load).

A.1.2.8. Expression of test results

The content of clause A.1.1.7 of this EAD is applicable for compression load. The content of clause A.5 of EN 14509 apply for lateral load.

The mean value and the 5 %-fractile value with a confidence level of 75 % using a log-normal distribution shall be considered the test results. The 5 %-fractile will be used in the elaboration of graphs.

Additionally, a graph must be drawn from the test results (see figure A.1.2.1). The graph shall be obtained from joining the points of failure with a straight line.

A.2 Crushing strength of the wall to floor joint of the panel

A.2.1 Test method

A compression load will be applied on a wall to floor joint in order to determine the crushing strength of this joint. The load will be applied on the wall panel.

The failure can occur in the wall panel, in the lock system or in the floor panel.

A.2.2 Principle

The test method simulates the behaviour of the wall to floor joint when a compression load is applied.

A.2.3 Test apparatus

The test apparatus and the conditions used in the compression strength of the panel test (clause A.1.1.2) are valid for this test.

A.2.4 Number of tests

The panel with structural uses must be tested.

3 specimens of minimum thickness, 3 specimens of the intermediate thickness and 3 specimens of the maximum thickness must be tested.

A.2.5 Conditioning and test conditions

Conditioning period is not necessary.

The tests shall be conducted in laboratory conditions, at a temperature of $(23 \pm 5) ^\circ \text{C}$.

A.2.6 Test assembly

The wall and floor panels will be joined by the locking system.

The compression load shall be applied on the wall panel as part of the test assembly described in the figure A.2.6.1 which is 500 mm long. This compression load shall be applied progressively up to the failure load identified in the compression load test.

A U-profile shall be used for applying the load on the wall panel. The load will be applied on the axis of the panel.

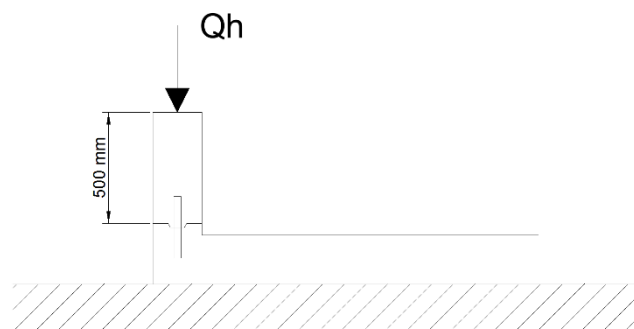

Figure A.2.6.1: Test assembly.

A.2.7 Test procedure

The rate of loading ($1,0 \pm 0,1$) mm/min is valid. The load shall be applied until the failure of the wall panel, the failure of the floor panel or the failure of the lock system.

A.2.8 Expression of test results

If the failure occurs in the wall panel, then the compression strength of the wall (clause 2.2.8 of this EAD) is limiting. On the contrary, if the failure occurs in the floor panel or in the lock system then this value is the limiting, and the compression strength of the wall must be limited by this value.

The mean value and the 5 %-fractile value with a confidence level of 75 % using a log-normal distribution shall be considered the test results. The 5 %-fractile will be used in the elaboration of graphs.

A.3 Shear strength perpendicular to the panels' face of the panel lock system

A.3.1 Test method

A shear load will be applied on a specimen made up of equal parts of two adjacent panel sections to determine the shear strength perpendicular to the panels' face of the panel lock system.

A.3.2 Principle

The test method simulates the behaviour of the panel lock system when a shear load perpendicular to the panels' face is applied.

A.3.3 Test apparatus

The apparatus used in the test shall be able to restrain a panel section and to apply a shear load perpendicular to the panels' face on the other section simultaneously.

If necessary, a rigid flat shape steel profile capable of withstanding the load without any deformation can be used on the panel section during the load application, in order to assure a uniform distribution of this load on the test assembly (see figure A.3.5.1).

A.3.4 Number of tests

5 specimens shall be tested for each type of panel lock system.

The main dimensions and the properties of the materials of the tested lock systems shall be recorded.

A.3.5 Test assembly

The test assembly will consist of two equal parts of two adjacent panel sections, incorporating a lock and a receiver, which will be locked together. A gradually increasing shear load perpendicular to the panels' face will be applied. The necessary force to achieve separation or failure of the test assembly shall be measured and recorded.

The minimum dimensions of each panel section with lock system are (width x height): (300 ± 5) mm x (300 ± 5) mm. Any thickness of the panels is suitable.

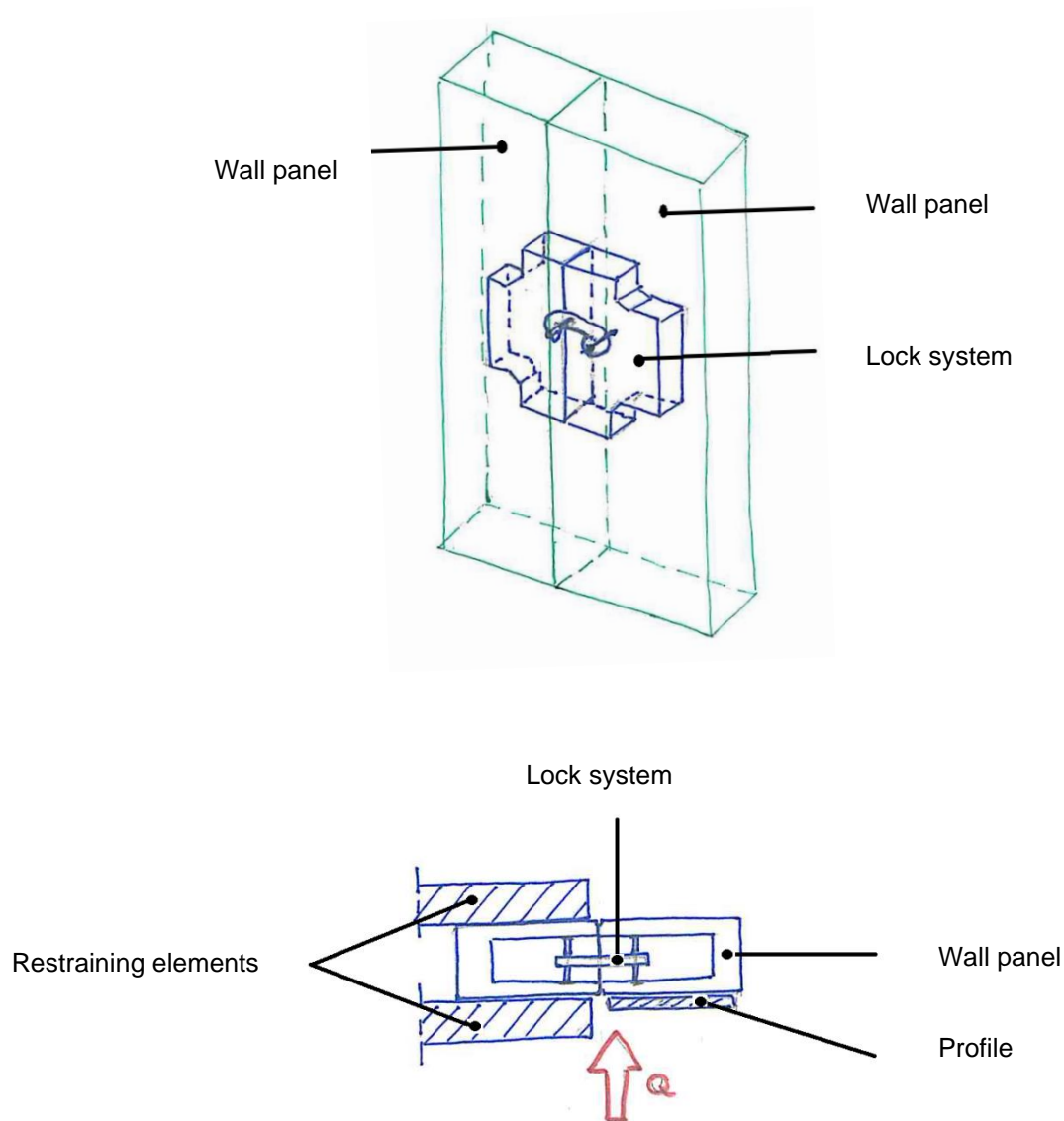

Figure A.3.5.1: Example of test assembly.

A.3.6 Test procedure

The rate of loading ($4,0 \pm 1,0$) mm/min is valid. The load shall be applied until the failure of the lock system or the failure of the panel section.

The shear load for which the lock system fails or for which the panel section is damaged is considered the ultimate load of the test.

A.3.7 Expression of test results

The failure mode (of the lock system or of the panel section) and the ultimate load achieved shall be reported.

The mean value and the 5 %-fractile value with a confidence level of 75 % using a log-normal distribution shall be considered the test results.

A.4 Shear strength parallel to the panels' face of the panel lock system

A.4.1 Test method

A shear load will be applied on a specimen made up of equal parts of two adjacent panel sections to determine the shear strength parallel to the panels' face of the panel lock system.

A.4.2 Principle

The test method simulates the behaviour of the panel lock system when a shear load parallel to the panels' face is applied.

A.4.3 Test apparatus

The apparatus used in the test shall be able to restrain a panel section and to apply a shear load parallel to the panels' face on the other section simultaneously.

A U-profile on the panel section can be used during the load application in order to assure a uniform distribution of this load on the test assembly.

A.4.4 Number of tests

5 specimens shall be tested for each type of panel lock system and for each hook arrangement (upwards and downwards).

The main dimensions and the properties of the materials of the tested lock systems shall be recorded.

A.4.5 Test assembly

The test assembly will consist of two equal parts of two adjacent panel sections, incorporating a lock and a receiver, which will be locked together. A gradually increasing shear load parallel to the panels' face will be applied. The necessary force to achieve separation or failure of the test assembly shall be measured and recorded.

The minimum dimensions of each panel section with lock system are (width x height): (300 ± 5) mm x (300 ± 5) mm. Any thickness of the panels is suitable.

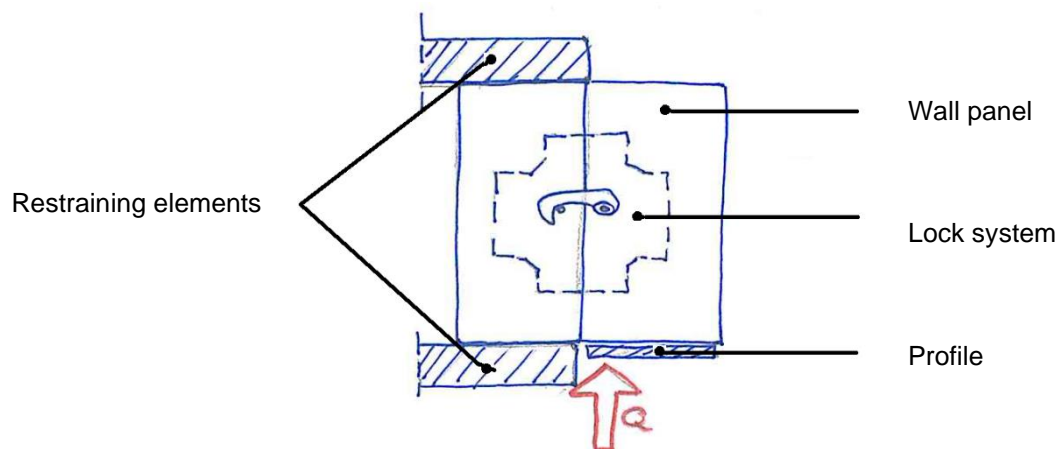

Figure A.4.5.1: Example of test assembly.

A.4.6 Test procedure

The rate of loading ($4,0 \pm 1,0$) mm/min is valid. The load shall be applied until the failure of the lock system or the failure of the panel section.

The shear load for which the lock system fails or for which the panel section is damaged is considered the ultimate load of the test.

A.4.7 Expression of test results

The failure mode (of the lock system or of the panel section) and the ultimate load achieved shall be reported.

The mean value and the 5 %-fractile value with a confidence level of 75 % using a log-normal distribution shall be considered the test results.

A.5 Tensile strength of the panel lock system

A.5.1 Test method

A tensile load will be applied on a specimen made up of equal parts of two adjacent panel sections to determine the tensile strength of the panel lock system.

A.5.2 Principle

The test method simulates the behaviour of the panel lock system when a tensile load is applied.

A.5.3 Test apparatus

The apparatus used in the test shall be able to restrain a panel section and to apply a tensile load on the other section simultaneously.

A.5.4 Number of tests

5 specimens shall be tested for each type of panel lock system.

The main dimensions and the properties of the materials of the tested lock systems shall be recorded.

A.5.5 Test assembly

The test assembly will consist of two equal parts of two adjacent panel sections, incorporation a lock and a receiver, which will be locked together and then pulled apart by applying a gradually increasing force. The necessary force to achieve separation shall be measured and recorded.

The dimensions of each panel section with lock system are (width x height): (300 ± 5) mm x (300 ± 5) mm.

The failure can occur in the panel section, in the joint between foam and lock system or in the lock system itself. The failure mode shall be recorded.

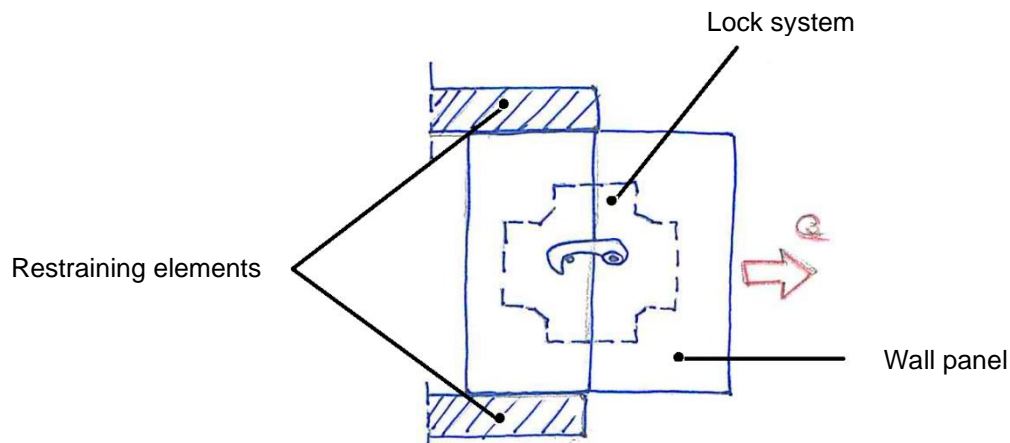

Figure A.5.5.1: Example of test assembly.

A.5.6 Test procedure

The rate of loading ($4,0 \pm 1,0$) mm/min is valid. The load shall be applied until the failure of the test assembly.

A.5.7 Expression of test results

The mean value and the 5 %-fractile value with a confidence level of 75 % using a log-normal distribution shall be considered the test results, as well as the failure mode obtained.

A.6 Shear strength of the panel lock system with profile

A.6.1 Test method

A shear load will be applied on a specimen made up of a lock embedded in a panel section, and a profile fixed to a panel to determine the shear strength of the panel lock system with profile.

A.6.2 Principle

The test method simulates the behaviour of the panel lock system with profile when a shear load along the profile is applied.

A.6.3 Test apparatus

The apparatus used in the test shall be able to restrain a panel section and to apply a shear load along the profile fixed to a panel simultaneously. If necessary, it is acceptable to restrain the profile fixed to a panel and to apply the shear load to the panel section.

A U-profile on the panel section can be used during the load application in order to assure a uniform distribution of this load on the test assembly.

A.6.4 Number of tests

5 specimens shall be tested for each type of panel lock system with profile.

The main dimensions and the properties of the materials of the tested lock systems shall be recorded.

A.6.5 Test assembly

The indications regarding the test assembly of clause A.7.5 are valid.

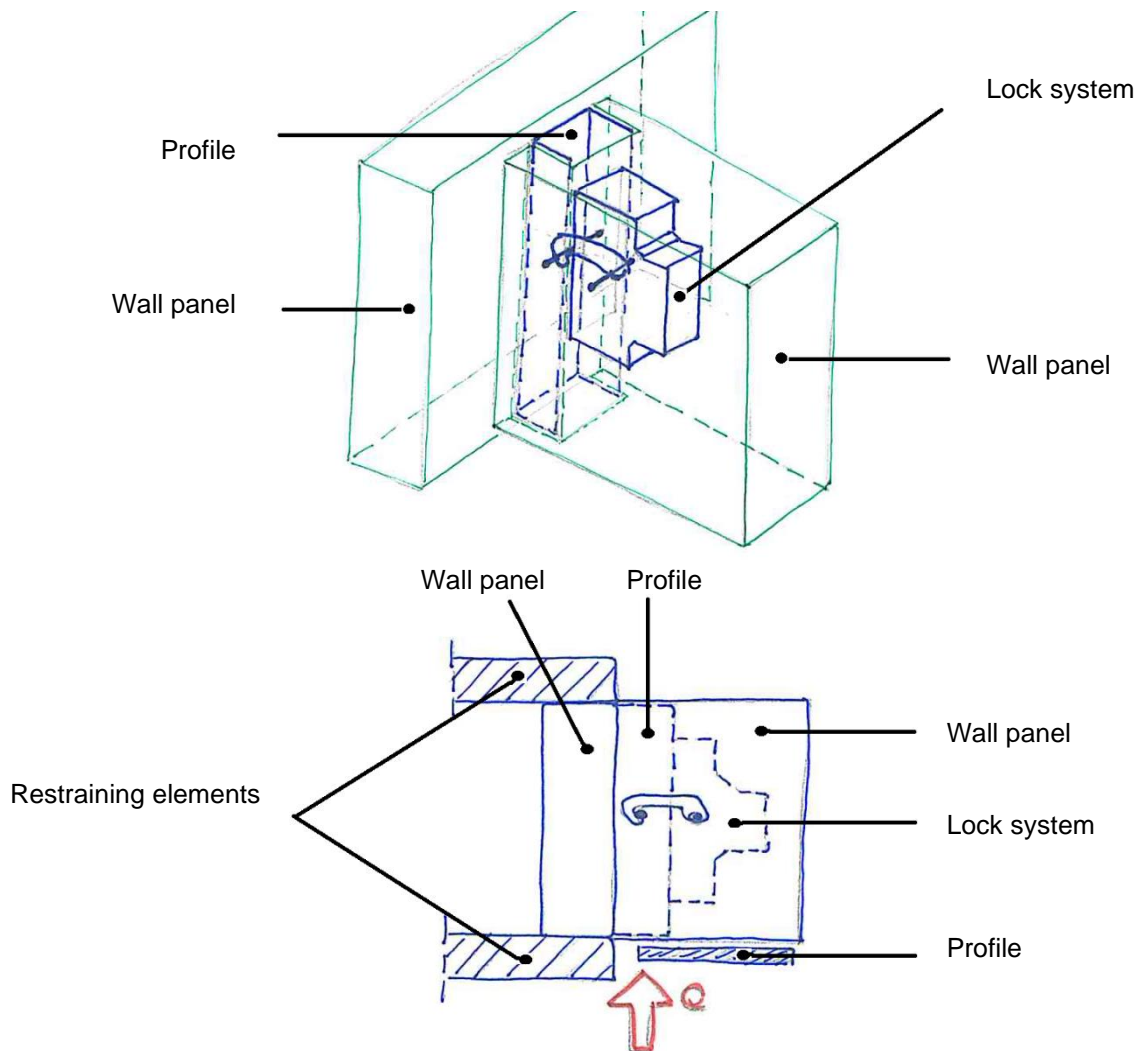

Figure A.6.5.1: Example of test assembly.

A.6.6 Test procedure

The rate of loading ($4,0 \pm 1,0$) mm/min is valid. The load shall be applied until the failure of the test assembly.

A.6.7 Expression of test results

The mean value and the 5 %-fractile value with a confidence level of 75 % using a log-normal distribution shall be considered the test results, as well as the failure mode obtained.

A.7 Tensile strength of the panel lock system with profile

A.7.1 Test method

A tensile load will be applied on a specimen made up of a lock embedded in a panel section, and a profile fixed to a panel to determine the tensile strength of the panel lock system with profile.

A.7.2 Principle

The test method simulates the behaviour of the panel lock system with profile when a tensile load is applied.

A.7.3 Test apparatus

The test apparatus shall fulfil the requirements of the test apparatus of clause A.5.3 of this EAD.

A.7.4 Number of tests

5 specimens shall be tested for each type of panel lock system with profile.

The main dimensions and the properties of the materials of the tested lock systems shall be recorded.

A.7.5 Test assembly

The test assembly will consist of a specimen made up of a lock embedded in a panel section, and a profile fixed to a panel. The receiver is in the profile. The lock and the receiver will be locked together and then pulled apart by applying a gradually increasing force. The necessary force to achieve separation shall be measured and recorded.

The dimensions of the panel section with a lock embedded are (width x height): (250 ± 5) mm x (250 ± 5) mm. The length of the profile is 250 mm and the profile is fixed to a supporting panel section of (width x height): (250 ± 5) mm x (250 ± 5) mm.

The failure can occur in the panel section, in the lock system itself, in the profile or in the supporting panel of the profile. The failure mode shall be recorded.

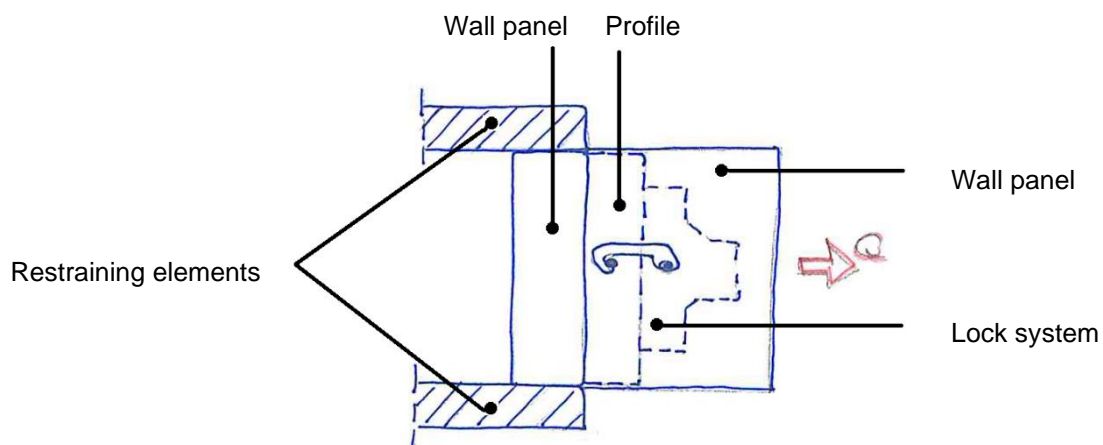

Figure A.7.5.1: Example of test assembly

A.7.6 Test procedure

The rate of loading ($4,0 \pm 1,0$) mm/min is valid. The load shall be applied until the failure of the test assembly.

A.7.7 Expression of test results

The mean value and the 5 %-fractile value with a confidence level of 75 % using a log-normal distribution shall be considered the test results, as well as the failure mode obtained.

A.8 Combined tensile and shear strength of all type of connections

The combined tensile and shear strength of all type of connections can be determined by means of the following calculation procedure, based on the tensile and shear strength of the connections determined individually.

$$\beta_N + \beta_V \leq 1,2$$

Where:

β_N, β_V : ratios between design action and design resistance for tensile and shear loading.

$$\beta_N = \frac{N_d}{N_{Rd}} \leq 1$$

$$\beta_V = \frac{V_d}{V_{Rd}} \leq 1$$

Where:

N_d and V_d : Design tensile and shear loading, respectively, obtained from the actions applied on the connections.

N_{Rd} and V_{Rd} : Design tensile and shear strength, respectively, obtained from the individual strength values.

The combinations between tensile and strengths are as follows (see also table A.8.1):

Design tensile strength of the panel lock system (clause A.5) shall be combined with design shear strength perpendicular (clause A.3) or parallel (clause A.4) to the panel's face of the lock system, depending on the design requirements.

Design tensile strength of the panel lock system with profile (clause A.7) shall be combined with the design shear strength of the panel lock system with profile (clause A.6).

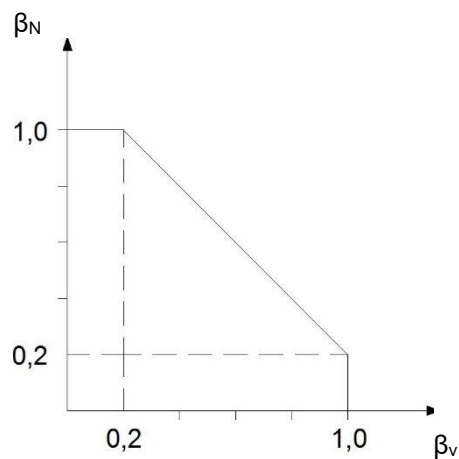

Figure A.8.1: Interaction diagram for combined tensile and shear loads.

This approach yields, in general, to conservative results. If more precise results are sought, then the following test procedure must be applied.

A.8.1 Test method

The goal of this test procedure is to draw a graph of tensile strength vs. shear strength of the connection. The points of the graph are shown in the figure below, in which the characteristic tensile ($N_{R,k}$) will be obtained from the test results of the clause A.5 or A.7 in accordance with the type of connection, and the characteristic shear strength ($V_{R,k}$) will be obtained from the test results of A.3, A.4 or A.6, in accordance with the type of connection and the direction of the effort.

The tensile and shear strengths (N_2 and V_3) shall be obtained from the following tests, in which a tensile and a shear load are applied:

- Type 1: Test with a constant tensile load ($0,5 \cdot N_{R,k}$) in which the shear load is increased progressively, up to the failure of the lock system or the failure of the panel.
- Type 2: Test with a constant shear load ($0,5 \cdot V_{R,k}$) in which the tensile load is increased progressively, up to the failure of the lock system or the failure of the panel.

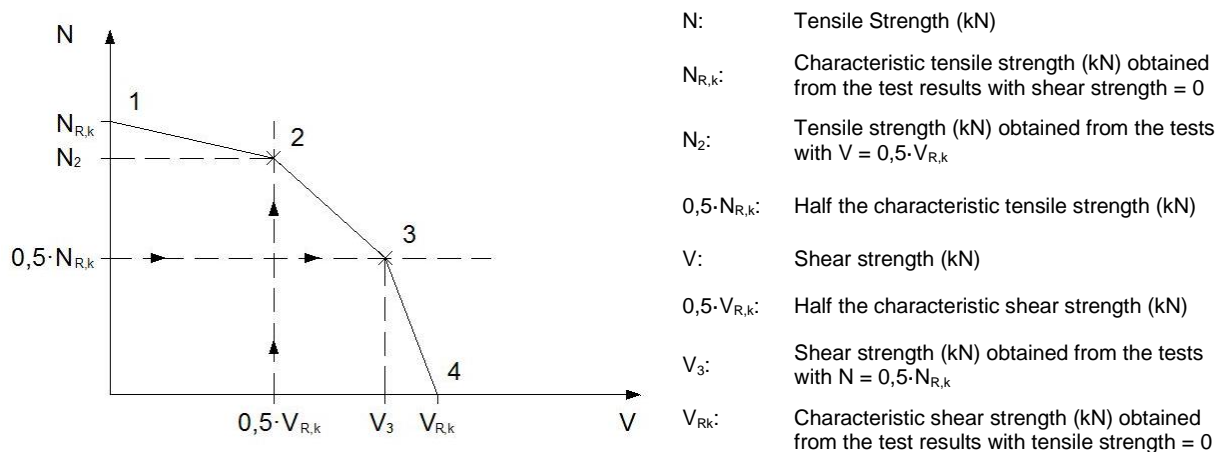

Figure A.8.1.2: Graphic tensile vs. shear strength of connections.

A.8.2 Principle

The test method simulates the behaviour of the connections under tensile and shear load applied simultaneously.

A.8.3 Test apparatus

The indications of the clause A.5.3 will be combined with the indications of clause A.3.3 for tensile and shear strength perpendicular to the panels' face of the panel lock system, or with the indications of clause A.4.3 for the shear strength parallel to the panels' face of the panel lock system.

The indications of clause A.6.3 will be combined with the indications of clause A.7.3 for the panel lock system with profile.

The application of the compression load and the lateral load must be simultaneous.

The combinations indicated above are described in the following table:

Combination	Tensile strength	Shear strength
1	of the panel lock system [clause A.5.3]	perpendicular to the panels' face of the lock system [clause A.3.3]
2		parallel to the panels' face of the panel lock system [clause A.4.3]
3	of the panel lock system with profile [clause A.7.3]	of the panel lock system with profile [clause A.6.3]

Table A.8.3.1: Combinations of tensile and shear strength.

A.8.4 Number of tests

5 specimens shall be tested for each type of panel lock system.

The main dimensions and the properties of the materials of the tested lock systems shall be recorded.

A.8.5 Conditioning and test conditions

Conditioning period is not necessary.

The tests shall be conducted in laboratory conditions, at a temperature of $(23 \pm 5) ^\circ \text{C}$.

A.8.6 Test assembly

The dimensions of the test assembly will correspond with the dimensions specified in the testing procedure for each type of connection, panel lock system between panels or panel lock system with profile.

A.8.7 Test procedure

The application of the two loads in each type of test will not be simultaneous. Each test will start with the application of the load which leads to $0,5 \cdot N_{Rk}$ or $0,5 \cdot V_{Rk}$. This first load will be applied with the loading rate corresponding to the individual characteristic (see clauses A.5.6 or A.7.6 for tensile, and A.3.6, A.4.6 or A.6.6 for shear). When the loading $0,5 \cdot N_{Rk}$ or $0,5 \cdot V_{Rk}$ is reached, it shall be kept constant during 5 minutes at most, then the second load will be applied with the loading rate corresponding to the individual characteristic until the failure of the test assembly.

Settlements during the application of the first load are not expected because of the load level achieved ($0,5 \cdot N_{Rk}$ or $0,5 \cdot V_{Rk}$). If they appear and can have influence in the application of the second load, the point of application of the second load will be adjusted.

A.8.8 Expression of test results

The mean value and the 5 %-fractile value with a confidence level of 75 % using a log-normal distribution shall be considered the test results. The 5 %-fractile will be used in the elaboration of graphs.

The graph must be drawn from the test results (see Figure A.8.1.2). A graph shall be obtained from joining with a straight line the points of failure.

A.9 Racking resistance of wall panel assemblies

A.9.1 Test method

The objective of these tests is to determine the racking resistance provided by panels or vertical wall elements. This test specification follows the principles of EN 594, but has been adapted to cover a range of products and assemblies.

The racking resistance test simulates the behaviour of a composite panel or wall assembly, resulting from a load being exercised in the plane of the panel (e.g. wind loads in walls or floors acting as diaphragms).

A.9.2 Principle

The test method measures the resistance to racking load of panels or vertical wall elements, which can deform both vertically and horizontally in the plane of the panel.

In this test method, the panel is fastened to the substrate in accordance with manufacturer's specifications, ensuring that the test result corresponds with behaviour in normal use.

A.9.3 References

This test method is derived from the following reference document:

EN 594:2011 Timber structures - Test methods - Racking strength and stiffness of timber frame wall panels

A.9.4 Definitions

Racking strength: capacity of a panel to resist a horizontal load in the plane of the panel.

Racking stiffness: calculated stiffness of a panel when it is loaded to approximately 40% of its racking strength.

A.9.5 Symbols

- F: applied racking load, in N;
- F_{max}: maximum racking load, in N;
- F_{max,est}: estimated maximum racking load, in N;
- F_v: applied vertical load, in N;
- R: racking stiffness, in N/mm;
- v: panel deformation, in mm.

A.9.6 Test specimen

The configurations, amongst the following, for which the manufacturer claims for racking resistance shall be tested:

- a) An external wall panel assembly with the maximum opening size.
- b) An external wall panel assembly without openings.
- c) An internal wall panel assembly.

The assembly will consist of three interlocked panels for configuration a) and two interlocked panels for configurations b) and c).

The panels with the highest ratio height over width in its minimum thickness, for which the manufacturer claims for racking resistance shall be tested.

A.9.7 Number of tests

One assembly of each configuration for which the manufacturer claims for racking resistance shall be tested.

A.9.8 Preparation of specimens

The sample conditioning shall be recorded. The conditioning period shall be agreed between the ETA-applicant and the TAB.

The test shall be carried out in laboratory circumstances.

A.9.9 Test apparatus

A.9.9.1. Loading apparatus

The test apparatus shall be in accordance with the schematic presentation in Figure A.9.9.2.1 and with the detailed specifications as set out below, or equivalent.

It shall be capable of applying, separately, both racking load F , and vertical loads F_v . The method of application of the loads shall be such that no significant resistance to movement in the panel is induced.

The apparatus shall be capable of continuously recording the loads F and F_v with an accuracy of $\pm 3\%$ of the load applied, or, for loads of less than $0,1 \times F_{\max,est}$ with an accuracy of $\pm 0,3\% F_{\max,est}$. The panel displacements shall be measured to the nearest $0,1\text{ mm}$.

If necessary, a metal casing shall be used to prevent the load being applied on only the composite panel core or facing or on parts of a designed panel joint, causing unrepresentative local deformations.

A.9.9.2. Deflection transmitter

Three deflection transmitters (A, B and C of figure A.9.9.2.1) are fixed to the side of the panel assembly.

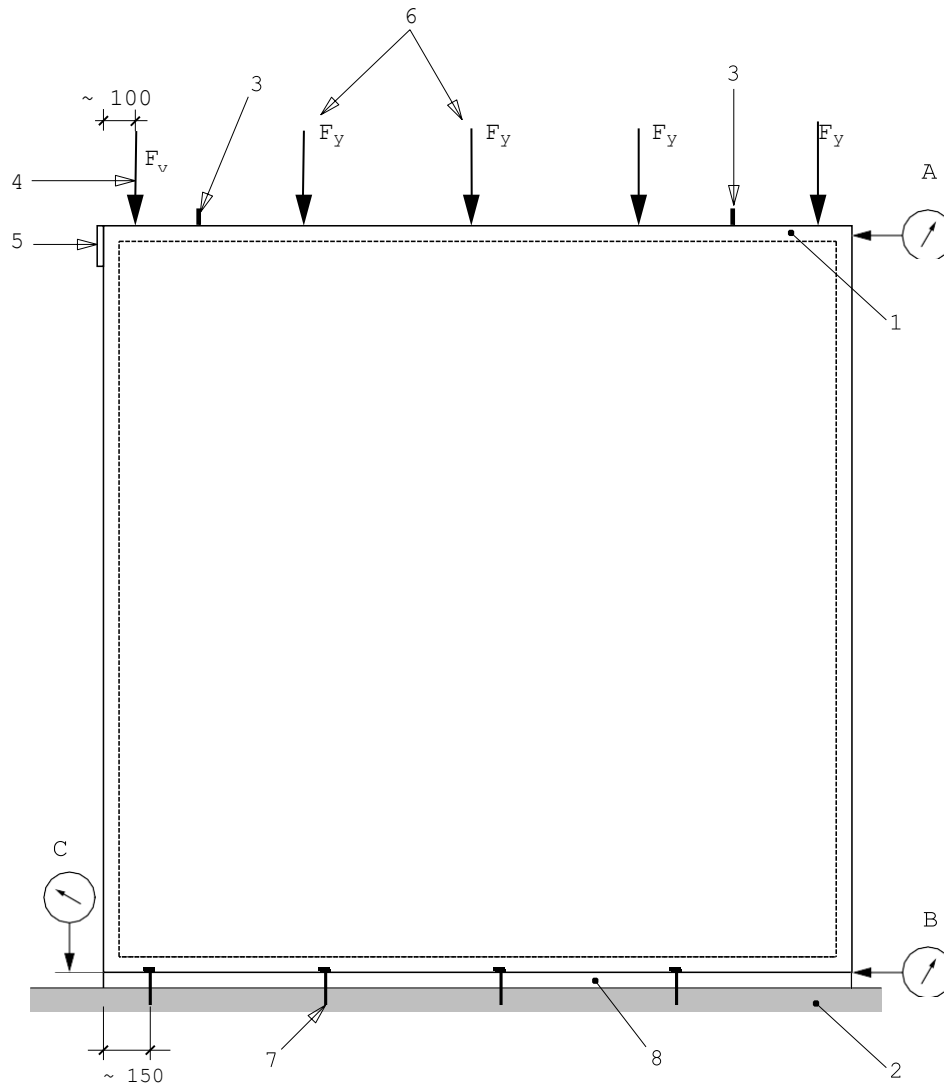

Figure A.9.9.2.1: Test apparatus

Key

- 1 Head binder.
 - 2 Base of test rig.
 - 3 Lateral restraints arranged so as not impeding the movement of panel within its plane.
 - 4 Leading loading point set back if using fixed loading position allowing 100 mm maximum racking deflection.
 - 5 Racking load (F) applied at top of panel or to metal plate attached to top rail of panel and head binder.
 - 6 Vertical load spread equally to each stud (or equivalently distributed) and applied so as not to impede racking reflection on panel.
 - 7 Fastening system in accordance with manufacturer's specifications.
 - 8 Timber packer of similar section as the panel.
- A, B, C: Points of displacement measurement.

A.9.10 Test assembly**A.9.10.1. Panel assembly or wall element**

The panel assembly consists of 2 panels and shall be mounted in accordance with the ETA-applicant's installation specifications, with regard to the intended use, so that the test assembly corresponds as much as possible with the end- use conditions.

The way in which components are fixed to each other and to the floor shall be in accordance with the ETA-applicant's specifications and reproduce actual conditions of use, particularly with respect to the nature, type and position of the fixings and the distance between them.

A.9.10.2. Base and loading frame

The base of the test assembly shall provide a level bed to receive the test panel. The base shall be sufficiently stiff so as not to distort during the test. A rigid datum (independent of the test rig) shall be provided for the measurement of the deformation of the panel.

A.9.10.3. Mounting of test panel

The head binder shall be rigidly attached to the top of the panel. The cross-sectional dimensions and position shall provide a firm interface between the loads and the panel and allow the free movement of the panel sheathing of faces during the test. Lateral restraints shall be provided through the head binder so that the head or top of the panel will deflect only in the plane of the panel.

A.9.11 Test procedure

A.9.11.1. General

The vertical loads F_v shall be applied at locations appropriate to the design of the panel normally uniformly distributed. The method of application of the vertical loads shall allow for racking deflections up to 100 mm.

The first point of application of vertical load shall be positioned approximately 100 mm from the end of the panel (see Figure A.9.9.2.1). The racking load F shall be applied as shown in Figure A.9.9.2.1. The load shall be applied at a constant rate of movement related to the displacement at gauge A.

For loading up to F_{max} the rate of loading shall be such that 90% of F_{max} is achieved in (300 ± 120) s. The displacements of the panel shall be monitored at points A, B and C (see Figure A.9.9.2.1). The deformation v shall be taken as the displacement at A minus the displacement at B. The displacement at C shall be reported separately.

A.9.11.2. Vertical preload

A vertical preload cycle is required. The procedure is carried out by applying vertical preloads of $1 \text{ kN} \pm 10\%$.

These loads shall be maintained for (120 ± 10) s, then released and the panel allowed to recover for a minimum of (300 ± 10) s before continuing the test.

A.9.11.3. Stabilizing load cycle

The vertical loads F_v shall be applied to the head binder, as shown in Figure A.9.9.2.1 and maintained constant throughout the cycle. The racking load F shall then be applied and increased to $0,1 \times F_{max,est}$ and maintained for (120 ± 10) s. It shall then be removed and the panel allowed a recovery period of (600 ± 300) s, before continuing the test.

A.9.11.4. Strength test

Maintain the vertical loads F_v applied in the stabilizing load cycle. The racking load F shall then be increased until F_{max} is reached. The racking load shall be applied at the rate specified above (see A.9.11.1).

Note 1. The rate of loading should ensure that 90 % of the racking load F_{max} is reached within (300 ± 120) s. It is advised that the mean time to this load is about 300 s.

Note 2. F_{max} is reached when either:

- the panel collapses, or
- the panel attains a deformation v (see A.9.11.1) of 100 mm, whichever occurs first.

The deformations v_2 and v_4 and the corresponding racking loads shall be recorded (see Figure A.9.11.4.1).

Note 3 It is important to ensure that the panel has totally failed when the racking load begins to reduce; it is common for panels to recover the load lost when individual fixings fail by redistributing the load to the remaining fixings.

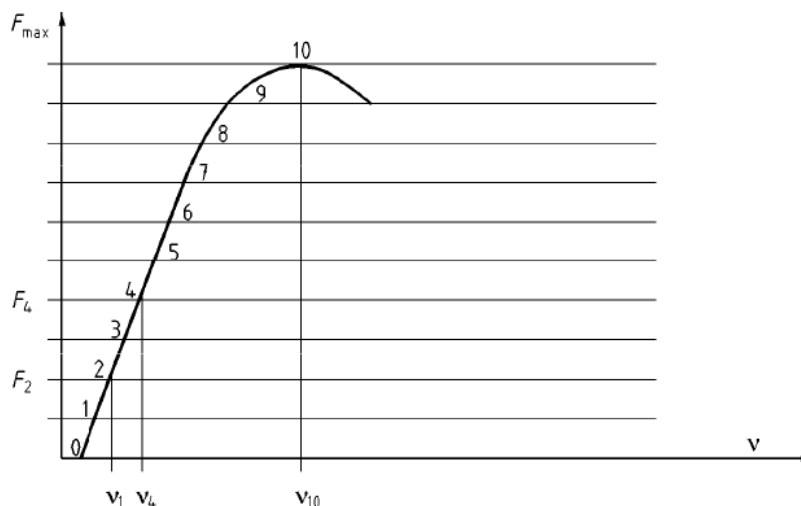

Figure A.9.11.4.1: Typical racking load versus deflection curve

A.9.12 Expression of results

The test results shall contain:

- a) racking stiffness of the panel, calculated from the equation

$$R = (F_4 - F_2) / (v_4 - v_2)$$

Where:

F_2 is the racking load of $0,2 \times F_{max}$, in N

F_4 is the racking load of $0,4 \times F_{max}$, in N

v_2 is the deformation, in mm as determined in the stiffness test;

v_4 is the deformation, in mm as determined in the stiffness test;

- b) racking strength, expressed as the value of the maximum racking load F_{max} as found in the strength test;
- c) vertical loads F_v and the total vertical load.
- d) a record of the displacement at C (see Figure A.9.9.2.1).

A.9.13 Test report

The test report shall include at least the following information:

- a) reference to this EOTA EAD, Annex A.9
- b) the name of the testing laboratory

- c) the name of the ETA-Applicant (and manufacturer of the composite panel)
- d) date of the test
- e) description of the test instruments
- f) identification of the product tested (designation, dimensions and any relevant identification characteristic)
- g) identification of the sample(-s) tested (dimensions, shape, etc.) and reference to its marking (if any)
- h) surface structure (e.g. smooth, profiled, structured, ...)
- i) description of conditioning and preparation of the sample (if any)
- j) the speed of applying the load
- k) description of test conditions (temperature and RH)
- l) test loads attained during the tests together with the corresponding deformations at all measurement positions; the vertical loads F_v applied in the racking stiffness and strength tests;
- m) values of R and F_{max} and the circumstances in which F_{max} occurred;
- n) gap between the sheets in the panel (if any);
- o) direction of greater strength of the sheathing material;
- p) specification of the mechanical fasteners (including corrosion protection), and their quantity and positioning;
- q) description of the method of loading the panel and of measuring the panel deformations;
- r) type and position of any failure, including failures that have no relationship with the racking resistance of the panel (e.g. failure of the connection to the substrate).

ANNEX B – DESCRIPTION OF THE KIT AND ITS COMPONENTS

B.1 Sandwich panel

B.1.1 Dimensions of the panel

All the panels of the kit have the same basic design: double skin steel sheets with an injected insulation PUR core.

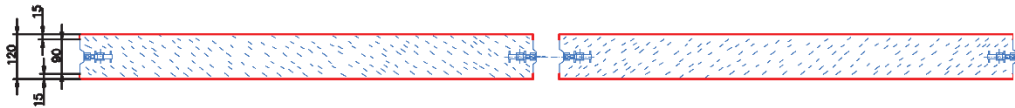

Figure B.1.1.1: Horizontal cross-section of two panels 120 mm thick.

The dimensions of the panel are specified in table B.1.1:

Dimension	Value (mm)
Thickness of panel	70 to 120
Thickness of steel sheet	0,40 to 1,20
Width of panel	100 to 1.200
Maximum length of panel	4.300 for structural uses 6.000 for non-structural uses

Table B.1.1: Dimensions of the panel.

B.1.2 Core material

Polyurethane foam is the material used in the core of the panel.

- Density (kg/m^3): between 46 and 63.

B.1.3 Face materials

Metal faces of the panel are made of steel sheets according to EN 10346.

B.2 Fixing system

The interlocking system is based on a rotating steel hook contained in the panel that locks on a steel axis contained in the second panel, and clamps the two panels together.

The system is operated by means of a manual key trough a small hexagonal hole on the inner surface of the panels.

The hook and the axis are made of steel. Both are located on a high-resistance ABS (acrylonitrile butadiene styrene) casing with a cone-shape.

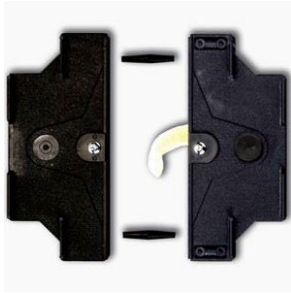

Figure B.2.1: Fixing system “JIGS” detail.

B.3 Profiles

The profiles are made of galvanized steel according to EN 10346.