



EUROPEAN ASSESSMENT DOCUMENT

EAD 340308-00-0203

January 2019

TIMBER BUILDING KITS

The reference title and language for this EAD is English. The applicable rules of copyright refer to the document elaborated in and published by EOTA.

This European Assessment Document (EAD) has been developed taking into account up-to-date technical and scientific knowledge at the time of issue and is published in accordance with the relevant provisions of Regulation (EU) No 305/2011 as a basis for the preparation and issuing of European Technical Assessments (ETA).

Contents

1	Scope of the EAD	4
1.1	Description of the construction product	4
1.1.1	The kit	4
1.2	Information on the intended use(s) of the construction product	5
1.2.1	Intended use(s)	5
1.2.2	Working life/Durability	5
1.3	Specific terms used in this EAD	5
1.3.1	Components	5
1.3.2	Design climatic conditions	5
1.3.3	Elements (main building elements)	5
1.3.4	Joint or connection	6
1.3.5	Pre-designed	6
1.3.6	Production in series	6
1.3.7	Separating walls and floors	6
1.3.8	Two-stage principle	6
1.3.9	Wet area	6
2	Essential characteristics and relevant assessment methods and criteria	7
2.1	Essential characteristics of the product	7
2.2	Methods and criteria for assessing the performance of the product in relation to essential characteristics of the product	8
2.2.1	Resistance, stability and stiffness of wall, floor and roof structures and their connections against vertical and horizontal loads	8
2.2.2	Shear resistance in plane direction against horizontal loads	9
2.2.3	Compression resistance - log walls	9
2.2.4	Settling of construction – log walls	10
2.2.5	Corrosion protection of metal fasteners	11
2.2.6	Reaction to fire of components (materials)	11
2.2.7	Resistance to fire	11
2.2.8	External fire performance of roofs	12
2.2.9	Water vapour resistance	12
2.2.10	Watertightness	13
2.2.11	Durability class/ use class	15
2.2.12	Content, emission and/or release of dangerous substances	15
2.2.13	Impact resistance	16
2.2.14	Airborne sound insulation of walls, floors and roof structures	17
2.2.15	Impact sound insulation of floors	17
2.2.16	Sound absorption	17
2.2.17	Thermal resistance and thermal transmittance	17
2.2.18	Air permeability	18
2.2.19	Thermal inertia	19
3	Assessment and verification of constancy of performance	20
3.1	System of assessment and verification of constancy of performance to be applied	20
3.2	Tasks of the manufacturer	20
3.3	Tasks of the notified body	22
4	Reference documents	23
	Annex A - Description of the kit	26
	Annex B - Watertightness of log walls Applying the testing standard EN 1027	33
	Annex C - Determination of impact resistance of panels and panel assemblies	36

1 SCOPE OF THE EAD

1.1 Description of the construction product

1.1.1 The kit¹

This EAD covers industrially prepared timber-based building kits, made of predesigned and prefabricated main building elements intended for production in series. The main building elements of the kits are wall, floor and roof structures. Annex A, Figures A.1 to A.3 are showing examples of general design and section build-up of main building elements of the kits.

The parts in a kit may be manufactured as pre-cut timber members, logs or prefabricated structural elements supplemented with additional materials on site, as completely prefabricated two-dimensional building elements, or as building modules where the floors, walls and roof are connected in the factory. Components may be connected by suitable structural adhesives or by mechanical fixing.

The timber building kit covered by this EAD may be supplied with varied degrees of completion but minimum content of the kit to be assessed shall include following elements and components:

- all structural elements necessary for the stability of the building including walls, floors, roof structures, their connections, and the connections of the building to the substructure.
- all components of the external envelope including all thermal insulation, fire protection, vapour control provisions and external waterproofing.
- all components of the internal walls (loadbearing and non-loadbearing) including acoustic insulation, internal linings and fire protection
- preparatory devices/equipment for the installation of plumbing, heating, cooling, ventilation and electrical services, where applicable.

Components such as windows, external doors, brick cladding, internal linings and roofing materials, which are essential for the performance of the external envelope, may or may not be part of the kit. In cases where these components do not form part of the kit then the connections and detailing of the interface between such components and the kit shall be specified in the ETA.

Service installations and complementary structures (including foundations or substructures) are not covered by this EAD.

The timber building kit shall be clearly described in ETA by the specification of components (materials) and elements. Components specification may be presented by a table, see example in Annex A, Table A.1. The main building elements shall be specified by significant drawings (section drawing) and description see example Annex A, Figures A.1 to A.3 and Table A.2.

The product is not covered by a harmonised European standard (hEN).

Concerning product packaging, transport, storage, maintenance, replacement and repair it is the responsibility of the manufacturer to undertake the appropriate measures and to advise his clients on the transport, storage, maintenance, replacement and repair of the product as he considers necessary.

It is assumed that the product will be installed according to the manufacturer's instructions or (in absence of such instructions) according to the usual practice of the building professionals.

Relevant manufacturer's stipulations having influence on the performance of the product covered by this European Assessment Document shall be considered for the determination of the performance and detailed in the ETA.

¹ "Kit" means a construction product placed on the market by a single manufacturer, as a set of at least two separate components that need to be put together to be incorporated in the construction works (Art.2 n°2 CPR).

1.2 Information on the intended use(s) of the construction product

1.2.1 Intended use(s)

The timber building kits can be used for low-rise and multi-storey residential, institutional, commercial and industrial buildings where timber-based construction is applicable.

Kits covered by this EAD are also intended be used in areas of seismic actions.

Depending on the type the timber building kits can be considered as low-dissipative or dissipative structures, defined according to Eurocode 8 (EN 1998-1:2004) Clause 1.5.2.

1.2.2 Working life/Durability

The assessment methods included or referred to in this EAD have been written based on the manufacturer's request to take into account a working life of the timber building kit for the intended use of 50 years for the loadbearing structure and for non-accessible components and materials, and 25 years for repairable or replaceable components and materials such as claddings, roofing materials, exterior trims, and integrated components such as windows and doors. These provisions are based upon the current state of the art and the available knowledge and experience.

When assessing the product, the intended use as foreseen by the manufacturer shall be taken into account. The real working life may be, in normal use conditions, considerably longer without major degradation affecting the basic requirements for works².

The indications given as to the working life of the construction product cannot be interpreted as a guarantee neither given by the product manufacturer or his representative nor by EOTA when drafting this EAD nor by the Technical Assessment Body issuing an ETA based on this EAD but are regarded only as a means for expressing the expected economically reasonable working life of the product.

1.3 Specific terms used in this EAD

1.3.1 Components

Components used in this EAD are parts of the main building elements such as wood-based boards, gypsum boards, foils, nails and similar.

1.3.2 Design climatic conditions

Outdoor and indoor air temperatures and moisture levels, snow loads, wind speed levels, etc, which may be stated in national building regulations or in other specifications to be used for design are known as "design climatic conditions".

1.3.3 Elements (main building elements)

Elements used in this EAD are parts of the kit such as wall, floor and roof structures.

² The real working life of a product incorporated in a specific works depends on the environmental conditions to which that works is subject, as well as on the conditions of the design, execution, use and maintenance of that works. Therefore, it cannot be excluded that in certain cases the real working life of the product may also be shorter than referred to above.

1.3.4 Joint or connection

A joint or connection is a junction between two components, elements or other parts of a building.

1.3.5 Pre-designed

'Pre-designed' is defined as pre-determined technical solutions.

1.3.6 Production in series

Production of building kits for a series of buildings based on the same, or similar materials, structural design and construction details is known as production in series. The buildings and components do not have to be exactly the same size or shape.

1.3.7 Separating walls and floors

Walls and floors are described as 'separating' where e.g. sound insulation – and /or fire resistance performance, requirements may be requested.

1.3.8 Two-stage principle

The two-stage principle is a design principle for claddings, joints, etc in the exterior envelope. An outer layer serves to protect an inner layer from direct driving rain and sun radiation. The space between these layers is ventilated and drained.

1.3.9 Wet area

A wet area is defined as a floor or wall area in a bathroom or other "wet room" where the surface may be exposed to water spray from showers, etc.

2 ESSENTIAL CHARACTERISTICS AND RELEVANT ASSESSMENT METHODS AND CRITERIA

Note: All undated references to standards or to EADs in this chapter are to be understood as references to the dated versions listed in Clause 4.

2.1 Essential characteristics of the product

Table 1 shows how the performance of the timber building kit is assessed in relation to the essential characteristics.

Table 1 Essential characteristics of the product and methods and criteria for assessing the performance of the product in relation to those essential characteristics

No	Essential characteristic	Assessment method	Type of expression of product performance
Basic Works Requirement 1: Mechanical resistance and stability			
1	Resistance, stiffness and stability of wall, floor and roof elements and their connections against vertical and horizontal loads	2.2.1	Description
2	Shear resistance in plane direction against horizontal loads	2.2.2	Level
3	Compression resistance - log walls	2.2.3	Level
4	Settling of construction of log	2.2.4	Description
5	Corrosion protection of metal fasteners	2.2.5	Class
Basic Works Requirement 2: Safety in case of fire			
6	Reaction to fire of materials and components	2.2.6	Class
7	Resistance to fire	2.2.7	Class
8	External fire performance of roof covering	2.2.8	Class
Basic Works Requirement 3: Hygiene, health and the environment			
9	Water vapour resistance	2.2.9	Level
10	Watertightness	2.2.10	Description, Level
11	Durability class/ use class	2.2.11	Class, Description
12	Content, emission and/or release of dangerous substances	2.2.12	Level
Basic Works Requirement 4: Safety and accessibility in use			
13	Impact resistance	2.2.13	Description, Level

No	Essential characteristic	Assessment method	Type of expression of product performance
Basic Works Requirement 5: Protection against noise			
14	Airborne sound insulation of walls, floors and roof structures	2.2.14	Description, Level
15	Impact sound insulation of floors	2.2.15	Description, Level
16	Sound absorption	2.2.16	Level
Basic Works Requirement 6: Energy economy and heat retention			
17	Thermal resistance	2.2.17	Level
18	Air permeability	2.2.18	Description, Level
19	Thermal inertia	2.2.19	Level

2.2 Methods and criteria for assessing the performance of the product in relation to essential characteristics of the product

This chapter is intended to provide instructions for TABs. Therefore, the use of wordings such as “shall be stated in the ETA” or “it has to be given in the ETA” shall be understood only as such instructions for TABs on how results of assessments shall be presented in the ETA. Such wordings do not impose any obligations for the manufacturer and the TAB shall not carry out the assessment of the performance in relation to a given essential characteristic when the manufacturer does not wish to declare this performance in the Declaration of Performance.

Testing will be limited only to the essential characteristics which the manufacturer intends to declare. If for any components covered by harmonised standards or European Technical Assessments the manufacturer of the component has included the performance regarding the relevant characteristic in the Declaration of Performance, retesting of that component for issuing the ETA under the current EAD is not required.

2.2.1 Resistance, stability and stiffness of wall, floor and roof structures and their connections against vertical and horizontal loads

Indication of geometrical data of the components and elements and their properties related to mechanical resistance and stability shall be used as an expression of resistance, stability and stiffness of wall, floor and roof elements against vertical and horizontal loads.

Load-bearing walls

For timber frame walls, the standard parts of the structural elements shall be defined by frame cross section, spacing and sheeting. The strength of the timber and timber-based material shall be given by reference to the strength class according to harmonized European standards e.g. EN 14080, EN 14081-1 (EN 338), EN 15497 or to ETAs e.g. light composite wood-based beams and columns.

For walls made of cross laminated timber (CLT) the thickness and number of layers shall be defined together with the strength class of lamellas according to EN 14081 -1 (EN 338) or as strength properties of CLT. In case laminated veneer lumber (LVL) is used, the thickness, strength and stiffness properties shall be defined according to EN14374.

For log walls, the overall cross section of the logs shall be clearly defined (timber species, type (solid, glued), thickness, depth and overall shape). The strength of the timber material shall be given, preferably by reference to the strength class according to EN 14081-1 (EN 338), EN 14080 or to other harmonised

technical specifications. Relevant fasteners for assembling the walls should also be defined by type, number and spacing. If adhesives are used, the type and full classification according to EN 301, Table 1 or EN 15425, Table 1 shall be given in the ETA.

Floors and roof structures

For timber beam structure, the standard load bearing components shall be defined by cross section, spacing and maximum span. The strength of the timber and timber-based materials shall be given by reference to the strength class according to harmonized European standards eg. EN 14080, EN 14081-1 (EN 338), EN 15497 or to ETAs e.g. light composite wood-based beams and columns.

For floor and roof elements made of cross laminated timber (CLT) the thickness and number of layers shall be defined together with the strength class of lamellas according to EN 14081-1 (EN 338) or as strength properties of CLT. For floors and roofs made of laminated veneer lumber (LVL) the thickness, strength and stiffness properties shall be defined according to EN14374.

For other construction types, corresponding geometry / material information shall be given.

Any load bearing components at floor or roof openings shall be described correspondingly.

Relevant fasteners for assembling the floor and roof structures shall also be defined by type, number and spacing. If adhesives are used, the type and full classification according to EN 301 Table 1 or EN 15425 Table 1 shall be given in the ETA.

Other structural components

If the other standard components as e.g. beams and posts are included in the kit, they shall be specified by relevant dimensions and strength properties or by characteristic design values.

Note: The described method above is used to provide the basis for case by case calculations, according to EN 1990, EN 1991, EN 1995-1-1, EN 1998-1. Testing according to relevant product standards or by a combination of both (design assisted by testing) is also possible.

2.2.2 Shear resistance in plane direction against horizontal loads

Shear resistance and stiffness of wall shall be determined by racking test of walls according to EN 594. Frame fixing should be as used by producer in practice or bolted. Shear resistances are normally specified for the standard wall sections (2.4x2.4m) without openings but can also be given for producer specified wall heights.

Shear resistance in plane direction shall be given in the ETA as racking stiffness [N/mm] and racking strength [kN] together with the detailed information about the dimensions of specimens (if different from standard sections), type of fixing and level of vertical loading).

The strength and stiffness of wood dowels, notched corners and other joints shall be tested according to EN 26891 (ISO 6891) and shall be given in the ETA.

2.2.3 Compression resistance - log walls

Compression resistance of walls shall be assessed based on full-scale compression test which leads to buckling out of plane failure type. The test wall shall have the bracing elements specified for the product (corners, etc.). Height of a test wall is about 3m and distance between corners shall be at least 4m. Length of the cross-walls is the minimum length of corners in the specification of the product. Separate tests shall be done at least for the minimum and maximum dimensions of each different log type.

Test wall shall be loaded by uniform line load with eccentricity of at least $H/300$; short-term test up to failure according to loading procedure of EN 26891. If only single tests are used, the characteristic resistance $F_{C,k}$ specified in ETA is at the maximum $0,83$ x the test result.

The following properties of the log construction shall be specified in ETA:

- The compressive resistance $F_{C,k}$ of the log wall against vertical loads is $F_{W,k} + n \cdot F_{CC,k}$

Where

- Characteristic compression capacity $F_{W,k}$ of the wall for an eccentric vertical load $F_{W,k} = \min(L; 4m) \cdot b_{ef} \cdot 1,0 \text{ N/mm}^2 \text{ [kN]}$
 $b_{ef} = \frac{3}{4}$ nominal thickness of planed or laminated logs and $\frac{1}{2}$ for round logs [mm]
 $L = \text{length of the wall [m]}$
- The characteristic compression capacity $F_{CC,k}$, with each corner type / other bracing elements $F_{CC,k} = 0,6m \cdot b_{ef} \cdot 1,0 \text{ N/mm}^2 \text{ [kN]}$.
- $n = \text{number of bracing cross corners}$
- Max distance between bracing corner / other bracing elements of the product, however, not more than 8m
- The height of the wall is not more than 3 m
- Dowelling system: wood dowels, steel pipes, threaded bars or screws, sizes, holes, max. spacing

2.2.4 Settling of construction – log walls

Log house walls are settling in vertical direction after construction due to drying of the logs. The amount of the settling is influenced by the way of installation and the final moisture content (MC%) of the structures compared with the moisture content during installation.

A requirement of the maximum initial moisture content MC% at the manufacture is 24% for monolithic logs and 18% for laminated logs. The settling is assessed based on calculation:

Settling [mm/m] = Shrinkage factor [mm/(m*ΔMC%)] * (MC% during installation - MC% of the final structure).

Unless a more detailed assessment is made, shrinkage factor is 3 mm/(m*ΔMC%) for round logs and 2,5 mm/(m*ΔMC%) for planed and laminated logs.

Settling [mm/m] of each log type shall be given in the ETA.

The settling of a log house shall be taken into account in the assessment of at least the following detailing:

- Sliding supports on the walls for roof beams
- Door and window openings
- The settling must not be prohibited by any constructions even if they are not a part of the kit
- Adjustable screw foot connections for columns, removal of possible adjustment bits, etc. They shall be used as described in the construction manual

In the detailing at least the following level of settling shall be taking into account:

- Round logs 30mm/m
- Massive logs 20mm/m
- Laminated logs 15 mm/m
- Non-settling logs 5mm/m

2.2.5 Corrosion protection of metal fasteners

Corrosion protection of metal fasteners corresponds to the requirements of the intended service class (see EN 1995-1-1, Table 4.1 and the corresponding reference standards).

Following assessments of metal fasteners is performed to determine the thickness of corrosion protection or the material specification:

- If a zinc coating is used its thickness is determined by:
 - hot-dip galvanized coating to EN ISO 1461, using the methods described in the standard, using the non-destructive magnetic method of EN ISO 2178, or using the gravimetric method of EN ISO 1460 as a reference method in case of dispute,
 - hot-dip zinc-coated sheet to EN 10346 using the non-destructive magnetic method of EN ISO 2178, or using the methods described in Annex A of the standard in the case of dispute,
 - electroplated zinc coating to EN ISO 2081 table C1, using the methods described in the standard, or using EN ISO 2177 as a reference method in case of dispute.
- If stainless steel is used, it shall be designated in accordance with EN 10088-1.
- If aluminium is used, it shall be designated in accordance with an appropriate standard.
- Alternative corrosion protection materials are assessed in accordance with the principles in FprEN 14592:2018-02 section 5.2.

2.2.6 Reaction to fire of components (materials)

The components shall be classified using one of the cases listed below.

Case 1: Construction products and/or materials (components) without the need for testing (CWFT).

The components are considered to satisfy the requirements for performance class of the characteristic reaction to fire, in accordance with the relevant Commission Decision without the need for testing. The used Commission Decision regarding the components and/or the harmonised product standard shall be stated in the ETA (see example in Annex A, Table A.1).

Case 2: Components satisfying the requirements for the fire reaction class A1, without the need for testing.

The components are considered to satisfy the requirements for performance class A1 of the characteristic reaction to fire, in accordance with the provisions of EC decision 96/603/EC (as amended) without the need for testing on the basis of their listing in that Decision.

Components with fire reaction class A1 and/or the harmonised product standard shall be stated in the ETA (see example in Annex A, Table A.1).

Case 3: Components not covered by Case 1 or Case 2.

The components shall be tested, using the test method(s) relevant for the corresponding reaction to fire class according to EN 13501-1, and classified according to delegated regulation (EU) 2016/364.

The classes of the components shall be stated in the ETA (see example in Annex A, Table A.1).

2.2.7 Resistance to fire

Resistance to fire can be assessed by calculation in accordance with EN 1995-1-2 or testing. Tests shall be done on the on the element with the foreseen lowest resistance to fire (smallest dimensions of cross section within the same type of element) for given class according to the test methods specified in EN 13501-2. Other units may be evaluated to these test results. In case of testing fire resistance, load-bearing

values and performance parameters considered in the test procedure shall be given in the ETA.. The resistance to fire performance shall be tested and classified according to EN 13501-2.

The range of classifications according to EN 13501-2 is applicable.

Note: For load bearing building elements with a calculated resistance R to fire, the mechanical resistance when exposed to fire shall be given in accordance with EN 1991-1-2 and EN 1995-1-2 (using flow chart given in Annex F), as well as the provisions in clause 2.2.1.

2.2.7.1 Resistance to fire of log walls

Resistance to fire of log walls shall be assessed according to the test methods specified in EN 13501-2. In addition to the information required in EN 13501-2, the following essential information about the structure shall be specified to in the ETA:

- Log type (size and profile, tongue length is an essential dimension in the profile, strength class)
- Sealant type (material and profile)
- Dowelling system: wood dowels, steel pipes, threaded bars or screws, sizes, holes, max. spacing
- Corner type: profile, sealant type, connectors
- Max distance between bracing elements

The resistance to fire is expressed in the ETA as EI or REI class with the maximum level of vertical design load kN/m and possible eccentricity for structural fire design.

2.2.8 External fire performance of roofs

The roof covering shall be classified using one of the cases below.

Case 1: Roof covering is classified without the need for testing (CWT)

The roof covering is considered to satisfy the requirements for performance class of the characteristic external fire performance in accordance with the relevant Commission Decision without the need for testing on the basis of its conformity with the specification of the roof covering detailed in that Decision and its intended end use application being covered by that Decision. The used Commission Decision and/or the harmonised product standard of the roof covering shall be stated in the ETA (see example in Annex A, Table A.1).

Case 2: Roof covering is satisfying the requirements for the external fire performance, due to the deemed to satisfy list

The roof covering is considered “deemed to satisfy” for external fire performance without the need for testing on the basis that it is included within the definitions given in Commission Decision 2000/553/EC. The performance of the relevant roof covering shall be stated in the ETA (see example in Annex A, Table A.1).

Case 3: Roof covering not covered by Case 1 or 2

The roof covering shall be tested using the test method relevant for the corresponding external fire performance roof class, to be classified according to EN 13501-5 and taking into account what the manufacturer intends to declare.

2.2.9 Water vapour resistance

Assessment of the relevant building parts, including wet room envelopes, shall be undertaken based on calculations according to EN ISO 13788, taking into account the relevant design climatic conditions.

The assessment is undertaken with respect to both interstitial and internal surface condensation. The performance of the kit may be stated in the form of acceptable intended uses relevant to the design climatic conditions, e.g. types of buildings and geographical zones.

The assessment of interstitial or internal surface condensation risk shall be based on the assumption that growth of micro-organisms is avoided if humidity in the timber structures inside the external sheathing or breather membrane only exceeds 80% RH for limited periods of time at design climatic conditions.

The risk of condensation can normally be verified on the basis of hygrothermal characteristics of the products used in each component and the construction details.

The water vapour resistance of the water vapour control layer inside the thermal insulation and of the breather membrane or wind barrier outside the thermal insulation shall be specified. The water vapour resistance for internal watertight membranes or surface layers in bathrooms shall also be specified.

The water vapour resistance of the relevant layers should be based upon:

- Design values given in EN ISO 10456 or declared in the DoP in accordance with harmonised technical specifications.

or

- Tests according to EN ISO 12572 or declared in the DoP in accordance with harmonised technical specifications.

In addition, the design of joints and any fixings/services penetrating any vapour control element or membrane shall be assessed in relation to the risk of airborne moisture coming into contact with cold surfaces within the construction.

Assessment of condensation risks due to low surface temperatures or air leaks is given in clauses 2.2.17-2.2.19.

Moisture resistance of materials in terms of durability is covered under clauses 2.2.5 and 2.2.11

2.2.10 Watertightness

2.2.10.1 External envelope

The ability of the external building envelope to resist water leakages from precipitation, including driving rain on facades and possibly snow penetration, shall be assessed on the basis of the standard construction details for the kit. The standard construction details have to cover the whole external building envelope (roofs and walls), including joints between elements in the kit (e.g. external wall corner, connection between external wall and roof element) and other structural joints within the kit and to other building parts. (e.g. to windows, substructures).

The external envelope may generally be regarded as sufficiently watertight (not causal for any moisture damages) when following principles are applied:

- The external envelope is designed according to the two-stage principle (e.g. wooden façade and flexible sheet for waterproofing, roof covering and flexible sheet for waterproofing)

Examples for construction details including connections, materials and general workmanship can be found in following standard literature:

- Fassaden aus Holz (Wooden Facades), Chapter 11
- Manual of Multi-Storey Timber Construction Chapter C
- Systems in Timber Engineering; Chapter C1
- www.dataholz.eu - Catalogue of wood and wood-based composite materials, building materials, components and component connections (Chapter Component connections)
- Håndbok 5 Trehus – Timber houses, Chapter 5.2. External walls
- SINTEF Byggforsk Byggdetalj 542.003 - Totrinnstetning mot slagregn på fasader. Luftede kledninger og fuger (the two-stage principle against driving rain on facades)

- The façade system is in accordance to EAD 040089-00-0404 for ETICS.

For external envelope designed without a ventilated air space, watertightness may also be assessed based on laboratory testing. Two equivalent test methods can be used:

1) EN 12865

Resistance to driving rain under pulsating pressure is tested in accordance with EN 12865, procedure A. The dimensions of the test specimen shall be as large as necessary to be presentative of the intended use, but not less than:

- Width ~1200 mm
- Height ~2400 mm

The watertightness of external envelope and joints in the kit when tested in accordance with EN 12865 shall be determined as the limit of watertightness expressed in Pascals.

or

2) EN 1027

Watertightness of walls shall be assessed by applying the testing standard EN 1027.

Test specimen and test setup

Watertightness of wall structures shall be assessed on straight wall specimen including joints between prefabricated elements and components in the kit. Test specimen size shall be:

- Height 2000-2200 mm
- Length 2000mm including joints between prefabricated elements/components in the kit

Test procedure

Air pressure and water spraying of the test setup are specified in EN 1027. Spraying is applied first with the test pressure of 0 Pa for 15 min. After that in addition to the water spraying, air pressure is increased from 0 Pa up to 300 Pa with steps of 50 Pa and from 300 Pa up to 1200 Pa by steps of 150 Pa. Each step takes at least 5 min to achieve the specified air pressure.

The test conditions are specified in Clause 7.1 of EN 1027 standard.

Expression of the results

Pressure levels when water leakages start, and locations of the leakages shall be recorded.

After the test the specimen structure shall be dismantled, and wet areas shall be marked.

In case of water absorbing sealant material, the amount of water is measured by weighting before and after the test.

Watertightness class shall be given in the ETA according to the classification standard EN 12208.

2.2.10.2 Watertightness of log walls

Watertightness of log walls shall be assessed by applying the testing standard EN 1027 as described in Annex B.

Watertightness class shall be given in the ETA according to the classification standard EN 12208.

2.2.10.3 Internal surfaces

The performance of watertight membranes or surface layers in wet areas of bathrooms shall be assessed on the basis of the provisions in EAD 030352-00-0503 *Watertight covering kits for wet room floors and or walls*.

It shall be indicated in the ETA which parts of the kit are classified as watertight face areas.

2.2.11 Durability class/ use class

The most important aspects related to the durability of timber building kits are:

- Biological degradation of timber material by fungi as a result of excessive moisture content
- Degradation of wood materials by insects
- Degradation of glued joints and glued components

The intended working life of 50 years for the load-bearing structure and for non- accessible components and materials, and 25 years for repairable or replaceable components and materials, is achieved if:

- The moisture content of the timber as expressed by the service class according to EN 1995-1-1 (cl. 4.1.) corresponds to the durability class of the timber (see corresponding reference standards for durability of wood).
- Wood material exposed to external climate has the ability to dry between wetting periods in a way that keeps the overall mean moisture content of the wood below 20 %.
- Sufficient measures against insects have been taken into account. This may imply areas where insects are a problem. When chemical treatment is used, the treatment shall be specified by: type of treatment and preservative, target biological agents, penetration class and retention value.
- Glued joints and glued components have been manufactured, tested and found satisfactory according to requirements for the relevant service class and the relevant standards.

Assessment may be given either in terms of durability classes or in the way of description of the product (e.g. preservative treatment).

2.2.12 Content, emission and/or release of dangerous substances

The performance of the kit related to the emissions and/or release and, where appropriate, the content of dangerous substances will be assessed on the basis of the information provided by the manufacturer³ after identifying the release scenarios taking into account the intended use of the product and the Member States where the manufacturer intends his product to be made available on the market.

The identified intended release scenarios for this product and intended use with respect to dangerous substances are:

IA1: Product with direct contact to indoor air.

IA2: Product with indirect contact to indoor air (e.g. covered products) but possible impact on indoor air.

³ The manufacturer may be asked to provide to the TAB the REACH related information which he must accompany the DoP with (cf. Article 6(5) of Regulation (EU) No 305/2011).

The manufacturer is **not** obliged:

- to provide the chemical constitution and composition of the product (or of constituents of the product) to the TAB, or
- to provide a written declaration to the TAB stating whether the product (or constituents of the product) contain(s) substances which are classified as dangerous according to Directive 67/548/EEC and Regulation (EC) No 1272/2008 and listed in the "Indicative list on dangerous substances" of the SGDS.

Any information provided by the manufacturer regarding the chemical composition of the products may not be distributed to EOTA or to TABs.

SVOC and VOC

For the intended use covered by the release scenario IA1/IA2 semi-volatile organic compounds (SVOC) and volatile organic compounds (VOC) are to be determined in accordance with EN 16516. The loading factor to be used for emission testing is 1,0 m²/m³. Only these parts of the product with skins made of oriented strand boards (OSB), particle boards or high-pressure decorative laminates (HPL) have to be tested. For the test specimen all parts of the product up to the vapour barrier - inclusive internal linings and surface coverings which may be part of the kit have to be considered. *If phenolic foam or urea-formaldehyde (UF) in-situ foam should be used for timber constructions, it has to be tested itself without any cladding.*⁴

The preparation of the test specimen is performed by using a sample of the kit representing ETA installed in accordance with the manufacturer's product installation instructions or in absence of such instructions the usual practice of the product installation. The size of the test specimen has to be chosen in consideration of the test chamber size and the intended loading factor (see above).

Note: The described specimen can only be used when phenolic foam or urea-formaldehyde (UF) in-situ foam is not used.

As stated in the EN 16516, product samples shall be collected at the point of manufacture after the normal production processes are completed (including drying or curing if applicable) and immediately be placed in the emission test chamber⁵. This time is considered the starting time of the emission test.

The test results have to be reported for the relevant parameters (e.g. chamber size, temperature and relative humidity, air exchange rate, loading factor, size of test specimen, conditioning, production date, arrival date, test period, test result) after 3 and/or 28 days testing.

The product performance shall be expressed in [$\mu\text{g}/\text{m}^3$ or mg/m^3] and stated in the ETA.

2.2.13 Impact resistance

Mechanical resistance against impact loads shall be assessed related to the intended use.

Timber walls with well-known internal lining materials, such as standard gypsum boards, wood-based panel products and solid timber boards shall generally be accepted to have a satisfactory impact resistance for use in residential buildings, office buildings etc. in categories I-III, as defined in the EAD 210005-00-0505, table 2, as long as the deemed to satisfy conditions are met:

- Stud (timber C18/GL20) spacing ≤ 0.65 m
- Minimum thickness of internal board lining:
 - o Particleboard type P2-7 ($\rho \geq 600 \text{kg}/\text{m}^3$): $t \geq 10$ mm,
 - o Plywood ($\rho \geq 450 \text{kg}/\text{m}^3$): $t \geq 8$ mm,
 - o OSB/2-4 ($\rho \geq 600 \text{kg}/\text{m}^3$): $t \geq 10$ mm,
 - o Gypsum plasterboard/fibreboard ($\rho \geq 800 \text{kg}/\text{m}^3$): $t \geq 10$ mm,
 - o Solid wood lining ($\rho \geq 400 \text{kg}/\text{m}^3$): $t \geq 10$ mm,
 - o MDF ($\rho \geq 600 \text{kg}/\text{m}^3$): $t \geq 10$ mm.

Log walls have a satisfactory impact resistance for use in residential buildings, office buildings etc. in categories I-III, as defined in the EAD 210005-00-0505, Table 2.

In cases where the wall elements structure does not satisfy above listed conditions, the impact resistance shall be tested. Testing of walls and ceilings is undertaken according to Annex C. Floors and roofs are tested according to EN 1195.

⁴ Usually these insulation materials will not be used for timber constructions.

⁵ If specified in the relevant product standard a conditioning period shall be applied to test specimens before starting the test to enable the product to acquire properties representing in use conditions.

With walls soft body impact and hard body impact shall be assessed according to Annex C (Clause C.2 and C.3), taking into consideration serviceability impact resistance and safety in use impact resistance.

Results shall be expressed as energy of hard and soft body impact (Annex C, Clause C.4) and as description of safety in use and serviceability criteria (Annex C, Clause. C.2.7 and C.3.7).

2.2.14 Airborne sound insulation of walls, floors and roof structures

The airborne sound insulation (between rooms, of facades and of roofs) of the main building elements of the assembled kit shall be assessed by laboratory tests according to EN ISO 10140-1, 2, 4 and 5 (laboratory tests). The rating of airborne sound insulation shall be undertaken according to EN ISO 717-1.

The airborne sound insulation may also be assessed by references to data for common timber construction designs, provided that such data are based upon tests and classification in accordance with the EN ISO standards mentioned above.

The airborne sound insulation for walls, floors and roofs, as relevant, shall be given in the ETA, as weighted sound reduction index R_w (C; C_{tr}) according to EN ISO 717-1.

Other designations indicated in EN ISO 717-1 may be added in the ETA.

2.2.15 Impact sound insulation of floors

The impact sound insulation of the floors of the assembled kit shall be assessed by laboratory tests according to EN ISO 10140-1, 3, 4 and 5 (laboratory tests), and the rating of impact sound insulation shall be undertaken according to EN ISO 717-2.

The impact sound insulation may also be assessed by references to data for common timber construction designs (for example www.dataholz.eu), provided that such data are based upon tests and classification in accordance with the ISO standards mentioned above.

Assessments of impact sound insulation performance may be supplemented by indicative field testing of building structures.

The impact sound insulation for floors, as relevant, shall be specified in the ETA, as weighted normalized impact sound pressure level $L_{n,w}$, according to EN ISO 717-2.

Other designations indicated in EN ISO 717-2 may be added in the ETA.

2.2.16 Sound absorption

The sound absorption performance of internal surfaces, when specified, shall be assessed by laboratory tests according to EN ISO 354.

The measured acoustic absorption coefficient shall be expressed as a single number rating α_w in accordance with EN ISO 11654.

2.2.17 Thermal resistance and thermal transmittance

Thermal resistance (R-value) and the corresponding thermal transmittance (U-value) of the main building elements of the assembled kit shall be calculated according to EN ISO 6946.

Thermal resistance values for the main building elements of the assembled kit shall be calculated as the total thermal resistance R_{tot} in m^2K/W . The thermal resistance shall be a value covering homogenous and inhomogeneous layers, including the effect of studs, joists, etc based on a mean length in relation to 1 m^2 of the building part.

The thermal transmittance U in $W/(m^2K)$ for the main building elements to be given in the ETA, shall be rounded to two significant figures.

Corrections to the thermal transmittance, as appropriate to the building element concerned, shall be calculated in accordance with EN ISO 6946 Annex F.

If the design has technical solutions with special thermal bridging not covered by the ordinary assessment of the thermal resistance as mentioned above, the assessment may be undertaken by calculations according to EN ISO 10211 or by testing according to EN ISO 8990.

For insulation products not produced by the manufacturer of the kit, the thermal conductivity declared in the DoP of their manufacturer (according to harmonized product standards or according to an ETA if available) shall be used for the calculations. For other components the design thermal conductivity values for materials according to EN ISO 10456 can be used. If the thermal resistance is not given as above it may be assessed by testing according to EN ISO 8990.

The insulation products shall be specified and the thermal conductivities of the materials shall be given in $W/(mK)$ in the ETA.

The thermal transmittance of windows and doors shall be given in accordance with EN 14351-1.

For walls made of logs the calculations can be based on an assumed homogeneous wood section where the thickness is equal to the maximum log thickness for rectangular logs. For round logs the area-equal thickness may be used. Effects of seals or cracks are neglected.

2.2.18 Air permeability

Assessment of the air permeability of the external envelope shall consider joints between components in the kit and, if relevant, joints between the kit and other building parts.

Joints in timber constructions may generally be regarded as sufficiently airtight when the following principles are applied:

- Overlapped joints of plastic films, breather paper or similar roll products continuously clamped by parallel timber members or by panel products

or

- Joints filled with a building sealant or foam protected from direct weathering and with movements in the joint limited by mechanical fasteners.

An airtightness concept of the building envelope shall be described in ETA.

A general statement in qualitative terms of air tightness, based on the assessment of construction details and kit components shall be given in the ETA with regard to unintended ventilation, cold draughts and risks of water vapour condensation inside the construction.

Note: Realized tests according to EN ISO 9972 of already built kits with the same airtightness concept can be used in the assessment process.

Air permeability can be also assessed based on laboratory testing.

- EN 12114

Air permeability of joints in the connections between the elements in the kit shall be tested in accordance with EN 12114.

The dimensions of the test specimen shall be as large as necessary to be presentative of the intended use, but not less than:

- Width ~1200 mm
- Height ~2400 mm

Air pressure is increased from 0 Pa to 600 Pa in steps of 50, 100, 150, 200, 250, 300, 450, 600.

The air permeability of joints in the kit shall be determined as the air flow rate in volume per hour per joint meter at different levels from 50 Pa to 600Pa.

or

- EN 1026

Air permeability of components like windows and doors is assessed in accordance with EN 14351-1, clause 4.14, applying the testing standard EN 1026.

The dimensions of the test specimen shall be as large as necessary to be presentative of the intended use, but not less than:

- Width ~1000 mm
- Height ~1000 mm

The air permeability of the components when tested in accordance with EN 1026 shall be determined in classes according to the classification standard EN 12207.

2.2.18.1 Air permeability of log walls

Air permeability of log walls shall be assessed by applying the testing standard EN 1026.

Test setup and test specimen

Straight wall specimen and corner specimen shall be tested, see figures B.1 to B.4. Test specimen size shall be:

- Height 800 - 1000mm including 3 - 4 joints between layers of logs
- Length ~1200mm

Dowelling system of the product shall be specified for the test. Threaded bars may be used for tightening the log joints in the test. Their nuts should be tightened to 50 Nm moment. Corner specimen needs sealed panels on the top and bottom to make the structure tight in the test up.

Air pressure is increased from 0 Pa to 600 Pa in steps of 50, 100, 150, 200, 250, 300, 450, 600.

Expression of the results:

Airtightness class shall be given in the ETA as airflow / joint meter between the logs at different pressure levels from 50 Pa to 600 Pa and in classes according to classification standard EN 12207 for doors and windows.

2.2.19 Thermal inertia

Thermal inertia shall be assessed according to EN ISO 13786.

For the assessment of thermal inertia, the following properties of the relevant component shall be defined in the ETA (see example Annex A, Table A.1) based on product declaration of performances or on tabulated values in accordance to EN 10456:

- Thermal conductivity [W/(mK)] or thermal resistance [m²K/W],
- Density [kg/m³],
- Specific heat capacity [J/(kg/K)]

Thermal inertia assessed according to EN ISO 13786, Ch. 6 and 7, shall be expressed as internal thermal admittance (Y_{i1}), time shift on internal side (Δt_{int}) and internal areal heat capacity (κ_1).

3 ASSESSMENT AND VERIFICATION OF CONSTANCY OF PERFORMANCE

3.1 System of assessment and verification of constancy of performance to be applied

For the products covered by this EAD the applicable European legal act is: Decision 1999/455/EU

The system is: 1

3.2 Tasks of the manufacturer

The cornerstones of the actions to be undertaken by the manufacturer of the timber building kits in the procedure of assessment and verification of constancy of performance are laid down in Table 2.

Table 2 Control plan for the manufacturer; cornerstones

No	Subject/type of control	Test or control method	Criteria, if any	Minimum number of samples	Minimum frequency of control
Factory production control (FPC)					
1	Check of incoming materials/ components, including timber components used in the kit	See Table 2a	See Table 2a	See Table 2a	See Table 2a
2	Moisture content of timber components	EN 13183-2	control plan*	control plan*	each delivery
3	Production and assembling of the elements of the kit	control plan*	control plan*	control plan*	control plan*

* Control plan shall be defined in detail for each individual ETA, and controls and tests therein shall focus on the kit and not its components. Only if there is an essential characteristic the performance of which is represented only by means of the performance of a component and assessed within the Chapter 2.2, then this component can be also addressed in more detail. In any case, the control of kit components is the responsibility of the kit manufacturer.** N/A=not applicable

Table 2a Control plan for incoming materials/ components, including timber components used in the kit; cornerstones.

No	Subject/type of control	Test or control method	Criteria, if any	Minimum number of specimens	Minimum frequency of control
Factory production control (FPC)					
1	Components belonging to Case 1 (*)	(1)	Conformity with the order	Testing is not required	Each delivery
		(2)	Acc. to Control Plan	Testing is not required	Each delivery
2	Components belonging to Case 2 (*):	(1)	Conformity with the order	Testing is not required	Each delivery
	▪ Characteristics declared in DoP for the specific use within the kit.	(2)	Acc. to Control Plan	Testing is not required	Each delivery
	▪ Characteristics not declared in DoP for the specific use within the kit.	(3)	Acc. to Control Plan	Acc. to Control Plan	Acc. to Control Plan
3	Components belonging to Case 3 (*):	(1)	Conformity with the order	Testing is not required	Each delivery
		(4)	Acc. to Control Plan	Acc. to Control Plan	Acc. to Control Plan
<p>(1) Checking of delivery ticket and/or label on the package. (2) Checking of technical data sheet and DoP or, when relevant: supplier certificates or supplier tests (3) Supplier certificates or supplier tests (4) Checking of the documentation accompanying the construction product. The documentation shall at least include: - Name and address of the manufacturer and supplier where relevant - Identification of the construction product - Description of the technical specification that was used by the manufacturer - The performances of the construction product - The test method used - The identification of the third-party body/bodies involved and the tasks this/these body/bodies performed - Date and signature</p> <p>(*) Case 1: Component covered by a hEN or its own ETA for all characteristics needed for the specific use within the kit. (*) Case 2: If the component is a product covered by a hEN or its own ETA which, however, does not include all characteristics needed for the specific use within the kit or the characteristic is presented as NPD option for the component manufacturer. (*) Case 3: The component is a product not (yet) covered by a hEN or its own ETA or is a product not CE marked in accordance to a hEN or its own ETA.</p>					

3.3 Tasks of the notified body

The cornerstones of the actions to be undertaken by the notified body in the procedure of assessment and verification of constancy of performance for the timber building kits are laid down in Table 3.

Table 3 Control plan for the notified body; cornerstones *

No	Subject/type of control	Test control method	or Criteria, if any	Minimum number of samples	Minimum frequency of control
Initial inspection of the manufacturing plant and of factory production control					
1	<p>The notified body shall verify ability of the manufacturer for a continuous and orderly manufacturing of the product. In particular, the following items shall be appropriately considered</p> <ul style="list-style-type: none"> - personnel and equipment - the suitability of the factory production control established by the manufacturer - The control of complete kits 	As defined in the control plan	As defined in the control plan	N/A**	N/A**
Continuous surveillance, assessment and evaluation of factory production control					
1	<p>The notify body shall verify</p> <ul style="list-style-type: none"> - the manufacturing processes - the system of factory production control" - the complete kit controls are maintained 	As defined in the control plan	As defined in the control plan	N/A**	2 / year***

* Control plan shall be defined in detail for each individual ETA.

** N/A=not applicable

*** If two consecutive surveillances show no (substantial) nonconformity the frequency of surveillances can be reduced to 1 per year while the frequency 2 per year is renewed when substantial nonconformity was revealed.

4 REFERENCE DOCUMENTS

EN 26891:1991, ISO 6891:1983 *Timber structures. Joints made with mechanical fasteners. General principles for the determination of strength and deformation characteristics*

EN 594:2011 *Timber structures - Test methods - Racking strength and stiffness of timber frame wall panels*

EN 338:2016 *Structural timber – Strength classes*

EN 14374:2004 *Timber structures. Structural laminated veneer lumber. Requirements*

EN 14081-1:2016 *Timber structures. Strength graded structural timber with rectangular cross section. General requirements*

EN 14080:2013 *Timber structures. Glued laminated timber and glued solid timber. Requirements*

EN 15497:2014 *Structural finger jointed solid timber - Performance requirements and minimum production requirements*

EN 301:2017 *Adhesives, phenolic and aminoplastic, for load-bearing timber structures. Classification and performance requirements*

EN 15425:2017 *Adhesives. One component polyurethane (PUR) for load-bearing timber structures. Classification and performance requirements*

EN 1991-1-2:2002 *Eurocode 1. Actions on structures. General actions. Actions on structures exposed to fire*

EN 1995-1-1:2004+A1:2008 *Eurocode 5 - Design of timber structures - Part 1-1: General - Common rules and rules for buildings*

EN 1995-1-2:2004 *Eurocode 5: Design of timber structures - Part 1-2: General - Structural fire design*

EN 1998-1:2004 *Eurocode 8 - Design of structures for earthquake resistance - Part 1: General rules, seismic actions and rules for buildings*

EN 10346:2015 *Continuously hot-dip coated steel flat products for cold forming - Technical delivery conditions*

EN ISO 1460:1994 *Metallic coatings - Hot dip galvanized coatings on ferrous materials - Gravimetric determination of the mass per unit area*

EN ISO 1461:2009 *Hot dip galvanized coatings on fabricated iron and steel articles - Specifications and test methods*

EN ISO 2178:2016 *Non-magnetic coatings on magnetic substrates - Measurement of coating thickness - Magnetic method*

EN ISO 2081:2018 *Metallic and other inorganic coatings - Electroplated coatings of zinc with supplementary treatments on iron or steel (ISO 2081:2018)*

EN ISO 2177:2004 *Metallic coatings - Measurement of coating thickness - Coulometric method by anodic dissolution (ISO 2177:2003)*

EN 10088-1:2014 *Stainless steels - Part 1: List of stainless steels*

EN 13501-1:2018 *Fire classification of construction products and building elements – Part 1: Classification using data from reaction to fire tests*

EN 13501-2:2016 *Fire classification of construction products and building elements – Part 2: Classification using data from fire resistance tests, excluding ventilation systems*

EN 13501-5:2016 *Fire classification of construction products and building elements - Part 5: Classification using data from external fire exposure to roofs tests*

EN 13823:2010 *Reaction to fire tests for building products. Building products excluding floorings exposed to the thermal attack by a single burning item*

EOTA Technical Report TR 034 General BWR 3 Checklist for EADs/ETA - *Content and/or release of dangerous substances in construction products*

EN 16516:2017 *Construction products: Assessment of release of dangerous substances. Determination of emissions into indoor air*

EN ISO 10456:2007 *Building materials and products – Hygrothermal properties – Tabulated design values and procedures for determining declared and design thermal values*

EN ISO 12572:2017 *Hygrothermal performance of building materials and products – Determination of water vapour transmission properties. Cup method*

EN ISO 13788:2012 *Hygrothermal performance of building components and building elements – Internal surface temperatures to avoid critical surface humidity and interstitial condensation - Calculation methods*

EN 12865:2001 *Hygrothermal performance of building components and building elements – Determination of the resistance of external wall systems to driving rain under pulsating air pressure*

EN 1027:2016 *Windows and doors. Watertightness. Test method*

EN 12208:1999 *Windows and doors - Watertightness - Classification*

EAD 030352-00-0503 *Watertight covering kits for wet room floors and or walls*

EN 1195:1997 *Timber structures - Test methods - Performance of structural floor decking*

EOTA Technical Report TR 001 *Determination of impact resistance of panels and panels assemblies*

EAD 210005-00-0505 *Internal partition kits for use as non-loadbearing walls*

EN ISO 16283-1:2014 *Acoustics. Field measurement of sound insulation in buildings and of building elements. Airborne sound insulation*

EN ISO 16283-2:2018 *Acoustics. Field measurement of sound insulation in buildings and of building elements. Impact sound insulation*

EN ISO 717-1:2013 *Acoustics - Rating of sound insulation in buildings and of building elements - Part 1: Airborne sound insulation; Amendment 1: Rounding rules related to single number ratings and single number quantities*

EN ISO 717-2:2013 *Acoustics - Rating of sound insulation in buildings and of building elements - Part 2: Impact sound insulation; Amendment 1*

ISO 11654:1997 *Acoustics. Sound absorbers for use in buildings. Rating of sound absorption*

EN ISO 6946:2017 *Building components and building elements - Thermal resistance and thermal transmittance - Calculation methods*

EN ISO 354:2010 *Acoustics. Measurement of sound absorption in a reverberation room*

EN ISO 10140-1:2016 *Acoustics – Laboratory measurement of sound insulation of building elements - Part 1: Application rules for specific products*

EN ISO 10140-2:2010 *Acoustics – Laboratory measurement of sound insulation of building elements - Part 2: Measurement of airborne sound insulation*

EN ISO 10140-3:2010 *Acoustics – Laboratory measurement of sound insulation of building elements - Part 3 Measurement of impact sound insulation*

EN ISO 10140-4:2010 *Acoustics – Laboratory measurement of sound insulation of building elements - Part 4: Measurement procedures and requirements*

EN ISO 10140-5:2010 *Acoustics – Laboratory measurement of sound insulation of building elements - Part 5: Requirements for test facilities and equipment*

EN 12354-1:2017 *Building acoustics - Estimation of acoustic performance of buildings from the performance of elements - Part 1: Airborne sound insulation between rooms*

EN 12354-2:2017 *Building acoustics - Estimation of acoustic performance of buildings from the performance of elements - Part 2: Impact sound insulation between rooms*

EN 12354-3:2017 *Building acoustics - Estimation of acoustic performance of buildings from the performance of elements - Part 3: Airborne sound insulation against outdoor sound*

EN 12354-4:2017 *Building acoustics. Estimation of acoustic performance of buildings from the performance of elements. Transmission of indoor sound to the outside*

EN ISO 6946:2017 *Building components and building elements - Thermal resistance and thermal transmittance- Calculation method*

EN 14351-1:2006 *Windows and doors. Product standard, performance characteristics. Windows and external pedestrian doorsets*

EN ISO 8990:1996 *Thermal insulation – Determination of steady-state thermal transmission properties – Calibrated and guarded hot box*

EN ISO 10211:2017 *Thermal bridges in building construction - Heat flows and surface temperatures - Detailed calculations*

EN 1026:2016 *Windows and doors - Air permeability - Test method*

EN 12207:2016 *Windows and doors - Air permeability - Classification*

EN ISO 9972:2015 *Thermal performance of buildings - Determination of air permeability of buildings - Fan pressurization method*

EN 12114:2000 *Thermal performance of buildings - Air permeability of building components and building elements – Laboratory test method*

EN ISO 13786:2017 *Thermal performance of building components. Dynamic thermal characteristics. Calculation methods*

EN 13183-2:2002 *Moisture content of a piece of sawn timber. Estimation by electrical resistance method*

Kaufmann, H.; Krötsch, S.; Winter S.; et al. (2018): Manual of Multi-Storey Timber Construction. published DETAIL Business Information GmbH. Munich. ISBN Print 978-3-95553-394-6

Schober, P.; Koch, C.; et al. (2018). Fassaden aus Holz. 3. revised edition. published proHolz Austria. Vienna. ISBN 978-3-902320-74-2

Kolb, J. (2008): Systems in Timber Engineering. published Birkhäuser. Berlin. ISBN-13: 9783764386900

Knut Ivar Edvardsen og Trond Ramstad SINTEF Byggforsk. (2014): Trehus håndbok 5. Oslo. ISBN 978-82-536-1391-8

www.dataholz.eu - *Catalogue of wood and wood-based materials, building materials, components and component connections for timber construction covering thermal, acoustic, fire and ecological performance levels, released by accredited testing institutes., 2019-*

ANNEX A – DESCRIPTION OF THE KIT

The general design of timber kit main building elements and section build up with individual material and component specifications shall be specified in ETA. The description of timber kits may be presented in ETA as shown in Figures A.1- A.3. and Tables A.1. In addition to material and component specification, the timber building kits may be described by relevant drawings of the kit build-up and construction details, as shown in table A.2.

Element	Type: external wall
----------------	----------------------------

design drawing

Construction: (from outside to inside)				
	Component	Type	Dimension [mm]	Distance [mm]
A	Wood cladding (closed)		≥ 20	
B	Timber battens (ventilated)		30	
C	MDF (medium density fibre board)		15	
D	Construction timber	C24	≥60/160	625
E	Mineral wool	A1; 0,035	160	
F	OSB (used also as vapour barrier)	OSB 3; $s_d \geq 2m$		
G	Timber battens (cross battens)		40/60	625
H	Mineral wool	A1; 0,035	40	
I	Gypsum plaster board	DF	12,5	

Fasteners:			
Component	Type	Dimension [mm]	Distance [mm]
OSB/MDF	Staples	1,5/50	100
Gypsum plaster board	Screw	3,9x35	250

Figure A.1: Example of an external wall element with used components

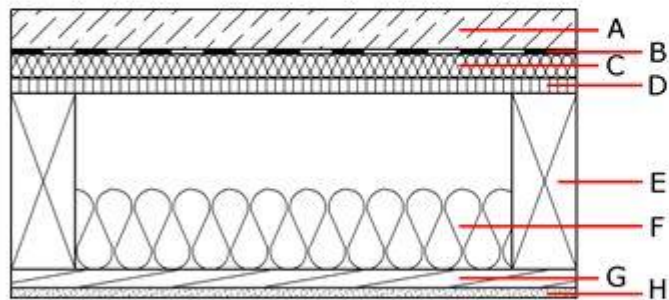
Element**Type: ceiling/floor****design drawing****Construction: (top down)**

	Component	Type	Dimension [mm]	Distance [mm]
A	Screed		≥ 50	
B	Separation foil layer			
C	Acoustic insulation MW-T		30	
D	OSB	OSB3	18	
E	Construction timber	C24	80/220	625
F	Mineral wool	A2; 0,040	100	
G	Timber battens (cross battens)		27	400
H	Gypsum plaster board	DF	12,5	

Fasteners:

Component	Type	Dimension [mm]	Distance [mm]
OSB	Staples	1,5/63	100
Gypsum plaster board	Screw	3,9x35	170

Figure A.2: Example of a floor element with used components

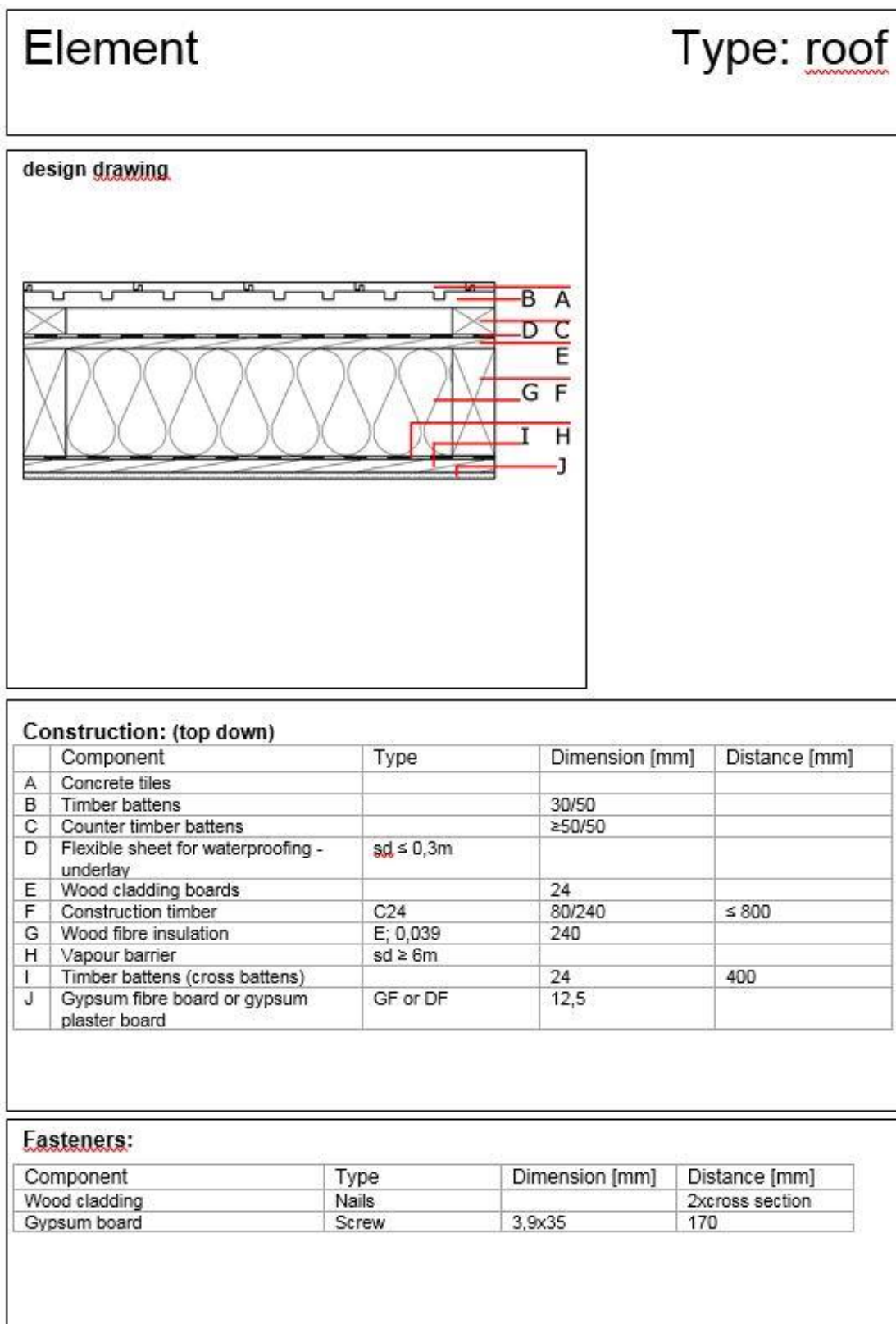

Figure A.3: Example of a roof element with used components

Table A.1. shows how materials and components of a kit may be specified. The list contains only examples and is not a complete list of all relevant materials and components in a timber building kit.

Table A.1. Example of a specification list in an ETA for the materials and components of the timber building kits

Product ¹⁾	Standard	ρ [kg/m ³]	λ [W/mK]	μ	c [kJ/kgK]	Euroclass	
Strength graded structural timber	DIN 4074-1/ EN 14081 EN 338	450	0,12	50	1,6	D-s2,d0	EN 14081 2003/43/EC
Finger jointed solid structural timber	EN 15497	450	0,12	50	1,6	D-s2,d0	EN 15497 2003/43/EC
Wood cladding	EN 14915	450	0,12	50	1,6	D-s2,d0	EN 14915 2006/213/EC
Glued laminated timber	EN 14080	450	0,12	50	1,6	D-s2,d0	EN 14080
Cross laminated timber	ETA	450	0,12	50	1,6	D-s2,d0	ETA based on EAD
Particleboard	EN 13986 EN 312	700	0,13	50/100	1,7	D-s2,d0	EN 13986 2003/43/EC
OSB	EN 13986 EN 300	≥ 600	0,13	200	1,7	D-s2,d0	EN 13986 2003/43/EC
Solid wood board	EN 13986 EN 13353	500	0,13	50	1,7	D-s2, d0	EN 13986 2003/43/EC
Gypsum board	EN 520	800	0,25	10	1,05	A2-s1,d0 B-s1,d0	EN 520 2003/43/EC
Gypsum fibre board	ETA EN 15283-2	1000	0,32	21	1,1	A2-s1,d0	ETA EN 15283-2
Mineral wool MW/ MW-T/ MW-PT	EN 13162	18-110	0,035-0,040	1	1,03	A1-A2	96/603/EC
Wood fibre Insulation WF	EN 13171	45-190	0,042-0,046	5-7	2,1	E	EN 13171
Polystyrene EPS/ EPS-F	EN 13163	15-20	0,031-0,040	30-60	1,45	E	EN 13163
Extruded polystyrene XPS	EN 13164	20-25	0,032-0,035	30-70	1,45	E	EN 13164
Vapour barrier	EN ISO 12572 EN 13984	-	-	sd \geq 10m	-	-	no performance assessed
Breather membrane/ Flexible sheet – underlays	EN ISO 12572 EN 13859-1 EN 13859-2	-	-	sd \leq 0,3m	-	-	no performance assessed

Product ¹⁾	Standard	ρ [kg/m ³]	λ [W/mK]	μ	c [kJ/kgK]	Euroclass	
Flexible sheet for waterproofing	EN 13956	-	-	sd \geq 40m	-	-	no performance assessed
Fasteners	EN 14592	-	-	-	-	-	no performance assessed
Concrete roofing tile	EN 490	2100	1,5	60/100	1	A1	96/603/EC
						B _{ROOF}	2000/553/EC
Clay roofing tile	EN 1304	2000	1,0	30/40	0,8	A1	96/603/EC
						B _{ROOF}	2000/553/EC
Metal sheet roofing	EN 501	-	-	-	-	A1	96/603/EC
						B _{ROOF}	2000/553/EC
Gravel	-	-	-	-	-	A1	96/603/EC
						B _{ROOF}	2000/553/EC
Window and external door	EN 14351-1	$U_w \leq 1,4$ [W/m ² K]		$R_w \geq 35$ (-2;-6)		-	
ETICS-EPS	ETA	Impact resistance: mind. Kat. II				B-s2,d0 (system) E (EPS)	ETA based on EAD
ETICS-MW	ETA	Impact resistance: mind. Kat. II				A2-s1,d0 (system) A2 (MW)	ETA based on EAD
ETICS- WF	ETA	Impact resistance: mind. Kat. II				B-s1,d0 (system) E (WF)	ETA based on EAD

- 1) Products which are not covered by a harmonised European standard or an ETA, shall be specified by their brand name and type, or by another description which ensure the properties that has been assumed when assessing the characteristic of the kit.

Table A.2. is giving the examples of relevant drawings of the kit build-up and construction details which may be used for description of timber building kits.

Table A.2. The list of relevant drawings of the kit build-up and construction details

The list of relevant drawings of the kit build-up and construction details	
External walls	
1	Vertical and horizontal section of principal standard wall design
2	Elevation of standard structural system
3	Principal design of structural supplements around door and windows openings (beams and sidestuds)
4	Installation of windows and doors – Section of joints between wall and bottom, side and top frame members
5	Horizontal section of standard corner joints
5	System for wall ties and uplift anchors
6	Horizontal cross-section of joints between prefabricated elements or components including corner joints
Internal walls	
1	Vertical and horizontal section of principal standard wall design
2	Elevation of standard structural system
3	Principal design of structural supplements around door openings (beams and sidestuds)
4	Horizontal section of standard corner joints
5	Vertical and horizontal section of principal standard separating wall design
6	Elevation of standard structural system for principal standard separating wall design
Floors	
1	Vertical section of standard floor design over foundations
2	Vertical section of standard floor design
3	Plan of standard structural floor system
4	Structural design for floor openings
Roof	
1	Vertical section of standard roof design
2	Plan of standard structural roof design
3	Vertical section of standard roof design with integrated external roofing
4	Vertical section of standard roof design with external roof installed on site
Connections between module parts	
1	Vertical cross-section of shaft walls

The list of relevant drawings of the kit build-up and construction details	
2	Horizontal cross-section of shaft walls
3	Principle design of fire stops between separate fire compartment
Connections between unite parts	
1	Vertical section of joints between floor and external wall
2	Vertical section of joints between floor and internal walls
3	Vertical section of joints between walls and roof
Wet-rooms	
1	Vertical and horizontal section of principal standard wall design
2	Elevation of standard structural wall design
3	Vertical section of standard floor design, including slope towards floor gutter
4	Horizontal section of wall corner joints
5	Vertical section of joints between floor and walls
6	Vertical section of floor at door opening
7	Vertical section of connection between wall and roof/ceiling
8	Section of floor gutter installation and pipe penetrations
9	Principle design of pipe installations
Shafts for technical services	
Drawings of shaft walls and sealing system around pipes and ducts in shafts for technical service installations	
Connections between kits	
1	Section of principle standard connection between kit and foundation
2	Section of standard connection between kits at external walls
3	Section of standard connection between kits at internal walls
4	Section of standard connection between kits at floors
5	Section of standard connection between kits at dwelling separation walls
6	Section of standard connection between kits at dwelling separation walls and dwelling separating floors
7	Section of standard connection between kits at external roof

ANNEX B - WATERTIGHTNESS OF LOG WALLS APPLYING THE TESTING STANDARD EN 1027

Watertightness of log walls shall be assessed by applying the testing standard EN1027.

Air pressure and water spraying of the test setup are specified in the standard.

Test setup and test specimen

Straight wall specimen and corner specimen shall be tested, see figures B.1 to B.3.

Test specimen size shall be:

- Height 800 - 1000mm including 3 - 4 joints between layers of logs
- Length ~1200mm

Dowelling system of the product shall be specified for the test. Threaded bars may be used for tightening the log joints in the test. Their nuts should be tightened to 50 Nm moment. Straight wall specimens need to be sealed in the ends of the logs and on the top of the dowelling holes. Corner specimen needs sealed panels on the top and bottom to make the structure tight in the test up.

First water is sprayed on the specimen for 15 min. After that in addition to the water spraying, air pressure is increased from 0 Pa to 750 Pa in steps of 50, 100, 150, 200, 250, 300, 450, 600, 750. After that, the pressure is increased in step of 150 Pa, if in exceptional cases the airflow is measured in a higher pressure than 750 Pa. Each step takes at least 5 min to achieve the specified air pressure.

Expression of the results:

Pressure levels when water leakages start, and locations of the leakages are recorded, see figure B.4.

After the test the specimen structure shall be dismantled and wet areas of the top and bottom surfaces of the logs are marked, see figure B.4. In case of water absorbing sealant material, the amount of water is measured by weighting before and after the test.

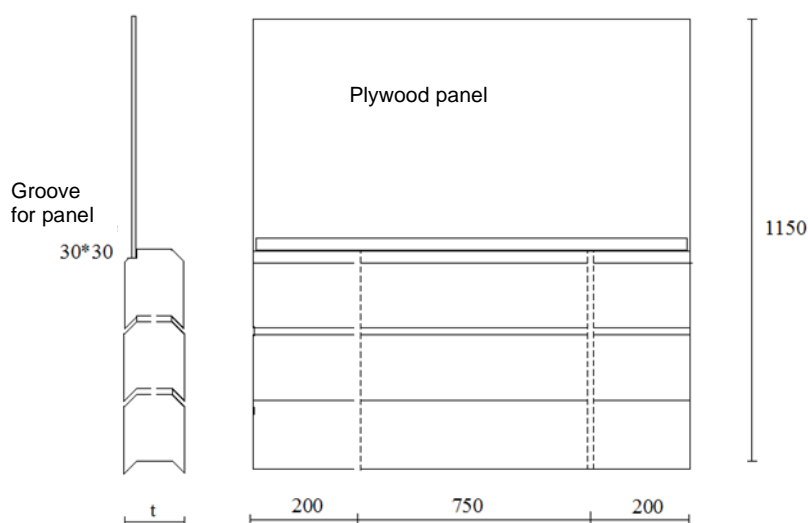

Figure B.1: Log house straight wall specimen for airtightness and watertightness test setup

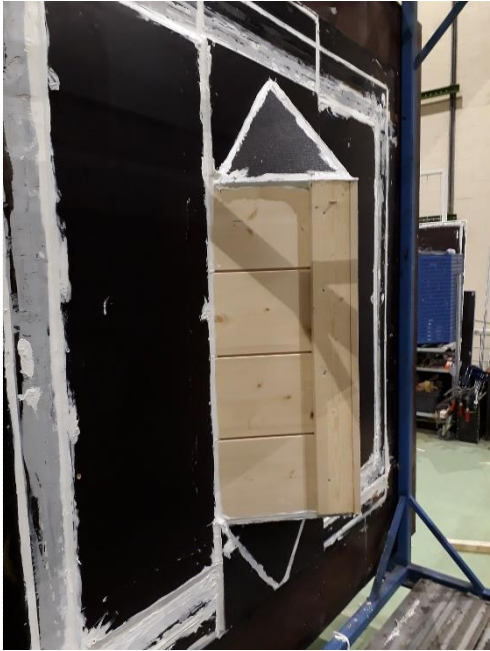
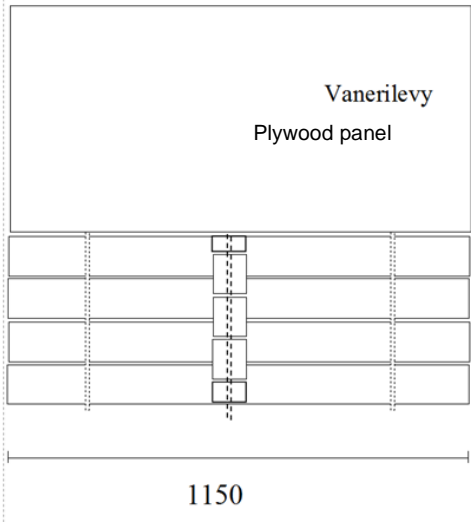

Figure B.2: Log house specimen with a joint between exterior and interior walls for airtightness and watertightness test setup

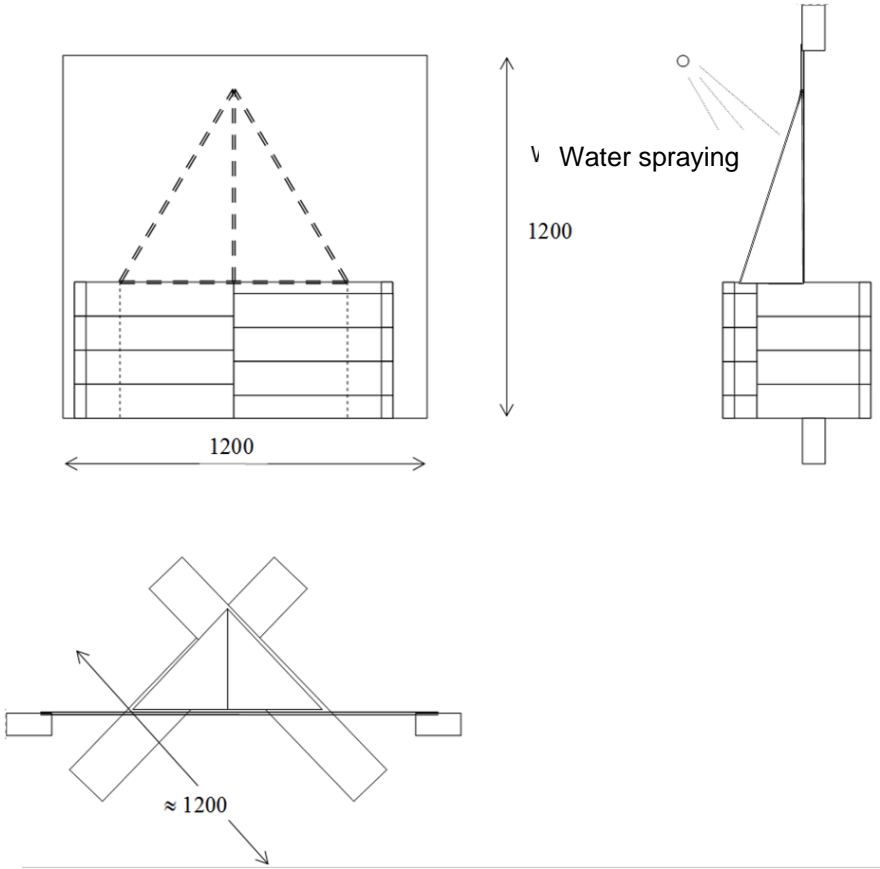

Figure B.3: Log house corner specimen in watertightness test setup



Figure B.4: Left: Marking of water leakage points and the time and pressure when the leakage has started in watertightness test. Right: Example of marking the wet areas to logs after dismounting of the specimen in watertightness test.

ANNEX C DETERMINATION OF IMPACT RESISTANCE OF PANELS AND PANEL ASSEMBLIES

C.1 Scope

This annex specifies test methods for impact resistance of panel and panel assemblies.

C.2 Test method for determining soft body impact resistance

C.2.1 Principle

The soft body impact test simulates an impact resulting from a person accidentally falling against the panel.

The soft body is dropped from a height, creating an impact energy, which corresponds with the impact energy released by a person.

The test is conducted with reference to safety in use, i.e. verification whether the panel or panel assemblies would prevent a person falling through, and to serviceability, i.e. verification whether they would still perform as intended.

C.2.2 Test apparatus

The soft body impactor should be a spherical canvas bag of diameter 400 mm (± 40) (see Figure C.1) filled with 3.0 mm (± 0.3) diameter glass spheres to give a total weight of 50 kg (± 0.5).

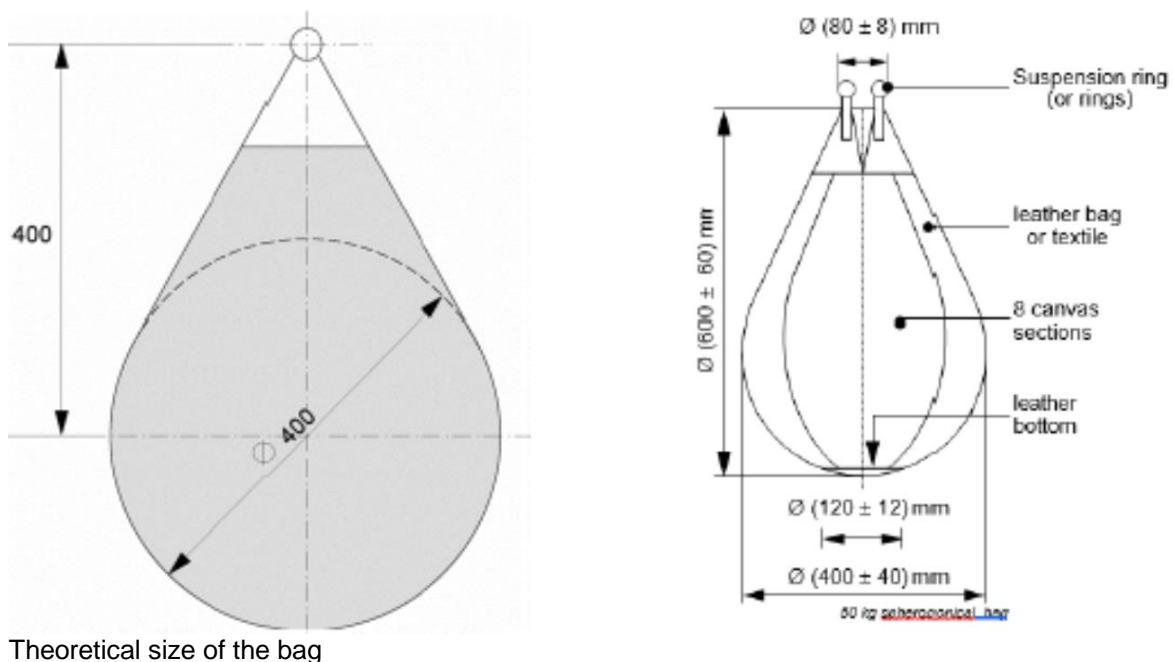

Figure C.1 – Soft body impactor

C.2.3 Number of tests

C.2.3.1 Serviceability impact resistance

The test shall be carried out on one test assembly, and generally consists of at least three impacts with the same energy at about the same point of impact. The point of impact should be the one deemed most onerous for the assembly under examination.

If various impact energies are being tested, new assemblies should be tested for each impact energy.

C.2.3.2 Safety in use impact resistance

The test shall be carried out on one test assembly and consists of one impact.

The point of impact should be the one deemed most onerous for the assembly under examination.

If various impact energies are being tested, new assemblies should be tested for each level of impact energy.

Note - The serviceability and safety in use impact tests should not be carried out on the same assembly, unless the ETA-applicant of the test so wishes.

C.2.4 Conditioning and test conditions

The panel conditioning shall be recorded, where required.

The conditioning period, if any, shall be agreed with the manufacturer.

The test shall be carried out in normal laboratory circumstances.

C.2.5 Test assembly

The panels shall be mounted in accordance with the manufacturer's installation specifications, with regard to the intended use (wall or ceiling panel), so that the test assembly corresponds as much as possible with end use conditions.

The manner in which components are fixed to each other shall reproduce actual conditions of use, particularly with respect to the nature, type and position of the fixings and the distance between them.

If the manufacturer's specifications foresee more than one possible end-use assembly, the test shall be performed at least on the most onerous one.

The manufacturer has the possibility to test additional assemblies, if he claims better performance.

In principle, the most onerous assembly shall be:

- panel: the panel with the highest ratio length (or height) over width in its minimum thickness;
- span: maximum distance between supports.

C.2.6 Test procedure

In this test, the soft body impactor, with mass (m) is dropped from a height (h), so that the total impact energy ($E = g \times h \times m$) corresponds with one of the following energies E in Nm: 60, 100, 120, 130, 200, 240, 300, 400, 500, 600, 700, 900 and 1200.

Note - In most cases $g = 9,81$ m/s

The height (h) is measured between the designated point of impact and the height of release of the soft body impactor.

For tests conducted on wall assemblies the angle α shall always be smaller or equal to 65° (see Figure C.2).

The bag is held vertically when released (not horizontally).

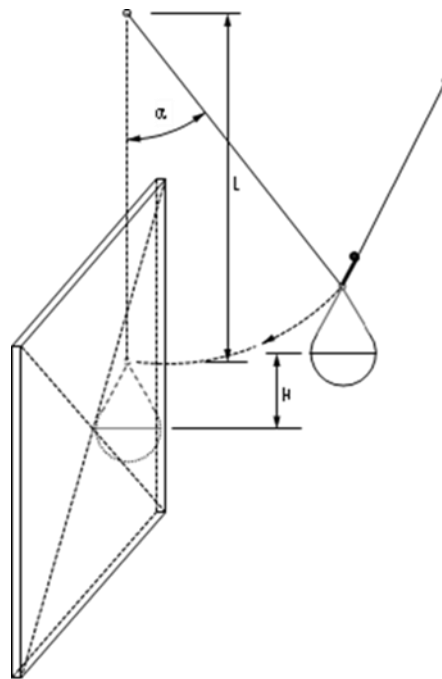

Figure C.1 – Impact on vertical assembly h = drop height; L = length rope; $\alpha = 65^\circ$

For ceiling assemblies, the test is performed on a horizontal assembly (see Figure C.3).

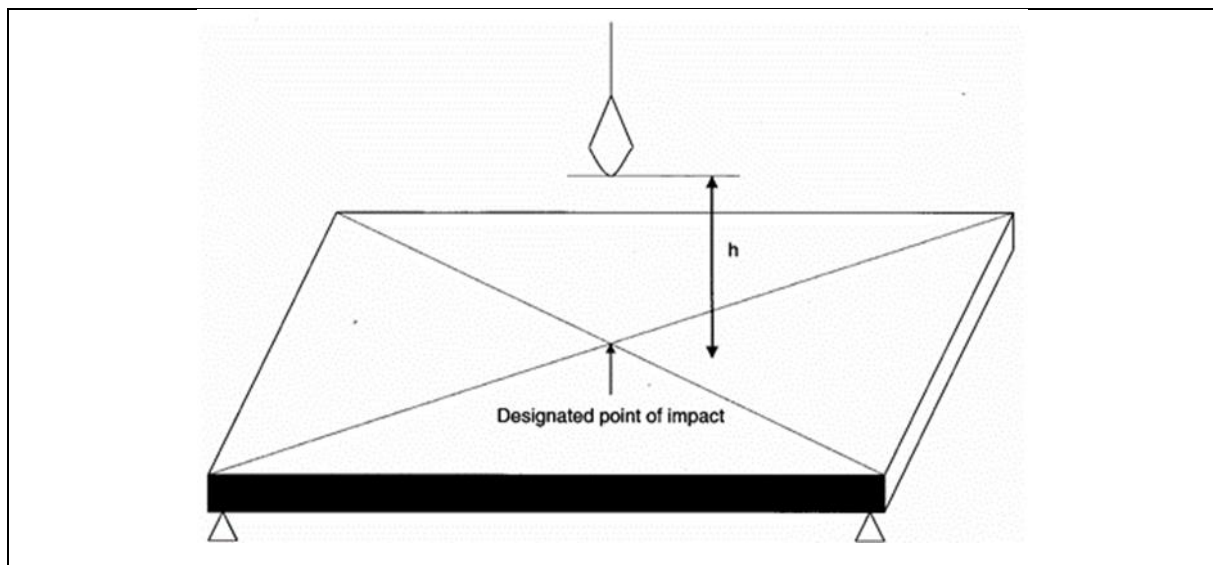

Figure C.2 – Vertical impact on horizontal assembly h = drop height

C.2.7 Expression of test results

The test result is pass/fail, depending on whether the panel assemblies meet the following combined criteria:

For safety in use:

- no collapse: the test result is favorable when, after the test, the panel or assembly maintains its mechanical integrity and is still capable of carrying its own weight in the tested position;

no penetration: the test result is favorable when, after the test, the impactor has not passed through the test specimen;

- no projection: the test result is favorable when, after the test, the impactor has not created parts of the panel (e.g. core, face, reinforcement) to project from the face of the panel, on the other side of the specimen than the impact side, creating sharp cutting edges or surfaces likely to cause personal injury by contact.

For serviceability:

- no penetration: the test result is favorable when, after the test, the impactor has not penetrated the face of the test specimen on the impact side of the specimen.

- no degradation: the test result is favorable when, after the test, there are no visible (to the naked eye) cracks, depressions, protuberances or any other defects in the materials, which may influence the fitness for use of the panel or assembly. Deformations, which only affect the appearance, are allowed, but should be mentioned in the test report.

In a favorable test result, the report shall indicate any damage (e.g. localized surface cavities of small dimensions, scratches, wear marks in the form of grooves, etc.).

For extended application of the test results, the general rule is that test results for the most onerous assembly can be used to reflect the behavior of others.

C.2.8 Test report

The test report shall include:

- reference to clause 2 of this annex;
- the name of the testing laboratory;
- the name of the ETA applicant (and manufacturer of the panel);
- date of the test;
- description of the test instruments;
- identification of the product tested (designation, dimensions and any relevant identification characteristic);
- surface structure (e.g. smooth, profiled, structured);
- description of the sample tested, and reference to its marking;
- description of conditioning and preparation of the sample (if any);
- description of test conditions (temperature and RH), where required;
- results of the test, including a description of safety (if any).

C.3 Test methods for determining hard body impact resistance

C.3.1 Principle

The hard body impact test simulates the impact, resulting from an object accidentally falling against the panel.

The hard body is dropped from a height, creating an impact energy, which corresponds with the impact energy released when furniture or similar objects with the panel.

The test is conducted with reference to safety in use, i.e. assessment whether the panel or panel assemblies would prevent an object falling through, and to serviceability, i.e. verification whether they would still perform as intended (e.g. with reference to water vapour tightness).

C.3.2 Test apparatus

For safety in use, the hard body impactor should be a steel ball, with a diameter of 63.5 mm (± 1), with a mass of 1030 g (± 40) (1 kg steel ball).

For serviceability, it should be a steel ball, with a diameter of 50 mm (± 0.5), with a mass of 514 g (± 19) (0.5 kg steel ball).

C.3.3 Number of tests

C.3.3.1 Serviceability impact resistance

The test shall be carried out on one test panel, and generally consists of at least three impacts at approximately the same point of impact.

The point of impact should be the one deemed most onerous for the assembly under examination.

C.3.3.2 Safety in use impact resistance

The test shall be carried out on one test panel and consists of one impact.

The point of impact should be the one deemed most onerous for the assembly under examination.

Note - The serviceability and safety in use impact test should not be carried out on the same panel, unless the ETA-applicant of the test so wishes.

C.3.4 Conditioning and test conditions

The panel conditioning shall be recorded, where required. The conditioning period, if any, shall be agreed between the ETA applicant.

The test shall be carried out in normal laboratory circumstances.

C.3.5 Test assembly

The panel shall be horizontally positioned on supports (see Figure C.4), to allow, in case of an unfavorable test result, the possibility of the impactor going completely through the panel.

The most onerous point of impact should be chosen.

In most cases this will be the center of the panel, but, for panels with reinforcement (studs, stiffening ribs, etc.) behind a relatively weak face, the most onerous impact position is 25 mm (± 2) from the edge of the reinforcement.

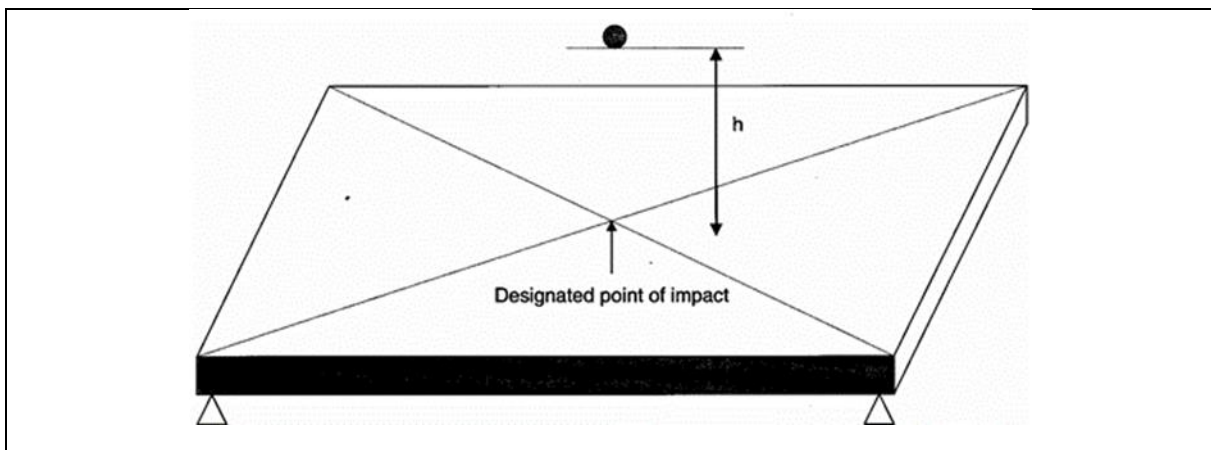

Figure C.4– Assembly for hard body impact test

C.3.6 Test procedure

In this test, the hard body impactor with mass (m) is dropped from a height (h), so that the total impact energy ($E = g \times h \times m$) corresponds with one of:

- hard body impact test (1 kg steel ball): 3 Nm or 10 Nm;
- hard body impact test (0.5 kg steel ball): 1.3 Nm; 2.5 Nm; 3.75 Nm or 6 Nm.

Note - In most cases $g = 9,81$ m/s.

The height (h) is measured between the designated point of impact and the height of release of the hard body impactor.

C.3.7 Expression of test results

The test result is pass/fail, depending on whether the panel assemblies meet the following combined criteria:

Safety in use:

- no collapse: the test result is favorable when, after the test, the panel or assembly maintains its mechanical integrity and is still capable of carrying its own weight in the tested position;
- no penetration: the test result is favorable when, after the test, the impactor has not passed the test specimen;
- no projection: the test result is favorable when, after the test, the impactor has not created parts of the panel (e.g. core, face, reinforcement) to project from the face of the panel, on the other side of the specimen than the impact side, creating sharp cutting edges or surfaces likely to cause injury by contact.

Serviceability:

- no penetration: the test result is favorable when, after the test, the impactor has not penetrated the face of the test specimen on the impact side of the specimen;
- no degradation: the test result is favorable when, after the test, there are no visible (to the naked eye) cracks, depressions, protuberances or any other defects in the materials, which may influence the fitness for use of the panel or assembly. Deformations, which only affect the appearance, are allowed, but should be mentioned in the test report.

In a favorable test result, the report shall indicate any damage (e.g. localized surface cavities of small dimensions, scratches, wear marks in the form of grooves, etc.).

For extended application of the test results, the general rule is that test results for the most onerous assembly can be used to reflect the behavior of others.

Note: A list of products that are "deemed-to-satisfy without the need for testing" shall be established in an accompanying comprehension document.

C.3.8 Test report

The test report shall include:

- reference to the clause 3 of this Annex;
- the name of the testing laboratory;
- the name of the ETA Applicant (and manufacturer of the panel);
- date of the test;
- description of the test instruments;
- identification of the product tested (designation, dimensions and any relevant identification characteristic);
- surface structure (e.g. smooth, profiled, structured,...);
- description of the sample tested, and reference to its marking;
- description of conditioning and preparation of the sample (if any);
- description of test conditions (temperature and RH), where required;
- results of the test, including a description of safety (if any).

C.4 Recommendation of use of this annex

This Annex provides information regarding the known energy levels used for impact resistance tests in EEA countries, at the time of writing.

In some cases, several energy levels have been identified, depending on the regulatory requirements in different countries.

Internal walls

Safety in use

Test	Impactor (kg)	No. of impacts	Energy (J)	Criteria
Soft body impact	50	1	100 - 200 - 300 - 400 or 500	no collapse and no penetration and no projection
Hard body impact	1	1	10	

Note - For soft body impact, depending on the use of the space the product encloses, the following types may be foreseen:

Type I: Zones accessible primarily to those with high incentive to exercise care. Small risk of accidents occurring and of misuse (100 J).

Type II: Zones accessible primarily to those with some incentive to exercise care. Some risk of accidents occurring and of misuse (200 J).

Type III: Zones readily accessible to public and others with little incentive to exercise care. Risk of accidents occurring and of misuse (300 J).

Type IV: Zones and risk as II and III. In case of failure, risk includes the fall to a floor at a lower level (400 J or 500 J, depending on regulatory requirements)

Serviceability

Test	Impactor (kg)	No. of impacts	Energy (J)	Criteria
Soft body impact	50	3	60 or 120	no penetration and no projection
Hard body impact	0.5	3	2,5 * or 6 **	

Note:

* Zones I and II as indicated in the note above

** Zones III and IV as indicated in the note above.

External walls

Safety in use

Test	Impactor (kg)	No. of impacts	Energy (J)	Criteria
Soft body impact	50	1	700 or 900	no collapse and no penetration and no projection
Hard body impact	1	1	10	

Serviceability

Test	Impactor (kg)	No. of impacts	Energy (J)	Criteria
Soft body impact	50	3	100 – 130 – 300 or 400	no penetration and no degradation
Hard body impact	0.5	3	2,5 * or 6 **	

Roofs / Ceilings

Safety in use

Test	Impactor (kg)	No. of impacts	Energy (J)	Criteria
Soft body impact	50	1	900 or 1200	no collapse and no penetration and no projection
Hard body impact	1	1	10	

Serviceability

Test	Impactor (kg)	No. of impacts	Energy (J)	Criteria
Soft body impact	50	1* / 5**	100 – 130 – 300 or 400	no penetration and no degradation
Hard body impact	0.5	3	5* - 10**	

* Roofs, accessible for installation and maintenance only

** Accessible roofs

Floors**Safety in use**

Test	Impactor (kg)	No. of impacts	Energy (J)	Criteria
Soft body impact	50	1	No recommendation available	no collapse and no penetration and no projection
Hard body impact	1	1		

Serviceability

Test	Impactor (kg)	No. of impacts	Energy (J)	Criteria
Soft body impact	50	3	No recommendation available	no penetration and no degradation
Hard body impact	0.5	3		