



www.eota.eu

EAD 350003-01-1109

July 2018

European Assessment Document for

Kit for fire resistant service ducts
consisting of prefabricated
connection pieces (made of steel
sheet with an intumescent coating or
lining) and accessories



The reference title and language for this EAD is English. The applicable rules of copyright refer to the document elaborated in and published by EOTA.

This European Assessment Document (EAD) has been developed taking into account up-to-date technical and scientific knowledge at the time of issue and is published in accordance with the relevant provisions of Regulation No (EU) 305/2011 as a basis for the preparation and issuing of European Technical Assessments (ETA).

Contents

1	Scope of the EAD	4
1.1	Description of the construction product	4
1.2	Information on the intended use(s) of the construction product	5
1.2.1	Intended use(s).....	5
1.2.2	Working life/Durability.....	5
1.3	Specific terms used in this EAD	6
1.3.1	Service duct.....	6
1.3.2	Duct components	6
1.3.3	Service support construction	6
1.3.4	Suspension devices of the service duct	6
1.3.5	Specific devices for inlet and outlet of cables or pipes	6
2	Essential characteristics and relevant assessment methods and criteria	7
2.1	Essential characteristics of the product	7
2.2	Methods and criteria for assessing the performance of the kit for fire-resistant service ducts in relation to essential characteristics of the product	8
2.2.1	Reaction to fire of the kit components	8
2.2.2	Propensity to undergo continuous smouldering	9
2.2.3	Resistance to fire of the service duct	9
2.2.4	Durability of the resistance to fire of the service duct.....	10
2.2.4.1	Fire protective performance	10
2.2.4.2	Resistance to the effects of higher temperatures	10
2.2.4.3	Resistance to the effects of direct contact with metals and plastics	10
2.2.4.4	Adhesion between the reactive component and the substrate	11
2.2.4.5	Resistance to the effects of constant low temperatures (permanent frost)	11
2.2.4.6	Heat insulation efficiency (ablative component).....	11
2.2.5	Content, emission and/or release of dangerous substances of the kit components.....	11
3	Assessment and verification of constancy of performance	13
3.1	System(s) of assessment and verification of constancy of performance	13
3.2	Tasks of the manufacturer	14
3.3	Tasks of the notified body	15
4	Reference documents	17
Annex A	Resistance to fire- field of direct application of test results	18
Annex B	Propensity to undergo continuous smouldering	19
Annex C	Reaction to fire – requirements for small components	20
Annex D	Assessment of the reactive components.....	21
Annex E	Durability of the intumescent components	28

1 SCOPE OF THE EAD

1.1 Description of the construction product

This EAD applies to kits for fire-resistant service ducts consisting of pre-fabricated connection pieces (made of steel sheet with an intumescent coating or lining) and accessories (in the following referred to as kits for fire-resistant service ducts). These kits consist of the following components:

- a) pre-fabricated connecting pieces - in one piece or in two pieces with a bottom part and a top part - in different dimensions, forms and designs, consisting of
 - a folded or bent steel sheet (non-corrosive stainless steel or galvanised steel),
 - a mechanically applied reactive component, which can be an intumescent one or an ablative one including pre-treatment (e.g., primer) or a lining of a self-adhesive or glued reactive material on the inside of the sheet and an optional surface coating, and
 - additional components as parts of the connecting pieces (e.g., barrier strips, cable clamps etc.);
- b) pre-fabricated special pieces (e.g., end caps, cable inlets/outlets) - in different dimensions and designs, consisting of
 - a folded or bent steel sheet (non-corrosive stainless steel or galvanised steel), and
 - filling, insulation or sealing of the openings for cable or pipe inlets / outlets made of suitable materials such as mineral wool (delivered separately and installed on site), reactive material, special boards, foams etc. (where applicable);
- c) accessories for assembling the service duct, like suspension devices made of stainless or galvanised steel (e.g., fastenings, connecting profiles, angles), sealing products, etc.

The components of each kit are manufactured and individually pre-assembled in view of the requirements of each project. The kit is assembled on site to form the fire-resistant service duct.

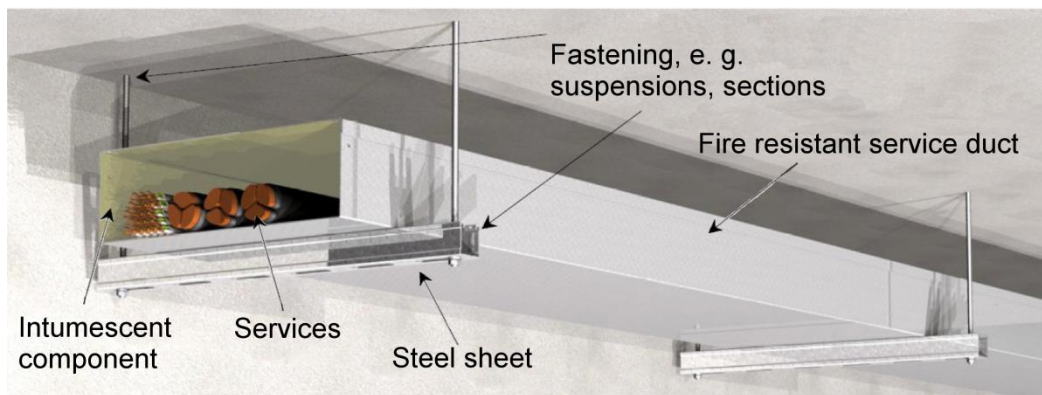

Figure 1.1.1 Example of a fire-resistant service duct

This EAD does not apply to fire-resistant service ducts with internal barriers or seals in walls. Penetration seals as components of the kits for fire-resistant service ducts are only covered by this EAD when installed at the beginning or end of the fire-resistant duct.

The product is not covered by a harmonised European standard (hEN).

This document supersedes EAD 350003-00-1109¹. In comparison to the previous version, the following has been changed:

- 1) The scope of the EAD has been enlarged with regard to the design variants of the service ducts (see lit a) to c) above).
- 2) The essential characteristics
 - Propensity to undergo continuous smouldering of kit components,

¹ All undated references to standards or to EAD's in this document are to be understood as references to the dated versions listed in chapter 4

- Fire protective performance,
 - Adhesion between the reactive component and the sheet,
 - Resistance to the effects of constant low temperatures (permanent frost), and
 - Heat insulation efficiency (ablative component)
- have been added.

3) Regarding resistance to fire, manufacturers have the choice to test service ducts with steel cables or with services (see clause 2.2.3). This is covered by the additional provisions given in Annex A which replace in so far clause 2.2.2 a) and b) of the previous version of this EAD.

4) Clause 2.2.5 related to content and/or release of dangerous substances has been amended.

Concerning product packaging, transport, storage, maintenance, replacement and repair it is the responsibility of the manufacturer to undertake the appropriate measures and to advise his clients on the transport, storage, maintenance, replacement and repair of the product as he considers necessary.

It is assumed that the product will be installed according to the manufacturer's instructions or (in absence of such instructions) according to the usual practice of the building professionals.

Relevant manufacturer's stipulations having influence on the performance of the product covered by this European Assessment Document shall be considered for the determination of the performance and detailed in the ETA.

1.2 Information on the intended use(s) of the construction product

1.2.1 Intended use(s)

The fire-resistant service duct is intended to be used for preventing the spread of fire from one fire compartment to another. The duct can be exposed to fire from outside or inside.

The duct is only intended to be used in (fastened to or passing through) building components which have the same fire resistance class as the duct.

The duct is intended to be mounted in such a way that the duct itself and the adjacent building components with a fire separating function shall remain functional throughout the required fire resistance period. This includes appropriate measures for compensating the elongation of the duct and the deflection of the building components caused by the fire.

The fire-resistant service duct is not intended to be used for

- preventing the spread of fire as a result of thermal conduction along the piping or cabling installed in service ducts, or thermal conduction through the media these pipes carry,
- preventing the spread of fire within the service duct as a result of spontaneous ignition along the cables or pipes installed in service ducts,
- maintaining the functional endurance of electrical cables,
- air distribution systems.

The fire-resistant service duct is exclusively intended for indoor application. The intended use scenarios are Type Y₂, Z₁ or Z₂ as specified in Annex E. The basic durability tests according to Annex E are necessary generally but if there are specific final use conditions expected (e.g., in chill rooms and refrigeration rooms or in other specific climates), additional tests according to Annex D shall be done.

1.2.2 Working life/Durability

The assessment methods included or referred to in this EAD have been written based on the manufacturer's request to take into account a working life of the fire-resistant service ducts assembled from the kits for the intended use of 10 years when installed in the works provided that the fire-resistant service ducts assembled from the kits are subject to appropriate installation (see 1.1). These provisions are based upon the current state of the art and the available knowledge and experience.

When assessing the product, the intended use as foreseen by the manufacturer shall be taken into account. The real working life may be, in normal use conditions, considerably longer without major degradation affecting the basic requirements for works².

The indications given as to the working life of the construction product cannot be interpreted as a guarantee neither given by the product manufacturer or his representative nor by EOTA when drafting this EAD nor by the Technical Assessment Body issuing an ETA based on this EAD, but are regarded only as a means for expressing the expected economically reasonable working life of the product.

1.3 Specific terms used in this EAD

1.3.1 Service duct

Mainly horizontal duct enclosing combustible or non-combustible services, such as pipes or cables.

1.3.2 Duct components

The pre-fabricated connecting pieces, special pieces and accessories as listed in section 1.1 are referred to hereinafter as duct components.

1.3.3 Service support construction

Mechanical support provided in the form of clips, ties, hangers, ladder racks or trays, or any device designed to carry the load of the services (installations).

1.3.4 Suspension devices of the service duct

Mechanical support provided in the form of suspended or fastened mounting rails, suspension brackets etc. designed to carry the load of the service duct.

1.3.5 Specific devices for inlet and outlet of cables or pipes

Devices for the inlet or outlet of cables or pipes into the service duct or out of the service duct. The devices can be a cable gland for a single cable or a specific piece with an opening and sealing for several cables or pipes (see clause 1.1).

² The real working life of a product incorporated in a specific works depends on the environmental conditions to which that works is subject, as well as on the particular conditions of the design, execution, use and maintenance of that works. Therefore, it cannot be excluded that in certain cases the real working life of the product may also be shorter than referred to above.

2 ESSENTIAL CHARACTERISTICS AND RELEVANT ASSESSMENT METHODS AND CRITERIA

2.1 Essential characteristics of the product

Table 2.1.1 shows how the performance of the kit for fire-resistant service ducts is assessed in relation to the essential characteristics.

Table 2.1.1 Essential characteristics of the kit for fire-resistant service ducts and methods and criteria for assessing the performance of the kit for fire-resistant service ducts in relation to those essential characteristics

No	Essential characteristic	Assessment method	Type of expression of product performance
Basic Works Requirement 2: Safety in case of fire			
1	Reaction to fire	2.2.1	Class
2	Propensity to undergo continuous smouldering of kit components	2.2.2	Description
3	Resistance to fire of the service duct	2.2.3	Class
4	Durability of the resistance to fire of the service duct		
4.1	Fire protective performance	2.2.4.1	Level
4.2	Resistance to the effects of higher temperatures	2.2.4.2	Level
4.3	Resistance to the effects of direct contact with metals and plastics	2.2.4.3	Level/description
4.4	Adhesion between the intumescent component and the substrate	2.2.4.4	Level/ description
4.5	Resistance to the effects of constant low temperatures (permanent frost)	2.2.4.5	Level
4.6	Heat insulation efficiency (ablative component)	2.2.4.6	Level
Basic Works Requirement 3: Hygiene, health and the environment			
5	Content and/or release of dangerous substances	2.2.5	Level/description

2.2 Methods and criteria for assessing the performance of the kit for fire-resistant service ducts in relation to essential characteristics of the product

This chapter is intended to provide instructions for TABs. Therefore, the use of wordings such as “shall be stated in the ETA” or “it has to be given in the ETA” shall be understood only as such instructions for TABs on how results of assessments shall be presented in the ETA. Such wordings do not impose any obligations for the manufacturer and the TAB shall not carry out the assessment of the performance in relation to a given essential characteristic when the manufacturer does not wish to declare this performance in the Declaration of Performance.

Testing will be limited only to the essential characteristics which the manufacturer intends to declare. If for any components covered by harmonised standards or European Technical Assessments the manufacturer of the component has included the performance regarding the relevant characteristic in the Declaration of Performance, retesting of that component for issuing the ETA under the current EAD is not required.

2.2.1 Reaction to fire of the kit components

The reaction to fire performance of the kit depends on the reaction to fire performance of its components and shall be assessed on that basis.

The reaction to fire performance shall be classified and indicated for all materials or components used for manufacturing the fire-resistant duct (e. g., steel sheets and intumescent materials or profiles, fastenings, insulation materials (mineral wool) or sealing products). Depending on the type of the component one of the following methods of assessment shall be used:

- a) The component is covered by another harmonised product specification. In this case, the reaction to fire performance shall be taken from its own declaration of performance, if such declaration is available and the related performance declared, as long as the conditions for which the classification is valid covers the application of the component in the kit.
- b) The component is considered to satisfy the requirements for performance class A1 of the characteristic reaction to fire in accordance with the Commission Decision 96/603/EC, as amended by Commission Decisions 2000/605/EC and 2003/424/EC, without the need for testing on the basis of it fulfilling the conditions set out in that Decision and its intended use being covered by that Decision.
Therefore, the performance class of the component is A1.
- c) The component is considered to satisfy the requirements for performance of the respective class of the characteristic reaction to fire in accordance with one of the Commission Decisions related to a classification without the need for further testing (CWT/CWFT Decisions) on the basis of it fulfilling the conditions set out in the respective Decision and its intended use being covered by that Decision.
Therefore, the performance depending on its type and the conditions under which the component is used shall be taken from the respective Decision applicable for the component.
- d) The component is considered to satisfy the requirements for small components in accordance with Annex C. In this case the component shall be considered as a small component and its reaction to fire performance can be neglected and doesn't need to be tested and classified separately.
- e) If none of the above cases a) to d) applies and testing of the component is necessary, the provisions concerning mounting and fixing of the test specimens as well as rules for the extended application of test results provided in the legal acts and specifications according to table 2.2.1.1 shall be taken into account.

The component shall then be tested, using the test method(s) relevant for the corresponding reaction to fire class according to EN 13501-1. The component shall be classified according to Commission Delegated Regulation (EU) No 2016/364 in connection with EN 13501-1.

Table 2.2.1.1 Basis for assessing the characteristic reaction to fire of the kit components where testing is needed

Component	Performance of the component	Determined according to
Galvanised or non-corrosive steel sheet with an optional external organic coating	class	Commission Decision 96/603/EC*
		Delegated Regulation (EU) 2016/364 in combination with EN 13501-1
Intumescent coating and gap filler	class	Delegated Regulation (EU) 2016/364 in combination with EN 13501-1 and EAD 350005-00-1104
Ablative coatings for annular gaps	class	Delegated Regulation (EU) 2016/364 in combination with EN 13501-1 and EAD 350402-00-1106
Insulation materials	class	Delegated Regulation (EU) 2016/364 in combination with EN 13501-1 and EN 15715
Suspension devices	class	Commission Decision 96/603/EC*
Boards, slabs or mats for inlets or outlets	class	Delegated Regulation (EU) 2016/364 in combination with EN 13501-1 and EAD 350142-00-1106

* as amended by Commission Decisions 2000/605/EC and 2003/424/EC

The reaction to fire performance for the components of the kit shall be given in the ETA or it shall be stated that a component does not need to be tested because it is considered to be a small component and its contribution to the reaction to fire performance of the kit shall be neglected.

2.2.2 Propensity to undergo continuous smouldering

The propensity to undergo continuous smouldering of kit components made of mineral wool, wood-based materials, vegetable/animal fibres or similar materials shall be tested and assessed according to EN 16733.

However, if these components are covered by a harmonised product specification, the performance shall be taken from the declaration of performance for the components in question, if such declaration is available and the related performance declared, and shall be stated in the ETA. Otherwise, the provisions given in Annex B apply.

2.2.3 Resistance to fire of the service duct

The service duct shall be tested in accordance with EN 1366-5.

If an inlet or outlet is part of the service duct and/or if the manufacturer intends to have the kit be assessed with steel cables and/or with those services which are intended to be used in practice the relevant test conditions shall be given in in the ETA.

For extended applications of the test results of the service duct according to the intention of the manufacturer see Annex A.

The test configuration shall correspond with the manufacturer's description of all installation conditions. This is related to

- the thickness and fire resistance of the adjacent building components,
- type and spacing of the suspension or fastening of the service duct,
- type and dimensions of the services,
- type and execution of the sealing of the connections and other components,
- the size and weight of the pre-fabricated connecting pieces and special pieces,
- the type of the services (when tested instead of steel cables),
- the weight of the services or steel cables arranged directly on the duct bottom,
- the fastening of the duct (type and spacing of the suspensions and fasteners).

The test results of the duct assembled from the kit may be used for service ducts which include all usual services. For service ducts with cable trays not tested with the duct this applies only to a maximum mass of loading equipment used for testing the service duct.

The assessment methods provided in this EAD are based on the assumption that the dimensioning of the steel suspensions and the calculation of their elongation have been carried out according to EN 1366-5, clause 13.5.

The service duct shall be classified in accordance with EN 13501-2. The class shall be stated in the ETA together with the information if tested with steel cables and/or with services and/or with inlets or outlets.

2.2.4 Durability of the resistance to fire of the service duct

2.2.4.1 Fire protective performance

The reactive component is decisive for the fire protective performance of the fire-resistant service duct. The difference in the properties of the reactive components before and after exposure to the conditions as described in Annex E is decisive in that respect. These properties shall be known for the reactive component.

The expansion ratio of an intumescent component shall be determined according to Annex D.6 in conjunction with Annex D.1; the expansion pressure shall be determined according to Annex D.7 in conjunction with Annex D.1. Testing shall be done before and after exposure according to Annex E.

The differences for the relevant levels as determined before and after exposure shall be given in the ETA as absolute or relative value or both.

Where an ablative component forms part of the kit and contributes to the fire protective performance of the kit for fire-resistant service ducts, this shall be determined according to Annex D.5 in conjunction with Annex D.1. Also in this case, the assessment shall be based on the comparison of the component characteristics before and after exposure according to Annex E. The difference of the levels determined before and after exposure shall be given in the ETA.

2.2.4.2 Resistance to the effects of higher temperatures

The performance of the reactive component is decisive for the performance of the kit with regard to this essential characteristic.

The reactive material may temporarily, occasionally or permanently be in contact with working cables or with pipes transporting hot substances. So, the reactive component of the kit shall not change essentially the characteristics like expansion ratio and/or the expansion pressure (if the component creates any pressure during the reaction) when exposed to higher temperatures.

The resistance to the effects of higher temperatures shall be tested and assessed according to Annex D.2 in conjunction with Annex D.1. The difference in characteristics like expansion ratios and the expansion pressure before and after exposure shall be stated in the ETA. If no expansion pressure could be measured, it shall be stated in the ETA (see Annex D.6 and D.7).

2.2.4.3 Resistance to the effects of direct contact with metals and plastics

The performance of the reactive component is decisive for the performance of the kit with regard to this essential characteristic.

The applied reactive component might be used permanently in direct contact with plastics (e.g., acrylic glue, plastic pipes) or metal (metal pipes, cables, the substrate). In this case chemical or physical exchange processes may occur between these plastic or metal elements and the reactive component and may influence the characteristics like expansion ratio and/or the expansion pressure.

The resistance to direct contact with metals and plastics shall be tested and assessed according to Annex D.3 in conjunction with Annex D.1. When there is a change in tensile strength more than 10%, the difference in tensile strength before and after exposure shall be stated in the ETA (absolutely and/or relatively).

After the test according to Annex D.3 has been done, the appearance of the metal specimens shall be examined (all visual changes shall be recorded, e.g., corrosion). The result shall be indicated in the ETA.

2.2.4.4 Adhesion between the reactive component and the substrate

The performance of the reactive component is decisive for the performance of the kit with regard to this essential characteristic. The adhesion shall be assessed on the substrate as described by the manufacturer.

The adhesion of the reactive component shall be tested after the intended climatic exposure at least in accordance with Annex E.4.

Note: Additional tests in accordance with Annex D.4 in conjunction with Annex D.1 can be done. The product performances assessed this way might be relevant for specific intended uses of the final product as, e.g., in chill rooms and refrigeration rooms or in other specific climates.

After the durability test the adhesion shall be tested in accordance with Annex D.4. The test for reactive coatings up to 3 mm shall be done in accordance with EN ISO 2409.

The test for laminated or glued reactive components shall be done in accordance with EN 28510-1.

The difference in classification (EN ISO 2409) or percentual difference in peel force (EN 28510-1) shall be given in ETA.

2.2.4.5 Resistance to the effects of constant low temperatures (permanent frost)

The performance of the reactive component is decisive for the performance of the kit with regard to this essential characteristic. If the product is intended to be exposed to permanent frost during final use the resistance of the reactive component to permanent frost shall be tested and assessed according to Annex D.4 in conjunction with Annex D.1.

The change of mass (in percent) before and after exposure shall be stated in the ETA.

2.2.4.6 Heat insulation efficiency (ablative component)

For the heat insulation efficiency of the ablative component the provisions of Annex D.5 in conjunction with Annex D.1 apply. The time for heat transmission delay caused by the reactive material shall be stated in the ETA.

2.2.5 Content, emission and/or release of dangerous substances of the kit components

The performance of the kit related to the emissions and/or release and, where appropriate, the content of dangerous substances shall be assessed on the basis of the information provided by the manufacturer³ after identifying the release scenarios taking into account the intended use of the product and the Member States where the manufacturer intends his product to be made available on the market.

The identified intended release scenarios for this product and intended use with respect to dangerous substances are:

IA1: Product with direct contact to indoor air.⁴

IA2: Product with indirect contact to indoor air (e.g., covered products) but possible impact on indoor air.⁵

³ The manufacturer may be asked to provide to the TAB the REACH related information which he shall accompany the DoP (cf. Article 6(5) of Regulation (EU) No 305/2011).

The manufacturer may not be asked to:

- provide the chemical constitution and composition of the product (or of constituents of the product) to the TAB, or
- provide a written declaration to the TAB stating whether the product (or constituents of the product) contain(s) substances which are classified as dangerous according to Directive 67/548/EEC and Regulation (EC) No 1272/2008 and listed in the "Indicative list on dangerous substances" of the SGDS, taking into account the installation conditions of the construction product and the release scenarios resulting from there.

Any information provided by the manufacturer regarding the chemical composition of the products is not to be distributed to EOTA or to the TABs.

⁴ Scenario IA1 is applicable for products which are in contact with indoor air in a way that dangerous substances could be released directly out of the product.

⁵ Scenario IA2 is applicable for products which are covered with other products but nevertheless could release dangerous substances to indoor air (e.g., products covered with porous/unsealed coverings incapable of avoiding migration, such as gypsum panels).

SVOC and VOC

For the intended use covered by the release scenario IA1 semi-volatile organic compounds (SVOC) and volatile organic compounds (VOC) shall be determined in accordance with EN 16516. The loading factor used for emission testing shall be $0.05 \text{ m}^2/\text{m}^3$.

The preparation of the test specimen is performed by using a representative sample of the product installed in accordance with the manufacturer's product installation instructions or in absence of such instructions the usual practice of the product installation. The size of the test specimen shall be chosen in consideration of the test chamber size and the intended loading factor (see above).

Once the test specimen has been produced, as described above, it should immediately be placed in the emission test chamber. This time is considered the starting time of the emission test.

The test results shall be recorded for the relevant parameters (e.g., chamber size, temperature and relative humidity, air exchange rate, loading factor, size of test specimen, conditioning, production date, arrival date, test period, test result) after 3 and/or 28 days testing.

The product performance shall be expressed in [mg/m^3 or $\mu\text{g}/\text{m}^3$] and stated in the ETA.

3 ASSESSMENT AND VERIFICATION OF CONSTANCY OF PERFORMANCE

3.1 System(s) of assessment and verification of constancy of performance

For the products covered by this EAD the applicable European legal act is Commission Decision 1999/454/EC, as amended by Commission Decision 2001/596/EC.

The system is 1 for any use except for uses subject to regulations on reaction to fire performance.

For uses subject to regulations on reaction to fire including, where relevant, the propensity to undergo continuous smouldering the applicable AVCP systems are 1, 3 or 4 depending on the conditions defined in the said Decision.

3.2 Tasks of the manufacturer

The cornerstones of the actions to be undertaken by the manufacturer of kits for fire-resistant service ducts in the procedure of assessment and verification of constancy of performance are laid down in Table 3.2.1.

The manufacturer (regarding the components he buys from the market with a Declaration of Performance) shall take into account the Declaration of Performance issued by the manufacturer of that component. No retesting is necessary.

Table 3.2.1 Control plan for the manufacturer; cornerstones

No	Subject/type of control	Test or control method	Criteria, if any	Minimum number of samples	Minimum frequency of control
Factory production control (FPC)					
1	Checking of the incoming materials and components <ul style="list-style-type: none"> - designation and relevant characteristics of the material or component - if possible, references to European and/or international standards, relevant specifications, declarations of performance - inspection of the delivery receipt 	Checking of the documents (especially, where relevant, the declaration of performance), thickness measurement, visual inspection for damages, Checking of the expansion ratio/foam height and, where relevant, expansion pressure of the intumescent component	Compliance with the requirements for materials or components Maintaining the constant level of the properties of the intumescent component	Laid down in the control plan	Every delivery
2	Application or lining of the steel sheet with the intumescent material	Visual control and specific tests	layer thickness, adhesion, moisture of the intumescent material; visual inspection for damages	Laid down in the control plan	Laid down in the control plan
3	Production of the duct components	Checking of geometry and measurement of dimensions, visual inspection	Compliance with dimensions and tolerances required	1	At the beginning of each production series. For large series: - once a day
4	Production /combination of the kit components	Checking of the components, end control	Compliance of the combination of the kit components with the intended use	1	each kit

3.3 Tasks of the notified body

The intervention of the notified body for reaction to fire including, where relevant, the propensity to undergo continuous smouldering is only necessary for products/materials for which a clearly identifiable stage in the production process results in an improvement of the reaction to fire classification and/or, where relevant, the propensity to undergo continuous smouldering (e.g., an addition of fire retardants or a limiting of organic material).

The cornerstones of the actions to be undertaken by the notified body in the procedure of assessment and verification of constancy of performance are laid down in Table 3.3.1.

Table 3.3.1 Control plan for the notified body; cornerstones

No	Subject/type of control	Test or control method	Criteria, if any	Minimum number of samples	Minimum frequency of control
Initial inspection of the manufacturing plant and of factory production control					
1	Inspection of the factory and factory production control as described in the control plan	Checking of devices, equipment and documentation within the framework of the FPC	See control plan	-	when starting a new production or product line
2	Where the intervention of the notified body with regard to reaction to fire is necessary because the conditions for the applicability of system 1 are fulfilled, the notified body will consider especially the clearly identifiable stage in the production process which results in an improvement of the reaction to fire classification (e.g., an addition of fire retardants or a limiting of organic material).	Verification of the complete FPC, to be implemented by the manufacturer	-	-	when starting a new production or product line

Continuous surveillance, assessment and evaluation of factory production control					
3	Continuous surveillance of factory production control. At least checking of <ul style="list-style-type: none"> - incoming materials - production process - storage - documentation 	See control plan	See control plan	See control plan	Once or twice a year*
4	Checking of the duct components	Checking of geometry and measurement of dimensions with specified dimensions (drawings), visual inspection of the duct components	Compliance with geometry, dimensions and tolerances required	1	Once or twice a year*
5	Where the intervention of the notified body with regard to reaction to fire is necessary because the conditions for the applicability of system 1 are fulfilled, the notified body will consider especially the clearly identifiable stage in the production process which results in an improvement of the reaction to fire classification (e.g., an addition of fire retardants or a limiting of organic material).	Verification of the controls carried out by the manufacturer on the raw materials, on the process and on the product as indicated in Table 3.2.1	-	-	Once or twice a year*

* Continuous surveillance, assessment and evaluation of factory production control shall be carried out twice per year. After at least one year of continuous surveillance without any irregularities to report, the notified body may reduce the frequency of surveillance to once per year provided that the production is not prone to errors.

4 REFERENCE DOCUMENTS

EN 13501–1:2018	Fire classification of construction products and building elements, Part 1: Classification using data from reaction to fire tests
EN 13501–2:2016	Fire classification of construction products and building elements, Part 2: Classification using data from fire resistance tests, excluding ventilation services
EN 1363-1:2020	Fire resistance tests – Part 1: General requirements
EN 1366-5:2021	Fire resistance tests for service installations – Part 5: Service ducts and shafts
EN 823:2013	Thermal insulating products for building applications; Determination of thickness
EN 1602:2013	Thermal insulating products for building applications; Determination of the apparent density
EN 10216-5:2015	Seamless steel tubes for pressure purposes - Technical delivery conditions - Part 5: Stainless steel tubes
EN 13820:2003	Thermal insulating materials for building applications — Determination of organic content
EN 15715:2010	Thermal insulation products - Instructions for mounting and fixing for reaction to fire testing - Factory made products
EN 16516:2020/2017 +A1:2020	Construction products - Assessment of release of dangerous substances - Determination of emissions into indoor air
EN 16733:2016	Reaction to fire tests for building products — Determination of a building product's propensity to undergo continuous smouldering
EN 28510-1:2014	Adhesives - Peel test for a flexible-bonded-to-rigid test specimen assembly - Part 1: 90° peel
EN 13381-4:2013	Test methods for determining the contribution to the fire resistance of structural members - Part 4: Applied passive protection to steel members
EN ISO 527-1:2019	Plastics - Determination of tensile properties - Part 1: General principles (ISO 527-1:2019)
EN ISO 527-3:2018	Plastics – Determination of tensile properties -Part 3: Test conditions for films and sheets (ISO 527-3:2018)
EN ISO 2409:2020	Paints and varnishes – Cross-cut test (ISO 2409:2020)
ISO 6829-1:2019	Metallic materials – Tensile testing – Part 1: Method of test at room temperature
ISO 11503:1995	Paints and varnishes; determination of resistance to humidity (intermittent condensation)
EAD 350003-00-1109:2014	Kit for fire resistant service ducts consisting of pre-fabricated connecting pieces (made of mechanically pre-coated steel sheet) and according accessories
EAD 350005-00-1104:2015	Intumescent products for fire sealing and fire stopping purposes
EAD 350142-00-1106:2017	Fire protective board, slab and mat products and kits
EAD 350402-00-1106:2017	Reactive coatings for fire protection of steel elements

ANNEX A RESISTANCE TO FIRE- FIELD OF DIRECT APPLICATION OF TEST RESULTS

A.1.1 Service ducts

A.1.1.1 Test results cover T-pieces, branches, direction changing pieces etc. using the same materials and construction techniques and the same fixing/suspension system.

A.1.1.2 Test results of service ducts with services not supported by a service support construction (i. e., with the services arranged on the bottom of the duct) are applicable to service ducts with services supported by a service support construction, but not vice versa.

A.1.1.3 Service ducts need to be tested only with fire exposure from inside provided that there are basic test results from both sides showing that tests with fire exposure from inside lead to more critical results than tests with fire exposure from outside the duct.

If the service duct is intended to contain combustible services in practice always tests with fire exposure from inside shall be performed.

A.1.1.4 Test results from duct components made of galvanised steel sheet are applicable to duct components made of stainless steel sheet provided that the comparability of the materials has been verified.

A.1.1.5 Tests of suspended service ducts are applicable to 4-sided service ducts directly fixed on walls without distance.

A.1.2 Wall constructions

A.1.2.1 General

Test results with standard supporting flexible wall constructions according to EN 1363-1 do not cover sandwich panel constructions and flexible walls where the lining does not cover the studs on both sides. Service ducts in such constructions shall be tested.

A.1.2.2 Flexible wall constructions

Test results obtained with a fire-resistant service duct passing through a standard supporting flexible wall construction according to EN 1363-1 are applicable to the same type of wall construction (with or without insulation) of at least the same thickness and classified fire resistance, provided that

- the number of board layers and the overall board layer thickness are equal or greater than those tested, and/or
- the insulation is non-combustible, and/or
- in flexible wall constructions with timber studs, no part of the duct component is closer than 100 mm to a stud, the cavity between the duct component and the stud is closed with a minimum of 100 mm of insulation of class A1 or A2 in accordance with EN 13501-1.

A.1.2.3 Rigid wall constructions

Test results obtained with a fire-resistant service duct assembled from a kit passing through a standard supporting flexible wall construction according to EN 1363-1 are applicable to walls made of concrete or masonry of at least the same thickness and classified fire resistance.

Test results obtained with a fire-resistant service duct assembled from a kit passing through a standard supporting wall construction made of masonry or concrete are applicable to the same type of wall of at least the same thickness, density and classified fire resistance.

ANNEX B PROPENSITY TO UNDERGO CONTINUOUS SMOULDERING

The propensity to undergo continuous smouldering of components made of mineral wool, wood-based materials, vegetable/animal fibres or similar materials shall be tested according to EN 16733. In addition, the following conditions and parameters shall be considered when performing sampling and preparing test samples:

- product variations of a product family (as defined by a certain combination of raw materials, e.g., type of binder and other additives/treatment, fibres etc., and produced in a certain production process) ⁶,
- organic content – where appropriate – e.g., mineral wool products - (in percentage per mass), to be determined by tests according to EN 13820 on at least five specimens,
- absolute organic content expressed in [kg/m³] – where appropriate (e.g., mineral wool products),
- density, e.g., to be determined by tests according to EN 1602,
- thickness, e.g., to be determined by test according EN 823 on at least three test specimens,
- fibre orientation,
- without any non-substantial facings, coatings or suchlike (< 1 mm, < 1 kg/m²) existing facings or coatings shall be removed when preparing the test specimens.

The tests shall be done without consideration of the intended end-use conditions, because propensity to continuous smouldering is hardly affected by end-use conditions. If clause 6.2.5 of EN 16733 applies, a permanent contact between the pieces shall be assured.

The results of tests considering the aforementioned parameters in fully are also valid for products:

- of the same defined product family,
- where appropriate, with the identical or lower absolute organic content expressed in [kg/m³], but not higher than the relative organic content expressed in [% per mass] as tested,
- with the following densities:
 - in case of products made of mineral wool:
 - with equal or lower density up to a tested density of 115 kg/m³
 - if tested density is higher than 115 kg/m³, can be applicable to lower density if additionally tested with a density of 100 kg/m³ (± 15 %)
 - in case of products made of other materials than mineral wool:
 - for the tested density only (± 10 %)
 - for all densities between those assessed, if the highest and lowest density were tested,
- with lower thickness and also with higher thickness when 100 mm thick specimens were tested,
- with all fibre orientations, if all relevant orientations had been tested,
- with any non-substantial (< 1 mm and < 1 kg/m²) facings or coatings or suchlike (e.g., metal profiles or sheets),
- for any end-use conditions.

If the test according to clause 11 of EN 16733 has been passed, it shall be stated in the ETA: "The product does not show propensity for continuous smouldering combustion". If the test according to clause 11 of EN 16733 has been failed, it shall be stated in the ETA: "The product shows propensity for continuous smouldering combustion" If the assessment was not possible according to clause 11 of EN 16733, it shall be stated in the ETA: "Assessment of the propensity for continuous smouldering combustion is not possible".

⁶ To permit the TAB to apply EXAP-rules for test results within the assessment, it is recommended that the manufacturer should provide (but he is not obliged to do it) sufficient information (e.g., on the basis of the composition of the product in question), allowing the TAB to determine which products or product variants shall be submitted to testing and to reduce the number of tests required.

ANNEX C REACTION TO FIRE – REQUIREMENTS FOR SMALL COMPONENTS

A component is considered as small component not contributing to the growth and spread of fire if it satisfies all of the following requirements:

- not made from class A1/A2 material,
- a mass ≤ 50 g,
- a size of ≤ 50 mm x ≤ 50 mm or a diameter of ≤ 57 mm (equal area size as for a rectangular size of ≤ 50 mm x ≤ 50 mm) and
- a distance ≥ 200 mm to similar components when forming part of a composite product and being situated on the surface of a product made of material of classes B, C, D, or E

or

completely embedded all-round in non-melting material of class A1 when used as small connecting part of a product consisting of various components and without any possibility to ignite or to propagate fire.

Where the conditions are not met regarding the distance to other similar components or the all-round covering by non-melting A1 materials, the component shall be tested as part of the relevant composite product.

ANNEX D ASSESSMENT OF THE REACTIVE COMPONENTS

D.1 Preparation and conditioning of specimen for the tests

D.1.1 Preparation and conditioning of specimens

All samples shall be prepared as the manufacturer recommended and as intended in practice (curing and curing period, exposure with protection as intended etc.). Where the reactive component cannot be tested without a substrate (e.g., sprayed coating), a substrate of the same material as the duct shall be used if not stated differently.

The samples shall be supported on racks or special devices (made of an inert material) to put them into the test chamber preferably in a vertical position, 20 mm separated from each other. The size of the sample shall be sufficient for at least 3 specimens for every test and for every option model (e.g., thinnest/thickest variation of thickness) or product modification.

Before and after environmental exposure the samples shall be conditioned at a temperature of $(23 \pm 3) ^\circ\text{C}$ and a relative humidity of $(50 \pm 5) \%$. The specimen for the tests shall be cut from the conditioned samples (exposed and unexposed).

Before and after exposure all samples shall be weighed. The change of weight, if any, shall be recorded. Visual changes in colour, texture etc. should be recorded.

After exposure and before the test the specimens shall be maintained in conditions of a temperature of $(23 \pm 3) ^\circ\text{C}$ and a relative humidity of $(50 \pm 5) \%$.

D.1.2 Assessment of the results

The results of the tests for the unexposed and for the exposed specimens shall be compared. This stipulates that the samples for the exposure tests shall be of the same quality as those for the tests of unexposed specimens. So, it would be an advantage, if all specimens are taken from the same sample but also the results from product testing for unexposed specimens may be used for this comparative purpose.

D.2 Effects of higher use temperatures

Due to the fact, that cables could generate higher temperature while working or pipes could transport hot media the reactive component should be resistant to higher temperatures in use. The propensity of the reactive component to change the ability to react in case of fire, when exposed permanently to higher temperature during the normal use, shall be tested.

If a reactive material/product in use is intended to be exposed permanently or repeatedly to $80 ^\circ\text{C}$, $90 ^\circ\text{C}$ or $100 ^\circ\text{C}$, the following test shall be used for assessment:

A temperature-controlled device is needed to set a constant test temperature (e.g., $80 ^\circ\text{C}$, $90 ^\circ\text{C}$ or $100 ^\circ\text{C}$).

The sample (size sufficient for at least 3 specimens for each intended test)⁷ shall be weighed before storing them in a vertical position into the pre-heated device at the constant temperature selected. The test sample shall be exposed for a period of 40 days to the expected temperature, e.g., $80 ^\circ\text{C}$. After exposure the sample should be weighed again.

The test temperature, the loss of weight and all observations (e.g., change in colour, in texture etc.) shall be recorded.

After the exposure the tests, e.g., for expansion ratio in accordance with D.6 in conjunction with D.1 and expansion pressure in accordance with D.7 in conjunction with D.1 or for heat insulation efficiency in accordance with D.5 shall be carried out to show whether a change in performance happened caused by high temperature and drying.

⁷ At least 3 specimens are required for each test. If more than one test is intended (e.g., expansion ratio and expansion pressure) the number of specimens will grow. So, the exposed sample/s shall be of sufficient size.

D.3 Effects in contact with metal or plastic

The basis of the following tests is a visual comparison done between exposed and unexposed specimens, in order to show the influence of the interactive effects by the change of appearance and to warn the observer that adverse effects could influence the function of the construction products (e.g., blistering, sweating, decomposition, delamination, change of shape and colour).

D.3.1 Permanent contact with metal

The test shall be carried out to discern an interactive effect of reactive products in contact with metal, e.g., normal steel, aluminium, copper, alloys. For testing the tensile strength ISO 6829-1 shall be used.

At least 3 unprotected specimens made of the selected metal, of the intended thickness and a size of approximately 20 mm x 100 mm shall be pressed directly into tight contact with a sample of the intended reactive material of the same size. The both sheets shall be fixed on each other by small clips made of an inert material. E.g., liquids shall be brushed or sprayed as a layer on the metal substrate.

The prepared specimens shall be stored in a horizontal position (reactive on the metal sheet) for a contact period of 40 days in the standard atmosphere of $(30 \pm 3)^\circ\text{C}$ and $(80 \pm 5)\%$ relative humidity. If other conditions are intended in practice, the intended conditions should be used.

D.3.2 Permanent contact with plastic

The test shall be carried out to discern an interactive effect of reactive products in contact with plastics, e.g., polyvinyl chloride (PVC), polyethylene (PE), polypropylene (PP) (substrate or adhesive for fixing). For testing the tensile strength EN ISO 527-1 (General principles) and if relevant EN ISO 527-3 (testing foils or films) shall be used.

The specimens of a size of approximately 150 mm x 40 mm made of the kind of plastics intended for the permanent contact (e.g., PVC, PE, PP etc.) shall be pressed directly into deep contact with a sheet of the intended reactive material of the same size. The both sheets shall be fixed on each other by small clips made of an inert material. Liquids shall be brushed or sprayed as a layer.

The prepared specimens shall be stored in a horizontal position (reactive on the plastic sheet) for a contact period of 40 days in the standard atmosphere of $(30 \pm 3)^\circ\text{C}$ and $(80 \pm 5)\%$ relative humidity. If other conditions are intended in practice, the intended conditions shall be used.

After the test the ability to react under the impact of fire of the reactive material shall be tested and the appearance of the plastic specimens shall be examined for changes. In addition, a comparative test of tensile strength of the exposed sample according to EN ISO 527 (exposed to contact/not exposed to contact) shall be carried out to decide whether there has been a deleterious effect or not.

D.4 Effects of constant low temperatures (permanent frost)

If a reactive component in use is intended to be exposed to permanent frost (e.g., chill rooms, refrigeration rooms), the following test shall be used to assess the relevant product performances.

A temperature-controlled chilling device is needed to set a constant temperature at $(-20 \pm 2)^\circ\text{C}$ at a dry atmosphere (relative humidity of $\leq 50\%$).

The sample (size sufficient for at least 3 specimens for each intended test) shall be stored in a vertical position into the pre-cooled device. The test sample shall be exposed to a constant temperature of $-20^\circ\text{C} \pm 2\text{ K}$ and at a relative humidity of $\leq 50\% \pm 5\%$ for a period of 40 days.

The temperature, the relative humidity and all observations shall be recorded.

After the exposure test the tests for expansion ratio or/and expansion pressure or heat insulation efficiency shall be carried out to show whether a change in performance happened caused by freezing.

Reactive coatings up to 3 mm shall be tested in accordance with EN ISO 2409; for laminated or glued reactive/intumescent components EN 28510-1 applies.

D.5 Heat insulation efficiency of the ablative component

D.5.1 General

This small-scale furnace fire test shall be carried out at a constant temperature of 500°C (tolerance $\pm 20^\circ\text{C}$).

The reactive specimens shall be stored for drying in standard atmosphere ($23 \pm 2^\circ\text{C}$ and $50\% \pm 5\%$ relative humidity) for a period of time as specified by the manufacturer.

Before exposing to heat, the specimens shall be weighed. The weight shall be recorded.

D.5.2 Specimens

The specimens shall consist of steel panels of a nominal thickness of 5 mm and a minimum of size 300 mm x 200 mm. A minimum number of two panels coated by the reactive (ablative) material shall be tested in comparison to a similar unprotected one.

D.5.3 Test Procedure

A temperature-controlled muffle oven being able to reach a stable temperature of at least 500 °C is needed (see General above).

The specimen may be tested individually or together with other in one test depending on the size of the oven. The specimen shall be placed in the opening of the oven properly sealed in a vertical position such that only the ablative layer is exposed to the heat. The panel shall be mounted in a frame which forms part of one side (wall) of the furnace. The protected surface (covered with the reactive material) shall be faced to the heat.

The non-fire side shall be covered using vermiculite or calcium silicate board with a minimum of 50 mm thickness with a density of $475 \pm 25 \text{ kg/m}^3$.

Two thermocouples shall be attached to the non-fire side of the steel panels. These thermocouples shall be located close to the centre in a distance of 2 cm. The thermocouples shall be of the K type according to EN 1363-1 but without a copper disc and without an insulation pad. The thermocouples shall be fixed to the back of the steel panels by welding following the EN 13381-4:2013.

D.5.4 Result

The test is finished when the temperature of the two thermocouples reaches 280 °C.

The time for reaching this temperature shall be recorded for the protected and the unprotected panel separately. The difference of this time is a criterion for heat transmission delay caused by the reactive material and shall be recorded.

D.6 Determination of the expansion ratio of the intumescent component

The expansion ratio shall be determined on at least 6 specimens to assess the ability of the material to create a foam/char in the event of fire. The mean value and the standard deviation shall be recorded.

The original thickness of the dried specimen shall be measured.

The thickness shall be determined after expansion again. If the expansion of the material is not uniform, the thickness after expansion shall be determined from the average value of the maximum and minimum thickness.

D.6.1 General

The principle of testing the expansion ratio is to expose an intumescent material to a certain temperature for a particular duration, to restrict the expansion to one direction, to measure the changed thickness after expansion (foam height) and to express this in relation to the original thickness (before heat exposure).

Suitable apparatus and equipment to determine the foam height are shown in figure D.6.1.

If the specific intumescent material is used in the kit in more than one nominal thickness or more than one nominal density, the maximum thickness/density and the minimum thickness/density shall be tested. The expansion ratio depends on the thickness and/or the density of the specimen and can differ for different thicknesses/densities. The ETA shall give the test results for the component as intended to be used in the kit and as tested.

Pastes, mortars, stoppers and putties shall be tested preferably with a maximum thickness of approximately 5 mm and coating materials with a thickness of approximately 2 mm.

D.6.2 Determination of the suitable test temperature

The test temperature required for the determination of the foam height of a specific intumescent material shall be determined in pre-tests.

In order to find out the appropriate test temperature for the specific intumescent material, the temperature in the oven shall be increased in steps of 50K (300°C, 350°C, 400°C, 450°C etc). Leave the specimens in the oven until the material has completely reacted.

The duration of the test depends on the intumescent capacity of the material and can differ at different temperatures. Normally 30 minutes are considered as suitable. It is useful to set the test temperature so that the sample can foam up completely in an acceptable time.

|

The determined test temperature and the relating time of exposure to heat shall be recorded and shall be used for all further tests for determining the foam height of this specific material.

D.6.3 Test method

D.6.3.1 Preparation of the specimens

At least six circular specimens of a diameter corresponding to the inner diameter of the specimen holder with a tolerance of $\pm 0,5$ mm shall be cut out of the intumescent material. The thickness of the sample shall be measured with an accuracy of 0,1 mm at the centre of the disc and at four symmetrically placed positions ca. 10 mm from the edge of the specimen. The mean value shall be recorded together with the standard deviation.

For intumescent materials in the form of powder or granules the weight of the specimens and the filling height shall be determined.

If necessary, the thickness of the specimens shall be reduced such that the foam height does not exceed the height of the specimen holder. Such handling shall be recorded.

D.6.3.2 Test procedure

A temperature-controlled muffle oven being able to reach a stable temperature of at least 600°C is needed. The oven shall be pre-heated to the stable temperature as required for the test and as determined during the pre-test.

The specimen shall be placed into the specimen holder of the test device (figure D 6.1).

The test device shall be placed quickly (to minimise heat loss) into the centre of the muffle oven at the particular temperature for the pre-defined duration. The test temperature shall be re-established within 5 minutes in the oven.

Wearing protective clothing and gloves the test device shall be removed from the oven as soon as reasonably practicable after the test. The foam height shall be determined within 5 minutes after the specimens have been removed from the oven.

D.6.3.2.1 Test deviceKey

C	specimen holder	E	lower frame
D	upper frame	F	spacer bar

Pipes: according to EN 10216-5, wall thickness 2 mm

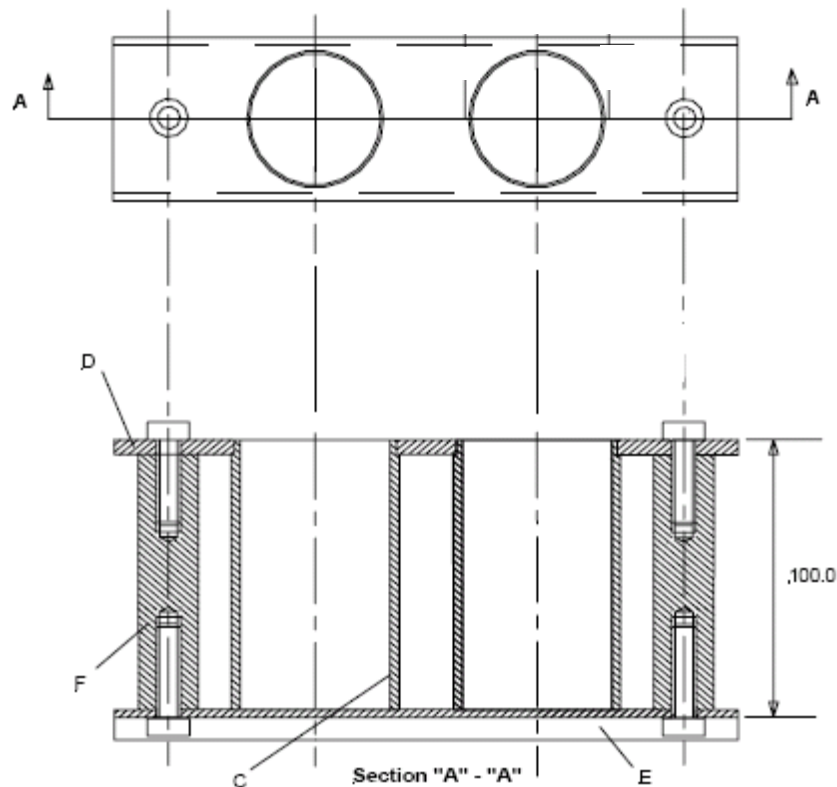

Figure D.6.1 – Test device

D.6.3.2.2 Test method**modification 1:**

For this method circular weights (5g; 10g, 20g, 50g, 100g etc.) of a diameter corresponding to the specimen holder shall be put on top of the specimen before testing. After exposure to heat the height of the lower surface of the lifted weight shall be equated with the foam height. This modification shall be used for components reacting violently and effervescently.

modification 2:

For this modification no weights are used and the foam will expand freely in one direction in the specimen holder. After the heat exposure the measurements shall be carried out at five points symmetrically arranged with one central as done before testing (see "Preparation of the specimens"). This modification shall be used for components reacting slowly and leisurely.

For both methods the mean value of the measurement represents the "foam height" at a certain temperature after a certain time of heat exposure. Minor voids or cavities within the structure of the foamed specimens shall not to be taken into consideration.

The expansion ratio is the quotient of the mean value of thickness of an expanded specimen of the intumescent specimen divided by the mean value of the original thickness of the same specimen before expansion.

D.7 Determination of the expansion pressure of the intumescent component

The expansion pressure shall be determined on at least 6 specimens to assess the ability of the material to develop pressure during the chemical reaction. The mean value and the standard deviation shall be recorded.

D.7.1 General

If the specific intumescent material is used of more than one thickness or more than one density, the maximum thickness/density and the minimum thickness/density shall be tested.-

D.7.2 Preparation of the specimens

At first the fresh pasty/viscose/liquid reactive material shall be brought on a plane plate in a certain thickness. The hardened sample shall be peeled off. At least 6 circular specimens of a diameter of at least 50 mm (corresponding to diameter of the used steel ring) with a tolerance of $\pm 0,5 \text{ mm}^8$, shall be taken from the peeled off intumescent material. The thickness of the specimens shall be measured with an accuracy of $\pm 0,1 \text{ mm}$ at the centre of the disc and at four symmetrically placed points approximately 10 mm from the edge of the specimens. The mean value shall be recorded with the standard deviation.

For intumescent materials being tested in the ring necessarily the weight of the specimens shall be determined.

D.7.3 Test procedure

The measuring device for determining the expansion pressure acts at given temperatures (normally 300°C or 350°C) and shall be pre-heated to that temperature. The sample shall be built into a frame consisting of a base plate (1), two pillars (2) and a pressure plate (3).

The heated upper pressure receptor (13) is rigid during the test but can be swung out for cleaning purposes, is connected with the frame through a guide system (5, 6, 7). In order to enable the specimens to be quickly inserted, the top plate can be adjusted in height by 15 mm by means of the lever (8, 9).

The heated lower pressure receptor (14) transmits the force occurring during the test via a transmission device to the force transducer (10) mounted on the base plate.

The transmission device has a hand wheel adjustment that allows a specimen thickness of up to 32 mm. The spindle (11) serves as a locking device for the mechanism.

D.7.4 Preparation of the test device

In the neutral/zero position of the heating plates a pre-pressure of approximately 60 N shall exist. The starting positions for the heating plates required for the test and the appropriate spacing between them shall be established by measurement. The setting will take into account the thickness of the specimen.

The heating plates shall be spaced 1 mm greater than the height of the steel ring in use to avoid prepressuring the specimen and to compensate for uneven foaming at the beginning of the test.

Note: It is a direct input of temperature into the sample which is between the heated plates for pressure measuring, so the thickness of the specimen shall be considered. The space of ca. 1mm does not play any role for the heat transmission in this device.

D.7.5 Test device

Key

1 base plate	6 guide system	11 spindle
2 pillars	7 guide system	12 hand wheel
3 pressure plate	8 lever	13 heated upper pressure receptor
4 top-plate	9 lever	14 Heated lower pressure receptor
5 guide system	10 force transducer	

⁸ The specimen should be as large as possible to reduce the edge influences, but the actual size will depend on the apparatus (e.g., ring size).

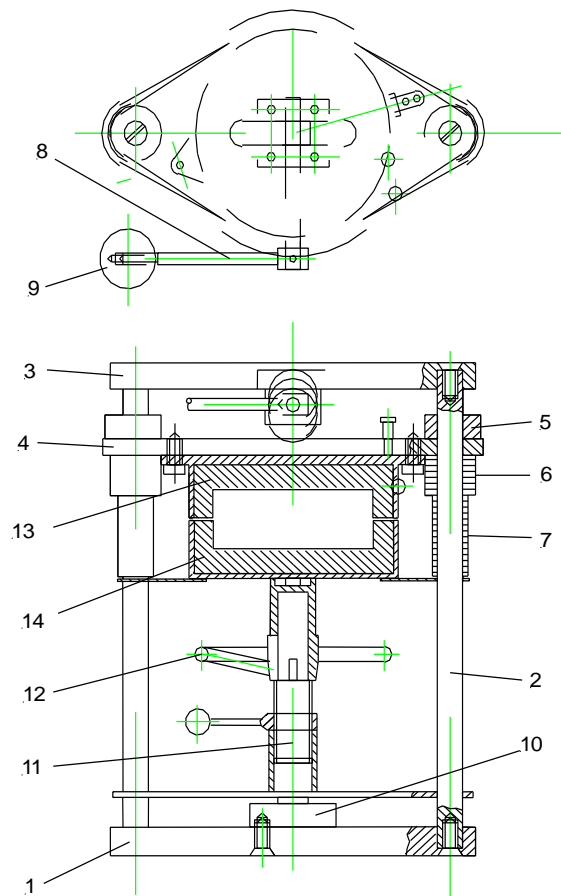

Figure D.7.1 - Test device

D.7.6 Test method: Testing with lateral restriction

The specimens shall be placed into two steel rings, which match the size of the specimen to be tested. The internal diameter of steel rings made of stainless steel shall have a tolerance of + 0,2/ - 0 mm.

The steel rings shall have a nominal height of 4 mm or 9 mm (tolerance + 0,1 mm). The specimens will then have a maximum height of 5 mm or 10 mm respectively.

The specimen shall be placed in the steel ring centrally between two aluminium foils (50µm thick) into the apparatus according to figure D.7.1.

D.7.7 Measurement of the expansion pressure and evaluation of the results

The expansion pressure [N/mm²], temperature and time elapsed shall be continuously recorded. The test is performed until the maximum pressure is clearly exceeded, but not longer than 10 min.

The maximum expansion pressure shall be recorded for the thickness tested.

ANNEX E DURABILITY OF THE INTUMESCENT COMPONENTS

E.1 Standard test conditions for the final use of intumescent components

The durability of reactive products may change significantly when exposed to specific use conditions. This change may result in a product not achieving the expected performance.

When a product is subject to further processing, e.g., encapsulation in waterproof casings, the durability tests shall be conducted in accordance with the product specification.

The following types of final intended use conditions are considered to be relevant for reactive components in the product described and shall be tested correspondingly:

Type Y₂: product intended for use at temperatures below 0 °C (occasionally), but with no exposure to wetness, rain or UV (exception: re-drying short-term condensation)

Type Z₁: product intended for use at internal conditions with high humidity (permanent, changing or temporary condensation), excluding temperatures below 0 °C

Type Z₂: product intended for use at internal conditions with relative humidity lower than 85 % rh (relative humidity) excluding temperatures below 0 °C (frost-free and dry).

The assessment results after conditioning of type Y₂ can be extended to use conditions of type Z₁ and Z₂; the results after testing Type Z₁ can be extended to type Z₂.

E.2 Testing at conditions of type Y₂

To be able to assess the performance of the reactive material/product intended to be used for internal and sheltered external conditions (no UV, no rain) the following tests shall be carried out:

A sample for at least 3 specimens as required for testing the expansion ratio and 3 specimens for testing the expansion pressure after exposure shall be stored in a vertical position in a controlled environmental chamber and shall be exposed 3 times to the conditions according to the cycle given in table E.2.1, thus in total for 21 days without interruption.

After the exposure the specimens shall be cut from the sample and shall be tested according to the test, e.g., for expansion ratio and/or expansion pressure.

Tab E.2.1 Exposure condition cycle for reactive products without any temperature restriction

period/ day	6 hour phase			
	1 st (6 hours)	2 nd (6 hours)	3 rd (6 hours)	4 th (6 hours)
1. + 2.	(20 ± 3)°C, saturated relative humidity	(70 ± 3)°C, (20 ± 5)% relative humidity	(20 ± 3)°C, saturated relative humidity	(70 ± 3)°C, (20 ± 5)% relative humidity
3. + 4.	(20 ± 3)°C, saturated relative humidity	(30 ± 3)°C, (40 ± 5)% relative humidity	(40 ± 3)°C, saturated relative humidity	(30 ± 3)°C, (40 ± 5)% relative humidity
5. + 6 + 7	(- 20 ± 3)°C	(40 ± 3)°C, saturated relative humidity	(- 20 ± 3)°C	(40 ± 3)°C, Saturated relative humidity

Note

The chamber temperature change shall be at a rate of (1,5 ± 0,5) K/min. During the period of temperature change the change of humidity is not controlled, but condensation shall be avoided. The duration of temperature change is included in the duration of an exposure phase.

E.3 Testing at conditions of type Z₁

For this test an airtight cabinet or chamber as described in EN ISO 11503 should be used.

A sample for at least 3 specimens as required for the tests shall be stored preferably in a vertical position in an environmental chamber for 21 days and exposed to the following procedure without interruption:

- 8 hours at (40 ± 3)°C and 98 % to 100 % relative humidity followed by

- 16 hours at $(23 \pm 3)^\circ\text{C}$ and $(50 \pm 5)\%$ relative humidity⁹

After the exposure the specimens shall be cut from the sample and shall be tested according to the test, e.g., for expansion ratio and/or expansion pressure¹⁰.

E.4 Testing at conditions of type Z₂ (normally dry conditions without frost)

For this test the specimens shall be cut out from a sample before exposure. The specimens shall be of the same dimensions and size as required for the tests.

At least 3 specimens as required for the tests shall be stored preferably in a vertical position in an environmental chamber for 21 days and exposed to the following cycle:

- 4 h at $(5 \pm 3)^\circ\text{C}$ and $(50 \pm 5)\%$ relative humidity
- 4 h at $(23 \pm 3)^\circ\text{C}$ and $(80 \pm 5)\%$ relative humidity
- 16 h at $(40 \pm 3)^\circ\text{C}$ and $(50 \pm 5)\%$ relative humidity

This test shall be repeated for 21 cycles without interruption.

After the exposure the specimens shall be cut from the sample and shall be tested according to the test, e.g., for expansion ratio and/or expansion pressure.

⁹ In practise it is common to open the chamber door if the ambient conditions meet the temperature of $23^\circ\text{C} \pm 3 \text{ K}$.

¹⁰ Specific deviations and modifications concerning the conditioning, the shape and size of the specimen, the exposure conditions and the test/s shall be recorded.