

EUROPEAN ASSESSMENT DOCUMENT

EAD 160124-00-0301

March 2019

NON-SCREWABLE SLEEVE FOR MECHANICAL SPLICES BY LATERAL COMPRESSION OF REINFORCING BARS

The reference title and language for this EAD is English. The applicable rules of copyright refer to the document elaborated in and published by EOTA.

This European Assessment Document (EAD) has been developed taking into account up-to-date technical and scientific knowledge at the time of issue and is published in accordance with the relevant provisions of Regulation (EU) No 305/2011 as a basis for the preparation and issuing of European Technical Assessments (ETA).

Contents

1	Scope of the EAD	4
1.1	Description of the construction product	4
1.2	Information on the intended use(s) of the construction product	5
1.2.1	Intended use(s).....	5
1.2.2	Working life/Durability.....	5
1.3	Specific terms used in this EAD	6
1.3.1	Symbols.....	6
2	Essential characteristics and relevant assessment methods and criteria	8
2.1	Essential characteristics of the product	8
2.2	Methods and criteria for assessing the performance of the product in relation to essential characteristics of the product	8
2.2.1	Tensile properties.....	9
2.2.2	Slip.....	10
2.2.3	High-cycle fatigue.....	12
2.2.3.1	Static application.....	12
2.2.3.2	Dynamic application.....	13
2.2.4	Low-cycle fatigue: Alternating tension and compression test of high stresses in the mechanical splice.....	14
2.2.5	Low-cycle fatigue: Alternating tension and compression test of large strains in the mechanical splice.....	15
2.2.6	Reaction to fire.....	16
3	Assessment and verification of constancy of performance	17
3.1	System(s) of assessment and verification of constancy of performance to be applied	17
3.2	Tasks of the manufacturer	17
3.3	Tasks of the notified body	17
4	Reference documents	19

1 SCOPE OF THE EAD

1.1 Description of the construction product

This EAD covers non-screwable sleeves for mechanical splices by lateral compression of reinforcing bars (in the following referred to as sleeves). The sleeve is a device for joining bars used in reinforced concrete structures. It transfers axial compression and/or tension from one bar to the other or from one end to the other of the same rebar.

The sleeve may have a square section and a central hole, which allows the bars to pass. In the upper part, the sleeve is equipped with high strength steel nails or with metal tablets. The sleeve may also have a not-squared section, but at least the bottom surface is plan.

The sleeve has a centring hole on the lateral surface to check the exact position of the bars during installation.

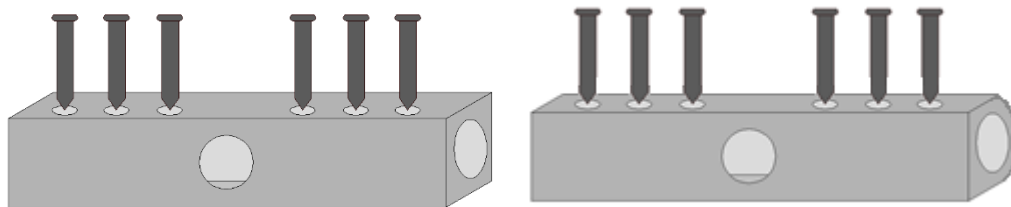

Figure 1.1-1: Example of sleeves: square section and bended side

In the upper part of the sleeve, high strength steel nails are fixed in special holes and they compress the reinforcing bars laterally. The nails are positioned to generate a gradually increasing lateral compression towards the central part of the rebar section. The internal hole has a surface indented by a thread that has the purpose of increasing the friction on the reinforcing bar.

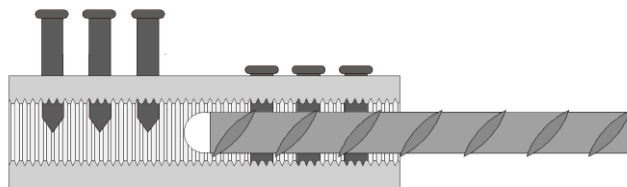

Figure 1.1-2: Sleeve section and bar positioning

The lateral compression can also be applied by metal tablets that work in the same way as the nails.

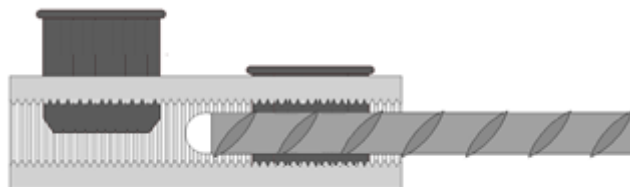

Figure 1.1-3: Lateral compression generated by metal tablets



Figure 1.1-4: Lateral compression on the bar

The sleeves covered by this EAD are completely made of galvanized steel.

The product is not covered by a harmonised European standard (hEN).

Concerning product packaging, transport, storage, maintenance, replacement and repair it is responsibility of the manufacturer to undertake the appropriate measures and to advise his clients on the transport, storage, maintenance, replacement and repair of the product as he considers necessary.

It is assumed that the product will be installed according to the manufacturer's instructions or (in absence of such instructions) according to the usual practice of the building professionals.

Relevant manufacturer's stipulations having influence on the performance of the product covered by this European Assessment Document shall be considered for the determination of the performance and detailed in the ETA.

1.2 Information on the intended use(s) of the construction product

1.2.1 Intended use(s)

The sleeves are used as couplings for reinforcing bars.

The sleeve can join longitudinal bars as an alternative to the overlapping of the bars to allow structural continuity both in new reinforced concrete constructions and retrofitting of existing construction works. The sleeve can also join steel stirrups used for both new reinforced concrete constructions and retrofitting of existing construction works.

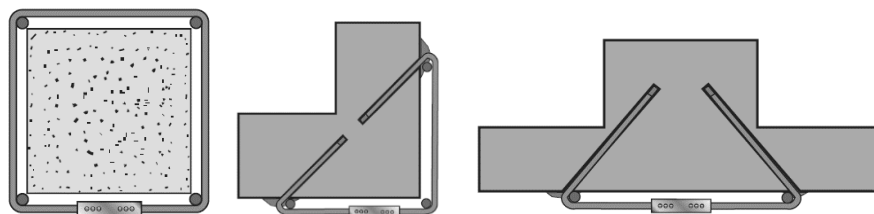

Figure 1.2.1-1: Fixing of steel stirrups in retrofitting of existing construction works

The sleeve is intended to be used to join straight-length reinforcing bars and rebars obtained from coil and then straightened (de-coiled rebars).

This EAD applies to the use in concrete structures with static, dynamic and seismic loading.

1.2.2 Working life/Durability

The assessment methods included or referred to in this EAD have been written based on the manufacturer's request to take into account a working life of the sleeve for the intended use of 100 years when installed in the works (provided that the sleeve is subject to appropriate installation). These provisions are based upon the current state of the art and the available knowledge and experience.

When assessing the product, the intended use as foreseen by the manufacturer shall be taken into account. The real working life may be, in normal use conditions, considerably longer without major degradation affecting the basic requirements for works¹.

The indications given as to the working life of the construction product cannot be interpreted as a guarantee neither given by the product manufacturer or his representative nor by EOTA when drafting this EAD nor by the Technical Assessment Body issuing an ETA based on this EAD, but are regarded only as a means for expressing the expected economically reasonable working life of the product.

1.3 Specific terms used in this EAD

1.3.1 Symbols

For the purpose of this EAD, the following symbols shall apply.

A_{gt}	[%]	Total elongation at maximum tensile force
d	[mm]	Nominal diameter of the bar
E	[MPa]	Young's modulus for steel rebars
k_1	-	Stress exponent of the finite fatigue life (slope of the S-N curve before N^*)
k_2	-	Stress exponent of the infinite fatigue life (slope of the S-N curve after N^*)
s	[mm]	Slip
s_G	[mm]	Elongation over the gauge length in slip test
$s_{G,m}$	[mm]	Measured elongation over the gauge length in slip test
$s_{G,th}$	[mm]	Theoretical elastic elongation over the gauge length in slip test
s_S	[mm]	Elongation over the length of the mechanical splice in slip test
f_R	-	Relative rib area for rebar
L	[mm]	Length of the mechanical splice
L_1	[mm]	Distance between the last visible changes in the reinforcing bar profile near the sleeve
L_f	[mm]	Minimum required free length for the specimen
L_g	[mm]	Gauge length
N	-	Specified number of load cycles in fatigue test
N^*	-	Reference value for the number of cycles until fatigue failure in the S-N curve
$R_{e,nom}$	[MPa]	Nominal yield strength of the reinforcing bar
S_n	[mm ²]	Nominal section of the reinforcing bar

¹ The real working life of a product incorporated in a specific works depends on the environmental conditions to which that works is subject, as well as on the particular conditions of the design, execution, use and maintenance of that works. Therefore, it cannot be excluded that in certain cases the real working life of the product may also be shorter than referred to above.

U_4, U_8, U_{20}	[mm]	Residual elongation after 4, 8 and 20 cycles in low-cycle fatigue test
ε_y	[%]	Strain at yield strength of reinforcing bar
σ_{max}	[MPa]	Upper stress level for the high-cycle fatigue test
$\sigma_{f,u}$	[MPa]	Ultimate strength in low-cycle fatigue test
$\sigma_{t,u}$	[MPa]	Ultimate strength in tensile test
$2\sigma_a$	[MPa]	Stress range in high-cycle fatigue test

2 ESSENTIAL CHARACTERISTICS AND RELEVANT ASSESSMENT METHODS AND CRITERIA

All undated references to standards or to EADs in this EAD are to be understood as references to the dated versions listed in chapter 4.

2.1 Essential characteristics of the product

Table 2.1.1 shows how the performance of the non-screwable sleeves for mechanical splices by lateral compression of reinforcing bars is assessed in relation to the essential characteristics.

Table 2.1.1 Essential characteristics of the product and methods and criteria for assessing the performance of the product in relation to those essential characteristics

No	Essential characteristic	Assessment method	Type of expression of product performance
Basic Works Requirement 1: Mechanical resistance and stability			
1	Tensile properties	2.2.1	<i>Level</i> $A_{gt} [\%]; \sigma_{t,u} [MPa]$
2	Slip	2.2.2	<i>Level</i> $s [mm]$
3	High-cycle fatigue	2.2.3	<i>Level</i> - N for static applications; - $S-N$ curve, $k1$ and $k2$ for dynamic applications.
4	Low-cycle fatigue: Alternating tension and compression test of high stresses in the mechanical splice	2.2.4	<i>Level</i> $U_{20} [mm]; \sigma_{f,u} [MPa]$
5	Low-cycle fatigue: Alternating tension and compression test of large strains in the mechanical splice	2.2.5	<i>Level</i> $U_4 [mm]; U_8 [mm]; \sigma_{f,u} [MPa]$
Basic Works Requirement 2: Safety in case of fire			
6	Reaction to fire	2.2.6	<i>Class</i>

2.2 Methods and criteria for assessing the performance of the product in relation to essential characteristics of the product

This chapter is intended to provide instructions for TABs. Therefore, the use of wordings such as “shall be stated in the ETA” or “it has to be given in the ETA” shall be understood only as such instructions for TABs on how results of assessments shall be presented in the ETA. Such wordings do not impose any obligations for the manufacturer and the TAB shall not carry out the assessment of the performance in relation to a given essential characteristic when the manufacturer does not wish to declare this performance in the Declaration of Performance.

The specimen shall be prepared according to the installation instructions of the manufacturer.

The specimen shall be sufficiently long to ensure a free length between the grips of the testing machine to allow the determination of the total elongation at maximum tensile force A_{gt} [%]. The following free lengths L_f [mm] are the minimum required lengths for the specimen:

- For $d < 25 \text{ mm}$: $L_f = 250 \text{ mm} + L$
- For $d \geq 25 \text{ mm}$: $L_f = 200 \text{ mm} + 2d + L$

Where L [mm] is the length of the mechanical splice and d [mm] is the nominal diameter of the reinforcing bars. The length of the mechanical splice (L) is the distance between the last visible changes in the reinforcing bar profile near the sleeve (L_1) plus two nominal diameters at both ends (see Figure 2.2-1).

The length of the mechanical splice L [mm] is a theoretical definition aimed at including the length of bar that could have been affected by the bar-end process.

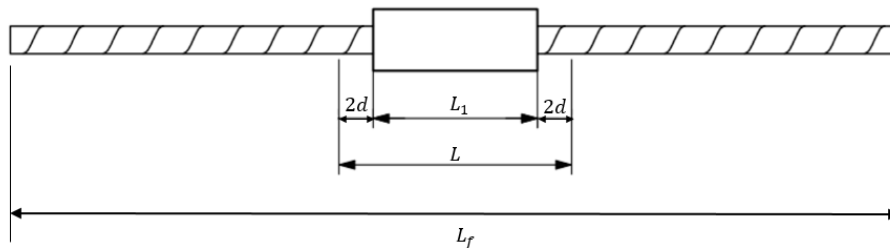

Figure 2.2-1: Free length of the specimens to be used for the tests

The sleeve shall be positioned in the middle of the test piece.

All tests are done joining rebars with properties according to Annex C of EN 1992-1-1 with a relative rib area f_R according to EN ISO 15630-1.

For the reinforcing bars, the value of f_R shall be chosen in the range reported in Table 2.2.1.

Table 2.2.1 Ranges of f_R values for the rebars

Nominal bar diameter [mm]	Minimum value of relative rib area f_R (EN 1992-1-1)	Maximum value of relative rib area f_R
$5 < d \leq 6$	0.035	0.100
$6 < d \leq 12$	0.040	
$d > 12$	0.056	

The tests shall be performed for each size per material and per type of sleeve, for each rebar diameter per type of steel (yield strength) and for each rebar type (straight-length rebar and de-coiled rebar).

2.2.1 Tensile properties

Purpose of the assessment

The purpose of the assessment is the evaluation of the tensile properties of the sleeve when used to join rebars.

Assessment method

The test shall be carried out according to EN ISO 15630-1, clause 5.

The elongation at maximum force A_{gt} [%] shall be measured according to EN ISO 15360-1, outside the length of the mechanical splice on each of the joined bars. Both values shall be recorded and the largest shall be used.

For the reinforcing bars, the value of f_R has to be chosen as described in clause 2.2.

The rib spacing and the rib height of the reinforcing bars shall be reported in the ETA.

Minimum 5 tests shall be performed.

The specimens of the slip test (clause 2.2.2) may also be used for this test.

Expression of results

The failure may occur according to the following three modes:

- a) At the grips of the testing machine, in a length between the grips of maximum $1xd$. In this case, the test can be considered not valid.
- b) Within the length of the mechanical splice (as defined in clause 2.2).
- c) Outside the length of the mechanical splice (as defined in clause 2.2).

The average value and the minimum value of the elongation at maximum force A_{gt} [%] and the average, characteristic and minimum values of the tensile strength $\sigma_{t,u}$ [MPa] shall be reported in the ETA with the corresponding failure mode. If the failure occurs within the length of the mechanical splice, A_{gt} [%] cannot be measured. In this case, A_{gt} [%] may be measured on a separate bar of the same heat at the same load level as the spliced bar. The effective tensile strength value of the unspliced reinforcing bar used for the test shall be reported in the ETA as average value obtained on at least three test specimens according to the test method described in this clause.

The tensile strength $\sigma_{t,u}$ [MPa] shall be evaluated on the basis of the nominal section of the bar S_n [mm²].

The characteristic value will be determined by using the appropriate value of k_n for unknown V_x reported in EN 1990, Annex D, Table D1.

2.2.2 Slip

Purpose of the assessment

The purpose of the assessment is the evaluation of the slip, which is the non-linear permanent elongation of the mechanical splice under loading.

Assessment method

The test shall be performed as follows:

- Tension pre-loading of the specimens is not permitted before starting the test.
- The stress shall be equivalent to $0.6 \cdot R_{e,nom}$. The load shall be determined on the basis of the nominal section of the bar S_n [mm²].
- The tensile testing machine to be used shall comply with clause 9 of EN ISO 6892-1.
- The slip shall be measured with an accuracy of 0.01 mm.
- The extensometers shall be of class 2 or better according to EN ISO 9513. The extensometers used to determine the slip shall be at least a two-point (averaging) type, but preferably a three-point (averaging) type.
- The gauges shall be set to zero after closing the clamps of the testing machine.
- The load cycle shall be applied as represented in Figure 2.2.2-1. The maximum tensile stress cannot vary more than 3%. The measurement shall be performed when the specified tensile stress at the third cycle is attained.
- The loading and unloading speed shall comply with clause 10.3.2.1 and 10.3.2.4 of EN ISO 6892-1 (Method A).

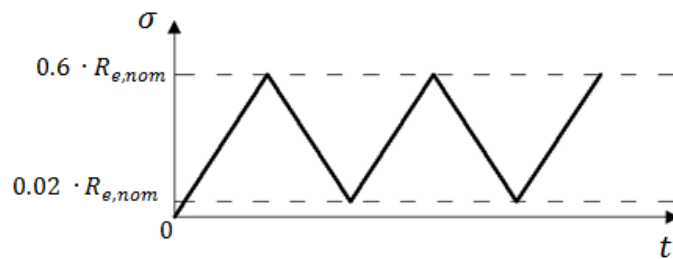

Figure 2.2.2-1: Load cycle for the slip test

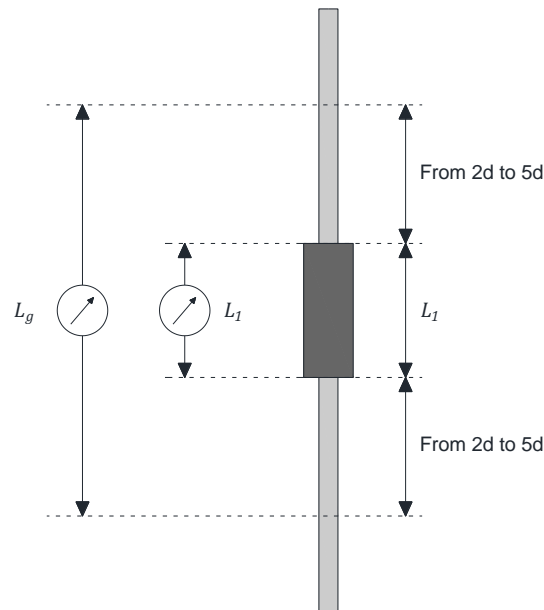

Figure 2.2.2-2: Slip measurement procedure

For the reinforcing bars, the value of f_R has to be chosen as described in clause 2.2.

The rib spacing and the rib height of the reinforcing bars shall be reported in the ETA.

Minimum 5 tests shall be performed.

The same specimens used for this test can be used for the tensile test (clause 2.2.1).

Expression of results

The slip is the difference between the elongation over the gauge length and the elongation of the mechanical splice. For each position, the value of the elongation is the difference between the measured elongation and the theoretical elastic elongation of the unspliced bar.

The slip s [mm] is, therefore, determined as follows:

$$s = s_G - s_S$$

where:

$s_G = s_{G,m} - s_{G,th}$: elongation over the gauge length L_g [mm];

s_S : elongation over the length of the sleeve L_1 [mm]

and

$s_{G,m}$: measured elongation over the gauge length L_g [mm];

$s_{G,th} = \frac{\sigma}{E} \cdot L_g$: theoretical elastic elongation over the gauge length L_g [mm];

L_g : gauge length [mm]. It is equal to L_1 plus a length between $2d$ and $5d$ ⁽¹⁾

$\sigma = \frac{4F}{\pi d^2}$: applied stress [MPa]

F : applied force [N]

E : Young's modulus of the rebar considered to be 2.0×10^5 MPa

⁽¹⁾ With $L_g > L$

The average and maximum values of the slip s [mm] shall be reported in the ETA.

2.2.3 High-cycle fatigue

Purpose of the assessment

The purpose of the assessment is the evaluation of the high-cycle fatigue behaviour of the sleeve when used to join rebars in static and dynamic applications.

2.2.3.1 Static application

Assessment method

The test shall be carried out according to EN ISO 15630-1, clause 8, with the following modifications:

- The free length of the specimen shall be chosen as described in clause 2.2.
- The test shall be performed with an upper stress level (σ_{max}) equal to $0.6 \cdot R_{e,nom}$.
- The temperature of the testing laboratory shall be equal to $23^\circ\text{C} \pm 2^\circ\text{C}$.
- The frequency shall be in the range between 1 Hz and 200 Hz.

The test consists of subjecting the specimen to an axial tensile stress that varies cyclically according to a sinusoidal waveform with constant frequency in the elastic range (Figure 2.2.3-1).

If the specimen fails near the grips of the testing machine, and the sleeve is still intact, the test may be continued after re-gripping the specimen with the same stress range, if the minimum free length is still available.

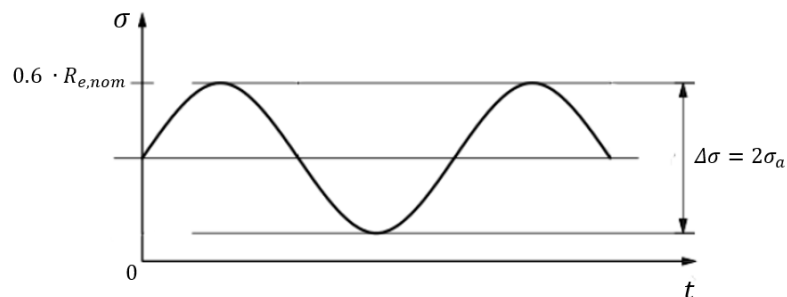

Figure 2.2.3-1 - Load cycle diagram for the high-cycle fatigue test

The test shall be carried out until the failure of the specimen or 3 million load cycles are reached.

The stress range shall be equal to $2\sigma_a = 60$ MPa.

For the reinforcing bars, the value of f_R has to be chosen as described in clause 2.2.

The rib spacing and the rib height of the reinforcing bars shall be reported in the ETA.

Minimum 3 valid tests shall be performed.

Expression of results

The minimum value of the number of cycles N , reached in the tests, shall be reported in the ETA.

2.2.3.2 Dynamic application

Assessment method

The test shall be carried out according to EN ISO 15630-1, clause 8, with the following modifications:

- The free length of the specimen shall be chosen as described in clause 2.2.
- The test shall be performed with an upper stress level (σ_{max}) equal to $0.6 \cdot R_{e, nom}$.
- The temperature of the testing laboratory shall be equal to $23^{\circ}\text{C} \pm 2^{\circ}\text{C}$.
- The frequency shall be in the range between 1 Hz and 200 Hz.

The test consists of subjecting the specimen to an axial tensile stress that varies cyclically according to a sinusoidal waveform with constant frequency in the elastic range (Figure 2.2.3-1).

If the specimen fails near the grips of the testing machine, and the sleeve is still intact, the test may be continued after re-gripping the specimen with the same stress range, if the minimum free length is still available.

The fatigue resistance of the sleeve is represented by the S-N curve. The S-N curve shall be determined by linear regression with 10% quantile. The S-N curve for the mechanical splice is the lower limit of the 10% quantile.

The test shall be performed at minimum 4 stress ranges with σ_{max} equal to $0.6 \cdot R_{e, nom}$. The stress ranges shall be selected such that the slope of the two lines forming the S-N curve can be obtained (Figure 2.2.3-2).

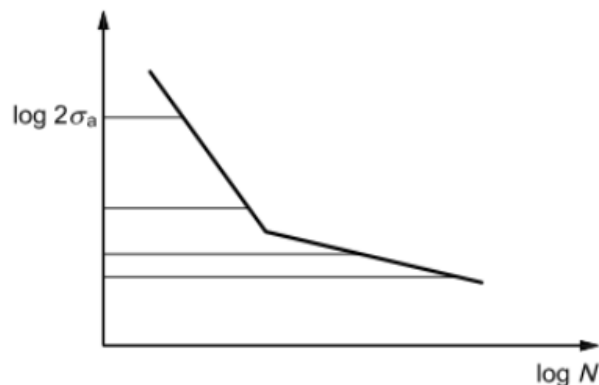

Figure 2.2.3-2: Typical form of an S-N diagram

In accordance with Table 6.3N of EN 1992-1-1, the resisting stress range at N^* (see Figure 2.2.3-3) for splicing devices is defined and the slopes of the two lines forming the S-N curve are respectively k_1 and k_2 .

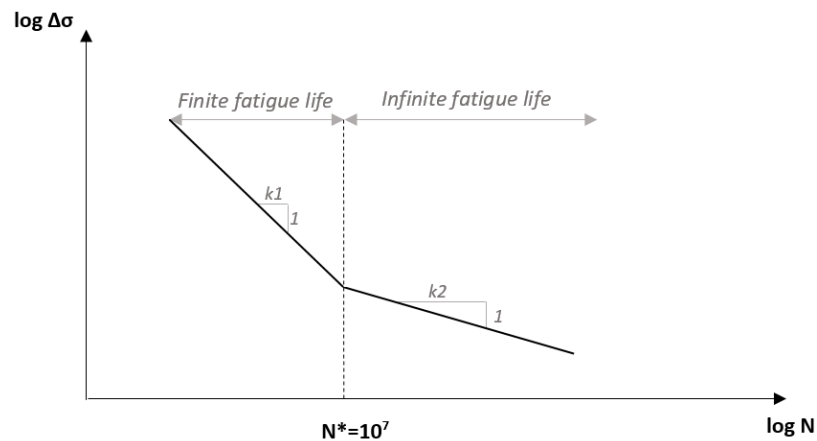

Figure 2.2.3-3: Definition of the slope of the two lines forming the S-N curve.

The four stress ranges, necessary to determine the slopes (k_1 and k_2) of the two lines forming the S-N curve, shall be equal to 20 MPa and 30 MPa, for the infinite fatigue life range, and 60 MPa and 95 MPa, for the finite fatigue life range.

To reduce the number of the tests, it is possible to use only the stress range equal to 60 MPa and 95 MPa, for the finite fatigue life, in order to determine k_1 . In this case, if the determined stress exponent k_1 is less than the exponent according to Table 6.3N of EN 1992-1-1, the stress exponent k_2 shall be calculated as $k_2 = 2k_1 - 1$. If the determined stress exponent k_1 is greater than the exponent according to Table 6.3N of EN 1992-1-1, the stress exponent k_2 shall be equal to the value reported in Table 6.3N of EN 1992-1-1.

For the reinforcing bars, the value of f_R has to be chosen as described in clause 2.2.

The rib spacing and the rib height of the reinforcing bars shall be reported in the ETA.

It is necessary to perform minimum 6 tests for each stress range.

Expression of results

The S-N curve in graphical and tabular form and the corresponding value of k_1 and k_2 shall be reported in the ETA.

2.2.4 Low-cycle fatigue: Alternating tension and compression test of high stresses in the mechanical splice

Purpose of the assessment

The purpose of the assessment is the evaluation of the low-cycle fatigue behaviour in alternating tension and compression test of high stresses in the mechanical splice.

Assessment method

The test shall be performed as described in ISO 15835-2, clause 5.6, with the following modifications on the loading sequence to be applied:

- perform the loading sequence according to “Stage 1” in ISO 15835-2, clause 5.6;
- load the test specimens to failure, under load control.

For the reinforcing bars, the value of f_R has to be chosen as described in clause 2.2.

The rib spacing and the rib height of the reinforcing bars shall be reported in the ETA.

Minimum 3 tests shall be performed.

Expression of results

The average and maximum values of the residual deformation after 20 cycles U_{20} [mm] and the average, characteristic and minimum values of the ultimate strength $\sigma_{f,u}$ [MPa] shall be reported in the ETA. The nominal tensile strength value of the unspliced reinforcing bar used for the test shall be reported in the ETA.

The ultimate strength $\sigma_{f,u}$ [MPa] shall be assessed on the basis of the nominal section of the bar S_n [mm²].

The characteristic value will be determined, by using the appropriate value of k_n for unknown V_x reported in EN 1990, Annex D, Table D1.

2.2.5 Low-cycle fatigue: Alternating tension and compression test of large strains in the mechanical splice

Purpose of the assessment

The purpose of the assessment is the evaluation of the low-cycle fatigue behaviour in alternating tension and compression test of large strains in the mechanical splice.

Assessment method

The test shall be performed as described in ISO 15835-2, clause 5.6, with the following modifications on the loading sequence to be applied (see Figure 2.2.5-1):

- perform the loading sequence according to “Stage 2” of ISO 15835-2, clause 5.6;
- perform the loading sequence according to “Stage 3” of ISO 15835-2, clause 5.6;
- load the test specimens to failure, under load control.

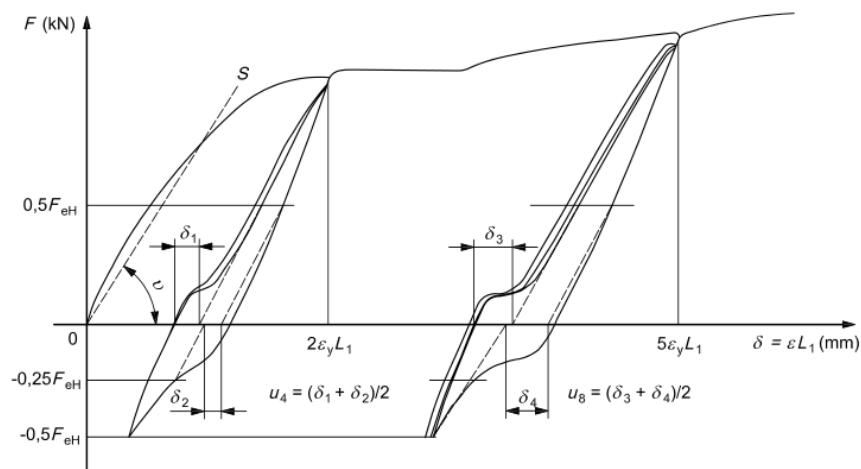

Figure 2.2.5-1: Loading sequence for low-cycle fatigue: alternating tension and compression test of large strains in the mechanical splice

For the reinforcing bars, the value of f_R has to be chosen as described in clause 2.2.

The rib spacing and the rib height of the reinforcing bars shall be reported in the ETA.

Minimum 3 tests shall be performed.

Expression of results

The test is carried out to determine the residual deformation after 4 cycles U_4 [mm], the residual deformation after 8 cycles U_8 [mm] and the ultimate strength $\sigma_{f,u}$ [MPa].

The residual deformations U_4 and U_8 (see Figure 2.2.5-1) shall be calculated as:

$$U_4 = \frac{\delta_1 + \delta_2}{2}; U_8 = \frac{\delta_3 + \delta_4}{2}$$

Where:

- δ_1 : elongation value represented by the distance between two crossing points on the horizontal axis, which are intersected with the parallel lines of S set from the level of loading of $0.5F_{eH}$ and from the level of reverse loading of $-0.25F_{eH}$ after alternative loading four times by twice the yield strain ε_y (strain at nominal yield strength).
- δ_2 : elongation value represented by the distance between two crossing points on the horizontal axis, which are intersected with the parallel lines of S set from the level of unloading stress $0.5F_{eH}$ and from the level of reverse unloading stress $-0.25F_{eH}$ after alternative loading four times by twice the yield strain ε_y (strain at nominal yield strength).
- δ_3 and δ_4 : elongation values obtained by the same method as δ_1 and δ_2 after alternative loading four times by five times the yield strain ε_y (strain at nominal yield strength).
- $S = \frac{E_S S_n}{L_1}$;
- $E_S = 2 * 10^5 \text{ MPa}$;
- S_n : nominal cross section of the rebar;
- L_1 : as defined in clause 2.2 of this EAD;
- $F_{eH} = S_n * R_{eH,spec}$;
- $R_{eH,spec}$: specified characteristic (or nominal) yield strength value of the reinforcing bar.

The average and maximum values of the residual deformation after 4 cycles U_4 [mm] and the residual deformation after 8 cycles U_8 [mm] and the average, characteristic and minimum values of the ultimate strength $\sigma_{f,u}$ [MPa] shall be reported in the ETA. The nominal tensile strength value of the unspliced reinforcing bar used for the test shall be reported in the ETA.

The ultimate strength $\sigma_{f,u}$ [MPa] shall be evaluated on the basis of the nominal section of the bar S_n [mm²].

The characteristic value will be determined by using the appropriate value of k_n for unknown V_x reported in EN 1990, Annex D, Table D1.

2.2.6 Reaction to fire

The sleeve is considered to satisfy the requirements for performance class A1 of the characteristic reaction to fire in accordance with the Commission Decision 96/603/EC, as amended by Commission Decisions 2000/605/EC and 2003/424/EC, without the need for testing on the basis of it fulfilling the conditions set out in that Decision and its intended use being covered by that Decision.

Therefore, the performance class of the product is A1.

3 ASSESSMENT AND VERIFICATION OF CONSTANCY OF PERFORMANCE

3.1 System(s) of assessment and verification of constancy of performance to be applied

For the products covered by this EAD the applicable European legal act is Commission Decision 2000/606/EC.

The system is 1+.

3.2 Tasks of the manufacturer

The cornerstones of the actions to be undertaken by the manufacturer of the product in the procedure of assessment and verification of constancy of performance are laid down in Table 3.2.1.

Table 3.2.1 Control plan for the manufacturer; cornerstones

No	Subject/type of control	Test or control method	Criteria, if any	Minimum number of samples	Minimum frequency of control
Factory production control (FPC) [including testing of samples taken at the factory in accordance with a prescribed test plan]					
1	Materials	Supplier data check	According to Control Plan	-	Every delivery
2	Aspect	Visual check	According to Control Plan	-	100% batch ⁽¹⁾
3	Dimensions and tolerances	Calliper ⁽²⁾	According to Control Plan	1 per size of the sleeve and per type of sleeve ⁽³⁾	Each batch ⁽¹⁾ , at the beginning and at the end of the process.
4	Tensile strength	As defined in clause 2.2.1 of EAD	According to Control Plan	1 per size of the sleeve and per type of rebar ⁽⁴⁾	Every 1000 pieces of each batch ⁽¹⁾⁽⁵⁾
⁽¹⁾ Batch means a continuous production of the same type and size coming from the same casting. ⁽²⁾ Reliably within ± 0.1 mm. ⁽³⁾ Type of sleeve in terms of steel (yield strength) and in terms of type of lateral compression (by nails and by metal tablets). ⁽⁴⁾ Type of rebar in terms of straight length and de-coiled rebar. The value of f_R of rebar shall be chosen in the range reported in clause 2.2 of this EAD. ⁽⁵⁾ If the batch consists of a quantity less than 1000 pieces, the check shall be carried out on a single sample.					

3.3 Tasks of the notified body

The cornerstones of the actions to be undertaken by the notified body of the product in the procedure of assessment and verification of constancy of performance are laid down in Table 3.3.1.

Table 3.3.1 Control plan for the notified body; cornerstones

No	Subject/type of control	Test or control method	Criteria, if any	Minimum number of samples	Minimum frequency of control
Initial inspection of the manufacturing plant and of factory production control					
1	The Notified Body will ascertain that the factory production control with the staff and equipment are suitable to ensure a continuous and orderly manufacturing of the sleeve.	Verification of the complete FPC as described in the control plan agreed between the TAB and the manufacturer.	According to Control Plan	According to Control Plan	When starting the production or a new production line
Continuous surveillance, assessment and evaluation of factory production control					
2	The Notified Body will ascertain that the system of factory production control and the specified manufacturing process are maintained taking account of the control plan.	Verification of the controls carried out by the manufacturer as described in the control plan agreed between the TAB and the manufacturer with reference to the raw materials, to the process and to the product as indicated in Table 3.2.1	According to Control Plan	According to Control Plan	Once a year
Audit-testing of samples taken by the notified product certification body at the manufacturing plant or at the manufacturer's storage facilities					
3	Slip	As defined in clause 2.2.2 of EAD	According to Control Plan	1 for one size of the sleeve ⁽¹⁾ per type of sleeve ⁽²⁾ and per type of rebar ⁽³⁾	Once a year
4	Tensile strength	As defined in clause 2.2.1 of EAD	According to Control Plan	3 for one size of the sleeve ⁽¹⁾ per type of sleeve ⁽²⁾ and per type of rebar ⁽³⁾	Once a year
5	High-cycle fatigue	As defined in clause 2.2.3 of EAD	According to Control Plan	3 for one size of the sleeve ⁽¹⁾ per type of sleeve ⁽²⁾ and per type of rebar ⁽³⁾	Once a year
6	Low-cycle fatigue: Alternating tension and compression test of high stresses	As defined in clause 2.2.4 of EAD	According to Control Plan	1 for one size of the sleeve ⁽¹⁾ per type of sleeve ⁽²⁾ and per type of rebar ⁽³⁾	Once a year
7	Low-cycle fatigue: Alternating tension and compression test of large strains	As defined in clause 2.2.5 of EAD	According to Control Plan	1 for one size of the sleeve ⁽¹⁾ per type of sleeve ⁽²⁾ and per type of rebar ⁽³⁾	Once a year
8	Dimensions and tolerances	According to Control Plan	According to Control Plan	3 for one size of the sleeve ⁽¹⁾ per type of sleeve ⁽²⁾	Once a year
<p>⁽¹⁾ All sizes shall be tested within a period of 5 years.</p> <p>⁽²⁾ Type of sleeve in terms of steel (yield strength) and in terms of type of lateral compression (by nails and by metal tablets).</p> <p>⁽³⁾ Type of rebar in terms of straight length and de-coiled rebar. The value of f_R of rebar shall be chosen in the range reported in clause 2.2 of this EAD.</p>					

4 REFERENCE DOCUMENTS

EN 1990:2002+A1:2005+A1: 2005/AC:2010	Eurocode - Basis of structural design
EN 1992-1- 1:2004+A1:2014	Eurocode 2: Design of concrete structures - Part 1-1: General rules and rules for buildings
EN ISO 6892-1:2020	Metallic material – Tensile Testing – Part 1: Method of test at room temperature
EN ISO 9513:2012	Calibration of the extensometer systems used in uniaxial testing
EN ISO 15630-1:2019	Steel for the reinforcement and prestressing of concrete – Test Methods – Part 1: Reinforcing bars, wire rod and wire
ISO 15835-2:2018	Steels for the reinforcement of concrete – Reinforcement couplers for mechanical slices of bars – Part 2: Test methods