



EUROPEAN ASSESSMENT DOCUMENT

EAD 090020-00-0404

October 2016

KITS FOR EXTERNAL WALL CLADDINGS MADE OF AGGLOMERATED STONE

The reference title and language for this EAD is English. The applicable rules of copyright refer to the document elaborated in and published by EOTA.

This European Assessment Document (EAD) has been developed taking into account up-to-date technical and scientific knowledge at the time of issue and is published in accordance with the relevant provisions of Regulation (EU) No 305/2011 as a basis for the preparation and issuing of European Technical Assessments (ETA).

Contents

1	Scope of the EAD	5
1.1	Description of the construction product	5
1.2	Information on the intended use(s) of the construction product	6
1.2.1	Intended use(s)	6
1.2.2	Working life/Durability	6
1.3	Specific terms used in this EAD (if necessary in addition to the definitions in CPR, Art 2)	7
1.3.1	Cladding kit	7
1.3.2	Substrate	7
1.3.3	Subframe	7
1.3.4	Cladding element	7
1.3.5	Cladding fixing	7
1.3.6	Decorative coat	7
1.3.7	Air space	7
1.3.8	Ventilated air space	7
2	Essential characteristics and relevant assessment methods and criteria	8
2.1	Essential characteristics of the product	8
2.2	Methods and criteria for assessing the performance of the product in relation to essential characteristics of the product	9
2.2.1	Reaction to fire	9
2.2.2	Watertightness of joints (protection against driving rain)	9
2.2.3	Drainability	9
2.2.4	Wind load resistance	10
2.2.5	Resistance to vertical load	10
2.2.6	Impact resistance	10
2.2.7	Bending strength of cladding element	10
2.2.8	Resistance of grooved cladding element	11
2.2.9	Resistance of cladding fixing (horizontal and vertical load)	11
2.2.10	Resistance of profiles	11
2.2.11	Pull-through resistance of fixing from profile	11
2.2.12	Pull-out resistance of fixing from profile	11
2.2.13	Bracket resistance (horizontal and vertical load)	11
2.2.14	Dimensional stability by humidity of the cladding element	12
2.2.15	Linear thermal expansion coefficient of the cladding element	12
2.2.16	Freeze-thaw resistance of the cladding element	12
2.2.17	Thermal shock resistance of the cladding element	12
2.2.18	Corrosion of metal components	12
3	Assessment and verification of constancy of performance	13
3.1	System(s) of assessment and verification of constancy of performance to be applied	13
3.2	Tasks of the manufacturer	13
3.3	Tasks of the notified body	14
4	Reference documents	15
	ANNEX A – REACTION TO FIRE	16
	ANNEX B – MOUNTING AND FIXING PROVISIONS FOR THE SBI TEST	19
	ANNEX C – ADDITIONAL CRITERIA FOR WATERTIGHTNESS TESTS	22
	ANNEX D – WIND SUCTION AND PRESSURE LOAD TESTS	24

ANNEX E – RESISTANCE TO VERTICAL LOAD TEST..... 27

ANNEX F – IMPACT RESISTANCE TEST 28

ANNEX G – GROOVED CLADDING ELEMENT RESISTANCE TEST..... 31

ANNEX H – MECHANICAL RESISTANCE OF CLADDING FIXINGS 33

ANNEX I – PULL-THROUGH / PULL-OUT RESISTANCE TEST 35

ANNEX J – BRACKETS RESISTANCE (HORIZONTAL AND VERTICAL LOAD) TEST 38

1 SCOPE OF THE EAD

1.1 Description of the construction product

This EAD is applicable to the kits¹ composed by the following components:

1. Cladding elements made of agglomerated stone according to harmonized standard EN 15286. The cladding elements include a decorative coat on the external surface applied in the factory.
2. Cladding fixings made of aluminium alloy or stainless steel. Two types of cladding fixings are considered in this document:
 - Linear profiles for cladding elements with groove (see figure 1.1). One profile can support one or two cladding elements, and at least two profiles are needed to support one cladding element.
 - Punctual cladding fixings (e.g. clips, small rails, pins, clamps, hungs, etc.) for cladding elements with or without groove (see figure 1.1 and figure 1.2 respectively). One cladding fixing can support two or four cladding elements, and at least four cladding fixings are needed to support one cladding element.

Both types of cladding fixings can be positioned on the subframe profile or directly on the supporting structure (substrate).

3. Subframe components made of aluminium alloy, galvanized steel or stainless steel. The subframes defined in this EAD consist of the following components:
 - Vertical profiles.
 - Brackets for fastening the vertical profiles to the supporting structure (substrate).
 - Screws between the brackets and the vertical profiles and between the cladding fixings and the vertical profiles.

The technical description of the cladding elements, the cladding fixings and subframe components should be indicated in the ETA .

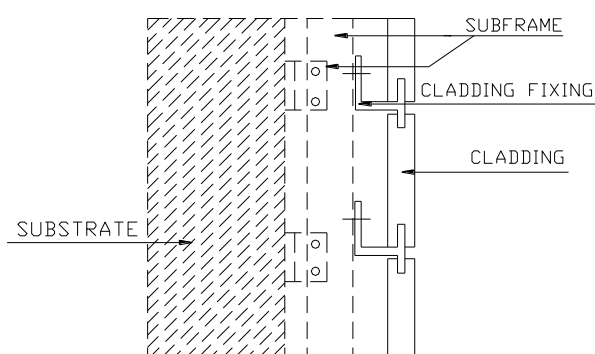

Figure 1.1: Cladding element with groove.

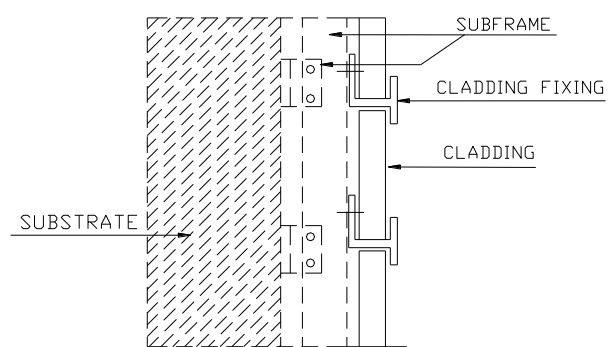

Figure 1.2: Cladding element without groove.

¹ Definition of "Kit" according to Art. 2 n° 2 of CPR. The components are assembled on site, and thus, become an "assembled cladding kit" when installed in the construction works.

The manufacturer can provide:

- a complete kit (cladding element, cladding fixings and subframe components),
- a minimum kit (cladding element and cladding fixings) or,
- the cladding element alone (without cladding fixings or subframe), in this case, an ETA can be issued in accordance with this EAD, only if the other components of the kit (e.g. cladding fixings) are available on the market and specified in the ETA by the description of dimensions, material and performances of components. The manufacturer and trading reference of fixings may be indicated. In this case, the assessment shall be done with the specified cladding fixings and therefore, performances stated in the ETA applies only for the configuration as used in ETA process.

The product is not fully covered by ETAG 034 (April 2012). Cladding elements made of agglomerated stone are excluded in the scope of the ETAG 034. The product is not covered by EN 15286 because this standard does not cover kits or other mechanical fixings different than dowel holes.

Concerning product packaging, transport, storage, maintenance, replacement and repair it is the responsibility of the manufacturer to undertake the appropriate measures and to advise his clients on the transport, storage, maintenance, replacement and repair of the product as he considers necessary.

It is assumed that the product will be installed according to the manufacturer's instructions or (in absence of such instructions) according to the usual practice of the building professionals.

Relevant manufacturer's stipulations having influence on the performance of the product covered by this European Assessment Document shall be considered for the determination of the performance and detailed in the ETA.

1.2 Information on the intended use(s) of the construction product

1.2.1 Intended use(s)

This EAD covers the intended use of external wall claddings in ventilated façades (rainscreens).

Cladding kits are fixed to external vertical walls made of masonry (clay, concrete or stone), concrete (cast on site or as prefabricated panels), timber or metal frame in new or existing buildings (retrofit).

1.2.2 Working life/Durability

The assessment methods included or referred to in this EAD have been written based on the manufacturer's request to take into account a working life of the cladding kit made of agglomerated stone for the intended use of 25 years when installed in the works. These provisions are based upon the current state of the art and the available knowledge and experience.

When assessing the product the intended use as foreseen by the manufacturer shall be taken into account. The real working life may be, in normal use conditions, considerably longer without major degradation affecting the basic requirements for works².

The indications given as to the working life of the construction product cannot be interpreted as a guarantee neither given by the product manufacturer or his representative nor by EOTA when drafting this EAD nor by the Technical Assessment Body issuing an ETA based on this EAD, but are regarded only as a means for expressing the expected economically reasonable working life of the product.

² The real working life of a product incorporated in a specific works depends on the environmental conditions to which that works is subject, as well as on the particular conditions of the design, execution, use and maintenance of that works. Therefore, it cannot be excluded that in certain cases the real working life of the product may also be shorter than referred to above.

1.3 Specific terms used in this EAD (if necessary in addition to the definitions in CPR, Art 2)

1.3.1 Cladding kit

A cladding kit is a specific kit composed by an agglomerated stone cladding element, its cladding fixings and optionally a subframe, which is used as rainscreen of external walls.

1.3.2 Substrate

The term "substrate" refers to a wall, which in itself already meets the necessary airtightness and mechanical strength requirements (resistance to static and dynamic loads), as well as a relevant watertightness and water vapour resistance. The substrate walls can be made of masonry (clay, any kind of concrete or stone), concrete (cast on site or as prefabricated panels), timber or metal frame.

1.3.3 Subframe

An intermediate assembly of vertical and/or horizontal metal profiles and brackets (including the fixings between the brackets and the profiles) located between the cladding element and the substrate.

1.3.4 Cladding element

Panel made of agglomerated stone (according to the specific terms indicated in EN 15286 and EN 14618) applied at the external face of an external wall.

1.3.5 Cladding fixing

Profiles, brackets, screws/anchors, nails, rivets or any special fixing devices used to secure the cladding element to the subframe.

1.3.6 Decorative coat

Factory applied coat which generally contributes to the aesthetic finishing of the cladding element and can also provide supplementary protection against weathering.

1.3.7 Air space

It is the space between the cladding and the insulation layer or the substrate accordingly.

1.3.8 Ventilated air space

A layer of air between the substrate or insulation layer and cladding elements connected to the external environment permitting the dry-out of the water that may be found in this space due to condensations or rain penetration and the water vapour diffusion from the internal side of the wall.

External wall claddings are considered as ventilated when the following criteria are fulfilled:

- The distance between the cladding elements and the insulation layer or the substrate accordingly (ventilation air space) amounts to at least 20 mm. This air space may be reduced locally to 5 to 10 mm depending on the cladding and the subframe, provided that it is verified that it does not affect the draining and/or ventilation function,
- Ventilation openings are envisaged, as a minimum, at the building base point and at the roof edge with cross-sections of at least 50 cm² per linear metre.

2 ESSENTIAL CHARACTERISTICS AND RELEVANT ASSESSMENT METHODS AND CRITERIA

2.1 Essential characteristics of the product

Table 1 shows how the performance of cladding kit is assessed in relation to the essential characteristics.

Table 1 Essential characteristics of the product and methods and criteria for assessing the performance of the product in relation to those essential characteristics

No	Essential characteristic	Assessment method	Type of expression of product performance
Basic Works Requirement 2: Safety in case of fire			
1	Reaction to fire	2.2.1	Class
Basic Works Requirement 3: Hygiene, health and the environment			
2	Watertightness of joints (protection against driving rain)	2.2.2	Description (for open joints) Level (for closed joints)
3	Drainability	2.2.3	Description
Basic Works Requirement 4: Safety and accessibility in use			
4	Wind load resistance	2.2.4	Level
5	Resistance to vertical load (iv)	2.2.5	Level
6	Impact resistance	2.2.6	Level
7	Bending strength of cladding element	2.2.7	Level
8	Resistance of grooved cladding element (i)	2.2.8	Level
9	Resistance of cladding fixing (horizontal and vertical load) (ii) (iv)	2.2.9	Level
10	Resistance of profiles (iv)	2.2.10	Description
11	Pull-through resistance of fixing from profile (iii) (iv)	2.2.11	Level
12	Pull-out resistance of fixing from profile (v)	2.2.12	Level
13	Bracket resistance (horizontal and vertical load) (v)	2.2.13	Level
14	Dimensional stability by humidity of the cladding element	2.2.14	Level
15	Linear thermal expansion coefficient of the cladding element	2.2.15	Level
16	Freeze-thaw resistance of the cladding element	2.2.16	Level
17	Thermal shock resistance of the cladding element	2.2.17	Level
18	Corrosion of metal components (iv)	2.2.18	Description
(i) Only for cladding elements with groove. (ii) Only for punctual cladding fixings (e.g. clips, small rails, pins, clamps, hungs, etc.). (iii) Only for linear cladding fixings (e.g. rail profiles). (iv) Only for complete kits or minimum kits provided by the manufacturer (see section 1.1). (v) Only for complete kits provided by the manufacturer (see section 1.1).			

2.2 Methods and criteria for assessing the performance of the product in relation to essential characteristics of the product

2.2.1 Reaction to fire

Reaction to fire of the whole kit shall be assessed by considering the reaction to fire of the components (cladding element, cladding fixings and subframe components), in order to be classified according to Commission Delegated Regulation (EU) 2016/364 and EN 13501-1.

Reaction to fire of the cladding element shall be assessed according to EN 15286. When relevant, the cladding element shall be tested, using the test method(s) relevant for the corresponding reaction to fire class, in order to be classified according to Commission Delegated Regulation (EU) 2016/364 and EN 13501-1.

Criteria indicated in Annex A shall be taken into account. Associated mounting and fixing rules for the SBI test shall be in accordance with Annex B.

The metal cladding fixings and subframe components are considered to satisfy the requirements for performance class A1 of the characteristic reaction to fire, in accordance with the provisions of EC Decision 96/603/EC (as amended) without the need for testing on the basis of its listing in that Decision.

When relevant, reaction to fire of the rear side of the cladding element may also be tested using the test method(s) relevant for the corresponding reaction to fire class, in order to be classified according to Commission Delegated Regulation (EU) 2016/364 and EN 13501-1.

2.2.2 Watertightness of joints (protection against driving rain)

The assessment of watertightness of joints is intended to determine two requirements of the cladding kit:

- Water running down the wall shall not reach the inside face of the wall.
- Materials likely to be adversely affected by water (fixings subject to corrosion, adhesives, etc.) shall not become damp.

Cladding kits with open joints shall be described as “not watertight”³.

Cladding kits with close joints contribute to the watertightness of the wall. In this case, the watertightness of the cladding kit shall be determined by testing according to EN 12865 Procedure A (see also Annex C). At least the worst case shall be tested (e.g. maximum number of joints).

The limit level of pressure (e.g. just before water penetration) shall be given in the ETA.

Additionally, the ETA should include the relevant design details provided by the manufacturer, regarding the connections of the cladding kit with the roof edge, base edge and openings (windows or doors).

2.2.3 Drainability

The assessment of drainability is intended to determine whether water which penetrates in the air space or condensation water is drained out of the installed cladding kit without accumulation or moisture damage or leakage into the substrate or the cladding kit.

This assessment shall be carried out by description of the relevant design details provided by the manufacturer, regarding the cladding fixings geometry and the connections of the cladding kit with the base edge, openings (windows or doors). These design details should be included in the ETA.

³ When the joints are not watertight, the first layer behind ventilated air space (e.g. insulation layer) should be composed by materials with low water absorption (e.g. insulation products made of MW acc. to EN 13162, EPS acc. to EN 13163, XPS acc. to EN 13164, PUR acc. to EN 13165 and PF acc. to EN 13166), according to the national regulations in force.

2.2.4 Wind load resistance

The wind load resistance (suction and/or pressure) of assembled systems shall be carried out by calculation taking into account the mechanical resistances of the kit components (cladding elements, cladding fixings and subframe components) obtained from sections 2.2.7 to 2.2.13.

At least the worst case (the mechanically weakest case) or the more representative case of the assembled system shall be considered.

Relevant elasticity and resistance equations and relevant standards (e.g. EN 1999-1-1 for aluminium) should be considered for the calculation (at ultimate and serviceability limit states).

At least for one assembled system, the calculated result shall be contrasted by testing according to the method indicated in Annex D.

The assessment shall be based on the mechanical characteristics of the components (see sections 2.2.7 to 2.2.13) taking into account the results of the wind suction and/or pressure tests. In this case, if the test results obtained do not confirm the results obtained by mechanical tests of the kit components, at least two other test specimens have to be tested or the mechanical resistance of the kit components shall be corrected accordingly.

The wind load resistance for the cladding kit assembled systems shall be indicated.

2.2.5 Resistance to vertical load

The vertical load resistance of assembled systems shall be carried out by calculation taking into account the mechanical resistances of the kit components (cladding fixings and subframe components) obtained from sections 2.2.9 & 2.2.13.

At least the worst case (the mechanically weakest case) or the more representative case of the assembled system shall be considered.

Relevant elasticity and resistance equations and relevant standards (e.g. EN 1999-1-1 for aluminium) should be considered for the calculation (at ultimate and serviceability limit states).

At least for one assembled system, the calculated result shall be contrasted by testing according to the method indicated in Annex E.

The assessment shall be based on the mechanical characteristics of the components (see sections 2.2.9 & 2.2.13) taking into account, when relevant, the results of the vertical load resistance test. In this case, if the test results obtained do not confirm the results obtained by mechanical tests of the kit components, the mechanical resistance of the kit components shall be corrected accordingly.

2.2.6 Impact resistance

The external impact resistance shall be tested according to the method indicated in Annex F.

The hard body and soft body impact resistance shall be indicated.

Additionally, the degree of exposure according the use categories defined in the table F.2 of Annex F can be described.

2.2.7 Bending strength of cladding element

The bending strength of the agglomerated stone cladding element shall be determined according to the harmonized standard EN 15286. Test according to EN 14617-2.

The values shall cover the range of density and thickness of the cladding element.

2.2.8 Resistance of grooved cladding element

This characteristic is only relevant for cladding elements with groove.

The grooved cladding element resistance shall be tested according to the method indicated in Annex G.

At least the worst case (the mechanically weakest case) shall be tested.

The mean value and the characteristic value according to section G.3 of Annex G shall be indicated.

The values shall cover the range of density and thickness of the cladding element.

2.2.9 Resistance of cladding fixing (horizontal and vertical load)

In the case of punctual cladding fixings (e.g. clips, small rails, pins, clamps, hungs, etc.), the resistance of cladding fixing (horizontal and vertical load) shall be tested according to the method indicated Annex H.

At least the worst case (the mechanically weakest case) shall be tested.

In the case of punctual cladding fixings, the mean value and the characteristic value according to section H.5 of Annex H shall be indicated.

In the case of linear cladding fixings (profiles), see section 2.2.10.

2.2.10 Resistance of profiles

The following characteristics shall be described:

- Form and dimensions of the profile section according to relevant standards (e.g. EN 755-9 for aluminium).
- Inertia of the profile section according to the relevant standards (e.g. EN 1999-1-1 for aluminium).
- Minimum elastic limit of the material of the profile according to the relevant standards calculated according to the relevant standards (e.g. EN 755-2 for aluminium).
- Maximum deflection admitted by the manufacturer (e.g. L/200).

2.2.11 Pull-through resistance of fixing from profile

The fixing pull-through resistance on horizontal profiles used as cladding fixings shall be tested according to the method indicated in Annex I.

At least the worst case (the mechanically weakest case) shall be tested.

The mean value and the characteristic value according to section I.5 of Annex I shall be indicated.

2.2.12 Pull-out resistance of fixing from profile

The fixing pull-out resistance on relevant profiles of the subframe (e.g. vertical profiles) shall be tested according to the method indicated in Annex I.

At least the worst case (the mechanically weakest case) shall be tested.

The mean value and the characteristic value according to section I.5 of Annex I shall be indicated.

2.2.13 Bracket resistance (horizontal and vertical load)

The bracket load bearing capacity and deformation under loading (horizontal and vertical load) shall be tested according to the method indicated in Annex J.

At least the worst case (the mechanically weakest case) shall be tested.

The mean value and the characteristic value according to section J.6 of Annex J shall be indicated.

When it is possible, calculation according to relevant standards (e.g. EN 1999-1-1 for aluminium) can be carried out provided that this calculation is contrasted by testing according to the method indicated in Annex J.

2.2.14 Dimensional stability by humidity of the cladding element

The moisture content and length changes of the agglomerated stone cladding element associated with changes in relative humidity shall be determined according to EN 318.

The values shall cover the range of density of the cladding element.

2.2.15 Linear thermal expansion coefficient of the cladding element

The linear thermal expansion coefficient of the agglomerated stone cladding element shall be determined according to the harmonized standard EN 15286. Test according to EN 14617-11.

The values shall cover the range of density of the cladding element.

2.2.16 Freeze-thaw resistance of the cladding element

The freeze-thaw resistance of the agglomerated stone cladding element shall be determined according to the harmonized standard EN 15286. Test according to EN 14617-5.

The values shall cover the range of density of the cladding element.

2.2.17 Thermal shock resistance of the cladding element

The thermal shock resistance of the agglomerated stone cladding element shall be determined according to the harmonized standard EN 15286. Test according to EN 14617-6.

The values shall cover the range of density of the cladding element.

2.2.18 Corrosion of metal components

The corrosion protection of the cladding fixings and subframe components shall be described according to the appropriate EN standard (e.g. EN 10346 for continuously hot-dip coated steels).

The choice of steel, aluminium and stainless steel grade shall be described according to the appropriate EN standards (e.g. EN 10346 for continuously hot-dip coated steel, EN 755 and EN 1999-1-1 for aluminium alloys, EN 10088 for stainless steels).

The steel or aluminium grade and the respective corrosion protection shall be described in function of the field of application and the corrosivity of atmospheres defined in EN ISO 9223 (e.g. marine atmosphere, industrial atmosphere, etc.). In particularly aggressive atmospheres with extreme chemical pollution (e.g. desulphurization plants, chloride atmosphere), special measures of corrosion protection shall be foreseen.

If necessary, the performance deterioration caused by corrosion should also be described.

3 ASSESSMENT AND VERIFICATION OF CONSTANCY OF PERFORMANCE

3.1 System(s) of assessment and verification of constancy of performance to be applied

For the products covered by this EAD the applicable European legal act is: Decision 2003/640/EC.

The system is: **2+**

In addition, with regard to e.g. reaction to fire for products covered by this EAD the applicable European legal act is: Decision 2003/640/EC.

The systems are: **1, 3 or 4**

3.2 Tasks of the manufacturer

The cornerstones of the actions to be undertaken by the manufacturer of the product in the procedure of assessment and verification of constancy of performance are laid down in Table 2.

Table 2 Control plan for the manufacturer; cornerstones

No	Subject/type of control	Test or control method	Criteria, if any	Minimum number of samples	Minimum frequency of control
Factory production control (FPC)					
1	Agglomerated stone cladding elements	Acc. to EN 15286	Acc. to Control Plan	Acc. to EN 15286	Acc. to EN 15286
	- Resistance of grooved cladding element	§2.2.8		Acc. to Control Plan	At least once per year
2	Cladding fixings and subframe components:				
	- Material	Supplier certificates	Acc. to Control Plan	Testing is not required	Each delivery
	- Geometry (form and dimensions)	Supplier certificates	Acc. to Control Plan	Testing is not required	Each delivery
		Measuring or visual check	Acc. to Control Plan	Acc. to Control Plan	Acc. Control Plan
- Mechanical characteristics	§2.2.9 §2.2.11 §2.2.13	Acc. to Control Plan	Acc. to Control Plan	At least once each 5 years	

3.3 Tasks of the notified body

The cornerstones of the actions to be undertaken by the notified body in the procedure of assessment and verification of constancy of performance for cladding kit of agglomerated stone are laid down in Table 3.

Table 3 Control plan for the notified body; cornerstones

No	Subject/type of control	Test or control method	Criteria, if any	Minimum number of samples	Minimum frequency of control
Initial inspection of the manufacturing plant and of factory production control					
1	The notified body shall verify the ability of the manufacturer for a continuous and orderly control of the product according to the European Technical Assessment. In particular the following items shall be appropriately considered <ul style="list-style-type: none"> - personnel and equipment - the suitability of the factory production control established by the manufacturer - full implementation of the prescribed Control Plan 				---
Continuous surveillance, assessment and evaluation of factory production control					
2	The notified body shall verify that <ul style="list-style-type: none"> - the manufacturing process of the agglomerated stone cladding elements - the system of factory production control - the implementation of the prescribed Control Plan are maintained.				Once per year

4 REFERENCE DOCUMENTS

As far as no edition date is given in the list of standards thereafter, the standard in its current version at the time of issuing the European Technical Assessment, is of relevance.

EN 10088-1	Stainless steels - Part 1: List of stainless steels.
EN 10088-2	Stainless steels - Part 2: Technical delivery conditions for sheet/plate and strip of corrosion resisting steels for general purposes.
EN 10088-4	Stainless steels - Part 4: Technical delivery conditions for sheet/plate and strip of corrosion resisting steels for construction purposes.
EN 10346	Continuously hot-dip coated steel flat products - Technical delivery conditions.
EN 12865	Hygrothermal performance of building components and building elements - Determination of the resistance of external wall systems to driving rain under pulsating air pressure.
EN 13238	Reaction to fire tests for building products - Conditioning procedures and general rules for selection of substrates.
EN 13501-1	Fire classification of construction products and building elements - Part 1: Classification using data from reaction to fire tests.
EN 13823	Reaction to fire tests for building products - Building products excluding floorings exposed to the thermal attack by a single burning item.
EN 14617-1	Agglomerated stone - Test methods - Part 1: Determination of apparent density and water absorption.
EN 14617-2	Agglomerated stone - Test methods - Part 2: Determination of flexural strength (bending).
EN 14617-5	Agglomerated stone - Test methods - Part 5: Determination of freeze and thaw resistance.
EN 14617-6	Agglomerated stone - Test methods - Part 6: Determination of thermal shock resistance.
EN 14617-11	Agglomerated stone - Test methods - Part 11: Determination of linear thermal expansion coefficient.
EN 14618	Agglomerated stone - Terminology and classification.
EN 15286	Agglomerated stone - Slabs and tiles for wall finishes (internal and external).
EN 1990	Eurocode - Basis of structural design.
EN 1999-1-1	Eurocode 9: Design of aluminium structures - Part 1-1: General structural rules.
EN 318	Wood based panels - Determination of dimensional changes associated with changes in relative humidity.
EN 755-1	Aluminium and aluminium alloys- Extruded rod/bar, tube and profiles - Part 1: Technical conditions for inspection and delivery.
EN 755-2	Aluminium and aluminium alloys - Extruded rod/bar, tube and profiles - Part 2: Mechanical properties.
EN 755-9	Aluminium and aluminium alloys - Extruded rod/bar, tube and profiles - Part 9: Profiles, tolerances on dimensions and form.
EN ISO 11925-2	Reaction to fire tests - Ignitability of products subjected to direct impingement of flame - Part 2: Single-flame source test (ISO 11925-2).
EN ISO 7500-1	Metallic materials - Verification of static uniaxial testing machines - Part 1: Tension/compression testing machines - Verification and calibration of the force-measuring system (ISO 7500-1).
EN ISO 9223	Corrosion of metals and alloys - Corrosivity of atmospheres - Classification, determination and estimation.

ANNEX A – REACTION TO FIRE

A.1 General

A.1.1 Principle

The determination of reaction to fire of the agglomerated stone cladding elements is based on testing of “the worst case” - the most critical configuration in sense of reaction to fire. According to the rules described further in the text, the classification obtained on the most critical configuration of the cladding element material is valid for all configurations of cladding element material stone having better performance in sense of reaction to fire.

For the particular parts of the cladding elements, the following principles apply:

- The cladding element material (agglomerated stone) and the decorative coat with the highest amount of organic content⁴ (if there are only differences in the amount of organic content but no difference in the organic component itself) or the highest PCS value (according to EN ISO 1716) of this organic component shall be tested.
- In addition, each cladding element material and decorative coat selected for testing according to the previous point shall have the lowest amount of flame retardants.

A.1.2 Physical properties influencing the reaction to fire behaviour

- Type of cladding element (composition, thickness, density).
- The organic content of the binder and of any organic additive; this can be checked by providing the formulation of the cladding element and decorative coat, by performing suitable identification tests or by determining the glow loss or net calorific value.
- Type and amount of flame retardant.
- Type of decorative coat (composition, thickness, mass per unit area).
- Type and nature of cladding fixings.

Note: Fire breaks are important for the behaviour of the whole facade cladding system and cannot be assessed on the basis of SBI-testing. The influence can only be observed during a large scale test. Therefore breaks are not included in the mounting and fixing rules for the SBI-test.

Although the rest of this annex applies the “worst case scenario” for deciding what to test, it is accepted that, where the manufacturer produces a range of cladding elements having different overall classifications, he may group these together into a number of different sub-groups (e.g. each sub-group corresponding to a different overall classification) with the ‘worst case scenario’ being identified for each sub-group.

Components of a cladding kit which are classified A1 without testing according to Decision 96/603/EC (as amended) do not need to be tested.

A.2 Testing according to EN ISO 1182

This test method is relevant for classes A1 and A2.

Using this test method, only the substantial components of the cladding kit need to be tested. ‘Substantial components’ are defined by thickness (≥ 1 mm) and/or mass per unit area (≥ 1 kg/m²).

Parameters relevant for this test method are:

⁴ The ETA holder is responsible for the information on organic content per unit area. If the information is not available, the PCS value shall be tested to decide about the worst case.

- Type of cladding element (composition, thickness, density).
- Type of decorative coat (composition, thickness, mass per unit area).

For these components, the principles specified in clause A.1 shall be applied.

A.3 Testing according to EN ISO 1716 (PCS value)

This test method is relevant for classes A1 and A2.

This test method shall be performed to all components of the cladding kit except for cases which are classified as A1 without testing.

Parameters relevant for this test method are: composition (when performing calculation of the PCS_s-value), density or mass per unit area and thickness. Mechanical fixings and ancillary materials which are not continuous but discrete components of cladding kit do not need to be considered for testing and for the calculation of the PCS_s.

It is not necessary to test a cladding element with different grain sizes if the organic content is the same as or lower than that of the tested cladding element.

A.4 Testing according to EN 13823 (SBI-test)

This test method is relevant for classes A2, B, C and D (in some cases also for A1).

Mounting and fixing provisions for the SBI-test for cladding kits are indicated in Annex B.

Parameters which are relevant for this test method:

- Type of cladding element (composition, thickness, density).
- Type of decorative coat (composition, thickness, mass per unit area).
- Amount of organic content.
- Amount of flame retardant, if any.

In principle, it is desirable to find the test specimen configuration that gives the worst case concerning the reaction to fire test results. In the test procedure according to EN 13823, values for the rate of heat release, total heat release, lateral flame spread, rate of smoke release, total smoke release and burning droplets are determined.

By testing one cladding element with one specific decorative coat representing a range of different coats, the following rules should be applied to discriminate the composition, which is able to represent a range of coats:

- The cladding element and the decorative coat, taking account of the permissible combination(s) allowed by the manufacturer, shall be determined in accordance with the principles specified in section A.1.
- The test specimen shall be prepared with the cladding element and the decorative coat with the highest organic content or PCS_s-value per unit area.
- The cladding elements with lowest and highest thickness / density have to be tested.

A.4.1 Direct application rules of test results

The test result is valid for:

- Cladding elements:
 - of the same type,

- the range between lowest and highest thickness / density,
 - with equal or lower organic content,
 - with equal or lower PCS_S-value per unit area,
 - with equal or higher content of the same type of flame retardants.
- Decorative coats:
- with lower thickness,
 - with equal or less organic content,
 - with equal or lower PCS_S-value per unit area,
 - with equal or greater content of the same type of flame retardants.

A.5 Testing according to EN ISO 11925-2

This test method is relevant for classes B, C, D and E.

Parameters which are relevant:

- Type of cladding element (composition, thickness, density).
- Type of decorative coat (composition, thickness, mass per unit area).
- Amount of organic content
- Amount of flame retardant, if any.

For cladding elements with covered edges, the specimens shall be prepared both with covered edges and edges without covering (cut edges).

The tests are performed with surface flaming of the front side and possibly edge flaming of the test specimen turned 90° according to the rules of standard EN ISO 11925-2.

Besides, the principles specified in clause A.1 shall be applied.

ANNEX B – MOUNTING AND FIXING PROVISIONS FOR THE SBI TEST

Considerations for cladding kits included in section A.4 of Annex A shall also be considered for SBI test.

The reaction to fire testing shall be given for the whole kit, in simulating its end-use conditions.

The testing standard EN 13823 gives a general description of the arrangement of the test specimen for SBI test, applicable to classes A2, B, C and D (in some cases also to A1).

This Annex describes specific provisions for cladding kits.

B.1 General information

As a function of the use of the kit, the specimen shall be installed on a substrate in accordance with standard EN 13238:

- Calcium silicate or fibre-cement board simulates a wall made of masonry or concrete,
- Non FR particle board simulates a wall made of timber frame,
- Steel sheet simulates a wall made of metal frame.

The frame is made from non fire-retardant treated timber, aluminium or steel.

All ancillary components which form part of the kit (e.g. breather membranes and cavity barriers) shall be included in a representative fashion in the test specimen.

An air space is always provided behind the cladding element in accordance with the manufacturer's instructions (minimum of 20 mm). The bottom and top edges of the specimen shall also remain opened.

If mineral wool insulation layer is planned in end-use situation of the kit, a 50 mm thick insulation product made of mineral wool according to EN 13162, with a density of 30 to 70 kg/m³, shall be installed between frame and substrate.

For other insulation materials, different conditions can be used for testing (e.g. maximum and/or minimum thicknesses, maximum and/or minimum density, unless proven otherwise).

The cladding elements are fixed to the frame. The cladding kit shall be installed with the cladding fixing density defined by the manufacturer as specified in the ETA.

When the kit presents a horizontal joint, it shall be tested with a horizontal joint in the long wing at a height of 500 mm from the bottom edge of the specimen and when the kit tested presents a vertical joint, it shall be tested with a vertical joint in the long wing at a distance of 200 mm from the corner line, in accordance with the Figure B.1. In the areas A, B, C, D and E, it is possible to have other vertical and/or horizontal joints between cladding elements, if their size is not big enough.

In the internal vertical angle, no profile shall be used and the cladding elements create a vertical closed joint.

Note: Asymmetrically composed cladding products shall be tested in such a way that the rear of the product is exposed to the flame.

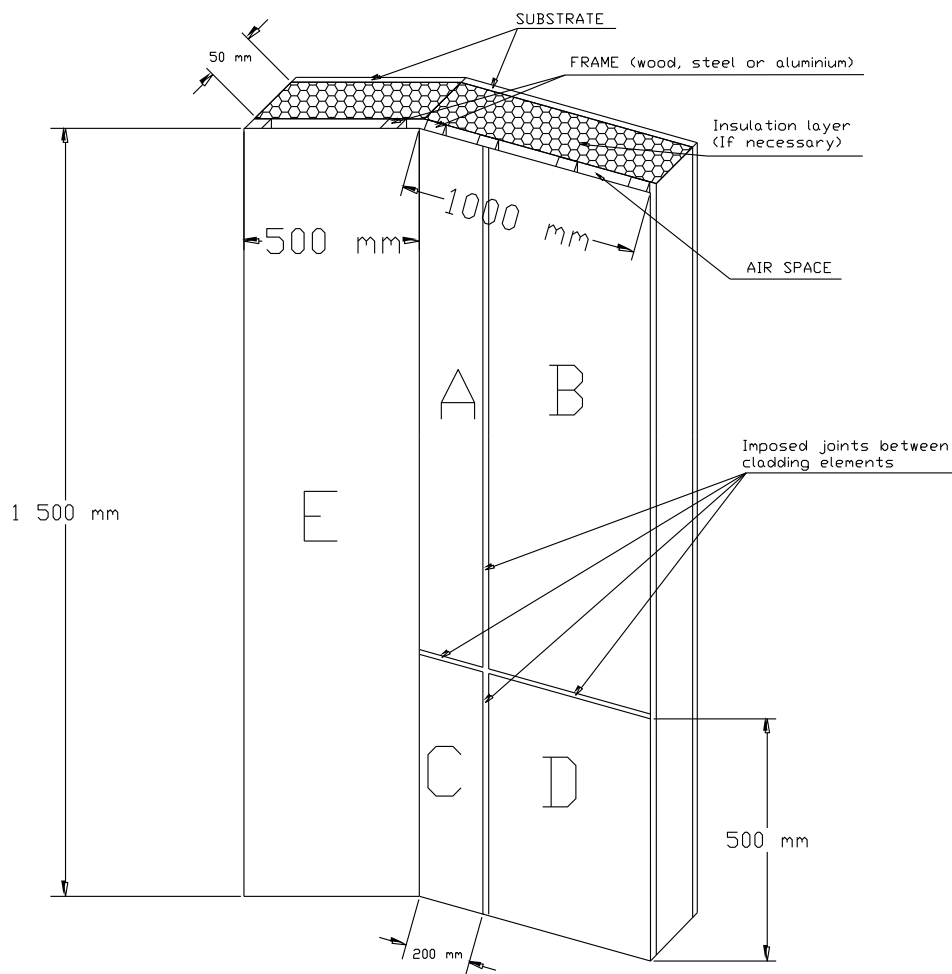

Figure B.1: Example of SBI test installation.

Note: The two wings are perpendicular.

B.2 Specific information

The kits are tested in a limited number of configurations to cover the influence of the parameters indicated in section A.4 of Annex A.

The cladding elements can be cut to size as shown in Figures B.2.

The cladding fixing and subframe shall be fixed to the substrate through fixings adapted to the type and material of the substrate.

B.3 Extension of results

Results of SBI test shall be extended according to section A.4.1 of Annex A.

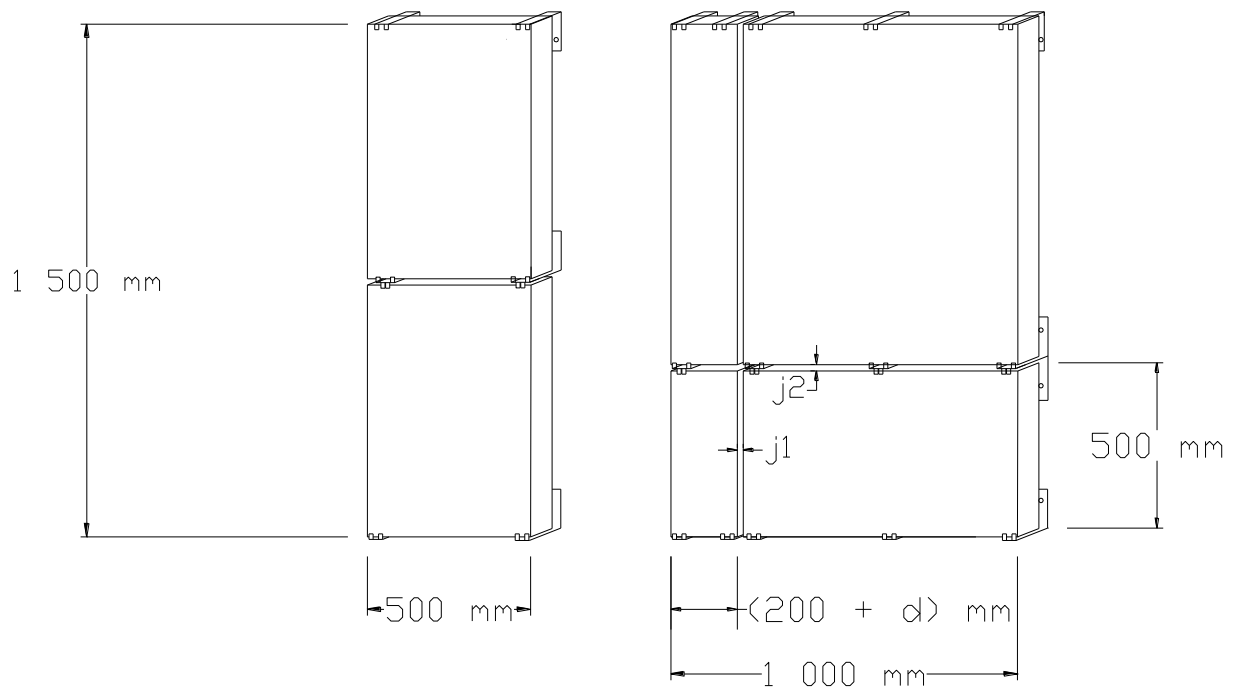

Figure B.2a: Example of installation for cladding elements without grooves.

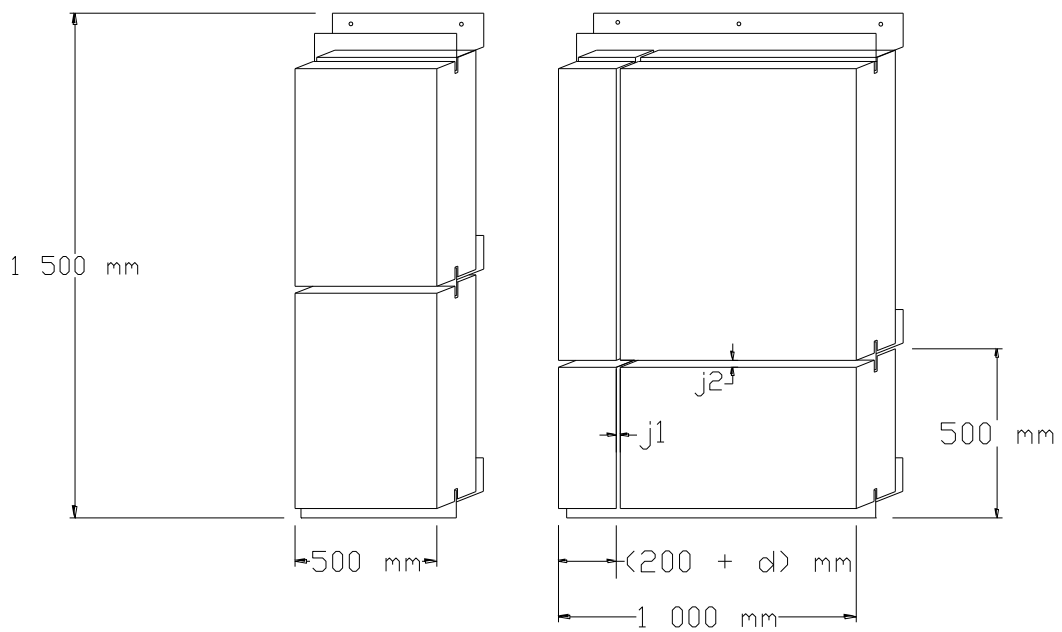

Figure B.2b: Example of installation for cladding elements with grooves.

ANNEX C – ADDITIONAL CRITERIA FOR WATERTIGHTNESS TESTS

A transparent material panel (PMMA thickness 8 mm) with 3 mm diameter holes (0,01 % holes) could be placed behind the cladding (see Figure C.2 and Figure C.3).

E.g., if the size of sample is 2400 x 1200 mm, the display of holes could be made according to Figure C.1.

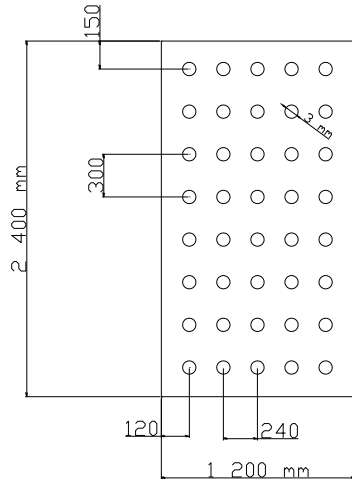

Figure C.1: Example of distances between holes.

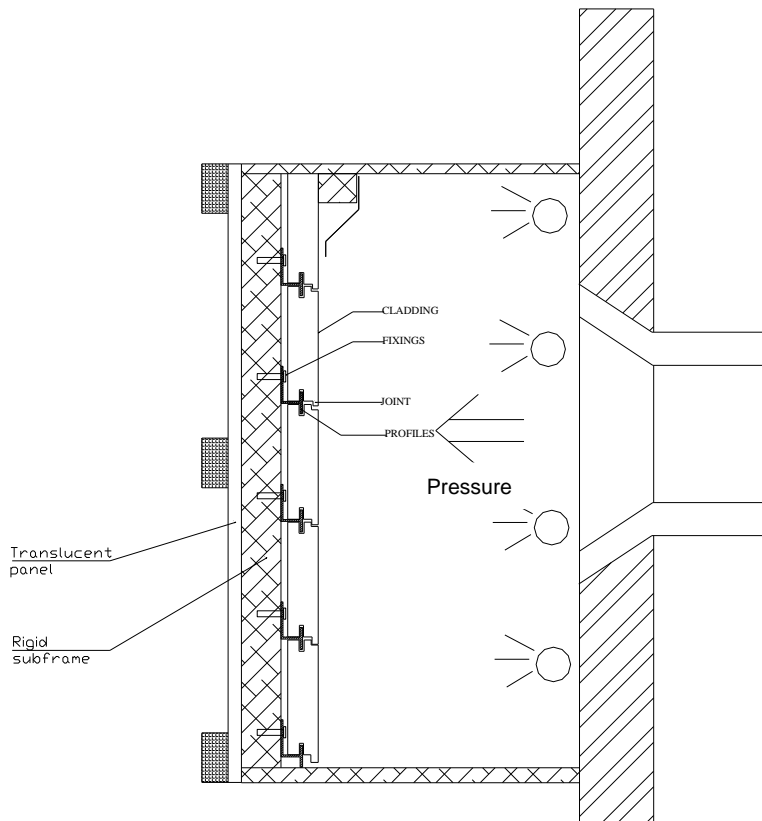

Figure C.2: Example of test device – vertical section.

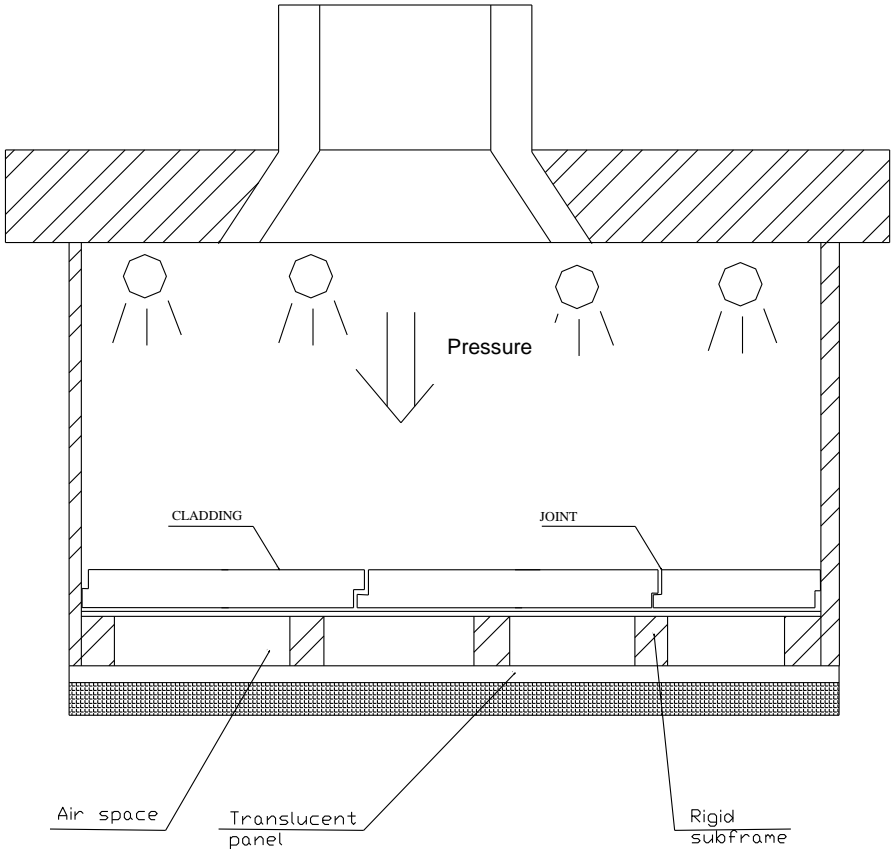

Figure C.3: Example of test device – horizontal section.

ANNEX D – WIND SUCTION AND PRESSURE LOAD TESTS

The principle is to establish the effects of suction and pressure loads on the assembled system.

The number of tests depends on the combination of parameters presented for the assembled systems.

As a minimum, the mechanically weakest design shall be tested.

D.1 Wind suction test

D.1.1 Preparation of the test specimen

The test specimen shall be mounted in the test equipment in accordance with the manufacturer instructions.

The test specimen is defined as follows:

- A non airtight substrate (test rig) such as wood or steel rigid frame.
- The assembled system must be fixed to the test rig.
- The dimensions of the test specimen depend on the size of external cladding element and the specified cladding fixings :
 - for cladding elements which are mechanically fixed independent of each other, a minimum surface cladding of 1,5 m² shall be tested.
 - If they depend on each other vertically and horizontally, at least 3 x 3 elements shall be tested.
 - If they depend on each other vertically or horizontally, at least 4 elements shall be tested.
- To define the mechanically weakest design the following aspects shall be taken into account:
 - The mechanically weakest cladding element (e.g. minimum thickness, minimum bending strength, minimum grooved cladding element resistance, etc.)
 - Minimum density of cladding fixings.
 - Maximum span between profiles.
 - Maximum span between brackets.

The tolerances due to manufacturing and/or installation and deformations due to temperature and humidity variations have to be taken into account.

D.1.2 Test equipment

The test equipment consists of a pressure or suction chamber (see Figure D.1) against which is placed the assembled system. The depth of chamber shall be sufficient for a constant pressure or suction to be exerted on the test specimen applied to the external surface of the assembled system irrespective of its possible deformation. The chamber is mounted on a rigid frame. The assembled system acts as the seal between the chamber and the environment. The connection between the assembled system and the chamber shall be sufficient to allow a realistic deformation of the test specimen under the influence of simulated wind suction.

Alternative test equipment

The alternative test may be used, provided that the geometric shape allows the foil bags to be placed in the air space and be blown out so that a uniformly distributed pressure load at the rear face of the cladding is possible.

The test rig consists of a rigid frame (steel construction) made of vertical longitudinal girder and horizontal profiles (anchor channel) and rigid boards or a massive wall such as masonry or concrete.

The subframe of the cladding kit has to be fixed on the rig and the cladding elements have to be fixed on the subframe according to the indications given by the ETA holder.

The vertical profiles of the rig can be movable (sliding) so that they can be placed in the axis of the fixings of the cladding.

Foil bags which are placed in the air space at the rear side of the cladding are blown out and they exert a uniformly distributed pressure load on the rear face of the cladding which corresponds to the wind suction load.

D.1.3 Test procedure

The uniformly distributed loads are exerted on the surface of the assembled system.

The test is performed in successive steps (two steps of 300 Pa, one step of 500 Pa and one step of 1000 Pa, then steps of +200 Pa thereafter, at each step the load is maintained constant for at least 10 seconds and returned to zero after each step; see Figure D.2) until significant irreversible deformation (deformation which affects serviceability) or failure occurs.

The test is then continued until failure occurs.

The deflection shall be measured, at the relevant points (e.g. central point of the cladding element, border or corner of the cladding element, cladding fixing, profiles, etc.), as a function of the load and reported in tabular or graphic form.

With the differential pressure reduced to zero, the permanent deflection shall be noted after 1 minute recovery. The pressure at which defect or damage occur shall be noted.

Additionally, if relevant, the permanent deflection 1 hour after failure occurs shall be noted.

The fixings between the assembled system and the test equipment shall not constitute weak points and shall therefore be chosen accordingly.

D.1.4 Observations during the test

Failure is defined by any one of the following events:

- Any cladding element, cladding fixing, profile or bracket breaks.
- Any cladding element, cladding fixing, profile or bracket presents a significant permanent deflection.

D.1.5 Test results

The test result is:

- The failure load Q.
- The type of failure.
- The value of maximum permanent deflection (after 1 minute recovery), the maximum deflection of the test specimen and the load and sensor position for this maximum permanent deflection and maximum deflection.

D.1.6 Test specimen description

It is necessary to describe the test specimen by giving details about:

- Brackets (material, geometry, distance between two brackets and number and disposition of fixings).
- Profiles (material, geometry and distance between two profiles).
- Cladding element (material and geometry).
- Cladding fixing (material and geometry and number and disposition of fixings).
- Fixings between the test equipment and the assembled system (position, generic type, material and geometry).

D.2 Wind pressure test

The test procedure is similar to D.1, the only difference being that the wind action is reversed.

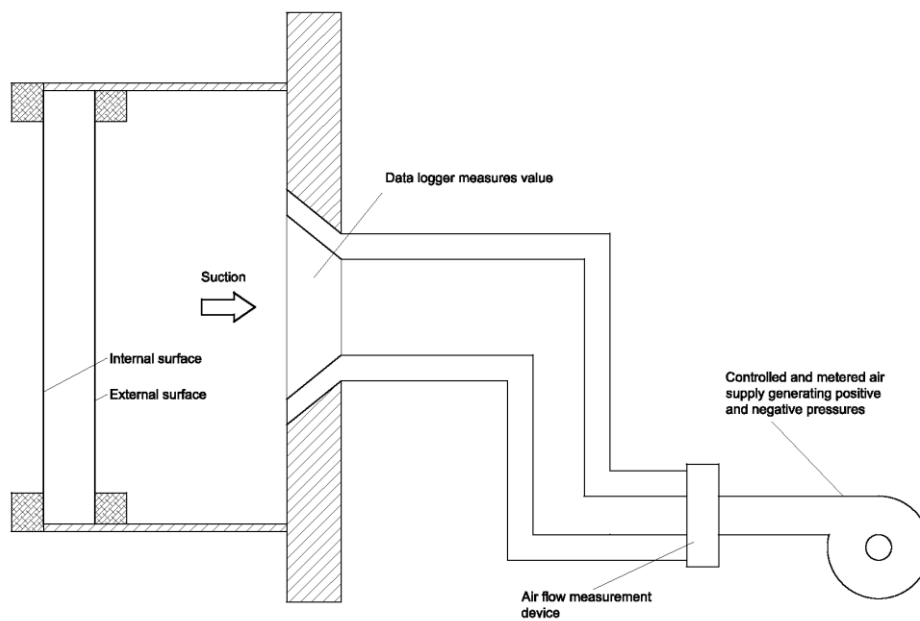

Figure D.1: Example of wind pressure and suction apparatus.

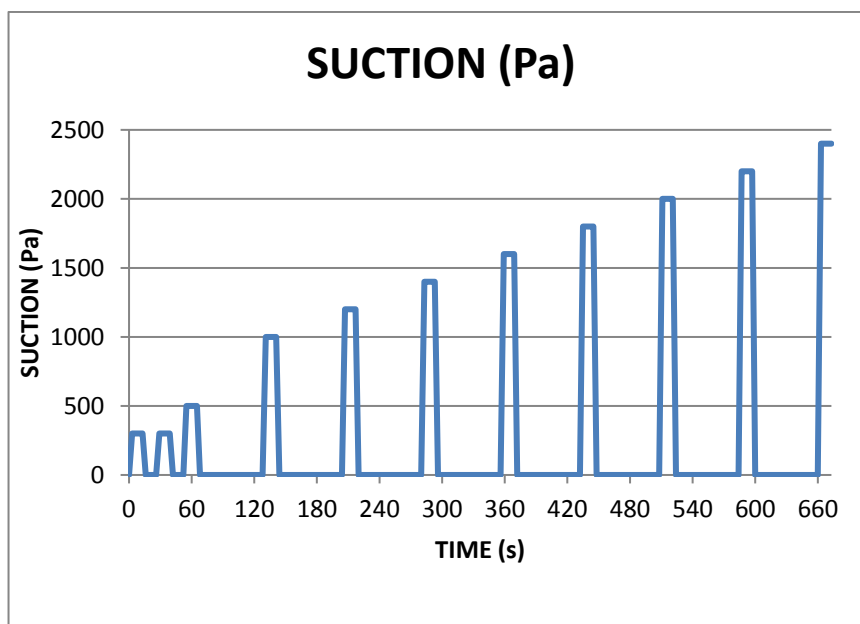

Figure D.2: Example of wind load steps.

ANNEX E – RESISTANCE TO VERTICAL LOAD TEST

The principle is to establish the effects of vertical loads on the assembled systems when the cladding fixings are in their vertical load resistance limit (obtained as indicated in section 2.2.9).

The cladding fixings vertical load resistance limit (R_v) is defined as:

- In the case of punctual cladding fixings (e.g. clips, small rails, pins, clamps, hungs, etc.), the mean value of vertical force for 1 mm irreversible deformation obtained according to the method indicated in Annex H.
- In the case of linear cladding fixings (e.g. profiles), the minimum value of the vertical force obtained by calculation taking into account the elastic limit and the admissible deflection of the cladding fixing.

At least, the mechanically weakest design of the cladding fixings and subframe brackets shall be tested.

One cladding element is installed on the cladding fixings and the subframe and an additional dead load is added on top of the cladding element. The subframe brackets shall be fixed to a test rigid substrate in accordance with the instructions of the manufacturer.

The additional dead load shall be chosen taking into account the dead load of the cladding element (Q_w) used in the specimen, the vertical load resistance limit as defined above (R_v) and the number of cladding fixings (N) that will support the vertical force.

$$Q_{ad} = R_v \times N - Q_w$$

The displacement of the cladding fixings and subframe profiles shall be measured.

The test can be stopped when the deflection, after adding the dead load, is less than 0,1 mm after 1 hour.

The test result is a deflection curve as a function of time and the maximum deflection.

ANNEX F – IMPACT RESISTANCE TEST

F.1 General

The principle is to establish the impact resistance of the cladding kit considering hard body and soft body impacts. Besides, it is established the impact use categories to correspond to the degree of exposure to impacts in use.

The bodies to impact and the test equipment are indicated in EOTA TR 001. The points of impact shall be selected taking into account the behaviour of the cladding element and the substrate, varying according to whether the impact point is or is not located in an area of greater rigidity (at less than 50 mm from the edge of cladding element).

Hard body impacts are:

- H1 and H2 (1 J and 3 J respectively), carried out with the steel ball weighing 0,5 kg and from a height of 0,20 m and 0,61 m respectively (at least in three locations).
- H3 (10 J), carried out with the steel ball weighing 1,0 kg and from a height of 1,02 m (at least in three locations).

Soft body impacts are:

- Small soft body S1 and S2 (10 J and 60 J respectively), carried out with the soft ball weighing 3,0 kg and from a height of 0,34 m and 2,04 m respectively (at least in three locations).
- Large soft body S3 and S4 (100 J and 400 J respectively), carried out with the spherical bag weighing 50,0 kg and from a height of 0,61 and 0,82 m respectively (at least in the space between two profiles).

Note: National building regulations in some member states may have specific requirements. The manufacturer may consider other energy values for the hard and soft body impacts. Any change shall be indicated in the ETA.

At least, the mechanically weakest design shall be tested.

The size of the test specimen shall be chosen to carry out all the impacts indicated in table F.1.

The dimensions of any indentation shall be reported. Noted shall be made of any damage caused.

F.2 Test procedure

Test procedure can be carried out using one of following options:

1. When the impact resistance is chosen by the manufacturer or it is known, using the impact tests indicated in table F.1 for this impact resistance chosen or known.
2. When the impact resistance is not known, using the sequence for the impact tests, indicated in table F.2, with the aim of obtaining the maximum impact resistance.

Table F.1 - Hard and soft body impact tests.

External impacts and assessment						
			Category IV	Category III	Category II	Category I
Hard body impact	H1	<ul style="list-style-type: none"> Weight: 0,5 kg Impact: 1 J (height 0,20 m) No. impacts: 3 Position of impacts: three different locations 	No penetrated (2) No perforated (3)	---	---	---
	H2	<ul style="list-style-type: none"> Weight: 0,5 kg Impact: 3 J (height 0,61 m) No. impacts: 3 Position of impacts: three different locations 	---	No penetrated (2) No perforated (3)	No deterioration (1)	No deterioration (1)
	H3	<ul style="list-style-type: none"> Weight: 1 kg Impact: 10 J (height 1,02 m) No. impacts: 3 Position of impacts: three different locations 	---	---	No penetrated (2) No perforated (3)	No deterioration (1)
Soft body impact	S1	<ul style="list-style-type: none"> Weight: 3 kg Impact: 10 J (height 0,34 m) No. impacts: 3 Position of impacts: three different locations 	No deterioration (1)	No deterioration (1)	---	---
	S2	<ul style="list-style-type: none"> Weight: 3 kg Impact: 60 J (height 2,04 m) No. impacts: 3 Position of impacts: three different locations 	---	---	No deterioration (1)	No deterioration (1)
	S3	<ul style="list-style-type: none"> Weight: 50 kg Impact: 300 J (height 0,61 m) No. impacts: 1 Position of impacts: At least in the centre point of a cladding element 	---	---	No deterioration (1)	---
	S4	<ul style="list-style-type: none"> Weight: 50 kg Impact: 400 J (height 0,82 m) No. impacts: 1 Position of impacts: At least in the centre point of a cladding element 	---	---	---	No deterioration (1)
<p>(1) Superficial damage, provided there is no cracking, is considered as showing "no deterioration" for all the impacts.</p> <p>(2) The test result is assessed as being "penetrate" if there is any cracking penetrating to be observed in the cladding element (to be also observed by the rear side) in at least 2 of 3 impacts. Superficial cracking (no penetrating) is allowed.</p> <p>(3) The test result is assessed as being "perforated" if there is a destruction of the cladding element (to be also observed by the rear side) in at least 2 of 3 impacts.</p>						

F.3 Impact test sequence

When the impact resistance is not known, it is possible to obtain the maximum impact resistance following the increasing sequence for the impact tests, indicated in the table F.2.

To start the sequence indicated in the table F.2, it is considered that the assembled system might have the maximum impact resistance (impact use category I). If it is necessary, the manufacturer can choose to start the sequence from other impact resistance.

Table F.2 - Impact test sequence.

Impact H2	In the case of no cracks appear, then carry out the hard body impact H3.
	In the case of superficial cracks appear but without penetrations or breaks (no penetrated and no perforated), then carry out the soft body impact S1. If the S1 impact result is satisfactory, the assembled system should be classified as Category III.
	In the case of penetrations or breaks appear, then carry out the hard body impact H1 and after that, the soft body impact S1. If the H1 and S1 impact results are satisfactory, the assembled system should be classified as Category IV.
Impact H3	In the case of no cracks appear, then carry out the soft body impact S2.
	In the case of superficial cracks appear but without penetrations or breaks (no penetrated and no perforated), then carry out the soft body impact S2.
	In the case of penetrations or breaks appear, then carry out the soft body impact S1. If the S1 impact result is satisfactory, the assembled system should be classified as Category III.
Impact S2	In the case of no cracks appear, and no cracks have appeared during the hard body impact H3, the TAB and the manufacturer may choose if carry out the soft body impact S4 directly (to obtain the Category I) or carry out the S3 impact (to secure the Category II) before the S4 impact.
	In the case of cracks, penetrations or breaks appear; carry out the soft body impact S1. If the S1 impact result is satisfactory, the assembled system should be classified as Category III or IV (taking into account the hard body impact results).
Impact S3	In the case of no cracks appear, and hard body impacts H2 and H3 have been satisfactory, the assembled system should be classified as Category II.
	In the case of cracks, penetrations or breaks appear; carry out the soft body impact S1. If the S1 impact result is satisfactory, the assembled system should be classified as Category III or IV (taking into account the hard body impact results).
Impact S4	In the case of no cracks appear, and hard body impacts H2 and H3 have been satisfactory, the assembled system should be classified as Category I.
	In the case of cracks, penetrations or breaks appear; and the soft body impact S3 has not been carried out previously, then carry out the soft body impact S3.
NOTE: In the case of the H1 or S1 impact results will not be satisfactory, the assembled system must not be classified.	

F.4 Definition of the impact use categories

The categories given in table F.3 correspond to the degrees of exposure in use. They do not include an allowance for acts of vandalism.

Table F.3 - Impact use categories.

Category	Use
I	A zone readily accessible at ground level to the public and vulnerable to hard body impacts but not subjected to abnormally rough use. (e.g.: Façade bases in buildings sited in public locations, such as squares, schoolyards or parks. Cleaning gondolas can be used on the façade).
II	A zone liable to impacts from thrown or kicked objects, but in public locations where the height of the kit will limit the size of the impact; or at lower levels where access to the building is primarily to those with some incentive to exercise care (e.g.: Façade bases in buildings not sited in public locations (e.g. squares, schoolyards, parks) or upper façade levels in buildings sited in public locations that occasionally can be hit by a thrown object (e.g. ball, stone, etc.). Cleaning gondolas can be used on the façade).
III	A zone not likely to be damaged by normal impacts caused by people or by thrown or kicked objects (e.g.: Upper façade levels in buildings (not including base) not sited in public locations, that occasionally can be hit by a thrown object (e.g. ball, stone, etc.). Cleaning gondolas cannot be used on the façade).
IV	A zone out of reach from ground level (e.g. High façade levels that cannot be hit by a thrown object. Cleaning gondolas cannot be used on the façade).

ANNEX G – GROOVED CLADDING ELEMENT RESISTANCE TEST

G.1 General

The principle is to establish the mechanical resistance of the grooved cladding element.

A minimum of 5 specimens shall be tested.

Samples with a fitting are applied to a rigid substrate as shown in Figure G.1.

The force shall be exerted at a rate of 5 mm/min on the profile.

The force is applied by pulling the head of the profile. If other cladding fixings are used (instead of profile), then the length (L) of the cladding fixings may be < 100 mm.

The dimensions "a" and "b" depend on the cladding kit and also on the material, geometry and fabrication tolerances of the cladding element.

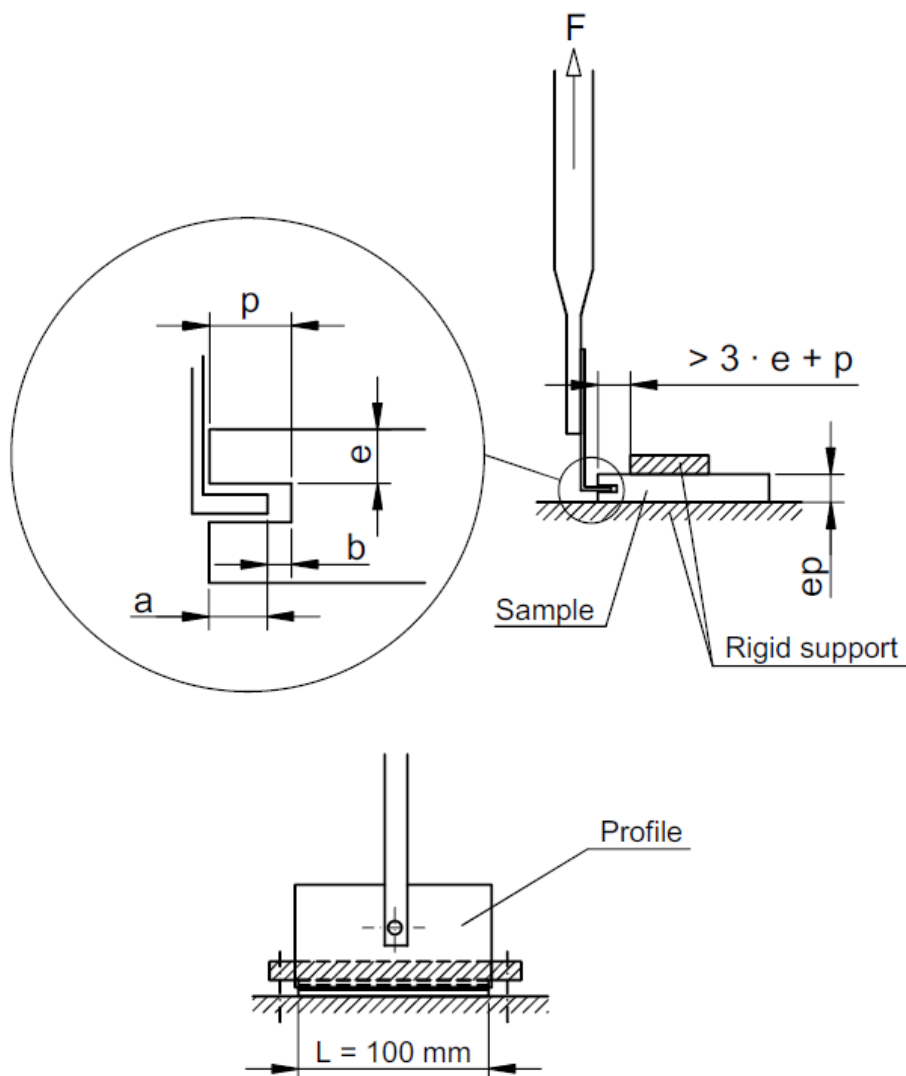

Figure G.1: Example of test specimen fixing.

G.2 Test report

Test report should include:

- Type and geometry of the test specimen (values of “e”, “p”, “a”, “b” and “ep” indicated in Figure G.1).
- Type, material and geometry of the profile or cladding fixing used to exert the force.
- Each individual force value, F_i (expressed in N), and the description of the failure of the test specimen (breakage of the cladding element, significant permanent deflection of the profile or cladding fixing, etc.).
- The mean value, F_m , and the characteristic value, F_c , in accordance with section G.3.

G.3 Test results statistical interpretation

$$F_c = F_m - k_n \cdot S$$

Where:

F_c = the characteristic force giving 75% confidence that 95% of the test results will be higher than this value.

F_m = the mean force.

k_n = the variable as a function of the number of test specimens for 5% ($p = 0,95$) with 75% confidence level when the population standard deviation is unknown (see Table G.1).

S = the standard deviation of series under consideration.

Table G.1 – The variable k_n as a function of the number of test specimens (see EN 1990 Eurocode: *Basis of structural design*, Table D1, V_x , unknown).

Number of specimens	3	4	5	6	7	8	10	20	30	∞
Variable k_n	3,37	2,63	2,33	2,18	2,10	2,00	1,92	1,76	1,73	1,64

ANNEX H – MECHANICAL RESISTANCE OF CLADDING FIXINGS

The principle is to establish the mechanical resistance of punctual cladding fixings (e.g. clips, small rails, pins, clamps, hungs, etc.).

H.1 General

The tests shall be carried out under normal environmental laboratory conditions, $(20 \pm 10) ^\circ\text{C}$ and $(50 \pm 20)\%$ relative humidity.

A minimum of 5 specimens shall be tested.

The cladding fixing shall be installed as specified by the manufacturer.

The force must be exerted at a rate of 5 mm/min on the cladding fixing.

The test is performed in successive steps with a return to zero at each level, until 1 mm irreversible deformation occurs.

Note: To obtain the forces with accuracy, it is recommended to make the control by displacement of the growth between cycles. This type of control is the best to avoid big gaps between the residual distortions that occur after each consecutive cycle.

The test is then continued until failure occurs.

The displacements and forces shall be measured and reported in tabular or graphic form.

H.2. Vertical load resistance (weight)

The test specimen consists of one cladding fixing applied to a rigid substrate as shown in Figure H.1.

The force must be exerted as shown in Figure H.1.

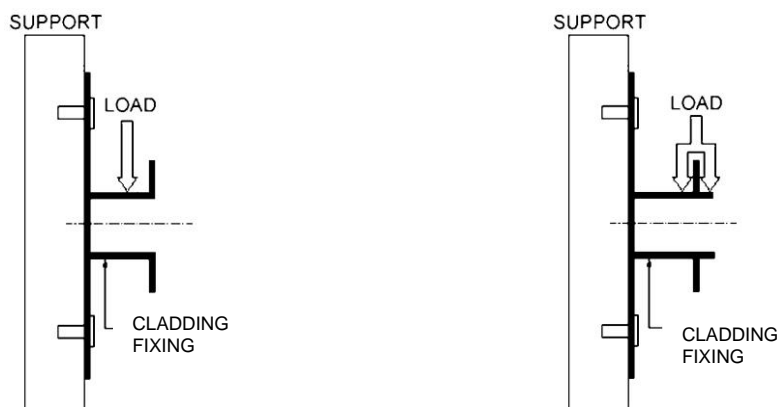

Figure H.1: Examples of test lay-out for vertical load resistance test.

H.3 Horizontal load resistance (wind suction)

The test specimen consists of one cladding fixing applied to a rigid substrate as shown in Figure H.2.

The force must be exerted as shown in Figure H.2.

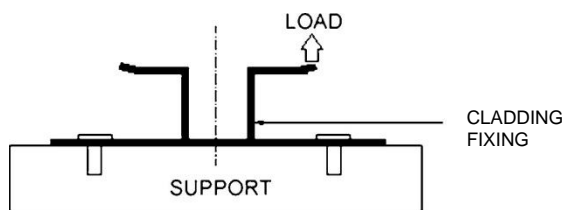

Figure H.2: Examples of test lay-out for horizontal load resistance test.

H.4 Test report

Test report should include:

- Type, material and geometry of the cladding fixing.
- Each individual displacement and force value, F_i (expressed in N), for 1 mm irreversible deformation.
- Each individual failure value, F_{iu} (expressed in N), and the mode of failure description of the test specimen (brackage, significant permanent deflection, etc.).
- The displacements and forces shall be measured and reported in tabular or graphic form.
- The mean values, F_m , and the characteristic values, F_c , in accordance with section H.5.

H.5 Test results statistical interpretation

$$F_c = F_m - k_n \cdot S$$

Where:

F_c = the characteristic force giving 75% confidence that 95% of the test results will be higher than this value.

F_m = the mean force.

k_n = the variable as a function of the number of test specimens for 5% ($p = 0,95$) with 75% confidence level when the population standard deviation is unknown (see Table H.1).

S = the standard deviation of series under consideration.

Table H.1 – The variable k_n as a function of the number of test specimens (see EN 1990 Eurocode: *Basis of structural design*, Table D1, V_x , unknown).

Number of specimens	3	4	5	6	7	8	10	20	30	∞
Variable k_n	3,37	2,63	2,33	2,18	2,10	2,00	1,92	1,76	1,73	1,64

ANNEX I – PULL-THROUGH / PULL-OUT RESISTANCE TEST

The principle is to establish the resistance of the connection between the profiles of the subframe and the cladding fixings.

The test shall comprise one or more of the following tests:

- a) simple pull-through test, to determine the resistance of the fixing through the perforation in the subframe profile,
- b) simple pull-out test, to determine the resistance of the fixing through the perforation in the subframe profile,
- c) combination of the pull-through and pull-out test, to determine the resistance of the connection between the subframe profile and the cladding fixing.

The manufacturer shall decide which of these tests shall be carried out taking into account the cladding kit configurations.

I.1 Preparation of the test specimen

For each pull-through, pull-out or the combination of both, a minimum of 3 specimens shall be tested.

The test specimens must be mounted in accordance with the manufacturer instructions.

Each test specimen will be composed of:

- Options a) and b): one subframe profile and the fixing defined for its connection with the cladding fixing,
- Option c): the subframe profile, the cladding fixing and the fixing defined for the connection between them.

The length of the subframe profile should be 300 mm approximately, however, depending on the cladding kit configuration, other dimensions may be chosen.

Test specimens shall be conditioned for at least 2 hours at (23 ± 2) °C before the test.

I.2 Test equipment

The apparatus must consist of:

- A dynamometer,
- A test support as shown in the following figures, depending on the type of test indicated above.

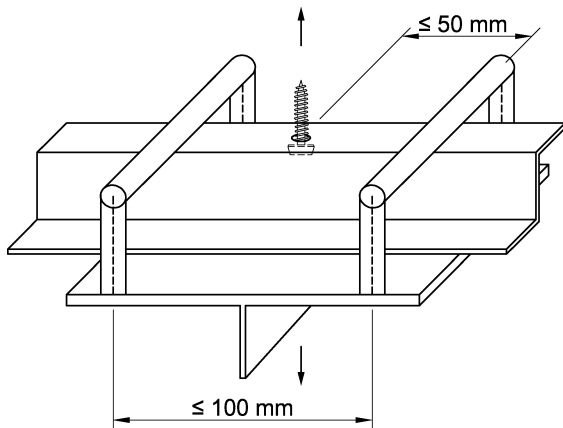

Figure I.1: Example of pull-through test.

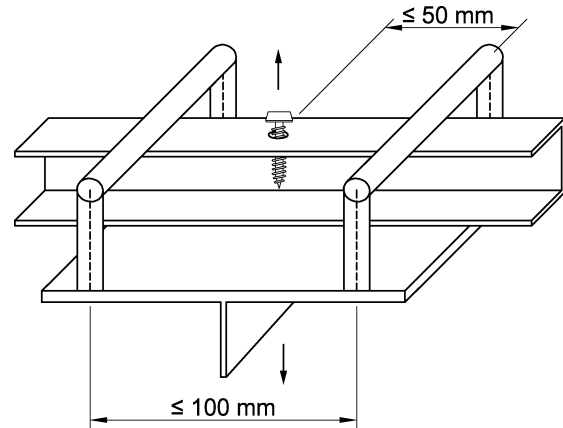

Figure I.2: Example of pull-out test.

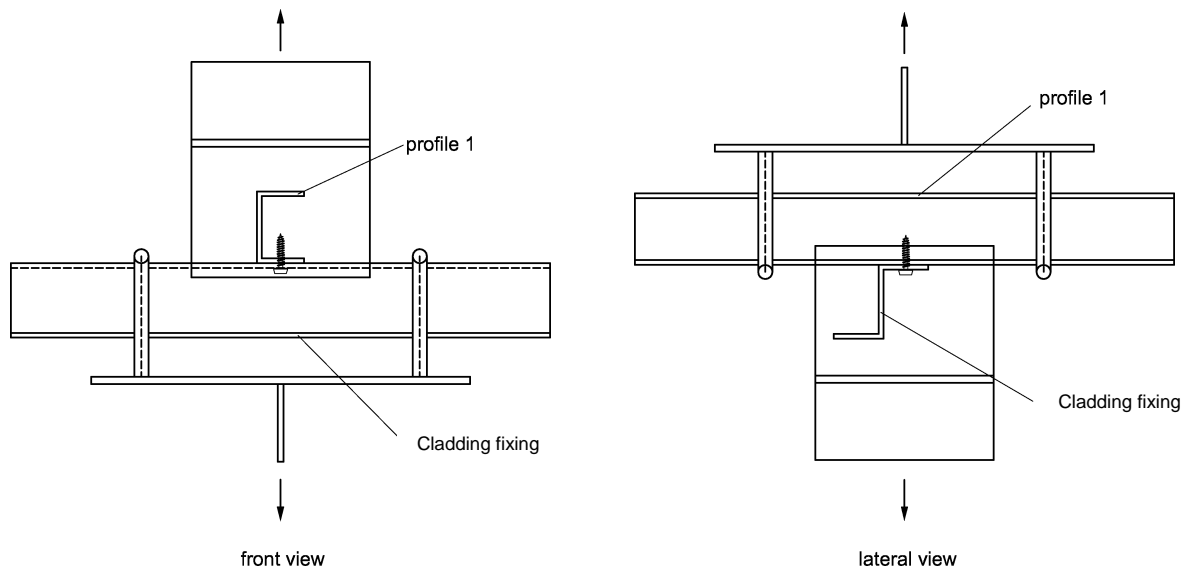

Figure I.3: Example of pull-through and pull-out combination test.

I.3 Test procedure

The test shall be carried out using a tensioning speed of 20 mm/min. When relevant, lower speed may be considered.

In tests options a) and b), the fixing must be placed perpendicular to the subframe profile as described in Figure I.1 and Figure I.2, and the force must be applied either through the support or by the fixing until failure.

In test option c), the force must be applied through the supports until failure.

Failure must be defined by any one of the following events:

1. Any profile breaks.
2. Any fixing breaks.

I.4 Test results and test report

The pull-through resistance and/or the pull-out resistance are expressed in N.

The test report shall detail the following in accordance with section I.5:

- Each individual F_i , value.
- The mean F_m , value.
- The characteristic F_C value giving 75 % confidence that 95 % of the test results will be higher than this value.
- The mode of failure description.
- The type of fixing and a description of the fixing (e.g. geometry and dimensions).

I.5 General test results statistical interpretation

$$F_C = F_m - k_n \cdot S$$

Where:

F_C = the characteristic breaking force giving 75% confidence that 95% of the test results will be higher than this value.

F_m = the mean breaking force, either under tension or shear.

k_n = the variable as a function of the number of test specimens for 5 % ($p = 0,95$) with 75% confidence level when the population standard deviation is unknown (see Table I.1).

S = the standard deviation of series under consideration.

Table I.1 – The variable k_n as a function of the number of test specimens (see EN 1990 Eurocode: *Basis of structural design*, Table D1, V_x , unknown).

Number of specimens	3	4	5	6	7	8	10	20	30	∞
Variable k_n	3,37	2,63	2,33	2,18	2,10	2,00	1,92	1,76	1,73	1,64

ANNEX J – BRACKETS RESISTANCE (HORIZONTAL AND VERTICAL LOAD) TEST

J.1 General

The aim of the test is to determine the load bearing capacity and wind resistance of the brackets and their fixings to the subframe under shear and tension loads respectively.

Resistance of brackets shall be tested under:

- Vertical load (weight), see section J.4.1.
- Horizontal load (wind), see section J.4.2.

Test and measuring equipment shall be in accordance with section J.2.

Test specimens shall be tested in accordance with section J.3.

J.2 Test equipment

The equipment is made of a traction machine of class 1 in accordance with EN ISO 7500-1, minimum capacity of 1000 daN, in the vertical axis, whose main elements are the following:

- a lower part allowing fixing of the brackets to the profile
- an upper mobile part allowing fixing to the profile.

These parts must be placed in the same axis.

Additionally a load-displacement measurement device shall be used.

The lower part of the support is made of a rigid substrate (e.g. a horizontal basis and a vertical perpendicular surface, see Figure J.2).

This substrate shall:

- be rigidly fixed on the lower tray of the machine,
- be rigid enough to allow the correct execution of the test.

Whenever the substrate is not made of steel, steel plates shall be used to provide a support surface under the brackets (minimum thickness 5 mm and with a surface area at least equal to the surface of the bracket wing, incorporating a hole of diameter equal to that of fixing).

The upper part consists of a traction device appropriate to the section of the profile.

The upper mobile part and the attached profile shall be vertically aligned with the substrate.

Displacements under load can be taken equal to displacements of the mobile crosspiece but it is preferable to have sensors of displacement:

- either in the axis of the profile
- or on the head of each bracket

Displacement sensors are linked up with a graphic recorder allowing to draw the curve strength-displacement (see Figure J.1).

J.3 Mounting provisions of test specimens

J.3.1 Fixings of brackets to substrate

Brackets shall be fixed to the substrate according to the following:

- Vertical load test shall be in accordance with Figure J.2.
- Horizontal load test shall be in accordance with Figure J.3.
- The worst position of the fixings (the weakest design) considering the use shall be tested.
- The type of anchor between the bracket and the substrate must be chosen according to the type of substrate and the ETA-holder specifications. Whenever no fixings to substrate are defined by the manufacturer, bolts of suitable diameter adapted to predrilling (\varnothing 6 mm minimum) by using washers shall be used.
- The fixing bolt (anchor) on the support shall be positioned in the oblong hole at the maximum specified distance from the profile.

Note: The anchors (fixing between the bracket and the substrate) shall not represent a weak point of the test specimen.

J.3.2 Brackets

Each test specimen shall consist of one (asymmetrical) or two brackets mounted in accordance with the specifications of the manufacturer.

Nevertheless, an asymmetrical bracket may be tested by means of two brackets in opposition on both sides of the profile. The test may be done on a single bracket as well (asymmetric layout).

Whenever several lengths of wings are available, at least the weakest mechanically bracket configuration shall be tested.

J.3.3 Fixings profile-bracket

Profile shall be fixed to brackets according to the following:

- The type of bracket fixing on the profile must correspond to the fixing to be used in the system.
- Fixings shall be installed in accordance with the specifications of the manufacturer.
- The worst position of the fixings (the weakest design) considering the use shall be tested.

J.3.4 Profile

Whenever it is possible the profile defined for the system shall be used in the test.

The metal profile can also be simulated by a square or rectangular section steel tube of 1,5 mm minimum thickness.

J.4 General test procedure (vertical and horizontal loads)

A minimum of 5 specimens shall be tested

Brackets are subjected to a succession of cycles during the test. In each cycle a growing load is applied and then returned to zero.

Figure J.1 shows an example of test procedure.

Load shall be applied in constant speed to the profile in order to avoid a dynamic failure of the test specimen.

Note: The term “displacement” refers to the measured distance at the head of wing during the application of the load. The term “Residual distortion” refers to the measured distance at the head of wing after the application of the load.

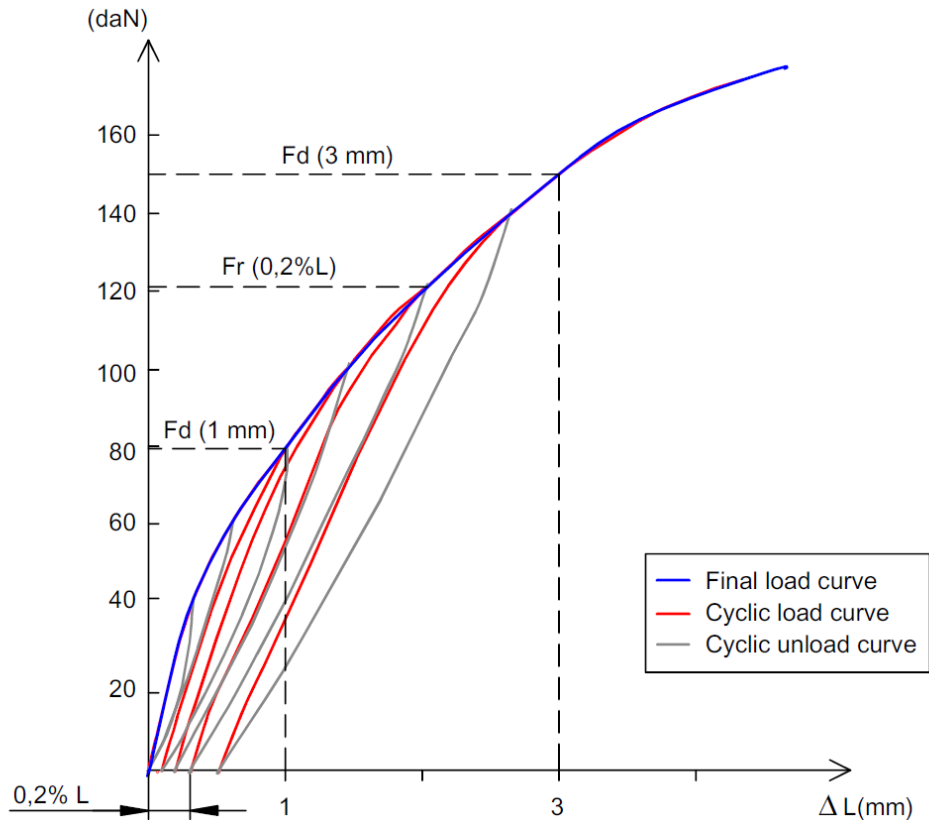

Figure J.1: Example of curve strength-displacement.

According to the typology of bracket, the manufacturer shall decide if cycles are defined either by means of load growths or by means of displacement growths under load.

Note: The manufacturer shall appraise the necessity for previous tests in order to define the most appropriate growth (load or displacement) for each bracket.

If the cycle succession is defined according to load growths, it shall be carried out in steps of 10 daN in vertical load resistance tests and in steps of 20 daN in horizontal load resistance tests. The load shall be applied in order to meet the condition: constant speed of load < 500 daN/min.

If the cycle succession is defined according to displacement growths, it shall be carried out in steps of 0,25 mm, 0,5 mm, or 1,0 mm depending on the behavior of the bracket under load. The load shall be applied in order to meet the condition: constant speed of load \leq 5 mm/min.

Mean and characteristic resistance shall be obtained for each test result series from the test specimens (“i” specimens) e.g. F_{r1} to F_{ri} ; F_{1d1} to F_{1di} ; F_{3d1} to F_{3di} and F_{s1} to F_{si} .

The characteristic resistance (R_{cr} , R_{cd1} , R_{cd2} and R_s) of the bracket is obtained according to section J.6.

J.4.1 Vertical load resistance test

Vertical load test shall be carried out considering the following:

- The test specimen shall be in accordance with Figure J.2.

- The test shall be carried out in accordance with section J.3.
- Test results shall be in accordance with section J.4.

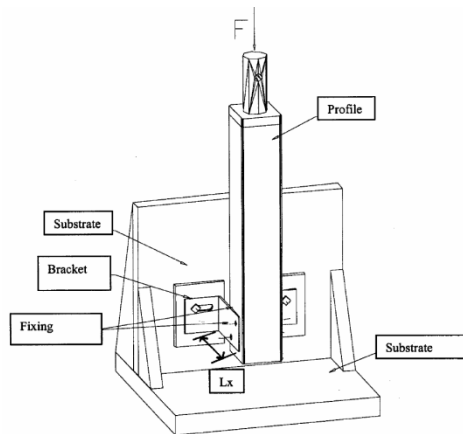

Figure J.2: Vertical load test. Example of test device.

Following results shall be recorded during the tests:

1st Criterion: F_r load

F_r is the load that causes a residual distortion on the bracket measured at the head of wing (after returning to zero) equal to:

$$\Delta L = \frac{0,2 \cdot L_x}{100} \quad \text{where } L_x \text{ is the length of the perpendicular wing to the substrate.}$$

Note: To obtain F_r with accuracy, growths between cycles (load or displacement) shall be appropriate in order to avoid big gaps between the residual distortions obtained after consecutive cycles.

2nd Criterion: F_{1d} and F_{3d} loads

F_{1d} and F_{3d} are the loads that cause a displacement under load of 1 and 3 mm respectively measured at the head of wing.

Note: Due to the fact that F_{1d} and F_{3d} are related to displacement values instead of residual distortion values, it is possible that loads F_{1d} and/or F_{3d} can be attained before F_r load is reached.

3rd Criterion: F_s Load

F_s is the load that corresponds to the failure.

Failure is defined by any one of the following events:

1. Any bracket breaks.
2. Any bracket presents a significant permanent deflection.
3. Any fixing breaks.

Note: When a failure is defined by a significant permanent deflection, a unified failure criterion (e.g. 10 mm displacement) shall be followed for all test specimens belonging to the same test group.

J.4.2 Horizontal load resistance test

Horizontal load test shall be carried out considering the following:

- The test specimen shall be in accordance with figure J.3. Brackets are fixed to the horizontal substrate.
- The test shall be carried out in accordance with section J.3.
- Test results shall be in accordance with section J.4.

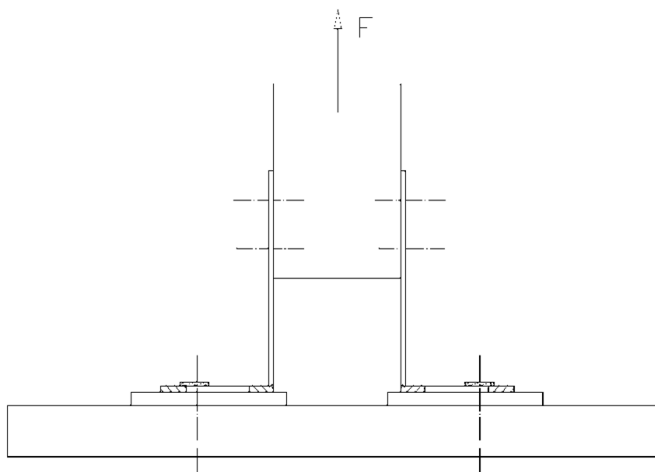

Figure J.3: Horizontal load test. Example of test device.

Following results shall be recorded during the tests:

1st Criterion: F_m Load

F_m is the load that causes a residual distortion on the bracket measured at the head of wing (after returning to zero) equal to 1 mm.

Note: To obtain F_m with accuracy, growths between cycles (load or displacement) shall be appropriate in order to avoid big gaps between the residual distortions obtained after consecutive cycles.

2nd Criterion: F_t Load

F_t is the load that corresponds to the failure.

Failure is defined by any one of the following events:

1. Any bracket breaks.
2. Any bracket presents a significant permanent deflection.
3. Any fixing breaks.

Note: When a failure is defined by a significant permanent deflection, a unified failure criterion (e.g. 10 mm displacement) shall be followed for all test specimens belonging to the same test group.

J.5 Test report

Test report shall include:

- Material and geometric characteristics of the brackets, including drawings of the brackets.
- Description of the failure of the test specimens (break, significant permanent deflection, failure of system fixings), including the failure criterion in case of failure due to significant permanent deflections.
- Figure including position and number of fixings between components for each test group.
- The number of brackets corresponding to the test results, including a reference to the use of symmetrical or asymmetrical brackets. Whenever a test has been carried out by means of two symmetrical brackets, test results shall clearly refer to the corresponding configuration.
- The curve strength-displacement for each test specimen.
- Identification of fixings (between the brackets and the substrate or between the brackets and the profile):
 - Description or generic type.
 - Dimensions (diameter, length, etc.).
 - Material.
 - Fixing method to the substrate.
 - Washers and nuts (if they are used):
 - Description or generic type.
 - Dimensions (diameter, length, etc.)
 - Material.

J.6 General test results statistical interpretation

$$F_{u,5} = F_{\text{mean}} - k_n \cdot S$$

Where:

$F_{u,5}$ = the characteristic breaking force giving 75 % confidence that 95 % of the test results will be higher than this value

F_{mean} = the mean breaking force, either under tension or shear

k_n = the variable as a function of the number of test specimens for 5 % ($p = 0,95$) with 75 % confidence level when the population standard deviation is unknown (see Table J.1)

S = the standard deviation of series under consideration

Table J.1 – The variable k_n as a function of the number of test specimens (see EN 1990 Eurocode: *Basis of structural design*, Table D1, V_x , unknown).

Number of specimens	3	4	5	6	7	8	10	20	30	∞
Variable k_n	3,37	2,63	2,33	2,18	2,10	2,00	1,92	1,76	1,73	1,64