

EUROPEAN ASSESSMENT DOCUMENT

EAD 130082-00-0603

December 2018

**FAÇADE FIXING SYSTEM - PLASTIC
BRACKET FOR FIXING TIMBER OR
WOOD BASED ELEMENTS TO THE
SUBSTRUCTURE**

The reference title and language for this EAD is English. The applicable rules of copyright refer to the document elaborated in and published by EOTA.

This European Assessment Document (EAD) has been developed taking into account up-to-date technical and scientific knowledge at the time of issue and is published in accordance with the relevant provisions of Regulation (EU) No 305/2011 as a basis for the preparation and issuing of European Technical Assessments (ETA).

Table of contents

1	Scope of the EAD	4
1.1	Description of the construction product	4
1.2	Information on the intended use(s) of the construction product	4
1.2.1	Intended use(s)	4
1.2.2	Working life/Durability.....	4
2	Essential characteristics and relevant assessment methods and criteria	5
2.1	Essential characteristics of the product	5
2.2	Methods and criteria for assessing the performance of the product in relation to essential characteristics of the product	6
2.2.1	Reaction to fire.....	6
2.2.2	Characteristic load-carrying capacity, stiffness and ductility	6
2.2.3	Head-pull-through parameter of the screws with regard to the polyamide	6
2.2.4	Strength of the polyamide material	6
2.2.5	Durability of polyamide.....	7
3	ASSESSMENT AND VERIFICATION OF CONSTANCY OF PERFORMANCE	8
3.1	System(s) of assessment and verification of constancy of performance to be applied	8
3.2	Tasks of the manufacturer	8
3.3	Tasks of the notified body	9
4	Reference documents	11
Annex A	Description of the construction product	12

1 SCOPE OF THE EAD

1.1 Description of the construction product

The fastener is a polyamide bracket, which is fixed to the timber substructure with screws. The shape of the bracket allows for fastening lamella shaped timber or wood-based façade elements to the substructure.

The screws themselves are not covered by this EAD. The screws are specified by the applicant with reference to their performance.

See Annex A for drawings of the polyamide bracket.

The product is not covered by a harmonised European standard.

Concerning product packaging, transport, storage, maintenance, replacement and repair it is the responsibility of the manufacturer to undertake the appropriate measures and to advise his clients on the transport, storage, maintenance, replacement and repair of the product as he considers necessary.

It is assumed that the product will be installed according to the manufacturer's instructions or (in absence of such instructions) according to the usual practice of the building professionals.

Relevant manufacturer's stipulations having influence on the performance of the product covered by this European Assessment Document, shall be considered for the determination of the performance and detailed in the ETA.

1.2 Information on the intended use(s) of the construction product

1.2.1 Intended use(s)

Fastening lamella shaped timber or wood based façade elements to the substructure.

The fasteners are intended for use in timber to timber connections, and the assessment does not cover use in alkaline environments.

1.2.2 Working life/Durability

The assessment methods included or referred to in this EAD have been written based on the manufacturer's request to take into account a working life of the fastener for the intended use of 25 years when installed in the works. These provisions are based upon the current state of the art and the available knowledge and experience.

When assessing the product the intended use as foreseen by the manufacturer shall be taken into account. The real working life may be, in normal use conditions, considerably longer without major degradation affecting the basic requirements for works¹.

The indications given as to the working life of the construction product cannot be interpreted as a guarantee neither given by the product manufacturer or his representative nor by EOTA when drafting this EAD nor by the Technical Assessment Body issuing an ETA based on this EAD, but are regarded only as a means for expressing the expected economically reasonable working life of the product.

¹ The real working life of a product incorporated in a specific works depends on the environmental conditions to which that works is subject, as well as on the particular conditions of the design, execution, use and maintenance of that works. Therefore, it cannot be excluded that in certain cases the real working life of the product may also be shorter than the assumed working life.

2 ESSENTIAL CHARACTERISTICS AND RELEVANT ASSESSMENT METHODS AND CRITERIA

2.1 Essential characteristics of the product

Table 1 shows how the performance of the façade fixing system is established in relation to the essential characteristics.

Table 1 Essential characteristics of the product and methods and criteria for assessing the performance of the product in relation to those essential characteristics

Nr	Essential characteristic	Method of verification and assessment	Type of expression of product performance (level, class, description)
Basic Works Requirement 2: Safety in case of fire			
1	Reaction to fire	2.2.1	Class
Basic Works Requirement 4: Safety in use			
2	Characteristic load-carrying capacity - Stiffness - Ductility	2.2.2	Level
3	Head-pull-through parameter of the screws with regard to the polyamide	2.2.3	Level
4	Strength of the polyamide material	2.2.4	Level
5	Durability of polyamide	2.2.5	Description

2.2 Methods and criteria for assessing the performance of the product in relation to essential characteristics of the product

2.2.1 Reaction to fire

The fastener shall be tested, using the test method(s) referred to in EN 13501-1 and relevant for the corresponding reaction to fire class. The product shall be classified according to Commission Delegated Regulation (EU) No 2016/364.

2.2.2 Characteristic load-carrying capacity, stiffness and ductility

The characteristic load bearing capacity, stiffness and ductility of a joint made with the fastener shall be determined in accordance with section 2.4.1 – in particular 2.4.1.1.3 of ETAG 015 and the associated EOTA Technical Reports. Specifically, EOTA TR 015 and TR 016 specifies the number of samples to be tested, how test forces are to be applied and how test results are to be presented.

The expressed performance of the tested sample shall be as a load bearing capacity related to the force direction, and the minimum insertion depth of the panel in the bracket, which is specified by the manufacturer and used in the test, is given in the ETA (after shrinkage and settling).

Note: The loadbearing capacity is determined by testing alone. Therefore, the embedding strength of the plastic components does not have to be determined separately.

2.2.3 Head-pull-through parameter of the screws with regard to the polyamide

The characteristic head pull-through parameter shall be determined by testing according to the test method given in EN 1383. However, the timber member foreseen in EN 1383 shall be replaced by a sample specimen of the polyamide bracket covered by this EAD. A minimum of 20 specimens is required. All parameters influencing the head pull-through parameter shall be examined.

The characteristic value of the head pull-through parameter for the tested screw in the fastener shall be calculated according to the principles given in EN 14358 and given in the ETA.

2.2.4 Strength of the polyamide material

The tensile properties of the polyamide shall be determined in accordance with EN ISO 527-1.

The factor for temperature influences the testing in accordance to EN ISO 527-1 is performed before and subjecting a sample to hot-cold cycles at -20°C/60°C.

The samples are made in accordance with EN ISO 527-2, and 5 samples are tested at ambient temperature and 5 samples are subjected to the below mentioned cycles.

The samples are subjected to five heat/cold cycles of 24 hours comprising the following phases:

- Exposure to $(60 \pm 5)^\circ\text{C}$ (rise for 1 hour) and maximum 30% RH for 7 hours (total of 8 hours),
- Exposure to $(-20 \pm 5)^\circ\text{C}$ (fall for 2 hours) for 14 hours (total of 16 hours).

The tensile strength, tensile modulus and other aspects of the tensile stress/strain relationship in accordance with EN ISO 527-1 shall be given in the ETA together with the factor for temperature influence. For calculation of strain method B in section 10.2.2.3 in EN ISO 527-1 shall be used.

2.2.5 Durability of polyamide

Note. The plastic bracket used for the application defined in the scope of this EAD are not exposed to UV-radiation for an extended period of time during the use as they are protected by the façade elements after installation.

Influence of moisture content

The moisture content of the plastic material may influence the load carrying capacity of the bracket. For the tests, 3 different humidity levels are defined.

- Standard: equilibrium water content at $T = +23\text{ °C}$ and 50 % relative humidity.
- Dry: equilibrium water content at $T = +23\text{ °C}$ and 10 % relative humidity.
- Wet: equilibrium water content after storing under water (wet condition means water saturated)

The samples are made in accordance with EN ISO 527-2. For standard humidity the conditioning may be done according to ISO 1110. The dry conditioning is reached by drying the sample in an oven at $+70\text{ °C}$ until the mass loss is smaller than 0,1 % in 3 consecutive measurement every 24 h. For an example the wet conditioning can be reached by placing the sample under water until the mass increase is smaller than 0,1 % in 3 consecutive measurements every 24 h.

For the bracket made from polyamide PA 6 the following moisture contents be taken:

- Standard: $2,5 \pm 0,2\text{ M\%}$ moisture content
- Dry: $\leq 0,2\text{ M\%}$ moisture content
- Wet: $\geq 6,0\text{ M\%}$ moisture content

The tension tests shall be carried out according to EN ISO 527-1 difference in % in the tension test for standard conditions compared to dry and wet conditions respectively shall be given in the ETA.

3 ASSESSMENT AND VERIFICATION OF CONSTANCY OF PERFORMANCE

3.1 System(s) of assessment and verification of constancy of performance to be applied

For the products covered by this EAD the applicable European legal act is: Decision 2003/640/EC.

The applicable AVCP system is 2+ for any use except for uses subject to regulations on reaction to fire.

For uses subject to regulations on reaction to fire the applicable AVCP systems regarding reaction to fire are 1, or 3, or 4 depending on the conditions defined in the said Decision.

3.2 Tasks of the manufacturer

The corner stones of the actions to be undertaken by the manufacturer of the polyamide brackets in the procedure of assessment and verification of constancy of performance are laid down in Table 2.

Table 2 Control plan for the manufacturer; corner stones

No	Subject/type of control (<i>product, raw/constituent material, component - indicating characteristic concerned</i>)	Test or control method	Criteria, if any	Minimum number of specimens	Minimum frequency of control
Factory production control (FPC)					
1	Checks on incoming materials	Supplier certificates or supplier tests			Every delivery
2	Reaction to fire	Acc. 2.2.1 of the EAD	Acc. to the Control Plan	Acc. to the Control Plan	Once a Year
3	Design specifications - Dimensions - Materials - Geometry	Measurement	Acc. to the Control Plan	Acc. to the Control Plan	Every batch
4	Tensile properties	EN ISO 527-1	Acc. to the Control Plan	Acc. to the Control Plan	Every batch

3.3 Tasks of the notified body

The corner stones of the actions to be undertaken by the notified body in the procedure of assessment and verification of constancy of performance for the polyamide brackets are laid down in Table 3.

Table 3 Control plan for the notified body under AVCP system 2+; corner stones

Subject/type of control (<i>product, raw/constituent material, component - indicating characteristic concerned</i>)	Test or control method	Criteria, if any	Minimum number of samples	Minimum frequency of control
Initial inspection of the manufacturing plant and of factory production control				
Initial inspection of the manufacturing plant and of factory production control carried out by the manufacturer regarding the constancy of performance of the brackets defined in the control plan (except reaction to fire).	As defined in control plan	As defined in control plan	As defined in control plan	According to the control plan
Continuous surveillance, assessment and evaluation of factory production control				
Continuous surveillance, assessment and evaluation of the factory production control carried out by the manufacturer regarding the constancy of performance of the brackets defined in the control plan (except reaction to fire).	As defined in control plan	As defined in control plan	As defined in control plan	According to the control plan

Regarding reaction to fire the involvement of the notified body is required only under the conditions defined in 99/90/EC amended by 2001/596/EC – in case of reaction to fire class A1, A2, B, C of the product for which a clearly identifiable stage in the production process results in an improvement of the reaction to fire classification (e.g. an additional of fire retardants or a limiting of organic material).

In this case the cornerstones of the tasks to be undertaken by the notified body under AVCP system 1 are laid down in table 4.

Table 4 Control plan for the notified body under AVCP system 1; corner stones

Subject/type of control (<i>product, raw/constituent material, component - indicating characteristic concerned</i>)	Test or control method	Criteria, if any	Minimum number of samples	Minimum frequency of control
Initial inspection of the manufacturing plant and of factory production control				
Initial inspection of the manufacturing plant and of factory production control carried out by the manufacturer regarding the constancy of performance related to reaction to fire and taking into account a limiting of organic material and/or the addition of fire retardants.	As defined in control plan	As defined in control plan	As defined in control plan	According to the control plan
Continuous surveillance, assessment and evaluation of factory production control				
Continuous surveillance, assessment and evaluation of the factory production control carried out by the manufacturer regarding the constancy of performance related to reaction to fire and taking into account a limiting of organic material and/or the addition of fire retardants.	As defined in control plan	As defined in control plan	As defined in control plan	According to the control plan

4 REFERENCE DOCUMENTS

As far as no edition date is given in the list of standards thereafter, the standard in its current version at the time of issuing the European Technical Assessment, is of relevance.

EN 13501-1:2007+A1:2009	Fire classification of construction products and building elements - Part 1: Classification using test data from fire reaction to fire tests
ETAG 015	European Technical Approval Guideline for three dimensional nailing plates – edition November 2012
EN 1383	Timber structures - Test methods - Pull through resistance of timber fasteners
EN 14358	Timber structures - Calculation of characteristic 5-percentile values and acceptance criteria for a sample
ISO 3167	Plastics - Multipurpose test specimens
EN 14592	Timber structures - Dowel-type fasteners – Requirements
EN ISO 527-1	Plastics - Determination of tensile properties - Part 1: General principles
ISO 1110	Plastics - Polyamides - Accelerated conditioning of test specimens
EN ISO 527-2	Plastics - Determination of tensile properties - Part 2: Test conditions for moulding and extrusion plastics
EOTA TR 015	Principles for the static calculation of connections made with Three-Dimensional Nailing Plates, with examples
EOTA TR 016	Method of testing Three-Dimensional Nailing Plates with examples

ANNEX A DESCRIPTION OF THE CONSTRUCTION PRODUCT



Figure A.1. Principle of the fixing system

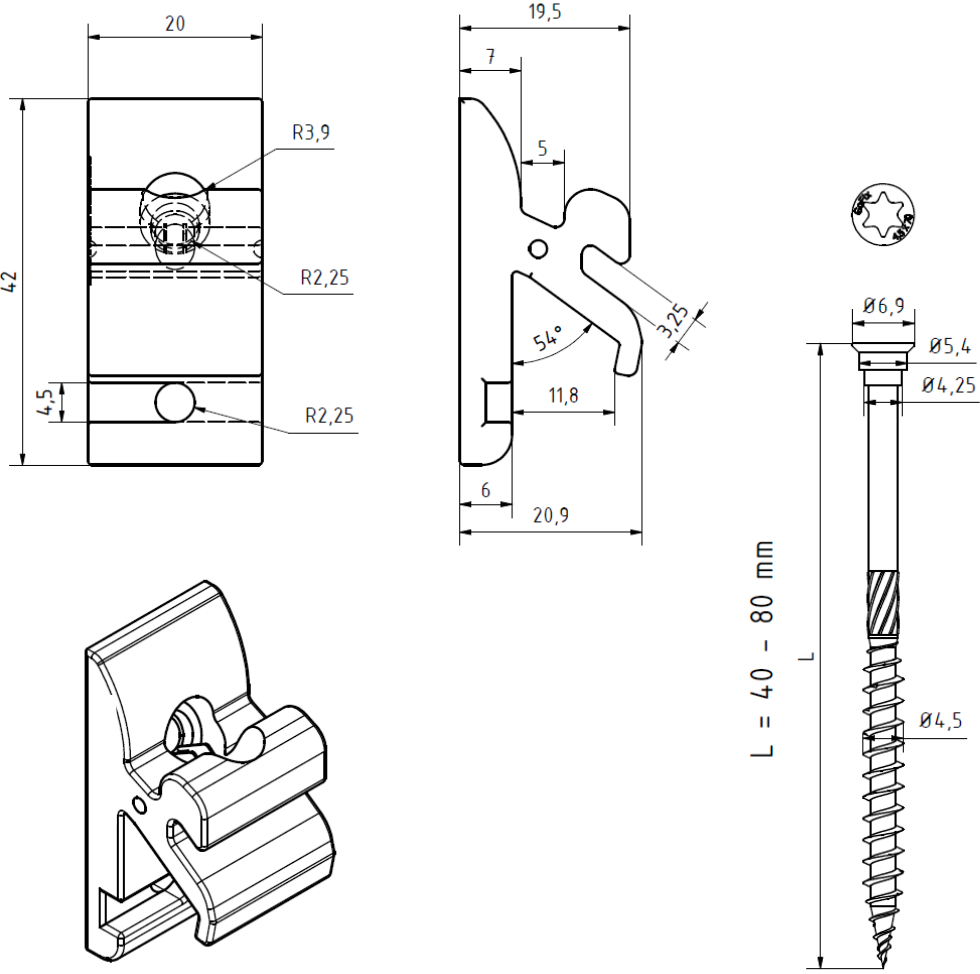

Figure A.2. Polyamide bracket and screw