



EUROPEAN ASSESSMENT DOCUMENT

EAD 200043-00-0103

June 2016

PILE PIPES MADE OF DUCTILE IRON

The reference title and language for this EAD is English. The applicable rules of copyright refer to the document elaborated in and published by EOTA.

This European Assessment Document (EAD) has been developed taking into account up-to-date technical and scientific knowledge at the time of issue and is published in accordance with the relevant provisions of Regulation (EU) No 305/2011 as a basis for the preparation and issuing of European Technical Assessments (ETA).

Contents

1	Scope of the EAD	4
1.1	Description of the construction product	4
1.2	Information on the intended use(s) of the construction product	4
1.2.1	Intended use(s).....	4
1.2.2	Working life/Durability.....	4
2	Essential characteristics and relevant assessment methods and criteria	5
2.1	Essential characteristics of the product	5
2.2	Methods and criteria for assessing the performance of the product in relation to essential characteristics of the product	5
2.2.2	Resistance to corrosion.....	6
2.2.3	Reaction to fire	6
3	Assessment and verification of constancy of performance	6
3.1	System(s) of assessment and verification of constancy of performance to be applied	6
3.2	Tasks of the manufacturer	6
3.3	Tasks of the notified body	7
3.4	Special methods of control and testing used for the verification of constancy of performance	8
3.4.1	Material properties.....	8
3.4.2	Dimensions (including tolerances)	8
4	Reference documents	9

1 SCOPE OF THE EAD

1.1 Description of the construction product

Pile pipes are ductile iron tubular pipes (spheroidal graphite cast iron) with spigot ends and conical pile sockets, which are joined together to a flexible choice of pile length. The conical pile socket and the spigot end form those parts of the pipe which ensure a proper and easily connection of pipes for pile units. When driven they form a rigid connection with resistance to compressive forces.

Pile pipes are manufactured in standards 5,5 m sections with external diameters of 118 mm or 170 mm and defined wall thickness.

Type 100: External diameter = 118 mm

Type 150: External diameter = 170 mm

Material properties according to Annex A and dimensions and tolerances according to Annex B.

Pile pipes are a component of completed piles.

The product is not covered by a harmonised European standard (hEN).

Concerning product packaging, transport, storage, maintenance, replacement and repair it is the responsibility of the manufacturer to undertake the appropriate measures and to advise his clients on the transport, storage, maintenance, replacement and repair of the product as he considers necessary.

It is assumed that the product will be installed according to the manufacturer's instructions or (in absence of such instructions) according to the usual practice of the building professionals.

Relevant manufacturer's stipulations having influence on the performance of the product covered by this European Assessment Document shall be considered for the determination of the performance and detailed in the ETA.

1.2 Information on the intended use(s) of the construction product

1.2.1 Intended use(s)

Pile pipes are used for piles for foundation of buildings, for foundation of civil engineering works, for foundation of pipeline constructions etc., which are designed for loading by axial compressive forces only.

The intended use is predominantly for static loads.

Due to resilient properties of ductile iron impact does not influence the product till ambient temperatures of -20°C and above.

Pile pipes are used in soils with or without groundwater with the exception of noncompacted and aggressive fills (e.g. ashes, slag).

Pile pipes, which are used for grout piles, are not covered by this EAD.

1.2.2 Working life/Durability

The assessment methods included or referred to in this EAD have been written based on the manufacturer's request to take into account a working life of the pile pipes made of ductile iron for the intended use of 100 years when installed in the works. These provisions are based upon the current state of the art and the available knowledge and experience.

When assessing the product the intended use as foreseen by the manufacturer shall be taken into account. The real working life may be, in normal use conditions, considerably longer without major degradation affecting the basic requirements for works¹.

The indications given as to the working life of the construction product cannot be interpreted as a guarantee neither given by the product manufacturer or his representative nor by EOTA when drafting this EAD nor by the Technical Assessment Body issuing an ETA based on this EAD, but are regarded only as a means for expressing the expected economically reasonable working life of the product.

2 ESSENTIAL CHARACTERISTICS AND RELEVANT ASSESSMENT METHODS AND CRITERIA

2.1 Essential characteristics of the product

Table 1 shows how the performance of pile pipes made of ductile iron is assessed in relation to the essential characteristics.

Table 1 Essential characteristics of the product and methods and criteria for assessing the performance of the product in relation to those essential characteristics

No	Essential characteristic	Assessment method	Type of expression of product performance
Basic Works Requirement 1: Mechanical resistance and stability			
1	Internal load bearing capacity	clause 2.2.1	level
2	Resistance to corrosion	clause 2.2.2	level
Basic Works Requirement 2: Safety in case of fire			
3	Reaction to fire	clause 2.2.3	class

2.2 Methods and criteria for assessing the performance of the product in relation to essential characteristics of the product

Characterisation of products to be assessed shall be done in accordance with available specifications, notably material properties and dimensions (including tolerances) given in Annex A and B.

2.2.1 Internal load bearing capacity

Pile pipes made of ductile iron shall have adequate resistance and safety against structural collapse and damage disproportionate to the original cause. The following aspect of internal load bearing capacity is relevant for pile pipes made of ductile iron:

¹ The real working life of a product incorporated in a specific works depends on the environmental conditions to which that works is subject, as well as on the particular conditions of the design, execution, use and maintenance of that works. Therefore, it cannot be excluded that in certain cases the real working life of the product may also be shorter than referred to above.

- Maximum permissible axial internal load bearing capacity

Maximum permissible axial internal load bearing capacity shall be calculated for each type and for each wall thickness separately in consideration of:

- Safety coefficient for the situation where the product is used (i.e. 1,5 as far as binding national regulations do not define higher values)
- Yield strength $R_p 0,2$ % of ductile iron
- Dimensions of pile pipes

Structural calculations shall be in accordance with relevant Eurocodes.

2.2.2 Resistance to corrosion

Ductile iron shall be durable especially regarding:

- Reduced internal load bearing capacities in consideration of thickness losses due to corrosion of 3 mm of the external diameter

Reduced internal load bearing capacity shall be calculated for each type and for each wall thickness separately in consideration of:

- Nominal internal load bearing capacity
- Thickness loss due to corrosion of 3 mm of the external diameter

2.2.3 Reaction to fire

The pile pipes made of ductile iron are considered to satisfy the requirements for performance class A1 of the characteristic reaction to fire in accordance with the EC Decision 96/603/EC (as amended) without the need for testing on the basis of it fulfilling the conditions set out in that Decision and its intended use being covered by that Decision.

3 ASSESSMENT AND VERIFICATION OF CONSTANCY OF PERFORMANCE

3.1 System(s) of assessment and verification of constancy of performance to be applied

For the products covered by this EAD the applicable European legal act is: Decision 98/214/EC

The system is: 2+

3.2 Tasks of the manufacturer

The cornerstones of the actions to be undertaken by the manufacturer of the product in the procedure of assessment and verification of constancy of performance are laid down in Table 2.

Table 2 Control plan for the manufacturer; cornerstones

No	Subject/type of control (<i>product, raw/constituent material, component - indicating characteristic concerned</i>)	Test or control method (<i>refer to 2.2 or 3.4</i>)	Criteria, if any	Minimum number of samples	Minimum frequency of control
Factory production control (FPC) [including testing of samples taken at the factory in accordance with a prescribed test plan]*					
1	Determination of material properties	3.4.1	Compliance to material properties stated in the ETA	According to the prescribed control plan	
2	Check of dimensions - external diameter - socket and spigot end - wall thickness - pile pipe length - straightness	3.4.2	Compliance to dimensions stated in the ETA	According to the prescribed control plan	

3.3 Tasks of the notified body

The cornerstones of the actions to be undertaken by the notified body in the procedure of assessment and verification of constancy of performance for pile pipes made of ductile iron are laid down in Table 3.

Table 3 Control plan for the notified body; cornerstones

No	Subject/type of control	Test or control method	Criteria, if any	Minimum number of samples	Minimum frequency of control
Initial inspection of the manufacturing plant and of factory production control					
1	It shall be ascertained that, in accordance with the control plan, the manufacturing plant of the single product manufacturer, in particular personnel and equipment, and the factory production control are suitable to ensure a continuous and orderly manufacturing of the pile pipes made of ductile iron according the European Technical Assessment.				
Continuous surveillance, assessment and evaluation of factory production control					
2	It shall be verified that the system of factory production control and the specified manufacturing process are maintained taking account of the control plan.				

3.4 Special methods of control and testing used for the verification of constancy of performance

3.4.1 Material properties

Requirements of ductile iron:

- Tensile strength
- Breaking elongation
- Brinell hardness
- Yield strength Rp 0,2 %
- Charpy notch energy (V-notch) at a temperature of -20°C
- Chemical composition
 - o Carbon (C)
 - o Silicon (Si)
 - o Manganese (Mn)
 - o Phosphorus (P)
 - o Sulphur (S)
 - o Magnesium (Mg)

The material properties tensile strength, breaking elongation, Brinell hardness and yield strength Rp 0,2 % of ductile iron shall be tested according to EN 545, clause 6.3 and 6.4. The Charpy notch energy (V-notch) at a temperature of -20°C shall be tested according to EN ISO 148-1. The chemical composition shall be determined by directional analysis.

3.4.2 Dimensions (including tolerances)

Following dimensions shall be measured:

- Dimensions of sockets
- Internal diameter
- External diameter
- Conus
- Conus length
- Dimensions of pile pipe shafts
- External diameter
- Wall thickness
- Pile pipe length
- Straightness
- Dimensions of spigot ends
- Conus
- External diameter
- Conus length

The dimensions of the product shall be measured according to EN 545, clause 6.1 and 6.2.

4 REFERENCE DOCUMENTS

As far as no edition date is given in the list of standards thereafter, the standard in its current version at the time of issuing the European Technical Assessment, is of relevance.

- EN 545 Ductile iron pipes, fittings, accessories and their joints for water pipelines - Requirements and test methods
- EN ISO 148-1 Metallic materials - Charpy pendulum impact test - Part 1: Test method

Annex A

Material properties

The material properties of the product correspond to the values given in Table A.

Table A

Tensile strength	$\geq 420 \text{ N/mm}^2$
Breaking elongation	$\geq 10 \%$
Brinell hardness	$\leq 230 \text{ HB}$
Yield strength $R_p 0,2 \%$	$\geq 300 \text{ N/mm}^2$
Charpy notch energy (V-notch) at a temperature of -20°C	$\geq 10 \text{ J}$
Chemical composition	
C	3,7 – 4,1 %
Si	1,7 – 2,3 %
Mn	$< 0,5 \%$
P	$< 0,1 \%$
S	$< 0,01 \%$
Mg	0,03 – 0,05 %

If the verified values correspond to those given in Table A for the characteristics stated below, the values given in Table B can be used for further calculation.

Table B

Compressive strength	700 N/mm^2
Modulus of elasticity	$164\,000 - 176\,000 \text{ N/mm}^2$
Density	7050 kg/m^3

Annex B

Dimensions (including tolerances)

The dimensions and the dimension tolerances of the product correspond to the values given in Table C.

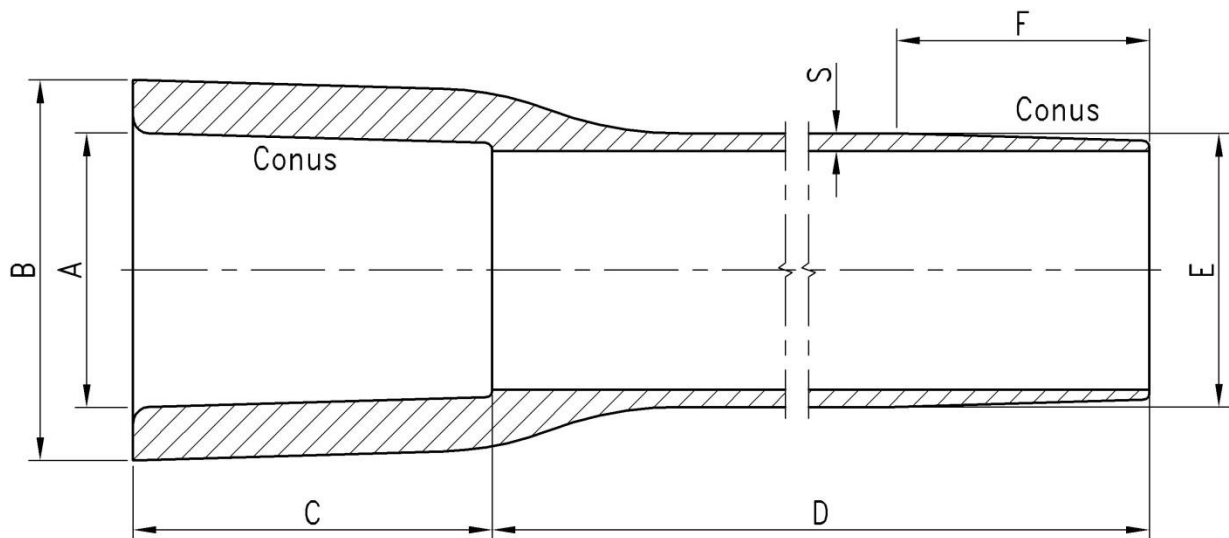

Table C

	Type 100 ¹⁾	Type 150 ¹⁾
SOCKET		
Internal diameter A [mm]	118,5 ± 0,5	171,5 ± 0,5
External diameter B [mm]	≥ 162	≥ 220
Conus	1:10 – 1:18	1:12 – 1:18
Conus length C [mm]	155 ± 1,0	215 ± 1,0
PILE PIPE SHAFT		
External diameter E [mm]	118 + 1,5/-1,0	170 + 2,5/-1,5
Wall thickness S [mm]	6,0 - 0,8	7,5 - 0,8
	7,5 - 0,8	9,0 - 0,8
	9,0 - 0,8	10,6 - 0,8
	10,6 - 0,8	
Pile pipe length D [mm]	5500 ± 50	5500 + 100/-50
Straightness	according to EN 545, 4,2,4: ≤ 0,125 % of the pile pipe length	according to EN 545, 4,2,4: ≤ 0,125 % of the pile pipe length
SPIGOT END		
Conus	1:10 – 1:18	1:12 – 1:18
External diameter E [mm]	118 + 1,5/-1,0	170 + 2,5/-1,5
Conus length F [mm]	110 – 20,0	150 – 20,0

¹⁾ Type 100, Type 150 – see clause 1.1