



EUROPEAN ASSESSMENT DOCUMENT

EAD 330924-00-0601

January 2018

CAST-IN ANCHOR BOLT OF RIBBED REINFORCING STEEL

The reference title and language for this EAD is English. The applicable rules of copyright refer to the document elaborated in and published by EOTA.

This European Assessment Document (EAD) has been developed taking into account up-to-date technical and scientific knowledge at the time of issue and is published in accordance with the relevant provisions of Regulation (EU) No 305/2011 as a basis for the preparation and issuing of European Technical Assessments (ETA).

Contents

1	Scope of the EAD	4
1.1	Description of the construction product	4
1.2	Information on the intended use of the construction product	5
1.2.1	Intended use.....	5
1.2.2	Working life/Durability.....	5
1.3	Specific terms used in this EAD (if necessary in addition to the definitions in CPR, Art 2)	6
1.3.1	Abbreviations.....	6
1.3.2	Notation.....	6
1.3.3	Indices.....	8
2	Essential characteristics and relevant assessment methods and criteria	9
2.1	Essential characteristics of the product	9
2.2	Methods and criteria for assessing the performance of the product in relation to essential characteristics of the product	9
2.2.1	Resistance to steel failure (tension load under static and quasi-static actions)	9
2.2.2	Resistance to pull-out failure	10
2.2.3	Resistance to concrete cone failure	10
2.2.4	Edge distance to prevent splitting failure under tension load	11
2.2.5	Minimum edge distance, spacing and thickness of concrete member to prevent splitting under installation torque	11
2.2.6	Maximum torque moment.....	12
2.2.7	Displacement under tension load	13
2.2.8	Resistance to steel failure under shear loading	13
2.2.9	Resistance to concrete edge failure without supplementary reinforcement	14
2.2.10	Resistance to pry-out failure.....	14
2.2.11	Displacement under shear load.....	14
2.2.12	Combined tension and shear load.....	15
2.2.13	Reaction to fire	15
2.2.14	Resistance to fire.....	15
3	Assessment and verification of constancy of performance.....	16
3.1	System(s) of assessment and verification of constancy of performance to be applied	16
3.2	Tasks of the manufacturer	16
3.2.1	General.....	16
3.2.2	Raw material	16
3.3	Tasks of the notified body	18
4	Reference documents	19
Annex A	Details of Tests and evaluation of the test results.....	20
A.1	General	20
A.2	Concrete	20
A.3	Installation	20
A.4	Steel tests	20
A.5	Tests	21
Annex B	General assessment methods.....	22
B.1	Conversion of failure loads to nominal strength	22
B.2	Establishing 5 % fractile	22

1 SCOPE OF THE EAD

1.1 Description of the construction product

This EAD covers the anchor bolts made of ribbed reinforcing steel, two hexagonal nuts and two washers with the following specifications:

- anchor bolts made of a ribbed reinforcing steel B500B (or B500C) according to EN 1992-1-1:2004 + AC 2010, Annex C with the following characteristics:

yield strength:	f_{yk}	$\geq 500 \text{ N/mm}^2$	$(\geq 500 \text{ N/mm}^2)$
ratio of tensile strength over yield strength:	$(f_u/f_y)_k$	$\geq 1,08$	$(\geq 1,15, \leq 1,35)$
characteristic elongation at maximum force	ϵ_{uk}	$\geq 5\%$	$(\geq 7,5 \%)$

- one of the ends of the bolt is provided with an anchor head, the other one with a thread
- anchor bolts with a ratio between head and diameter of the reinforcement bar ≥ 1.6
- inclination angle of head $0^\circ \leq \beta \leq 30^\circ$
- hexagon nuts acc. to EN ISO 4032:2012 and strength class 8 and 10 acc. to EN ISO 898-2:2012

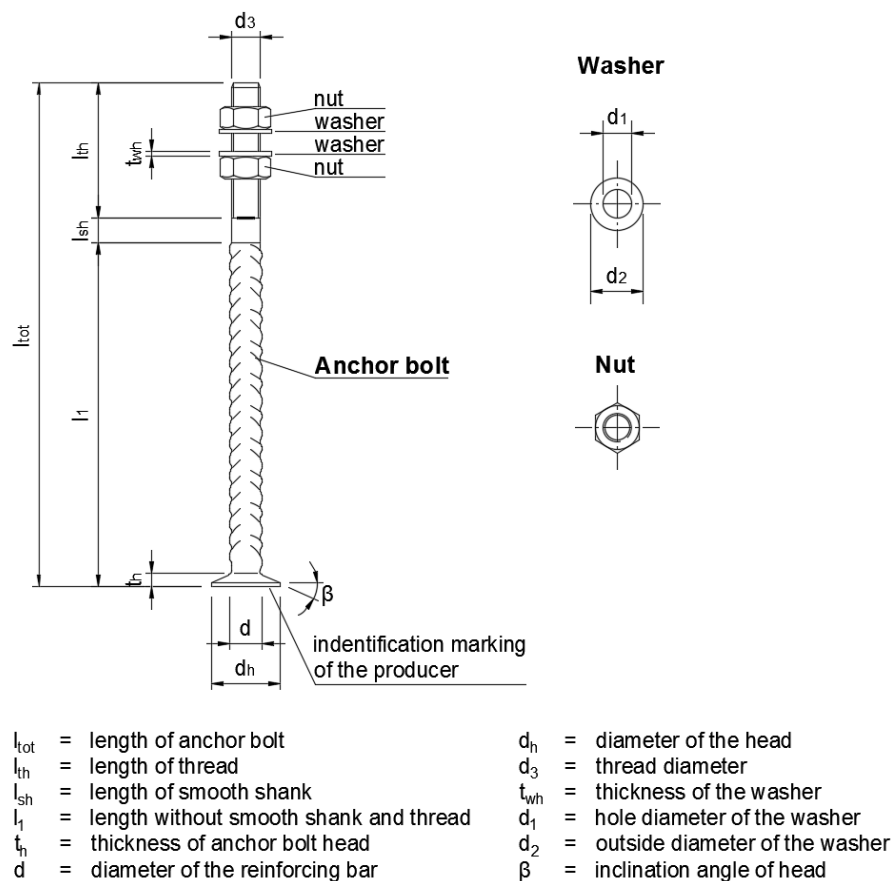

Figure 1: Example for anchor bolt with typical dimensions

The product is not covered by a harmonised European standard (hEN).

Concerning product packaging, transport, storage, maintenance, replacement and repair it is the responsibility of the manufacturer to undertake the appropriate measures and to advise his clients on the transport, storage, maintenance, replacement and repair of the product as he considers necessary.

It is assumed that the product will be installed according to the manufacturer's instructions or (in absence of such instructions) according to the usual practice of the building professionals.

Relevant manufacturer's stipulations having influence on the performance of the product covered by this European Assessment Document shall be considered for the determination of the performance and detailed in the ETA.

1.2 Information on the intended use of the construction product

1.2.1 Intended use

The anchor bolts are intended to be used for general application acc. Fig. 2 a) or for steel to steel contact acc. Fig. 2 b). Depending on the application one nut and washer or two nuts and washers shall be used for installation.

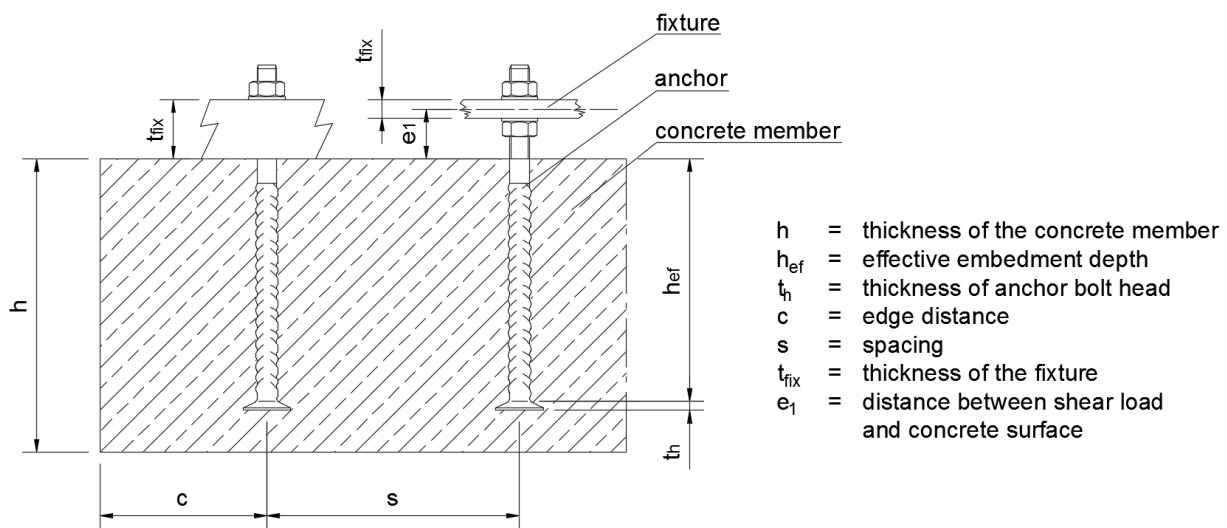

Figure 2: Intended use of the anchor bolt
a) General (optional) b) Steel to steel contact

This EAD covers the following specifications of the intended use:

- anchor bolts cast-in in reinforced normal concrete of a minimum strength class of C20/25 and a maximum strength class of C50/60 according to EN 206-1:2000 [4]
- cracked and in non-cracked concrete
- static and quasi-static loading
- one single anchor bolt or groups up to eight bolts
- corrosion resistance of the anchor bolts with appropriate concrete cover acc. EN 1992 or for dry internal conditions only (X1)

1.2.2 Working life/Durability

The assessment methods included or referred to in this EAD have been written based on the manufacturer's request to take into account a working life of the product for the intended use of 50 years when installed in the works (provided that the product is subject to appropriate installation (see 1.1)) These provisions are based upon the current state of the art and the available knowledge and experience.

When assessing the product the intended use as foreseen by the manufacturer shall be taken into account. The real working life may be, in normal use conditions, considerably longer without major degradation affecting the basic requirements for works¹.

The indications given as to the working life of the construction product cannot be interpreted as a guarantee neither given by the product manufacturer or his representative nor by EOTA when drafting this EAD nor by the Technical Assessment Body issuing an ETA based on this EAD, but are regarded only as a means for expressing the expected economically reasonable working life of the product.

1.3 Specific terms used in this EAD (if necessary in addition to the definitions in CPR, Art 2)

1.3.1 Abbreviations

- X1 = subject to dry internal conditions
- X2 = subject to dry internal conditions or external atmospheric exposure including industrial and marine environment or permanently damp internal condition, if no particular aggressive conditions exist
- X3 = subject to dry internal conditions or external atmospheric exposure including industrial and marine environment or permanently damp internal condition or permanently damp internal condition and in other particular aggressive conditions
Particular aggressive conditions are e. g. permanent, alternating immersion in seawater or the splash zone of seawater, chloride atmosphere of indoor swimming pools or atmosphere with extreme chemical pollution (e. g. in desulphurization plants or road tunnels where de-icing materials are used).

1.3.2 Notation

- A_h = load bearing area of the head of the anchor bolt
- A_s = stressed cross-section of the fastener used for determining the tensile capacity
- A_5 = rupture elongation
- b = width of concrete member
- β = inclination angle of the head
- c_1 = edge distance in direction 1
- c_2 = edge distance in direction 2
- $c_{cr,N}$ = edge distance for ensuring the transmission of the characteristic resistance in tension of a single fastener without edge and spacing effects in case of concrete cone failure
- $c_{cr,sp}$ = edge distance for ensuring the transmission of the characteristic resistance in tension of a single fastener without edge and spacing effects in case of splitting failure
- c_{min} = minimum allowable edge distance
- CV_F = coefficient of variation [%] related to loads
- d = diameter of the reinforcing bar (correspond to ϕ in EN 1992-1-1)
- d_h = diameter of the anchor head
- d_1 = hole diameter of the washer
- d_2 = outside diameter of the washer
- d_3 = thread diameter
- d_f = diameter of clearance hole in the fixture
- e_1 = distance between shear load and concrete surface

¹ The real working life of a product incorporated in a specific works depends on the environmental conditions to which that works is subject, as well as on the particular conditions of the design, execution, use and maintenance of that works. Therefore, it cannot be excluded that in certain cases the real working life of the product may also be shorter than referred to above.

ε_{uk}	= characteristic elongation at maximum force
F	= force in general (for the relevant test series N or V applies)
F_{Rk} (N_{Rk}, V_{Rk})	= characteristic resistance stated in the ETA
$F_{u,m,test}$	= mean failure load in a test series
$F_{u,c}$	= converted concrete failure load in a test
$F_{u,s}$	= converted steel failure load in a test
$F_{u,test}$	= failure load in a test
$F_{u,5\%,20}$	= 5% fractile of failure (ultimate) loads of a test series normalised to concrete strength C20/25
$F_{u,5\%}$	= 5% fractile of failure (ultimate) loads of a test series
$F_{u,95\%}$	= 95% fractile of failure (ultimate) loads of a test series
$F_{u,m}$	= mean value of failure (ultimate) loads of a test series
$f_{c,150,test}$	= compressive strength measured on cubes with a side length of 150 mm of concrete at the time of testing
$f_{ck,cube}$	= nominal characteristic concrete compressive strength (based on cubes)
f_c	= nominal characteristic concrete compressive strength (based on same test members as $f_{c,test}$)
$f_{c,test}$	= mean value of concrete compressive strength in a test series with test members stored and tested at the same time as the test for which the failure loads have to be converted
$f_{uk,test}$ OR $f_{u,test}$	= characteristic tensile strength of the anchor bolt in the test
$f_{yk,test}$	= characteristic tensile yield strength of the anchor bolt in the test
f_{yk}	= nominal characteristic steel yield strength of the anchor bolt
f_{uk} OR f_u	= nominal characteristic tensile strength of the anchor bolt (correspond to f_{tk} in EN 1992-1-1)
h	= thickness of the concrete member
h_{ef}	= effective embedment depth
h_{min}	= minimum thickness of concrete member
K_{cr}	= factor to take into account the influence of load transfer mechanism for applications in cracked concrete
K_s	= coefficient for estimation of fractiles for normal distribution when the population standard deviation s is unknown and for confidence level of 90% acc. [6]
K_{ucr}	= factor to take into account the influence of load transfer mechanism for applications in uncracked concrete
k_2	= factor to take into account the influence of load transfer mechanism in a group of anchors under shear
k_3	= ratio of characteristic resistance for concrete pry-out failure to characteristic resistance for concrete cone failure
k_7	= exponent for combined tension and shear load
l_1	= length of the anchor bolt without smooth shank and thread
l_f	= effective length of the anchor bolt
l_{th}	= length of the thread
l_{tot}	= total length of the anchor bolt
l_{sh}	= length of the shank
$M_{Rk,s}^0$	= characteristic bending resistance
N	= normal force (+N = tension force)
N_v	= prestressed tensile load due to installation torque
$N_{u,m}$	= mean ultimate tensile load of the tests in concrete
n	= number of tests of a test series

$s_{cr,N}$	= spacing for ensuring the transmission of the characteristic resistance in tension of a single fastener without edge and spacing effects in case of concrete cone failure
$s_{cr,sp}$	= spacing for ensuring the transmission of the characteristic resistance in tension of a single fastener without edge and spacing effects in case of splitting failure
s_{min}	= minimum allowable spacing
s_1	= spacing of fasteners in an fastener group in direction 1
s_2	= spacing of fasteners in an fastener group in direction 2
T	= torque moment
T_{inst}	= maximum recommended installation torque specified by the manufacturer
t_{fix}	= thickness of fixture
t_h	= thickness of anchor bolt head
t_{wh}	= thickness of the washer (correspond to h in EN 7089 and EN 7093)
V	= shear force
W_{el}	= resistance moment of the threaded part of the anchor bolt
γ_M	= recommended material partial safety factor according to CEN/TS 1992-4 [1] of the corresponding failure mode
$\delta_{N\infty}$	= long term tension displacement
$\delta_{V\infty}$	= long term shear displacement
$\delta(\delta_N, \delta_V)$	= displacement (movement) of the fastener at the concrete surface relative to the concrete surface outside the failure area in direction of the load (tension, shear) the displacement includes the steel and concrete deformations
$\psi_{ucr,N}$	= factor to take into account if the concrete is cracked or uncracked

1.3.3 Indices

cr	= cracked concrete
$calc$	= calculated value
fi	= fire
p	= pull-out
s	= steel
$test$	= tested result
u	= ultimate – situation when failure occurs
ucr	= uncracked concrete
5%	= 5% fractile of a test series
95%	= 95% fractile of a test series
20	= related to concrete strength class C20/25

2 ESSENTIAL CHARACTERISTICS AND RELEVANT ASSESSMENT METHODS AND CRITERIA

2.1 Essential characteristics of the product

Table 2.1 shows how the performance of the product is assessed in relation to the essential characteristics.

Table 2.1 essential characteristic of the product and methods and criteria for assessing the performance of the product in relation to those essential characteristics

No	Essential characteristic	Assessment method	Type of expression of product performance
Basic Works Requirement 1: Mechanical resistance and stability			
Characteristic values for tension loading under static and quasi-static actions			
1	Resistance to steel failure	2.2.1	$N_{Rk,s}$ [kN]
2	Resistance to pull-out failure	2.2.2	$N_{Rk,p}$ [kN]
3	Resistance to concrete cone failure	2.2.3	k_{cr} , k_{ucr} [-], h_{ef} , $C_{cr,N}$, $S_{cr,N}$ [mm]
4	Edge distance to prevent splitting failure	2.2.4	$C_{cr,sp}$, $S_{cr,sp}$ [mm]
5	Minimum edge distance, spacing and thickness of concrete member	2.2.5	C_{min} , S_{min} , h_{min} [mm]
6	Maximum torque moment	2.2.6	T_{inst} [Nm]
7	Displacement	2.2.7	δ_{N0} , $\delta_{N\infty}$ [mm]
Characteristic values for shear loading under static and quasi-static actions			
8	Resistance to steel failure	2.2.8	$V_{Rk,s}$ [kN], k_2 [-], $M^0_{Rk,s}$ [Nm]
9	Resistance to concrete edge failure without supplementary reinforcement	2.2.9	l_f , d_{nom} [mm]
10	Resistance to pry-out failure	2.2.10	k_3 [-]
11	Displacement	2.2.11	δ_{V0} , $\delta_{V\infty}$ [mm]
12	Combined tension and shear load	2.2.12	k_7 [-]
Basic Works Requirement 2: Safety in case of fire			
13	Reaction to fire	2.2.13	class
14	Resistance to fire	2.2.14	$N_{Rk,s,fi}$, $N_{Rk,p,fi}$, $V_{Rk,s,fi}$ [kN], $M^0_{Rk,s,fi}$ [Nm]

2.2 Methods and criteria for assessing the performance of the product in relation to essential characteristics of the product

2.2.1 Resistance to steel failure (tension load under static and quasi-static actions)

The characteristic resistance $N_{Rk,s}$ shall be determined for the thread diameter as follows and shall be confirmed by means of the test series of Table A.1, line 1.

$$N_{Rk,s,calc} = A_s \cdot f_{uk} \quad [N] \quad (1)$$

with:

$$A_s = \text{stress area of the thread} \quad [mm^2]$$

$$f_{uk} = \text{characteristic tensile strength of the bolt}$$

Determine the 5%-fractile of the failure loads. This value shall be normalized to account for over-strength of tested samples according to equation (B.2).

If the normalized 5%-fractile of the failure loads in the series is larger than $N_{Rk,s}$ than:

$$N_{Rk,s} = N_{Rk,s,calc} \quad [N]$$

else

$$N_{Rk,s} = N_{u,5\%} \quad [N]$$

with:

$$N_{u,5\%} = \text{normalized 5\%-fractile of the failure loads measured in the test series} \quad [N]$$

2.2.2 Resistance to pull-out failure

The characteristic resistance $N_{Rk,p}$ with pull-out is:

$$N_{Rk,p} = 6 \cdot A_h \cdot f_{ck,cube} \cdot \psi_{ucr,N} \quad [N] \quad (2)$$

with:

$$\begin{aligned} \psi_{ucr,N} &= 1,0 \text{ for fasteners in cracked concrete} \\ &= 1,4 \text{ for fasteners in uncracked concrete} \\ f_{ck,cube} &= \text{characteristic concrete compressive strength measured on cubes with a side} \\ &\quad \text{length of 150 mm} \quad [N/mm^2] \\ A_h &= \text{load bearing area of the head of the anchor bolt} \quad [mm^2] \\ &= \frac{\pi}{4} (d_h^2 - d^2) \\ d_h &= \text{head diameter} \quad [mm] \\ d &= \text{diameter of the reinforcing bar of the anchor bolt} \quad [mm] \end{aligned}$$

2.2.3 Resistance to concrete cone failure

The test series acc. to Table A.1, line 2 serve to check the calculation acc. [1] for large anchors. Determination of the maximum load shall be done with single fastenings without influence of spacing and edge distances.

Determine the mean value of the failure loads. This value shall be normalized to account for over-strength of tested samples according to equation (B.1).

If the normalized mean value of the failure load is larger than:

$$N_{Rm,c}^0 = 15.9 \sqrt{f_{c,150,test}} h_{ef,test}^{1.5} \quad [N] \quad (3)$$

with:

$$\begin{aligned} h_{ef,test} &= \text{effective embedments depth of the tests} \quad [mm] \\ f_{c,150,test} &= \text{measured concrete compressive strength of the specimens} \quad [N/mm^2] \end{aligned}$$

the calculation acc. [1] may be used with $k_{Cr} = 8.5$ and $k_{Ucr} = 11.9$,

else the factor k_{Ucr} may be calculated acc. to:

$$k_{Ucr} = N_{u,5\%} / \sqrt{f_{c,150,test}} / h_{ef,test}^{1.5} \quad [-] \quad (4)$$

with:

$$\begin{aligned} N_{u,5\%} &= 5\text{-fractile of the failure loads measured in the test series} \\ k_{cr} &= k_{ucr} / 1,4 \quad [-] \quad (5) \end{aligned}$$

The characteristic spacing and edge distance for the resistance under tension load is:

$$s_{cr,N} = 3 h_{ef} \quad [\text{mm}] \quad (6)$$

$$c_{cr,N} = 0,5 s_{cr,N} \quad [\text{mm}] \quad (7)$$

2.2.4 Edge distance to prevent splitting failure under tension load

Splitting failure of the member may occur during anchor loading. Minimum values for installation parameters (member thickness, edge distance and spacing) or minimum reinforcement should be provided by the manufacturer to avoid this failure. The tests acc. Table A.1, line 3 are optional.

Tests are not necessary if a minimum reinforcement is present to avoid splitting of the member.

The required cross-section of the minimum reinforcement is determined as follows:

$$\min A_s = 0,5 \cdot \frac{\sum N_{Ed}}{f_{yk} / \gamma_{Ms,re}} \quad \text{acc. to formula (18) of [1]} \quad [\text{mm}^2] \quad (8)$$

The optional tension tests are carried out unconfined at concrete members with minimum thickness h_{min} and with the edge distances $c_1 = c_2 = c$ with $c =$ estimated $c_{cr,sp}$.

The characteristic edge distance $c_{cr,sp}$ is evaluated from the results of tension tests on single fasteners at the corner. The mean failure load in the tests with fasteners at the corner shall be statistically equivalent the same as for a fastener without edge and spacing effects for the same concrete strength. If this condition is not fulfilled, the edge distance shall be increased accordingly.

The characteristic resistance to splitting $N_{Rk,sp}^0$ shall be determined by following Equation. It is the lower result of either characteristic resistance to pull-out failure ($N_{Rk,p}$ according to section 2.2.2 or to concrete failure $N_{Rk,c}$ according to [1]).

$$N_{Rk,sp}^0 = \min \{N_{Rk,c}; N_{Rk,p}\} \quad [\text{N}] \quad (9)$$

2.2.5 Minimum edge distance, spacing and thickness of concrete member to prevent splitting under installation torque

Splitting failure of the member may occur during fixture installation when anchor is placed acc. Fig. 2 a). Minimum values for installation parameters (member thickness, edge distance and spacing) or minimum reinforcement should be provided by the manufacturer to avoid this failure. The tests acc. Table A.1, line 4 are optional.

Tests are not necessary if a minimum reinforcement is present to avoid splitting of the member.

The required cross-section of the minimum reinforcement is determined as follows:

$$\min A_s = 0,5 \cdot \frac{\sum N_{Ed}}{f_{yk} / \gamma_{Ms,re}} \quad \text{acc. to formula (18) of [1]} \quad [\text{mm}^2] \quad (10)$$

The optional tests are carried out with double anchors with a spacing $s=s_{\min}$ and an edge distance $c=c_{\min}$ at a concrete member with minimum thickness h_{\min} . The anchors shall be alternately torqued in steps of $0.2 T_{\text{inst}}$. The test is stopped when the torque moment cannot be increased further or hairline cracks on the concrete surface are observed. Details of the test are described in TR 048 [13].

The chosen geometrical parameters c_{\min} , s_{\min} and h_{\min} are verified by the tests according to Table A.1 line 4. These values are correct if until the normalized 5% fractile of the torque moment reached $1.7 T_{\text{inst}}$ no cracks arise and the prestressing force is lower than steel failure $N_{Rk,s}$ according to section 2.2.1 and concrete failure for cracked concrete in low strength concrete $N_{Rk,c}$ according to [1].

$$T_{5\%} \geq 1.7 \cdot T_{\text{inst}} (f_{c,150,\text{test}} / f_{ck,\text{cube}})^{0.5} \quad [\text{Nm}] \quad (11)$$

2.2.6 Maximum torque moment

Verification of T_{inst} concerning transfer of torque moment into tension of the anchor bolt. Yielding of the steel or concrete cone failure of the member may occur during fixture installation when anchor is placed acc. Fig. 2 a) or yielding of the steel may occur during fixture installation when anchor is placed acc. Fig. 2 b). Maximum values for torque moment for installation acc. Fig. 2 a) and acc. Fig. 2 b) are required to avoid this yielding resp. failure. The tests acc. Table A.1, line 5 are optional.

The tests may be omitted if the prestressed tension force is calculated with a friction factor of $k = 0,1$:

$$N_{v95\%} = 1,3 T_{\text{inst}} / 0,1 / d_3 \quad [\text{N}] \quad (12)$$

with:

$$\begin{aligned} T_{\text{inst}} &= \text{Installation torque} & [\text{Nmm}] \\ d_3 &= \text{diameter of the thread} & [\text{mm}] \end{aligned}$$

In the optional tests the torque moment is applied on a cast in anchor bolt with a calibrated torque wrench until failure of the anchor bolt. The tension force in the anchor bolt shall be measured as a function of the applied torque moment.

After the test the connection between nut and bolt should be capable of being unscrewed.

The 95%-fractile of the prestressed tension force N_v generated in the torque tests at a torque moment $T = 1.3 T_{\text{inst}}$ shall be smaller than the nominal yield force of the anchor bolt respectively the minimum concrete failure load.

The nominal yield force of the anchor is the tension load which reaches at minimum the yield limit of all steel parts of the anchor.

For the calculation of the maximum torque moment T_{inst} the two different installation possibilities, as shown in Fig.1, have to be taken into account:

(a) General

In case of general application the maximum installation torque T_{inst} has to be determined taking into account the decisive failure mode between the steel one or the concrete ones. The characteristic tension resistances are evaluated with the minimum edge distance, spacing and member height as defined in Section 2.2.5.

$$N_{v95\%} / \min \{A_s f_{yk}\} \leq 1,0 \quad \text{and}$$

$$N_{v95\%} / \min \{N_{Rk,p}; N_{Rk,c}; N_{Rk,sp}; N_{Rk,cb}\} \leq 1,0$$

(b) Steel to steel contact

In case of steel to steel contact T_{inst} is calculated based on bolt yield strength, as the tension force (prestressing) is only applied on the anchor bolt.

$$N_{V95\%} / \min \{A_s f_{yk}\} \leq 1,0$$

If the generated prestressed tension force is higher than above mentioned yield force resp. characteristic resistances, T_{inst} should be reduced correspondingly.

2.2.7 Displacement under tension load

The characteristic displacements for short-term and quasi-permanent loading are specified for the tension load N in accordance with the following equation:

$$N = N_{RK} / (\gamma_F \cdot \gamma_M) \quad [N] \quad (13)$$

with:

$$\begin{aligned} N_{RK} &= \text{characteristic resistance} \\ \gamma_F &= 1,4 \\ \gamma_M &= \text{recommended partial safety factor for material acc. [1]} \end{aligned}$$

The displacements under short term tension loading (δ_{NO}) are evaluated from the tests with single anchors in concrete. The value derived shall correspond to the mean value.

The displacements δ_{NO} under short term tension loading may also be calculated according to [7] if the product is according to the assumptions of [7].

The long term tension loading displacements $\delta_{N\infty}$ may be assumed to be equal to 2,0 times the value δ_{NO} .

The displacements (in mm) should be rounded up to zero or five on the first place after the decimal point.

2.2.8 Resistance to steel failure under shear loading

The optional test series acc. to Table A.1, line 6 serve to determine the factor α_s . Determination of the maximum load shall be done with single fastenings without influence of spacing and edge distances.

Determine the 5%-fractile of the failure loads. This value shall be normalized to account for over-strength of tested samples according to equation (B.2).

The factor α_s may be calculated acc. to:

$$\alpha_s = V_{u,5\%} / A_{s,test} / f_{uk,test} \leq 0.6 \quad [-] \quad (14)$$

with:

$$\begin{aligned} V_{u,5\%} &= \text{normalized 5 \% -fractile of the failure loads measured in the test series} \quad [N] \\ A_{s,test} &= \text{stress cross-section in the area of the thread in the test} \quad [mm^2] \\ f_{uk,test} &= \text{characteristic tensile strength of reinforcement bar in the test} \quad [N/mm^2] \end{aligned}$$

Else for the verification the resistance to steel failure under shear load acc. CEN/TS 1992-4-2 [1], Table 2, Line 1 and 2 and appropriate sections 6.3.3.1 and 6.3.3.2 the following basic values are used:

(a) Without lever arm

The characteristic resistance $V_{RK,s}$ should be determined for the cross-section:

$$V_{RK,s} = \alpha_s \cdot A_s \cdot f_{uk} \quad [N] \quad (15)$$

with:

$$\begin{aligned} \alpha_s &= 0.5 \\ A_s &= \text{stress cross-section in the area of the thread} \\ f_{uk} &= \text{characteristic tensile strength of the reinforcement bar} \end{aligned}$$

The factor k_2 for fasteners in a group is:

k_2	=	1.0	for fasteners made of steel with normal ductility and $A_5 > 8\%$
k_2	=	0.8	for fasteners made of steel with rather low ductility and $A_5 \leq 8\%$

(b) With lever arm

The characteristic resistance $M_{Rk,s}^0$ should be determined for the cross-section of the reinforcement bar with reference to [1]:

$$M_{Rk,s}^0 = 1,2 \cdot W_{el} \cdot f_{uk} \quad [Nm] \quad (16)$$

with:

W_{el}	=	resistance moment of the threaded part of the fastener
	=	$(d_3/2)^3 \cdot \pi/4$
f_{uk}	=	characteristic tensile strength of the reinforcement bar

2.2.9 Resistance to concrete edge failure without supplementary reinforcement

For the calculation of the resistance to concrete edge failure without supplementary reinforcement acc. CEN/TS 1992-4-2 [1], section 6.3.5.2, formula (34) - (36) the geometrical values are used as follows:

l_f	=	effective length of the anchor bolt
	=	h_{ef} [mm] in case of uniform diameter of anchor bolt
	\leq	$8d_{nom}$
d_{nom}	=	thread diameter d_3 of anchor bolt
	\leq	60 mm

2.2.10 Resistance to pry-out failure

For the calculation of the resistance to pry-out failure acc. CEN/TS 1992-4-2 [1], section 6.3.4, formula (32) the factor k_3 is used as follows:

k_3	=	1.0	for anchorages with $h_{ef} < 60$ mm
k_3	=	2.0	for anchorages with $h_{ef} \geq 60$ mm

2.2.11 Displacement under shear load

The characteristic displacements for short-term and quasi-permanent loading are specified for the shear load V in accordance with the following equation:

$$V = V_{Rk} / (\gamma_F \cdot \gamma_M) \quad [N] \quad (17)$$

with:

V_{Rk}	=	characteristic resistance
γ_F	=	1,4
γ_M	=	recommended partial safety factor for material acc. [1]

The displacements under short term shear loading (δ_{v0}) are evaluated from the corresponding shear tests with single anchors in concrete. The value derived shall correspond to the mean value.

The long term shear loading displacements $\delta_{v\infty}$ may be assumed to be equal to 1,5 times the value δ_{v0} .

Under shear loading the displacements might increase due to a gap between fixture and anchor. Therefore in the ETA shall be stated clearly if this gap is taken into account in the assessment.

The displacements (in mm) should be rounded up to zero or five on the first place after the decimal point.

2.2.12 Combined tension and shear load

For the verification of combined tension and shear load acc. CEN/TS 1992-4-2 [1], section 6.4.1.3, formula (49) the factor k_7 is used as follows:

$$k_7 = 2/3 \quad [-]$$

2.2.13 Reaction to fire

The product is considered to satisfy the requirements for performance class A1 of the characteristic reaction to fire in accordance with the EC Decision 96/603/EC without the need for testing on the basis of it fulfilling the conditions set out in that Decision and its intended use being covered by that Decision.

Therefore the performance of the product is class A1.

2.2.14 Resistance to fire

The fire resistance to steel failure due to tension load shall be determined acc. to EAD 330232-00-0601 [5], Section 2.2.13.

The fire resistance to pull-out failure due to tension load shall be determined acc. to EAD 330232-00-0601 [5], Section 2.2.14.

The fire resistance to steel failure due to shear load shall be determined acc. to EAD 330232-00-0601 [5], Section 2.2.15.

3 ASSESSMENT AND VERIFICATION OF CONSTANCY OF PERFORMANCE

3.1 System(s) of assessment and verification of constancy of performance to be applied

For the products covered by this EAD the applicable European legal act is: Decision 96/582/EC

The system is: 1

3.2 Tasks of the manufacturer

3.2.1 General

The cornerstones of the actions to be undertaken by the manufacturer of the product in the procedure of assessment and verification of constancy of performance are laid down in Table 3.1.

Table 3.1 Control plan for the manufacturer; cornerstones

No	Subject/type of control	Test or control method	Criteria	Minimum number of samples	Minimum frequency of control
Factory production control (FPC)					
1	Raw material and components: mechanical characteristics	Section 3.2.2	1)	all	Each delivery
2	Dimensions (diameter of reinforcing bar, diameter of head, thread diameter, overall length, thread length etc.) 4)	Measuring by caliper and/ or gauge or optical	1)	3 each size 2)	Per 10.000 studs or once per production week 3)
3	characteristic yield strength	EN ISO 6892-1: 2016 [2]	$f_{yk} \geq 500$ [N/mm ²]		
4	characteristic ratio tensile strength / yield strength		$(f_u/f_y)_k \geq 1,08$ (1,15) [-]		
5	characteristic strain at maximum force		$\epsilon_{uk} \geq 5,0$ (7,5) [%]		

1) according to the manufacturer technical file resp. control plan

2) each type of material

3) whichever criterion is the more rigorous

4) The geometrical characteristics according to Table 3.1 shall be determined by means of measuring. Possible tolerances as specified by the manufacturer shall be considered.

3.2.2 Raw material

The raw materials shall be subject to control and tests by the manufacturer before acceptance. Check of raw materials shall include control of the inspection documents presented by the supplies of the initial materials (comparison with nominal values).

The following certificate resp. test report should be agreed with the manufacturer ~~may only use raw materials with the following verifications~~ and recorded in Table 3.1:

Reinforcement bars: Material and material properties to be proved by an inspection certificate 3.1 according to EN 10204.

Components: Material and material properties to be proved by a specific test report 2.2 according to EN 10204.

3.3 Tasks of the notified body

The cornerstones of the actions to be undertaken by the notified body in the procedure of assessment and verification of constancy of performance for the product are laid down in Table 3.2.

Table 3.2 Control plan for the notified body; cornerstones

No	Subject/type of control	Test or control method	Criteria	Minimum number of samples	Minimum frequency of control
Initial inspection of the manufacturing plant and of factory production control					
1	Ascertain that the factory production control with the staff and equipment are suitable to ensure a continuous and orderly manufacturing of the mechanical fastener.	-	Laid down in control plan	-	1
Continuous surveillance, assessment and evaluation of factory production control					
2	Verifying that the system of factory production control and the specified automated manufacturing process are maintained taking account of the control plan.	-	Laid down in control plan	-	1/year

4 REFERENCE DOCUMENTS

As far as no edition date is given in the list of standards thereafter, the standard in its current version at the time of issuing the European Technical Assessment, is of relevance.

- | | | |
|-----|-------------------------------------|--|
| [1] | CEN/TS 1992-4:2009: | Design of Fastenings for Use in Concrete, Part 1: General; Part 2: Headed Fasteners. |
| [2] | EN ISO 6892-1:2016 | Metallic materials – Tensile testing – Part 1: Method of test at room temperature |
| [3] | Technical Report 048:
2016-08 | Details of tests for post-installed fasteners in concrete |
| [4] | EN 206-1:2000 | Concrete - Part 1: Specification, performance, production and conformity, |
| [5] | EAD 330232-00-0601 | Mechanical fasteners for use in concrete |
| [6] | Handbook of Statistical
Tables 3 | Owen, D.: Handbook of Statistical Tables 3, Addison/Wesley Publishing Company Inc., 1962 |
| [7] | Dissertation | Furche, J.: "Zum Trag- und Verschiebungsverhalten von Kopfbolzen bei zentrischem Zug", Universität Stuttgart |

ANNEX A DETAILS OF TESTS AND EVALUATION OF THE TEST RESULTS

A.1 General

For the tests to be carried out it is assumed that the anchor bolt of ribbed reinforcing steel is embedded in concrete and is used for general and steel to steel contact applications. The number of the tests can be kept very small, since sufficient test experience is available for bolts with a smooth shank and undercut anchors. The design method for metal anchors was also derived from these tests. The necessary tests at ribbed anchor bolts serve to check the calculated verifications which were derived from tests at smooth headed bolts. It is the aim to determine whether the behaviour of the anchor bolts with ribbed reinforcing steel falls within the range of the current experience gained from smooth head bolts.

A.2 Concrete

The tests shall be carried out in concrete of at least the strength class C20/25 according to EN 206-1:2000 [4]. The maximum aggregate size is 16 mm. The concrete specimens shall be produced in accordance with [4]. The concrete strength shall be determined according to TR 048 [3]. The tests shall be carried out on specimens under laboratory conditions.

A.3 Installation

The product shall be fixed with the formwork such, that it does not move during the laying of the reinforcement and the application and compaction of the concrete.

During the concrete placing care shall be taken, that the concrete is well compacted under the head of the bolt.

A.4 Steel tests

The steel tests have to be performed with the end product consisting of the anchor bolt with one washer and one nut. The anchor bolt shall be born on one end at the washer with nut and on the other end at the head of the anchor (Fig. A.1). The bearing shall be done on both sides with a plate with a hole. Both plates shall conform to Fig. A.2 and A.3

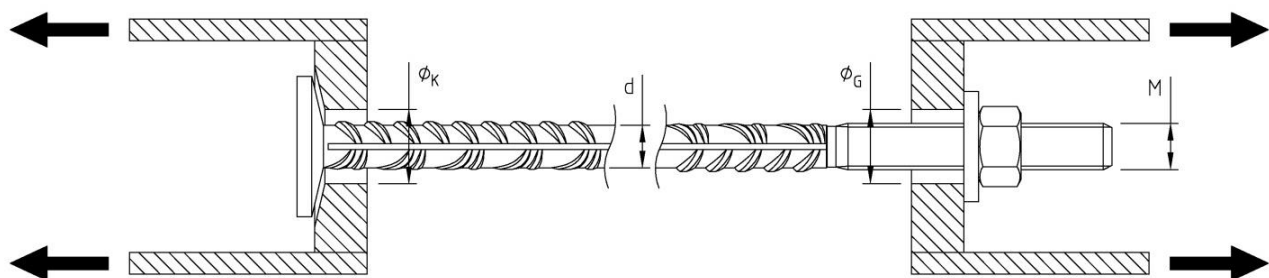

Fig. A.1: Sectional view of test rig for tension tests with bearing plates at both ends

Version A
Closed hole in plate

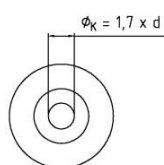
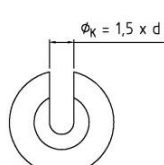

Fig. A.2: Top view of plate for head of the anchor bolt with two possible versions (anchor bolt not shown)

Version B
Open hole in plate



Version C
Open hole in plate

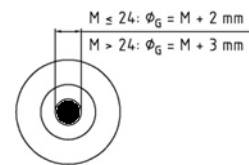

Fig. A.3: Top view of plate for thread of the anchor bolt (anchor bolt shown)

A.5 Tests

Table A.1 Required tests

No	Test	h_{ef} [mm]	Concrete strength	Number of tests	Anchor bolt diameter [mm]		
					Ø 12-16 small	Ø 20-25 medium	Ø > 25 max
1	centric tension single fastening pure steel test (thread and head)	-	-	5 each	X	X	X
2	centric tension, unconfined single fastening without influence of spacing and edge distance	≥ 160	C20/25	≥ 5	-	-	X
3	centric tension, unconfined single fastening at a corner ¹⁾ $c_1 = c_2 \leq 80$ mm	≥ 160	C20/25	≥ 4	-	X	-
4	torque test to concrete failure double fastening at the edge ²⁾ $c_{min}, s_{min}, h_{min}$	-	C20/25	≥ 5	X	X	X
5	torque test to steel failure single fastening ³⁾	-	C20/25	5 each	X	X	X
6	Shear test single fastening without influence of spacing and edge distance ⁴⁾	≥ 160	C50/60	5 each	X	X	X

1) optional for the determination of C_{crsp} , s_{crsp} and h_{min} , else reinforcement to resist splitting forces acc. CEN/TS 1992-4-2:2009, section 6.2.6.2 is placed close to the anchorage

2) optional only for intended use acc. Fig. 2 a) for the determination of c_{min} , s_{min} and h_{min} , else reinforcement to resist splitting forces acc. CEN/TS 1992-4-2:2009, section 6.2.6.2 is placed close to the anchorage

3) optional for the determination of prestressed tension Force N_v , else friction factor $k=0,1$

4) optional for the determination of $V_{Rk,s}$, else calculation acc. section 2.2.8

For the individual tests the maximum loads shall be determined by indicating the failure mode. The load/displacement curves shall be recorded.

ANNEX B GENERAL ASSESSMENT METHODS

B.1 Conversion of failure loads to nominal strength

The conversion of failure loads shall be done according to Equation B.1 to B.2 depending on the failure mode.

Concrete failure	$F_{u,c} = F_{u,test} \cdot \left(\frac{f_c}{f_{c,test}} \right)^{0,5}$	with $\frac{f_c}{f_{c,test}} \leq 1,0$	(B.1)
Steel failure	$F_{u,s} = F_{u,test} \frac{f_u}{f_{u,test}}$		(B.2)

B.2 Establishing 5 % fractile

The 5 %-fractile of the ultimate loads measured in a test series is to be calculated according to statistical procedures for a confidence level of 90 %. If a precise verification does not take place, a normal distribution and an unknown standard deviation of the population shall be assumed.

$$F_{u,5\%} = F_{u,m}(1 - k_s \cdot cv_F) \quad (\text{B.9})$$

$$F_{u,95\%} = F_{u,m}(1 + k_s \cdot cv_F) \quad (\text{B.10})$$

e.g.: n = 5 tests: $k_s = 3,40$
n = 10 tests: $k_s = 2,57$

Note 1: The confidence level of 90% is defined for characteristic resistance of fasteners in prEN 1992-4 and is therefore used for the assessment in this EAD.