

## EUROPEAN ASSESSMENT DOCUMENT

EAD 180022-00-0704

May 2018

# PREFABRICATED PLASTIC FITTING MADE FROM RECYCLED WASTE PLASTICS AND DESIGNED FOR DRAINAGE OF LAND AND CIVIL ENGINEERING

The reference title and language for this EAD is English. The applicable rules of copyright refer to the document elaborated in and published by EOTA.

This European Assessment Document (EAD) has been developed taking into account up-to-date technical and scientific knowledge at the time of issue and is published in accordance with the relevant provisions of Regulation (EU) No 305/2011 as a basis for the preparation and issuing of European Technical Assessments (ETA).

## Contents

<b>1</b>	<b>Scope of the EAD .....</b>	<b>4</b>
1.1	Description of the construction product	4
1.2	Information on the intended use(s) of the construction product	5
1.2.1	Intended use(s).....	5
1.2.2	Working life/Durability.....	5
<b>2</b>	<b>Essential characteristics and relevant assessment methods and criteria .....</b>	<b>6</b>
2.1	Essential characteristics of the product	6
2.2	Methods and criteria for assessing the performance of the product in relation to essential characteristics of the product	7
2.2.1	Reaction to fire .....	7
2.2.2	Content, emission and/or release of dangerous substances .....	7
2.2.3	Apparent density.....	8
2.2.4	Flexural strength.....	8
2.2.5	Resistance to low temperature.....	8
2.2.6	Resistance to heat.....	9
2.2.7	Resistance to exposure with the combination of UV radiation, elevated temperature and water .....	9
2.2.8	Effects of immersion in liquid chemicals .....	9
2.2.9	Watertightness.....	10
<b>3</b>	<b>Assessment and verification of constancy of performance.....</b>	<b>11</b>
3.1	System(s) of assessment and verification of constancy of performance to be applied	11
3.2	Tasks of the manufacturer	11
3.3	Tasks of the notified body	12
<b>4</b>	<b>Reference documents .....</b>	<b>14</b>

# 1 SCOPE OF THE EAD

## 1.1 Description of the construction product

The EAD applies to the prefabricated plastic fitting made from recycled waste plastics and designed for drainage of land and civil engineering. The plastic material is isotropic (properties do not depend on its orientation).

The mixed waste plastics are used for production after sorting of municipal collection with predominant component PE (ca. 55%), PP (ca. 35%) and other plastics (PET, PS). Remaining 10% form additives (sorted recycled PE and sorted recycled PP).

Input material is partly washed. The product is 100% recyclable.

Plastic fitting forms a good substitute for commonly used concrete fittings due to its flexibility and strength.

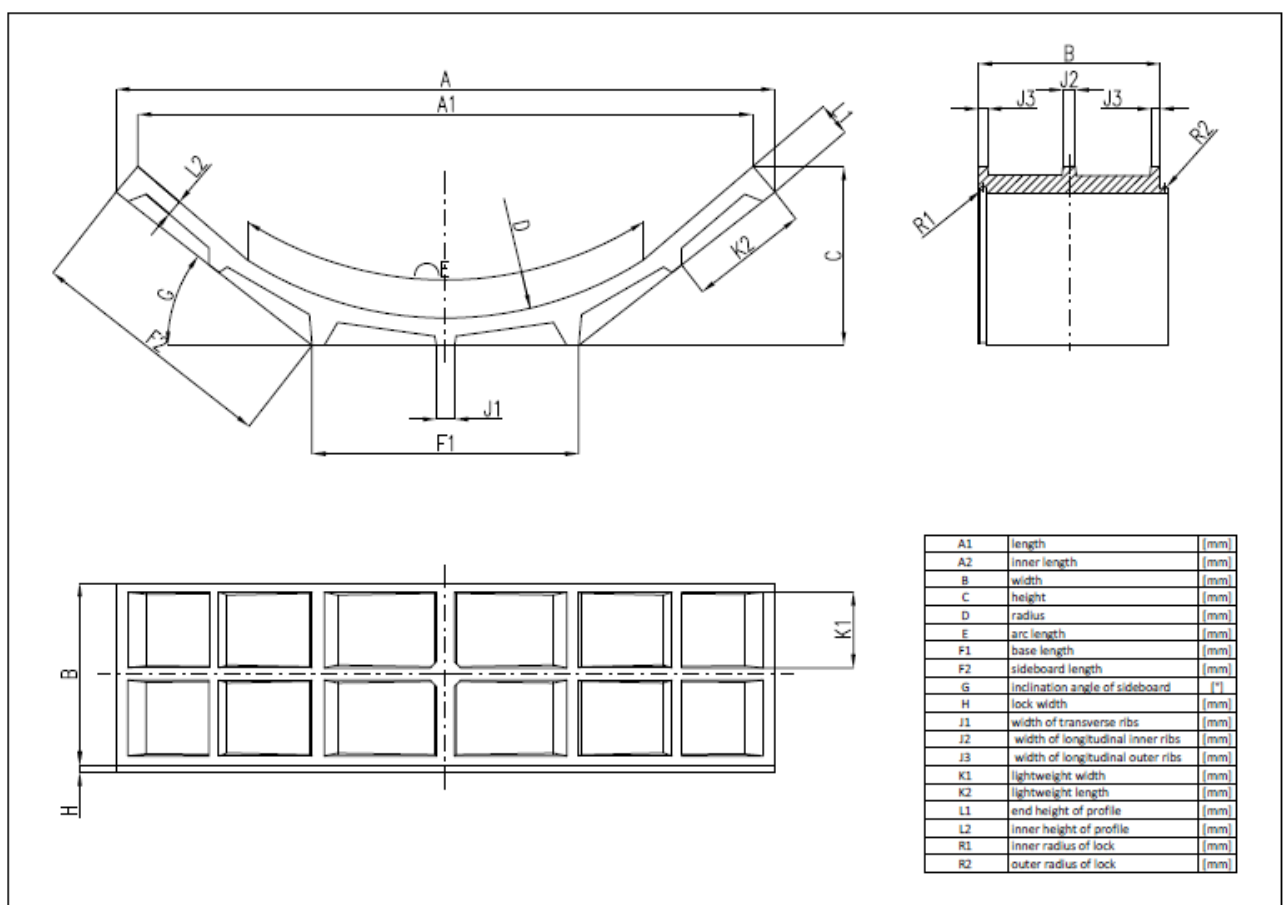

Figure No. 1: Drawing of the plastic fitting with description of geometry

### Minimal requirements:

Inner radius of lock R1	5 mm
Outer radius of lock R2	4 mm
Radius D	605 mm

The mounting conditions must fulfil related regulations for the field of applications.

Ancillary products which can be a part of installation provisions or in the framework for determination performances are not covered by this EAD.

The product is not covered by a harmonised European standard (hEN).

Concerning product packaging, transport, storage, maintenance, replacement and repair it is the responsibility of the manufacturer to undertake the appropriate measures and to advise his clients on the transport, storage, maintenance, replacement and repair of the product as he considers necessary.

It is assumed that the product will be installed according to the manufacturer's instructions or (in absence of such instructions) according to the usual practice of the building professionals.

Relevant manufacturer's stipulations having influence on the performance of the product covered by this European Assessment Document shall be considered for the determination of the performance and detailed in the ETA.

## **1.2 Information on the intended use(s) of the construction product**

### **1.2.1 Intended use(s)**

The prefabricated plastic fitting made from recycled waste plastics is designed for drainage of land and civil engineering.

### **1.2.2 Working life/Durability**

The assessment methods included or referred to in this EAD have been written based on the manufacturer's request to take into account a working life of the prefabricated plastic fitting for the intended use of 25 years when installed in the works /provided that the prefabricated plastic fitting is subject to appropriate installation (see 1.1)/. These provisions are based upon the current state of the art and the available knowledge and experience.

When assessing the product the intended use as foreseen by the manufacturer shall be taken into account. The real working life may be, in normal use conditions, considerably longer without major degradation affecting the basic requirements for works<sup>1</sup>.

The indications given as to the working life of the construction product cannot be interpreted as a guarantee neither given by the product manufacturer or his representative nor by EOTA when drafting this EAD nor by the Technical Assessment Body issuing an ETA based on this EAD, but are regarded only as a means for expressing the expected economically reasonable working life of the product.

---

<sup>1</sup> The real working life of a product incorporated in a specific works depends on the environmental conditions to which that works is subject, as well as on the particular conditions of the design, execution, use and maintenance of that works. Therefore, it cannot be excluded that in certain cases the real working life of the product may also be shorter than referred to above.

## 2 ESSENTIAL CHARACTERISTICS AND RELEVANT ASSESSMENT METHODS AND CRITERIA

### 2.1 Essential characteristics of the product

Table 1 shows how the performance of the prefabricated plastic fitting is assessed in relation to the essential characteristics.

**Table 1 Essential characteristics of the product and methods and criteria for assessing the performance of the product in relation to those essential characteristics**

No	Essential characteristic	Assessment method	Type of expression of product performance (level, class, description)
<b>Basic Works Requirement 2: Safety in case of fire</b>			
1	Reaction to fire	Cl. 2.2.1	Class
<b>Basic Works Requirement 3: Hygiene, health and the environment</b>			
2	Content, emission and/or release of dangerous substances	Cl. 2.2.2	Level
<b>Basic Works Requirement 4: Safety and accessibility in use</b>			
3	Apparent density	Cl. 2.2.3	Level $\rho$ [kg/m <sup>3</sup> ]
4	Flexural strength	Cl. 2.2.4	Level $\sigma_{fM}$ [MPa]
5	Resistance to low temperature -flexural strength at (-20 ± 2) °C and relative humidity (50±5)°C	Cl. 2.2.5	Level $\sigma_{fM,-20}$ [MPa]
6	Resistance to heat -flexural strength at (40 ± 2) °C and relative humidity (50±5)°C -flexural strength at (70 ± 2) °C and relative humidity (50±5)°C	Cl. 2.2.6	Level $\sigma_{fM,40}$ [MPa] Level $\sigma_{fM,70}$ [MPa]
7	Resistance to exposure to the combination of UV radiation, elevated temperature and water -flexural strength after exposure	Cl. 2.2.7	Level $\sigma_{fM,UV}$ [MPa]
8	Effects of immersion in liquid chemicals -volume change after 4 weeks -flexural properties after 4 weeks -change in mass after 7 days	Cl. 2.2.8	Level Q[%] $\sigma_{fM,im}$ [MPa] c[%]
9	Watertightness	Cl. 2.2.9	Level Pass/Fail

## 2.2 Methods and criteria for assessing the performance of the product in relation to essential characteristics of the product

All tests are to be performed at standard laboratory environment ( $23 \pm 2$  °C and RH ( $50 \pm 10$ ) %) according to EN ISO 291, if relevant test procedure does not specify other conditions. Test specimens are to be conditioned in relevant environment for 24 hours before the test if the test procedure does not specify otherwise.

### 2.2.1 Reaction to fire

The prefabricated plastic fitting is to be tested according to EN ISO 11925-2 using the test method(s) referred to in 13501-1 and relevant for the corresponding reaction to fire class.

The prefabricated plastic fitting shall be classified according to Commission Delegated Regulation (EU) No. 2016/364.

The class of reaction to fire of the product is given in the ETA.

### 2.2.2 Content, emission and/or release of dangerous substances

The performance of the product related to the emissions and/or release and, where appropriate, the content of dangerous substances will be assessed on the basis of the information provided by the manufacturer<sup>2</sup> after identifying the release scenarios (in accordance with EOTA TR 034) taking into account the intended use of the product and the Member States where the manufacturer intends his product to be made available on the market.

The identified intended release scenarios for this product and intended use with respect to dangerous substances are:

#### Use category:

S/W1: Product with direct contact to soil, ground- and surface water.

For the intended use covered by the release scenario S/W1 the performance of the prefabricated plastic fitting concerning leachable substances has to be assessed. A leaching test with subsequent eluate analysis must take place, each in duplicate. Leaching tests of the prefabricated plastic fitting are conducted according to CEN/TS 16637-2. The leachant shall be pH-neutral demineralised water and the ratio of liquid volume to surface area must be  $(80 \pm 10)$  l/m<sup>2</sup>.

---

<sup>2</sup> The manufacturer may be asked to provide to the TAB the REACH related information which he must accompany the DoP with (cf. Article 6(5) of Regulation (EU) No 305/2011).

The manufacturer is **not** obliged:

- to provide the chemical constitution and composition of the product (or of constituents of the product) to the TAB, or
- to provide a written declaration to the TAB stating whether the product (or constituents of the product) contain(s) substances which are classified as dangerous according to Directive 67/548/EEC and Regulation (EC) No 1272/2008 and listed in the "Indicative list on dangerous substances" of the SGDS.

Any information provided by the manufacturer regarding the chemical composition of the products may not be distributed to EOTA or to TABs.

Test samples of the prefabricated plastic fitting shall be prepared in accordance with Cl. 8.2(6) of CEN/TS 16637-2.

In eluates of "6 hours" and "64 days", the following biological tests shall be conducted:

- Acute toxicity test with *Daphnia magna* Straus according to EN ISO 6341
- Toxicity test with algae according to ISO 15799
- Luminescent bacteria test according to EN ISO 11348-1, EN ISO 11348-2 or EN ISO 11348-3

For each biological test, EC<sub>20</sub>-values shall be determined for dilution ratios 1:2, 1:4, 1:6, 1:8 and 1:16.

If the parameter TOC (= Total Organic Carbon) is higher than 10 mg/l, the following biological tests shall be conducted with the eluates of "6 hours" and "64 days" eluates:

- Biological degradation according to OECD Test Guideline 301 part A, B or E.

Determined toxicity in biological tests must be expressed as EC<sub>20</sub>-values for each dilution ratio. Maximum determined biological degradability must be expressed as "...% within ...hours/days". The respective test methods for analysis must be specified.

### 2.2.3 Apparent density

The determination of apparent density is tested according to EN ISO 845.

At least 5 test specimens shall be tested.

Conditioning of test specimens shall be performed for at least 16 hours under standard conditions according to ISO 291 at (23±2) °C and relative humidity (50±10) °C.

Express the result of  $\rho$  [kg/m<sup>3</sup>] as an arithmetic mean of the obtained values.

Apparent density  $\rho$  [kg/m<sup>3</sup>] with the accuracy 0.1 kg/m<sup>3</sup> is given in the ETA

### 2.2.4 Flexural strength

The flexural strength of the prefabricated plastic fitting shall be determined on at least 5 test specimens by testing in accordance with the test method A given in EN ISO 178, Cl. 8.7.

Shape and dimensions of test specimen shall be selected according to EN ISO 178, Cl. 6.1.3. Preparation and control of test specimens shall be taken according to EN ISO 178, Cl. 6.3 to 6.5.

Express the result of  $\sigma_{fM}$  [MPa] as an arithmetic mean of the obtained values.

Flexural strength  $\sigma_{fM}$  [MPa] is given in the ETA.

### 2.2.5 Resistance to low temperature

The flexural strength  $\sigma_{fM,-20}$  after the exposure of the conditioned at least 6 test specimens shall be determined by testing in accordance with Cl.2.2.4.

Conditioning of test specimens for determination of flexural strength is performed at the temperature

(-20 ± 2) °C and relative humidity (50 ± 5) % for (24 ± 1) hours.

Testing is performed under normal conditions according to Cl. 2.2.4 without delay after completion of conditioning.

Flexural strength  $\sigma_{fM,-20}$  [MPa] after the exposure is given in the ETA.



## 2.2.6 Resistance to heat

### 2.2.6.1 Resistance to heat at $(40 \pm 2)$ °C and relative humidity $(50 \pm 5)$ %

The flexural strength  $\sigma_{fM,40}$  after the exposure to heat of the conditioned at least 6 test specimens shall be determined by testing in accordance with Cl.2.2.4.

Conditioning of test specimens for determination of flexural strength is performed at the temperature  $(40 \pm 2)$  °C and relative humidity  $(50 \pm 5)$  % for  $(48 \pm 1)$  hours.

Testing is performed under normal conditions according to Cl. 2.2.4 without delay after completion of conditioning. Flexural strength  $\sigma_{fM,40}$  [MPa] after the exposure is given in the ETA.

### 2.2.6.2 Resistance to heat at $(70 \pm 2)$ °C and relative humidity $(50 \pm 5)$ %

The flexural strength  $\sigma_{fM,h70}$  after the exposure to heat of the conditioned at least 6 test specimens shall be determined by testing in accordance with Cl.2.2.4.

Conditioning of test specimens for determination of flexural strength is performed at the temperature  $(70 \pm 2)$  °C and relative humidity  $(50 \pm 5)$  % for  $(48 \pm 1)$  hours.

Testing is performed under normal conditions according to Cl. 2.2.4 without delay after completion of conditioning.

Flexural strength  $\sigma_{fM,70}$  [MPa] after the exposure is given in the ETA.

## 2.2.7 Resistance to exposure with the combination of UV radiation, elevated temperature and water

The resistance to exposure with the combination of UV radiation, elevated temperature and water is determined according to EN 1297.

Required number of cycles: 60

The flexural strength after the exposure of the prefabricated plastic fitting shall be determined on at least 6 test specimens by testing in accordance with Cl.2.2.4.

Flexural strength  $\sigma_{fM,c}$  [MPa] after the exposure is given in the ETA.

## 2.2.8 Effects of immersion in liquid chemicals

### 2.2.8.1 Volume change and flexural strength after 4 weeks of immersion in liquid chemicals

Effects of immersion (volume change and flexural strength) in liquid chemicals: water, automotive oil, gasoline and naphtha shall be determined according to EN ISO 175.

At least 3 test specimens for each testing liquid shall be prepared according to Table 2 of EN ISO 178 with nominal thickness(h)  $20 \text{ mm} < h \leq 35 \text{ mm}$  and width  $(35 \pm 0.5) \text{ mm}$  and tested according to Cl.4.6 of EN ISO 175.

Conditioning of test specimens shall be performed according to Cl. 4.5 of EN ISO 175.

#### Test conditions:

Test temperature:  $(23 \pm 2)$  °C

Immersion time: 4 weeks

### 2.2.8.1.1 Volume change after 4 weeks of immersion in liquid chemicals

Determination of volume change after 4 weeks of immersion in liquid chemicals shall be evaluated according to Cl. 5.5.1.8 of EN ISO 175 and using the formula stated in Cl.5.5.2.1 of EN ISO 175

Express the result of percentage change  $Q$  [%] as an arithmetic mean of the three obtained values.

Percentage change  $Q$  [%] in volume for each liquid shall be given in the ETA.

#### 2.2.8.1.2 Flexural strength after 4 weeks of immersion in liquid chemicals

Flexural strength after 4 weeks of immersion in liquid chemicals shall be tested according to Cl.2.2.4.

Flexural strength  $\sigma_{fM, l}$  [MPa] is given in the ETA.

#### 2.2.8.2 Absorption of liquid chemicals

The absorption by immersion for 7 days in water, automotive oil, gasoline and naphtha is determined at 23°C in accordance with using the testing procedure of method A, EN ISO 62.

At least 3 test specimens for each testing liquid shall be prepared in accordance with Cl. 5.6. of EN ISO 62 and tested.

Percentage change in mass  $c$  relative to the initial mass is calculated on the basis of the first formula stated in Cl. 7.1 of EN ISO 62

Express the result of percentage change  $c$  [%] as an arithmetic mean of the three obtained values.

Percentage change  $c$  [%] in mass for each liquid shall be given in the ETA.

### 2.2.9 Watertightness

The watertightness of the prefabricated plastic fitting is determined by testing in accordance with the test method given in Cl. 7.5.1 of EN 1433 at the temperature  $(23 \pm 2)$  °C.

At least 1 test specimen shall be tested.

The evaluation of watertightness Pass/Fail is given in the ETA.

### 3 ASSESSMENT AND VERIFICATION OF CONSTANCY OF PERFORMANCE

#### 3.1 System(s) of assessment and verification of constancy of performance to be applied

For the products covered by this EAD the applicable European legal act is: Decision 2015/1959/EC.

The AVCP system is: 3

In addition, with regard to reaction to fire for products covered by this EAD the applicable European legal act is: Decision 2015/1959/EC.

The applicable AVCP systems are:

- 1 for products/materials for which a clearly identifiable stage in the production process results in any improvement of the reaction to fire performance (e.g. an addition of fire retardants or a limiting of organic material)
- 3 in regular case
- 4 for products/materials that do not require to be tested for reaction to fire

#### 3.2 Tasks of the manufacturer

The cornerstones of the actions to be undertaken by the manufacturer of the prefabricated plastic fitting made from recycled waste plastics in the procedure of assessment and verification of constancy of performance are laid down in Table 2.

**Table 2 Control plan for the manufacturer; cornerstones**

No	Subject/type of control (product, raw/constituent material, component - indicating characteristic concerned)	Test or control method	Criteria, if any	Minimum number of samples	Minimum frequency of control
<b>Factory production control (FPC) [including testing of samples taken at the factory in accordance with a prescribed test plan]</b>					
1	Reaction to fire	Cl. 2.2.1	Control plan	1	every batch of raw material
2	Apparent density	Cl. 2.2.3	Control plan	5	at a modification of production process
3	Flexural strength	Cl. 2.2.4	Control plan	5	at a modification of production process
4	Resistance to low temperature	Cl. 2.2.5	Control plan	5	at a modification of production process

No	Subject/type of control (product, raw/constituent material, component - indicating characteristic concerned)	Test or control method	Criteria, if any	Minimum number of samples	Minimum frequency of control
5	Resistance to heat	Cl. 2.2.6	Control plan	5	at a modification of production process
6	Resistance to exposure to the combination of UV radiation, elevated temperature and water	Cl. 2.2.7	Control plan	5	at a modification of production process
7	Effects of immersion in liquid chemicals	Cl. 2.2.8	Control plan	3	at a modification of production process
8	Watertightness	Cl. 2.2.9	Control plan	1	at a modification of production process

### 3.3 Tasks of the notified body

The cornerstones of the actions to be undertaken by the notified body in the procedure of assessment and verification of constancy of performance for the prefabricated plastic fitting made from recycled waste plastics are laid down in Table 3.

**Table 3 Control plan for the notified body; cornerstones**

No	Subject/type of control	Test or control method	Criteria, if any	Minimum number of samples	Minimum frequency of control
<b>Initial inspection of the manufacturing plant and of factory production control</b> (for system 1 only)					
1	Reaction to fire	Cl. 2.2.1	Classified according to EN 13501-1	1	Annually
<b>Continuous surveillance, assessment and evaluation of factory production control</b> (for system 1 only)					
..2.	Reaction to fire	Cl. 2.2.1	Classified according to EN 13501-1	1	Annually



## 4 REFERENCE DOCUMENTS

As far as no edition date is given in the list of standards thereafter, the standard in its current version at the time of issuing the European Technical Assessment, is of relevance.

Regulation (EC) No. 1907/2006 of the European Parliament and of the Council of 18 December 2006 concerning the Registration, Evaluation, Authorization and Restriction of Chemicals (REACH), establishing a European Chemicals Agency as amended

Commission Delegated Regulation (EU) No. 2016/364 of 1 July 2015 on the classification of the reaction to fire performance of construction products pursuant to Regulation (EU) No. 305/2011 of the European Parliament and of the Council

EN ISO 291 Plastics - Standard atmospheres for conditioning and testing

EN ISO 845 Cellular plastics and rubbers - Determination of apparent density

EN ISO 178 Plastics - Determination of flexural properties

EN 1122 Plastics - Determination of cadmium - Wet decomposition method

EN 1297 Flexible sheets for waterproofing - Bitumen, plastic and rubber sheets for roof waterproofing - Method of artificial ageing by long term exposure to the combination of UV radiation, elevated temperature and water

EN ISO 62 Plastics - Determination of water absorption (ISO 62:2008)

EN ISO 175 Plastics - Methods of test for the determination of the effects of immersion in liquid chemicals (ISO 175:2010)

EN 1433 Drainage channels for vehicular and pedestrian areas - Classification, design and testing requirements, marking and evaluation of conformity

EN 13501-1 Fire classification of construction products and building elements - Part 1: Classification using test data from reaction to fire tests

EN 13238 Reaction to fire tests for building products - Conditioning procedures and general rules for selection of substrates

EN ISO 11925-2 Reaction to fire tests - Ignitability of building products subjected to direct impingement of flame - Part 2: Single-flame source test

CEN/TS 16637-2 Construction products - Assessment of release of dangerous substances - Part 2: Horizontal dynamic surface leaching test

EN ISO 6341 Water quality - Determination of the inhibition of the mobility of *Daphnia magna* Straus (Cladocera, Crustacea) - Acute toxicity test

ISO 15799 Soil quality – Guidance on the ecotoxicological characterization of soils and soil materials

EN ISO 11348-1 Water quality - Determination of the inhibitory effect of water samples on the light emission of *Vibrio fischeri* (Luminescent bacteria test) - Part 1: Method using freshly prepared bacteria

EN ISO 11348-2 Water quality - Determination of the inhibitory effect of water samples on the light emission of *Vibrio fischeri* (Luminescent bacteria test) - Part 2: Method using liquid-dried bacteria

EN ISO 11348-3 Water quality - Determination of the inhibitory effect of water samples on the light emission of *Vibrio fischeri* (Luminescent bacteria test) - Part 3: Method using freeze-dried bacteria

EOTA TR 034 General BWR 3 Checklist for EADs/ETAs – Dangerous substances

OECD Guideline for testing of chemicals 301