



www.eota.eu

EAD 340292-00-0303

March 2019

European Assessment Document for

Earthquake-resistant kits composed of steel-concrete composite beams, columns and beam-column joints



The reference title and language for this EAD is English. The applicable rules of copyright refer to the document elaborated in and published by EOTA.

This European Assessment Document (EAD) has been developed taking into account up-to-date technical and scientific knowledge at the time of issue and is published in accordance with the relevant provisions of Regulation (EU) No 305/2011 as a basis for the preparation and issuing of European Technical Assessments (ETA).

Contents

1	Scope of the EAD	4
1.1	Description of the construction product	4
1.2	Information on the intended use(s) of the construction product	6
1.2.1	Intended use(s).....	6
1.2.2	Working life/Durability.....	6
1.3	Specific terms used in this EAD	6
1.3.1	Specific terms.....	6
1.3.2	Symbols.....	7
2	Essential characteristics and relevant assessment methods and criteria	8
2.1	Essential characteristics of the product	8
2.2	Methods and criteria for assessing the performance of the product in relation to essential characteristics of the product	10
2.2.1	Resistance of the truss element in the first phase (beam).....	10
2.2.2	Flexural strength of the composite steel-concrete beam in the second phase.....	15
2.2.3	Shear strength of the composite steel-concrete beam in the second phase.....	17
2.2.4	Ductility of the beam element in the second phase.....	18
2.2.5	Combined axial force-bending moment resistance of the column element in the first phase.....	19
2.2.6	Combined axial force-bending moment resistance of the column element in the second phase.....	19
2.2.7	Shear strength of columns.....	20
2.2.8	Ductility of column elements.....	21
2.2.9	Cyclic behaviour of the earthquake-resistant kit.....	22
2.2.10	Fire resistance of the beam.....	23
2.2.11	Fire resistance of the column.....	23
3	Assessment and verification of constancy of performance	25
3.1	System(s) of assessment and verification of constancy of performance to be applied	25
3.2	Tasks of the manufacturer	26
3.3	Tasks of the notified body	27
4	Reference documents	28
ANNEX A	ULTIMATE LOAD OF STEEL LATTICE GIRDER BEAM IN THE FIRST PHASE	29
ANNEX B	ASSESSMENT OF THE FLEXURAL AND THE SHEAR STRENGTH OF THE BEAM IN THE SECOND PHASE	32
ANNEX C	ASSESSMENT OF THE COMBINED AXIAL FORCE-BENDING MOMENT RESISTANCE AND SHEAR STRENGTH OF THE COLUMN ELEMENT	34
ANNEX D	TEST METHOD FOR THE ASSESSMENT OF THE CYCLIC BEHAVIOUR OF THE EARTHQUAKE-RESISTANT KIT	37

1 SCOPE OF THE EAD

1.1 Description of the construction product

The earthquake-resistant kits composed of steel-concrete composite beams, columns and beam-column joints (in the following referred to as “earthquake-resistant kit(s)”) are self-supporting construction systems, composed of beams, columns and beam-column joints, not requiring provisional structures during the transitional phases of the construction.

The concrete to be cast in situ is not part of the kits.

The columns are hollow steel elements (Figure 1.1.1), with square, circular or rectangular cross-section; other section shapes can be designed both with commercial or welded sections. The columns are provided with internal steel reinforcement and are filled with concrete cast in situ. A base and top plate are also provided in order to connect the column to the foundation or to other beam or column elements. The external hollow element consists of hot finished or cold formed welded hollow sections of non-alloy and fine grain steels or also of tempered steel and stainless steel. The connection plates are made of hot rolled steel.

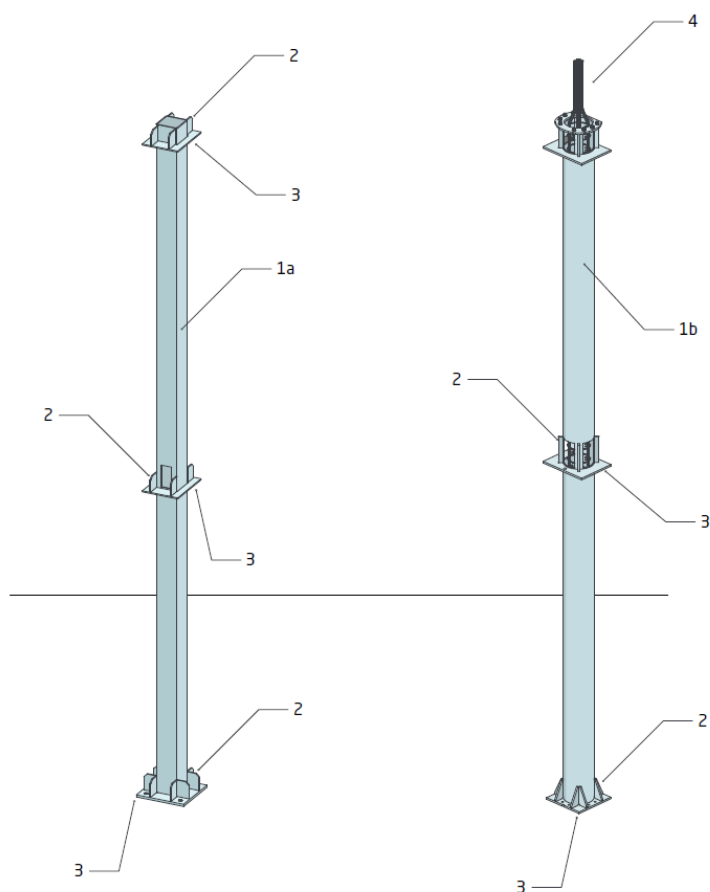

Figure 1.1.1: Multi-story columns: external hollow steel elements with square (1a) or circular (1b) cross-section; (2) additional welded steel reinforcements outside the hollow steel element; (3) base and top steel plates (welded with the other parts), provided in order to connect the column to the foundation or to other beam or column elements; (4) internal reinforcement cage of deformed steel bars

The assessment methods as given in this EAD are based on the assumption that the beams are made of one or more steel trusses welded to each other in continuous way in accordance with the process defined in EN ISO 4063¹. The bottom chord of the truss elements is made of a planar or cold formed steel plate

¹ All undated references to standards in this EAD are to be understood as references to the dated versions listed in chapter 4.

(Figure 1.1.2). After installation, the beams are completed with concrete cast in situ. Hot rolled steel, ribbed steel, tempered steel or stainless steel are used for beams.

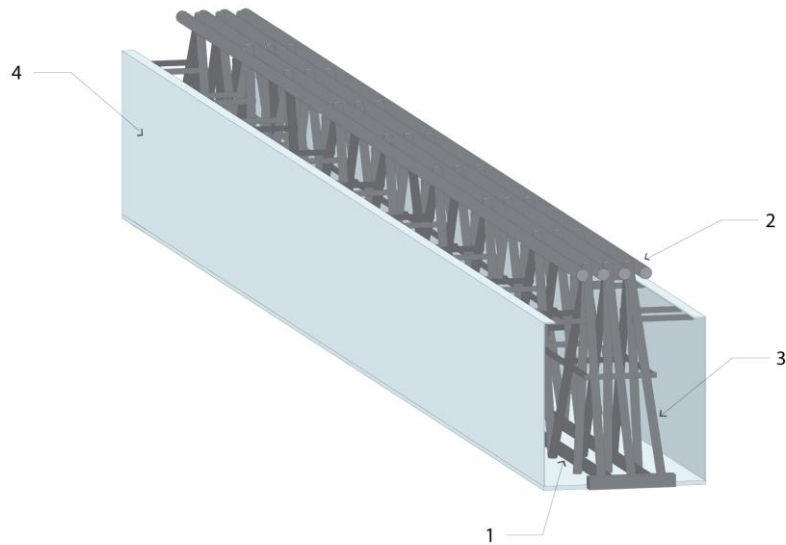

Figure 1.1.2: Beams in first phase (see 1.3.1): (1) bottom chord of the truss elements made of a planar or cold formed steel plate, (2) Upper chord of the truss elements, (3) Web diagonal elements, (4) Welded steel plates as formwork for the concrete casting

The joint between beam and column is constituted by loose reinforcing bars as in Figure 1.1.3.

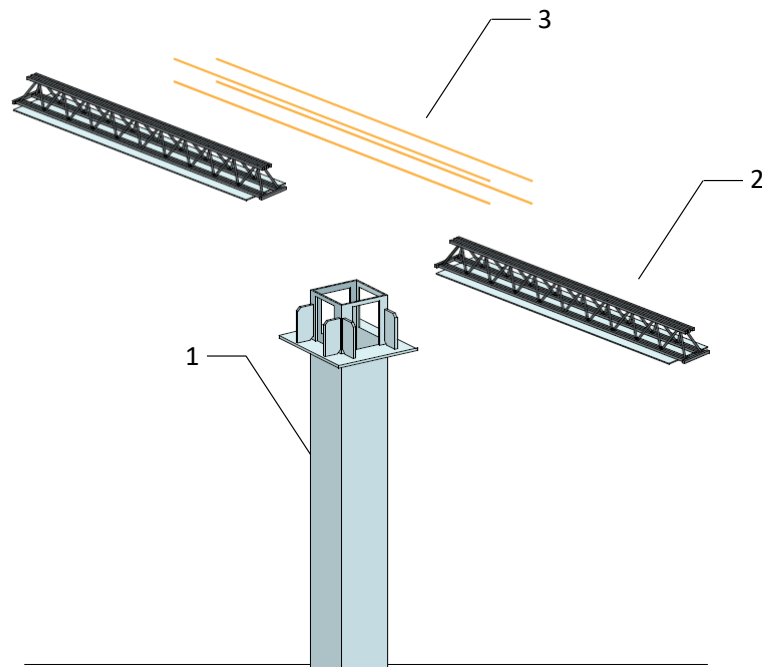

Figure 1.1.3: Schematic view of a joint: (1) column, (2) beam and (3) additional loose reinforcing bars.

The product is not covered by a harmonised European standard (hEN).

Concerning product packaging, transport, storage, maintenance, replacement and repair, it is the responsibility of the manufacturer to undertake the appropriate measures and to advise his clients on the transport, storage, maintenance, replacement and repair of the product as he considers necessary.

It is assumed that the product will be installed according to the manufacturer's instructions or (in absence of such instructions) according to the usual practice of the building professionals.

Relevant manufacturer's stipulations, e.g., with regard to the intended end use conditions, having influence on the performance of the product covered by this European Assessment Document shall be considered for the determination of the performance and detailed in the ETA as long as the details of the assessment methods as laid down in this EAD are respected.

1.2 Information on the intended use(s) of the construction product

1.2.1 Intended use(s)

The earthquake-resistant kit is intended to be used as load-bearing or earthquake-resistant frame or both in civil and industrial buildings and infrastructures, when completed with cast in situ concrete.

1.2.2 Working life/Durability

The assessment methods included or referred to in this EAD have been written based on the manufacturer's request to take into account a working life of the earthquake-resistant kit for the intended use of 50 years when installed in the works (provided that the earthquake-resistant kits are subject to appropriate installation (see 1.1)). These provisions are based upon the current state of the art and the available knowledge and experience.

When assessing the product, the intended use as foreseen by the manufacturer shall be taken into account. The real working life may be, in normal use conditions, considerably longer without major degradation affecting the basic requirements for works².

The indications given as to the working life of the construction product cannot be interpreted as a guarantee neither given by the product manufacturer or his representative nor by EOTA when drafting this EAD nor by the Technical Assessment Body issuing an ETA based on this EAD, but are regarded only as a means for expressing the expected economically reasonable working life of the product.

1.3 Specific terms used in this EAD

1.3.1 Specific terms

<i>Beam type</i>	Beam element to be included in the ETA identified by material and dimensions of the steel truss element and formwork steel plate.
<i>Column type</i>	Column element to be included in the ETA identified by material and dimensions of the hollow steel element, internal steel reinforcement dimensions and positioning.
<i>First phase</i>	Phase of the construction process during which the earthquake-resistant kits are composed of steel beams and steel columns not completed with concrete cast in situ.
<i>Second phase</i>	Phase of the construction process during which beams and columns of the earthquake-resistant kits are completed with concrete cast in situ and become steel-concrete composite elements.

² The real working life of a product incorporated in a specific work depends on the environmental conditions to which that work is subject, as well as on the particular conditions of the design, execution, use and maintenance of that works. Therefore, it cannot be excluded that in certain cases the real working life of the product may also be shorter than referred to above.

1.3.2 Symbols

In addition to the symbols defined in EN 1992-1-1, EN 1992-1-2, EN 1993-1-1, EN 1993-1-8, EN 1994-1-1, EN 1994-1-2 and EN 1998-1, the following symbols are used in the EAD.

$F_{b,1}$	[kNm; kN, kN, kN, kN] or [kN]	Resistance of the truss element in the first phase
M_e	[kNm]	Buckling resistance moment of the beam in the first phase
N_p	[kN]	Maximum load value leading to the instability of the top chord
N_t	[kN]	Maximum load value leading to the instability of the inclined strut
N_e	[kN]	Ultimate yielding resistance of truss elements
R_w	[kN]	Truss welds maximum strength
$M_{b,2}$	[kNm]	Flexural strength of the beam in the second phase
$V_{b,2}$	[kN]	Shear strength of the beam in the second phase
$\mu_{b,2}$	[-]	Curvature ductility factor of the beam in the second phase
$M_{c,1}, N_{c,1}$	[kNm; kN]	Point defining the M-N limit domain of the column in the first phase
$M_{c,2,X}, N_{c,2,X}$	[kNm; kN]	Point defining the M-N limit domain of the column in the second phase. The "X" symbol stands for one of the four letters (A, B, C, D) of the four points limit domain.
$V_{c,2}$	[kN]	Shear strength of column in the second phase
$\mu_{c,2}$	[-]	Displacement ductility factor of the beam in the second phase
$V_{y,t}$	[kN]	Yielding force in tension of the beam–column joint
$V_{y,c}$	[kN]	Yielding force in compression of the beam–column joint
$d_{y,t}$	[m]	Yielding displacement in tension of the beam–column joint
$d_{y,c}$	[m]	Yielding displacement in compression of the beam–column joint
$V_{max,t}$	[kN]	Maximum force in tension of the beam–column joint
$V_{max,c}$	[kN]	Maximum force in compression of the beam–column joint
$d_{max,t}$	[m]	Maximum displacement in tension of the beam–column joint
$d_{max,c}$	[m]	Maximum displacement in compression of the beam–column joint
$V_{u,t}$	[kN]	Ultimate force in tension of the beam–column joint
$V_{u,c}$	[kN]	Ultimate force in compression of the beam–column joint
$d_{u,t}$	[m]	Ultimate displacement in tension of the beam–column joint
$d_{u,c}$	[m]	Ultimate displacement in compression of the beam–column joint
μ_j	[-]	Displacement ductility factor of the joint

2 ESSENTIAL CHARACTERISTICS AND RELEVANT ASSESSMENT METHODS AND CRITERIA

2.1 Essential characteristics of the product

Table 2.1.1 shows how the performance of the earthquake-resistant kits is assessed in relation to the essential characteristics.

Table 2.1.1 Essential characteristics of the product and methods and criteria for assessing the performance of the product in relation to those essential characteristics

No	Essential characteristic	Assessment method	Type of expression of product performance
Basic Works Requirement 1: Mechanical resistance and stability			
1	Resistance of the truss element in the first phase (beam) ¹	2.2.1	<p>Level and description</p> $F_{b,1} = (M_e; N_p; N_t; N_e; R_w) \quad [kNm; kN; kN; kN; kN]$ <p>or</p> $F_{b,1} = F_f \quad [kN]$
2	Flexural strength of the composite steel-concrete beam in the second phase ¹	2.2.2	<p>Level</p> $M_{b,2} \quad [kNm]$
3	Shear strength of the composite steel-concrete beam in the second phase ¹	2.2.3	<p>Level</p> $V_{b,2} \quad [kN]$
4	Ductility of the beam element in the second phase ¹	2.2.4	<p>Level</p> $\mu_{b,2} \quad [-]$
5	Combined axial force-bending moment resistance of the column element in the first phase ¹	2.2.5	<p>Level and description</p> $(M_{c,1}, N_{c,1}) \quad [kNm, kN]$
6	Combined axial force-bending moment resistance of the column element in the second phase ¹	2.2.6	<p>Level and description</p> $(M_{c,2,A}, N_{c,2,A}) \quad [kNm, kN]$ $(M_{c,2,B}, N_{c,2,B}) \quad [kNm, kN]$ $(M_{c,2,C}, N_{c,2,C}) \quad [kNm, kN]$ $(M_{c,2,D}, N_{c,2,D}) \quad [kNm, kN]$
7	Shear strength of the composite steel concrete column ¹	2.2.7	<p>Level</p> $V_{c,2} \quad [kN]$
8	Ductility of the column element in the second phase ¹	2.2.8	<p>Level</p> $\mu_{c,2} \quad [-]$

No	Essential characteristic	Assessment method	Type of expression of product performance
9	Cyclic behaviour of the earthquake-resistant kit	2.2.9	<p>Level and description</p> <p>$(V_{y,t}; V_{y,c})$ [kN; kN]</p> <p>$(d_{y,t}; d_{y,c})$ [m; m]</p> <p>$(k_{in,t}; k_{in,c})$ [kN/m; kN/m]</p> <p>$(V_{max,t}; V_{max,c})$ [kN; kN]</p> <p>$(d_{max,t}; d_{max,c})$ [m; m]</p> <p>$(V_{u,t}; V_{u,c})$ [kN; kN]</p> <p>$(d_{u,t}; d_{u,c})$ [m; m]</p> <p>$(k_{f,t}; k_{f,c})$ [kN/m; kN/m]</p> <p>β_f [-]</p> <p>μ_j [-]</p>
Basic Works Requirement 2: Safety in case of fire			
10	Fire resistance of the beam ¹	2.2.10	Class
11	Fire resistance of the column ¹	2.2.11	Class
¹ The performance of the component is decisive for the performance of the earthquake-resistant kits with regard to this essential characteristic.			

2.2 Methods and criteria for assessing the performance of the product in relation to essential characteristics of the product

This chapter is intended to provide instructions for TABs. Therefore, such as “shall be stated in the ETA” or “it has to be given in the ETA” shall be understood only as such instructions for TABs on how results of assessments shall be presented in the ETA. Such wordings do not impose any obligations for the manufacturer and the TAB shall not carry out the assessment of the performance in relation to a given essential characteristic when the manufacturer does not wish to declare this performance in the Declaration of Performance.

If for any components covered by harmonised standards or European Technical Assessments the manufacturer of the component has included the performance regarding the relevant essential characteristic in the Declaration of Performance, retesting of that component for issuing the ETA under the current EAD is not required.

2.2.1 Resistance of the truss element in the first phase (beam)

Materials adopted in the first phase

The concrete and the steel rebars used for the kit production shall be defined in the ETA in terms of classes and mechanical properties.

Purpose of the assessment

The purpose of the calculation or of the experimental method is the assessment of the *resistance*, $F_{b,1}$, of the beam type in the first phase (see 1.3.1).

Assessment method

In the first phase of the construction process the beam can be considered as a steel lattice girder simply supported by the columns (see Figure 2.2.1.1). In this phase, the loads the beam is subjected to are:

- Truss element weight (beam self-weight);
- Concrete casting weight;
- Horizontal slab relevant weight;
- Eventual point or line loads;
- Load from work operation and concrete accumulation in accordance with EN 12812.

When subjected to the aforementioned loads, the truss element can show:

- a) Global instability of the element;
- b) Buckling of the top chord;
- c) Buckling of the compressed web diagonals;
- d) Yielding of steel trusses;
- e) Failure of welds.

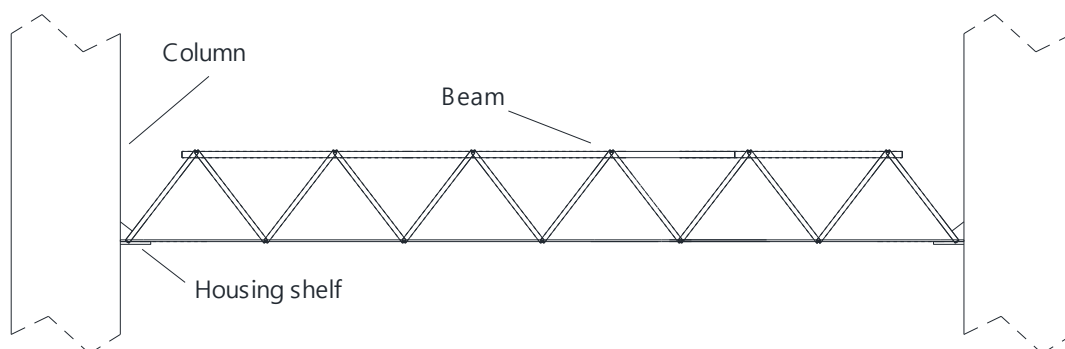

Figure 2.2.1.1: Scheme of the beam element in the first phase

Calculation

The maximum load value leading to the global instability, M_e , shall be assessed according to with the formulation proposed by EN 1993-1-1, clause 8.3.2.1 (Lateral torsional buckling resistance), equation no. 8.78, in combination with the recommendations set forth by Trentadue et al. (2011), as summarized in the following.

According to Trentadue et al. (2011), because of the characteristics of the bars of the top chord, the cross-section of the steel truss structure (Figure 2.2.1.2:) shall be treated as a Class 4 cross-section. As a consequence, the buckling resistance moment of the beam shall be calculated as in equation (2.2.1.1):

$$M_e = M_{b,Rd} = \chi_{LT} \frac{f_y}{\gamma_{M1}} W_{eff,y} \quad (2.2.1.1)$$

Where:

$$\chi_{LT} = \frac{1}{\phi_{LT} + \sqrt{\phi_{LT}^2 - \bar{\lambda}_{LT}^2}} \leq 1,0 \quad (2.2.1.2)$$

$$\phi_{LT} = 0,5[1 + \alpha_{LT}(\bar{\lambda}_{LT} - 0,2) + \bar{\lambda}_{LT}^2] \quad (2.2.1.3)$$

$$\bar{\lambda}_{LT} = \sqrt{\frac{W_{eff,y} f_y}{M_{cr}}} \quad (2.2.1.4)$$

$$\text{And: } W_{eff,y} = \min\{W_u, W_l\}$$

$$W_u = \chi A_u h = \chi \left(\frac{n_u \pi d_u^2}{4} \right) h \quad (2.2.1.5)$$

$$W_l = \chi A_l h = \chi b t h \quad (2.2.1.6)$$

Because the cross-section of a single upper bar can be classified as a Class 1 cross-section, the buckling reduction factor χ shall be calculated as given in equations (2.2.1.7), (2.2.1.8) and (2.2.1.9):

$$\chi = \frac{1}{\phi + \sqrt{\phi^2 - \bar{\lambda}^2}} \leq 1,0 \quad (2.2.1.7)$$

$$\phi = 0,5[1 + \alpha(\bar{\lambda} - 0,2) + \bar{\lambda}^2] \quad (2.2.1.8)$$

$$\bar{\lambda} = \frac{\lambda}{\lambda_1}; \lambda = \frac{s}{d_u/4}; \lambda_1 = \pi \sqrt{\frac{E_s}{f_y}} \quad (2.2.1.9)$$

In the equations above:

- χ_{LT} is the lateral-torsional buckling reduction factor,
- f_y is the yield strength of the steel,
- γ_{M1} is a partial factor equal to 1,00. Assessment with other values of γ_{M1} can additionally be reported in the ETA.
- $W_{eff,y}$ is the effective section modulus,
- A_u is the total area of the upper chord,
- A_l is the area of the bottom chord,
- s is the buckling length of the upper bars (i.e., the spacing between diagonals),
- $d_u/4$ is the radius of gyration of a single bar,

- E_s is the steel elastic modulus,
- α and α_{LT} are imperfection factors both equal to 0,49 and
- M_{cr} is the elastic critical moment for lateral-torsional buckling.

According to Trentadue et al. (2011), the elastic critical moment for lateral-torsional buckling shall be calculated as in equation (2.2.1.10):

$$M_{cr} = C_1 \frac{E_s J_y \pi^2}{l^2} \left[\tilde{h} + \sqrt{\frac{K_{T0}}{E_s J_y} \frac{l^2}{\pi^2} + \tilde{h}^2 + \frac{K_{T1}}{E_s J_y}} \right] \quad (2.2.1.10)$$

The definition of all the parameters that appear in the critical moment equation above, as provided in Trentadue et al. (2011), is reported in the following list:

- \tilde{h} is a parameter which summarizes boundary and loading conditions, and the distance between load and shear centre as in equation (2.2.1.11):

$$\tilde{h} = C_3 \cdot \left(\frac{h_l^2 - h_u^2}{2h} + \frac{\rho_l^2 - \rho_u^2}{2h} \right) - C_2 \cdot (h_l - t_l + h_f) \quad (2.2.1.11)$$

With:

- h_l and h_u are the distances from the shear centre to the mass centre of lower and upper chord, respectively,
- ρ_l and ρ_u are the radius of gyration of the lower and upper chord, respectively,
- t_l is the lower plate (chord) thickness,
- h_f is the load quote measured from the extrados of the lower chord,
- C_1 is equal to 1,046;
- C_2 is equal to 0,430;
- C_3 is equal to 1,120
- l is the free deflection length of the beam,
- J_y is the beam flexural inertia with respect to the weak axis (y axis),
- K_{T0} is the beam primary torsional stiffness obtained from the beam elastic deformation and given in equation (2.2.1.12):

$$K_{T0} = \frac{E_s}{\frac{4}{s} \left(\frac{1}{b_{tr} n_y} \right)^2 \frac{l_{tr}}{A_{tr}} + \alpha_l \frac{2(1+\nu)}{A_l h^2}} \quad (2.2.1.12)$$

with:

- b_{tr} is the diagonal web spacing as in **Fehler! Verweisquelle konnte nicht gefunden werden.**,
- n_y is the cosine director of the diagonal webs,
- l_{tr} is the length of the diagonal webs,
- A_{tr} is the diagonal webs cross-section area,
- α_l is the coefficient for the distribution of shear stresses in the lower chord,
- A_l is the lower chord cross-section area,
- K_{T1} is the beam secondary torsional stiffness as in equation 2.2.1.13:

$$K_{T1} = E_s \cdot \frac{J_{y,u}^* J_{y,l}}{J_{y,u}^* + J_{y,l}} \cdot h^2 \quad (2.2.1.13)$$

with:

- $J_{y,l}$ and $J_{y,u}^*$ are the lower and the upper chord flexural inertia with respect to the weak axis, the latter calculated accounting for the effects of shear deformation,
- h is the distance between the centre of masses of the chords.

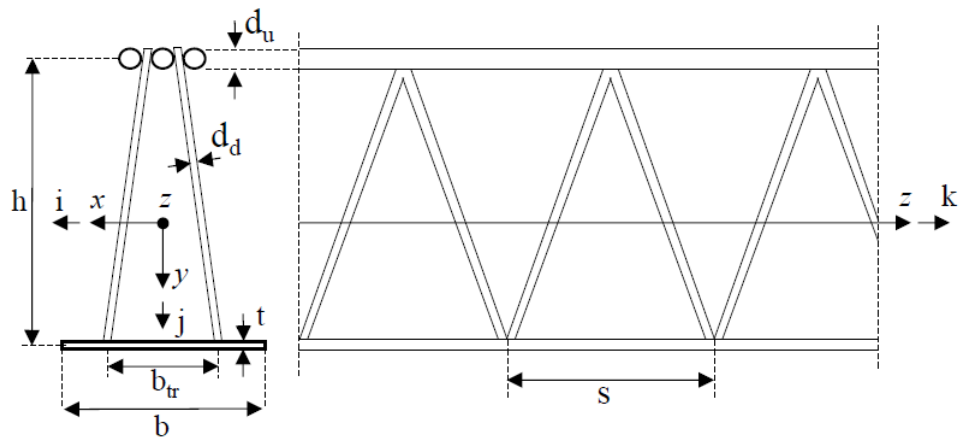

Figure 2.2.1.2: Schematic view of the truss element (left: cross-section; right: side view).

The maximum load value leading to the instability of the top chord, N_p , shall be assessed in accordance with the procedure included in EN 1993-1-1, clause 8.3.1 (Buckling resistance of members – uniform members in compression), so in accordance with equation 2.2.1.14. The buckling length is defined in Figure 2.2.1.3.

$$N_p = N_{b,Rd} = \frac{\chi \cdot A \cdot f_y}{\gamma_{M1}} \quad (2.2.1.14)$$

where:

- χ is the reduction factor for the relevant buckling mode;
- A is the cross-section area of the top plate element;
- f_y is the steel yield strength;
- γ_{M1} is the material partial factor equal to 1,00. Assessment with other values of γ_{M1} can additionally be reported in the ETA.

The reduction factor shall be assessed in accordance with equation 2.2.1.15:

$$\chi = \min \left\{ \frac{1}{\Phi + \sqrt{\Phi^2 - \bar{\lambda}^2}}, 1 \right\} \quad (2.2.1.15)$$

where:

- $\Phi = 0,5[1 + \alpha(\bar{\lambda} - 0,2) + \bar{\lambda}^2]$;
- $\alpha = 0,49$ is the imperfection factor for solid section;
- $\bar{\lambda} = \sqrt{\frac{A \cdot f_y}{N_{cr}}} = \frac{L_{cr}}{i} \cdot \frac{1}{\lambda_1}$
- L_{cr} is the buckling length, assessed as reported in Figure 2.2.1.3;
- $i = \sqrt{\frac{J}{A}}$ is the radius of gyration about the relevant axis, with J cross-section inertia and A cross-section area of the top plate;
- $\lambda_1 = \pi \sqrt{\frac{E}{f_y}} = 93,9 \cdot \varepsilon = 93,9 \cdot \sqrt{\frac{235}{f_y}}$ (f_y in N/mm²).

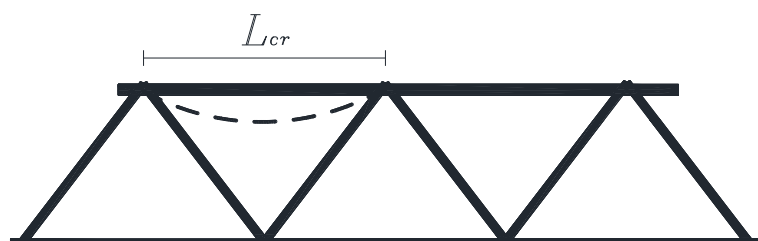

Figure 2.2.1.3: Buckling length of the compressed chord

The maximum load value leading to the instability of the inclined strut, N_t , shall be assessed in accordance with the procedure included in EN 1993-1-1, clause 8.3.1 (Buckling resistance of members – uniform member in compression), as referred to below (equation 2.2.1.16), by substituting the features of the compressed chord with the features of the inclined strut and considering as buckling length, L_{cr} , the length of the inclined element, as shown in Figure 2.2.1.4.

$$N_t = N_{b,Rd} = \frac{\chi \cdot A \cdot f_y}{\gamma_m} \quad (2.2.1.14)$$

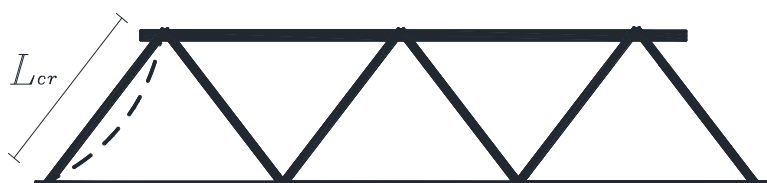

Figure 2.2.1.4: Buckling length of compressed diagonals

The above-mentioned calculation method can be effectively applied if the verification of the weld joint strength is performed in accordance with the procedure included in EN 1090-2.

The ultimate yielding resistance of truss elements, N_e , shall be assessed in accordance with the procedures included in EN 1993-1-1, clause 8.2.3 (Resistance of cross-sections – tension).

$$N_e = N_{pl,Rd} = \frac{A \cdot f_y}{\gamma_{M0}} \quad (2.2.1.15)$$

The welds ultimate resistance, R_w , shall be assessed in accordance with the following equations (included in EN 1993-1-8, clause 6 - Design of joints – welded connections):

$$R_w = F_{w,Rd} = f_{vw,d} \cdot a \quad (2.2.1.18)$$

Where

- $f_{vw,d} = \frac{f_u / \sqrt{3}}{\beta_w \gamma_{M2}}$
- f_u is the nominal ultimate tensile strength of the weaker part joined;
- β_w is the appropriate correlation factor taken from Table 6.1 of EN 1993-1-8;
- γ_{M2} is the partial safety factor equal to 1,25. Assessment with values of γ_{M2} set by Member States can additionally be reported in the ETA;
- a is the the design effective throat thickness of flare groove weld, defined as in Figure 2.2.1.6.

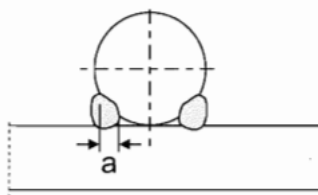

Figure 2.2.1.6: Effective throat thickness of flare groove welds in solid sections

Experimental test

The ultimate load of the truss element (beam type, see 1.3.1) in the first phase can be also assessed in accordance with the experimental procedure given in Annex A.

The experimental method indicated in Annex A shall be used as reference method to determine the ultimate load of the truss element (beam type, see 1.3.1) in the first phase.

Expression of results

If the assessment is carried out by calculation, the ultimate load of the beam type in the first phase shall be given in the ETA by a vector composed of the values corresponding to the instability of the whole element, the instability of the top chord, the instability of the compressed diagonals, the yielding of tensile cross-sections and the failure of welds:

- a. The maximum bending moment leading to the instability of the whole element: M_e
- b. The maximum axial force leading to the instability of the top chord: N_p
- c. The maximum axial force leading to the instability of the diagonals: N_t
- d. The maximum axial force leading to the yielding of the tensile cross-sections: N_e
- e. The welds maximum strength: R_w

$$F_{b,1} = (M_e; N_p; N_t; N_e; R_w)$$

If the experimental method is used to assess this essential characteristic, these values shall be assessed in accordance with the procedure included in Annex A and stated in the ETA as:

$$F_{b,1} = F_f$$

Information about the used method, i.e., calculation or experimental test, shall be given in the ETA.

The results are valid for the specific beam type (see 1.3.1) and concrete type.

2.2.2 Flexural strength of the composite steel-concrete beam in the second phase

Purpose of the assessment

The purpose of the calculation or of the experimental method herein presented is the assessment of the flexural strength, $M_{b,2}$, of the beam type (see 1.3.1) when is completed with the concrete casting (second phase).

Assessment method

Calculation

In the second phase the beam can be considered as a reinforced concrete element, and the flexural strength can be assessed from well-developed principle of mechanics. Considering the cross-section in Figure 2.2.2.1., the flexural strength of the beams shall be calculated by simultaneously satisfying compatibility, equilibrium and material stress-strain relationships, with the following assumptions:

- plane sections remain plane;
- the strain in bonded reinforcement, whether in tension or in compression, is the same as that in the surrounding concrete;

- the tensile strength of the concrete is ignored;
- the stresses in the concrete in compression are dealt with using appropriate equivalent stress blocks;
- the stresses in the reinforcing steel are derived from appropriate elasto-plastic stress strain relationships.

The cross-section ultimate strain profile is achieved once ultimate concrete strain at extreme compressed fibre reaches the ultimate value ε_{cu} (e.g., 0,0035). The tensile strain in the steel reinforcement (ε_s) shall be greater than 0,005, in order to ensure a ductile behaviour of the cross-sections. The stress block coefficients which shall be used to assess the compressive stress and force in the concrete are given in equation (2.2.2.1) and equation (2.2.2.2):

$$\alpha = \begin{cases} 0,85 & \text{for } f_{ck} \leq 50 \text{ MPa} \\ 0,85 - 0,85 \left[\frac{(f_{cd}-50)}{200} \right] & \text{for } 50 \text{ MPa} \leq f_{ck} \leq 90 \text{ MPa} \end{cases} \quad (2.2.2.16)$$

$$\beta = \begin{cases} 0,80 & \text{for } f_{ck} \leq 50 \text{ MPa} \\ 0,80 - \left[\frac{(f_{cd}-50)}{400} \right] & \text{for } 50 \text{ MPa} \leq f_{ck} \leq 90 \text{ MPa} \end{cases} \quad (2.2.2.2)$$

The area of longitudinal tension reinforcement shall not be taken as less than $A_{s,min}$:

$$A_{s,min} = 0,26 \frac{f_{ctm}}{f_{yk}} b_t d \geq 0,0013 b_t d \quad (2.2.2.3)$$

Where:

- b_t denotes the mean width of the tension zone;
- f_{ctm} shall be determined with respect to the relevant strength class.

The cross-sectional area of tension or compression reinforcement shall not exceed $A_{s,max}$ outside lap splice locations:

$$A_{s,max} = 0,04 A_c \quad (2.2.2.4)$$

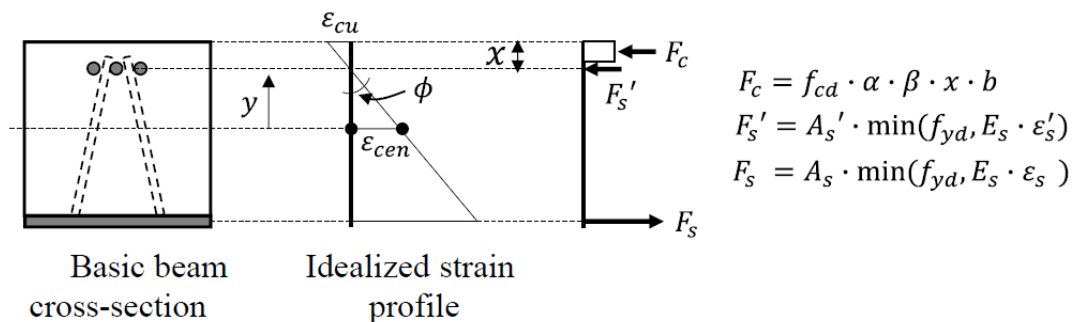

Figure 2.2.2.1: Beam cross-section ultimate strain and stress profiles

Experimental test

The flexural strength of the beam type in the second phase can be also assessed in accordance with the experimental procedure shown in 0.

The value of flexural strength shall be assessed from the maximum recorded force, F_u , in accordance with 0. In particular:

$$M_{b,2} = M_u \quad (2.2.2.5)$$

The experimental method indicated in Annex B shall be used as reference method to determine the flexural strength of the beam type in the second phase.

Expression of results

The *flexural strength* of the beam type in the second phase shall be stated in the ETA as the level of $M_{b,2}$ assessed according to calculation or experimental method as given above, together with the information whether calculation or experimental method has been used

The concrete used for the beam casting shall also be given in the ETA in terms of class and mechanical properties.

The results are valid for the specific beam type (see 1.3.1) and concrete type.

2.2.3 Shear strength of the composite steel-concrete beam in the second phase

Purpose of the assessment

The purpose of the calculation or of the experimental method herein presented is the assessment of the shear strength, $V_{b,2}$, of the beam type in the second phase (see 1.3.1).

Assessment method

Calculation

The calculation of the shear strength of the beam type is based on a truss model made of concrete struts and inclined steel ties (i.e., the diagonal elements of the reinforcing truss), as shown in Figure 2.2.2.3.1:

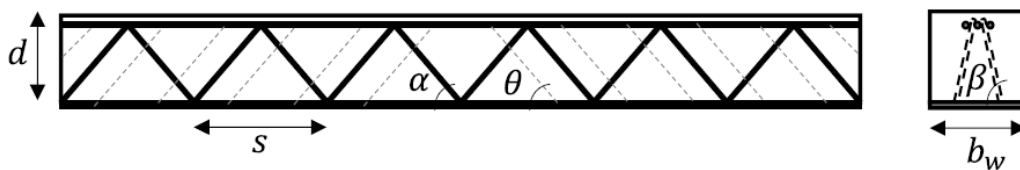

Figure 2.2.2.3.1: Beam truss model for shear strength calculation

The shear strength of the beams shall be calculated in accordance with the following equations:

$$V_{b,2} = V_{Rd} = \min(V_{Rd,s}, V_{Rd,c}) \quad (2.2.3.17)$$

$$V_{Rd,s} = \frac{0,9dA_{sd}f_{yd}}{s} (\cot\alpha + \cot\theta) \sin\alpha \sin\beta \quad (2.2.3.18)$$

$$V_{Rd,c} = zb_w v_1 f_{cd} (\cot\alpha + \cot\theta) / (1 + \cot^2\theta) \quad (2.2.3.3)$$

Where:

- α is the angle of the shear reinforcement with the longitudinal axis;
- β is the angle of the shear reinforcement in the plane of the cross-section;
- θ is the angle of the concrete struts with the longitudinal axis; in the critical regions of beams in DCH (ductility class high) systems, the strut inclination ϑ in the truss model shall be taken as 45° ;
- z denotes, for a member with constant depth, the internal lever arm corresponding to the maximum bending moment in the element under consideration. In the shear analysis, the approximate value $z=0,9d$ shall be used;
- v_1 is the reductive coefficient of the cracked concrete for shear that shall be taken as 0,5;
- A_{sd} is the cross-sectional area of the diagonal elements of the truss that act as shear reinforcement; the maximum effective shear area $A_{sd,max}$ for $\cot\theta=1$ is given by $\frac{A_{sd,max}f_{ywd}}{b_ws} \leq \frac{0,25f_{cd}}{\sin\alpha \sin\beta}$.

The ratio of shear reinforcement shall be calculated as:

$$\rho_d = A_{sd}(s \cdot b_w \cdot \sin\alpha) \quad (2.2.3.4)$$

$$\rho_{d,\min} = \frac{0,08\sqrt{f_{ck}}}{f_{yk}} \quad (2.2.3.5)$$

Experimental test

The shear strength of the beam type in the second phase can be also assessed experimentally in accordance with the procedure explained in 0. In particular:

$$V_{b,2} = V_u \quad (2.2.3.6)$$

The experimental method indicated in Annex B shall be used as reference method to determine the shear strength of the composite beam in the second phase.

Expression of results

The *shear strength* of the beam type in the second phase shall be stated in the ETA as the level of $V_{b,2}$, obtained from the calculation method or the experimental test herein illustrated, together with the information whether calculation or experimental method has been used.

In case of experimental test the value of *shear strength* shall be assessed from the ultimate force leading to the shear failure, in accordance with 0.

The concrete used for the beam casting shall also be given in the ETA in terms of class and mechanical properties.

The results are valid for the specific beam type (see 1.3.1) and concrete type.

2.2.4 Ductility of the beam element in the second phase

Purpose of the assessment

The purpose of the calculation or of the experimental method herein presented is the assessment of the ductility, $\mu_{b,2}$, of a beam type in the second phase (see 1.3.1).

Assessment method

Calculation

The curvature ductility factor of the cross-section shall be calculated as reported in equation (2.2.4.1) (see Figure 2.2.2.1):

$$\mu_{b,2} = \frac{\chi_u}{\chi_e} \quad (2.2.4.1)$$

where:

$$\chi_u = \frac{\varepsilon_{cu}}{x_u} \quad (2.2.4.2)$$

$$\chi_e = \frac{\varepsilon_{sy}}{(d-x_e)} \quad (2.2.4.3)$$

With:

- ε_{cu} is the ultimate concrete strain equal to 0,0035;
- x_u is the depth of beam cross-section neutral axis at ultimate conditions;
- ε_{sy} is the tensile strain in the steel reinforcement at yielding conditions;
- d is the effective depth of the beam cross-section;
- x_e is the depth of beam cross-section neutral axis at yielding conditions.

Experimental tests

The ductility of the beam type in the second phase can be also experimentally assessed in accordance with the procedure explained in 0.

The experimental method indicated in Annex B shall be used as reference method to determine the ductility of the composite beam in the second phase.

Expression of results

The ductility of the beam type, $\mu_{b,2}$, in the second phase shall be represented in the ETA by the level of the curvature ductility factor assessed according to the calculation method herein presented, or by the level of the displacement ductility factor included in Annex B.

The concrete used for the beam casting shall also be defined in the ETA in terms of class and mechanical properties, together with the information whether calculation or experimental method has been used.

The results are valid for the specific beam type (see 1.3.1) and concrete type.

2.2.5 Combined axial force-bending moment resistance of the column element in the first phase

Purpose of the assessment

The purpose of the calculation herein described is the assessment of the combined axial force – bending moment resistance, of the column type in the first phase (see 1.3.1) of the construction process. The assessment of such resistance can be conducted by means of calculation method.

Assessment method

Calculation

The assessment of the combined axial force-bending moment resistance of the column type in the first phase shall be conducted in accordance with equations no. 8.88 and no. 8.89 included in EN 1993-1-1, clause 8.3.3 (buckling resistance of members – uniform members in bending and axial compression). In particular:

$$M_{c,1} = M_{Rd} = \chi_{LT} \frac{M_{Rk}}{\gamma_{M1}} \quad (2.2.5.1)$$

$$N_{c,1} = N_{Rd} = \chi_Z \frac{N_{Rk}}{\gamma_{M1}} \quad (2.2.5.2)$$

where χ_{LT} , χ_Z , M_{Rk} , N_{Rk} are defined in clause 8.3.3 of EN 1993-1-1. For the material partial factor, $\gamma_{M1} = 1,00$ shall be used. Assessment with values of γ_{M1} set by Member States can additionally be reported in the ETA.

Expression of results

The combined axial force – bending moment resistance of the column type in the first phase shall be represented in ETA by the couple $(M_{c,1}, N_{c,1})$.

The results are valid for the specific column type (see 1.3.1) and concrete type.

2.2.6 Combined axial force-bending moment resistance of the column element in the second phase

Purpose of the assessment

The purpose of the calculation or the experimental method herein described is the assessment of the combined axial force – bending moment resistance of column type(see 1.3.1), in the second phase of the construction process.

Assessment method**Calculation**

The combined axial force – bending moment resistance of the column type in the second phase can be assessed in accordance with procedure included in EN 1994-1-1 in clause 6.7.3.2 (5), as long as the provisions reported in Section 6.7.3.1 of EN 1994-1-1 are fulfilled.

Experimental test

The combined axial force-bending moment resistance of the column type in the second phase can be also experimentally assessed in accordance with the procedure explained in 0.

The experimental method indicated in Annex C shall be used as reference method to determine the combined axial force-bending moment resistance of the column in the second phase.

Expression of results

The combined axial force – bending moment resistance of the column type in the second phase shall be represented in ETA by a M-N limit domain defined by a minimum of 4 points, as reported in 0.

- Point A: $(M_{c,2,A}, N_{c,2,A})$;
- Point B: $(M_{c,2,B}, N_{c,2,B})$;
- Point C: $(M_{c,2,C}, N_{c,2,C})$;
- Point D: $(M_{c,2,D}, N_{c,2,D})$;

Information about the used method, i.e., calculation or experimental test, shall be given in the ETA.

The results are valid for the specific column type (see 1.3.1) and concrete type.

2.2.7 Shear strength of columnsPurpose of the assessment

The purpose of the calculation or the experimental method herein reported is the assessment of the shear strength, $V_{c,2}$, of column type in the second phase (see 1.3.1) of the construction process.

Assessment method**Calculation**

The shear strength of the column type in the second phase shall be taken as the plastic shear resistance of the structural steel section $V_{pl,a,Rd}$ (equation 2.2.7.1), unless the value for a contribution from the reinforced concrete part of the column has been established:

$$V_{c,2} = V_{pl,a,Rd} = \frac{A_v(f_y/\sqrt{3})}{\gamma_{M0}} \quad (2.2.7.1)$$

Where:

- $A_v = Ah/(b+h)$ for rectangular hollow sections;
- $A_v = 2A/\pi$ for circular hollow sections;
- A is the cross-sectional area;
- b is the overall breadth;
- h is the overall depth;
- $\gamma_{M0} = 1,0$.

The shear contribution of the reinforced concrete part shall be carried out using the Eurocode approach reported in the equation (2.2.7.2):

$$V_{Rd,Rc} = \min \left(\frac{A_{sw}}{s} z f_{ywd} \cot \theta; \frac{\alpha_{cw} b_w z v_1 f_{cd}}{\cot \theta + \tan \theta} \right) \quad (2.2.7.2)$$

Where:

- θ is the angle of the concrete struts with the longitudinal axis, equal to 45°;
- b_w is the minimum width of the web;
- z denotes, for a member with constant depth, the internal lever arm corresponding to the maximum bending moment in the element under consideration. In the shear analysis, the approximate value $z=0,9d$ shall be used;
- A_{sw} is the cross-sectional area of the shear reinforcement; the maximum effective shear area $A_{sw,max}$ for $\cot \theta=1$ is given by $\frac{A_{sw,max} f_{ywd}}{b_w s} \leq \frac{1}{2} \alpha_{cw} v_1 f_{cd}$;
- s is the spacing of the stirrups;
- f_{ywd} is the design yield strength of the shear reinforcement;
- v_1 is the reductive coefficient of the cracked concrete for shear that can be taken as 0,5;
- α_{cw} is a coefficient taking account the state of the stress in the compression chord (equal to 1,0 for column).

Experimental test

The shear strength of the column type in the second phase can be also experimentally assessed in accordance with the procedure explained in 0.

The experimental method indicated in Annex C shall be used as reference method to determine the shear strength of the column in the second phase.

Expression of results

The *shear strength* of the column type in the second phase, $V_{c,2}$, shall be represented in the ETA by the level of the plastic shear resistance if calculation method is used, or the level of the ultimate force leading to the shear failure, in accordance with 0. In particular, $V_{c,2}$ corresponds to (equation 2.2.7.3):

$$V_{c,2} = V_u \quad (2.2.7.3)$$

Information about the used method, i.e., calculation or experimental test, shall be given in the ETA.

The results are valid for the specific column type (see 1.3.1) and concrete type.

2.2.8 Ductility of column elements

Purpose of the assessment

The purpose of the experimental method herein presented is the assessment of the ductility, $\mu_{c,2}$, of the column type in the second phase (see 1.3.1).

Assessment method

The overall displacement ductility of a column in the second phase shall be experimentally assessed in accordance with the procedure explained in 0.

Expression of results

The ductility of a column type in the second phase shall be represented in the ETA by the level of the displacement ductility factor in accordance with the procedure included in 0.

The results are valid for the specific beam type (see 1.3.1) and concrete type.

2.2.9 Cyclic behaviour of the earthquake-resistant kit

Purpose of the assessment

The purpose of the experimental method herein presented is the assessment of the earthquake-resistant kit subjected to cyclic actions.

Assessment method

Experimental test

The beam-column joint resistance shall be experimentally assessed in accordance with the experimental procedure explained in 0.

The experimental method indicated in Annex D shall be used as reference method to determine the cyclic behaviour of the earthquake-resistant kit.

Calculation

The cyclic behaviour of the earthquake-resistant kit assessment can also be performed by means of a numerical method.

The numerical assessment shall then be done for different beam-column joint configurations in terms of:

- geometrical features of the specimen (i.e., cross-section dimensions of the beam and column, diameter of internal steel reinforcement bars, spacing of the steel reinforcement bars, thickness of hollow steel elements for columns);
- mechanical properties of the adopted materials for the kit components (i.e., type of steel adopted for steel reinforcement bars, type of concrete).

Numerical assessment shall be performed by means of a numerical model (based on FEM or analytical approach) validated on the basis of the experimental assessment method.

The numerical model shall be able to reproduce:

- the geometrical properties of the test specimen in terms of cross-section dimensions of the beam and column, total length of the beam and the column, reinforcement bars length and spacing;
- the mechanical properties of concrete and steel bars. Advanced non-linear finite element models (FEM) shall be used. The used FE (finite element) programme shall be able to model key behaviour aspects of concrete and composite structures like crack sliding, bond slip, and tension stiffening;
- the position of the loading points in accordance with 0;
- the loading protocol in accordance with 0.

The calibration and reliability of the numerical models shall be performed by comparing the numerical results with experimental data. Performance metrics shall focus on key aspects, including: (i) strength, (ii) stiffness, and (iii) ductility.

To achieve this, the following parameters shall be extracted or calculated from the experimental results:

- peak strength: the maximum (both positive and negative) force resisted by the specimen;
- initial stiffness: the stiffness measured between $\pm 10\%$ of the first cycle on the 0,5% drift hysteretic force-displacement curve;
- yield displacement: determined using a secant line through 75% of the peak strength on the specimen's backbone force-displacement curve;
- ultimate displacement: defined as the post-peak displacement at 85% of the peak strength on the backbone force-displacement curve;
- ductility: calculated as the ratio of ultimate displacement to yield displacement.

The same parameters shall be extracted or calculated from the results of the numerical analysis.

The numerical model shall be considered adequately calibrated and validated if all key parameters (i.e., peak strength, initial stiffness, and ductility) from the numerical analysis fall within $\pm 5\%$ of the corresponding experimental values.

Details about numerical model and validation procedure shall be provided in ETA. Confidential information is deposited at the Technical Assessment Body, where relevant.

Expression of results

The cyclic behaviour of the earthquake-resistant kit shall be stated in the ETA in terms of experimental resulting curves and level of the relevant parameters, as explained in 0:

- Yielding forces, $V_{y,t}$, $V_{y,c}$
- Yielding displacements corresponding to yielding force, $d_{y,t}$, $d_{y,c}$
- Initial stiffness, $k_{in,t}$ and $k_{in,c}$
- Maximum forces, $V_{max,t}$, $V_{max,c}$
- Maximum displacements $d_{max,t}$, $d_{max,c}$
- Ultimate forces, $V_{u,t}$, $V_{u,c}$
- Ultimate displacements, $d_{u,t}$, $d_{u,c}$,
- Final stiffness, $k_{f,t}$ and $k_{f,c}$
- Final relative energy dissipation ratio, β_f
- Displacement ductility factor, μ_j

2.2.10 Fire resistance of the beam

Purpose of the assessment

The purpose of the calculation and of the experimental methods herein presented is the assessment of the fire resistance of the beam type in second phase (see 1.3.1).

Assessment method

Calculation

The fire resistance of the beam shall be assessed in accordance with clause 6.6 of EN 1992-1-2.

Experimental test

The fire resistance of beam shall be assessed in accordance with the experimental procedure included in EN 1364-3, in order to be classified in accordance with EN 13501-2.

Expression of results

The fire resistance of the beam elements shall be represented in the ETA by the class obtained by calculation method or experimental tests herein described. The results are valid for the specific beam type (see 1.3.1) and concrete type.

2.2.11 Fire resistance of the column

Purpose of the assessment

The purpose of the calculation and of the experimental methods herein presented is the assessment of the fire resistance of the column type in second phase (see 1.3.1).

Assessment method

Calculation

The fire resistance of the column shall be assessed in accordance with EN 1992-1-2, clause 6.3, by using the Method B.

Experimental test

The fire resistance of column shall be assessed in accordance with the experimental procedure included in EN 1364-4, in order to be classified in accordance with EN 13501-2.

Expression of results

The fire resistance of the column elements shall be represented in the ETA by the class obtained by calculation method or experimental tests herein described. The results are valid for the specific column type (see 1.3.1) and concrete type.

3 ASSESSMENT AND VERIFICATION OF CONSTANCY OF PERFORMANCE

3.1 System(s) of assessment and verification of constancy of performance to be applied

For the products covered by this EAD the applicable European legal act is Commission Decision 98/214/EC, as amended by Commission Decision 2001/596/EC.

The system is 2+.

3.2 Tasks of the manufacturer

The cornerstones of the actions to be undertaken by the manufacturer of the product in the procedure of assessment and verification of constancy of performance are laid down in Table 3.2.1.

For kits: The manufacturer (regarding the components he buys from the market with DoP) shall take into account the Declaration of Performance issued by the manufacturer of that component. No retesting is necessary.

Table 3.2.1 Control plan for the manufacturer; cornerstones

No	Subject/type of control	Test or control method	Criteria, if any	Minimum number of samples	Minimum frequency of control
Factory production control (FPC) [including testing of samples taken at the factory in accordance with a prescribed test plan]					
1	Incoming material	Supplier data check	According to control plan	-	100% Batch
2	Incoming steel profiles/Dimensions	Measurement – calliper/gauge	According to control plan	1	Each delivery
3	Steel bar, steel plates, steel hoops and welded wire mesh/ Dimensions after cutting and bending operation	Measurement – calliper /gauge	According to control plan	Control plan	Control plan
4	Steel bar/ Resistance after bending operation	Control plan	According to control plan	3	Daily
5	Final elements/ Dimensions	Measurement – calliper /gauge	According to control plan	1	100% Batch
6	Steel elements/ Welding control	Visual inspection	According to control plan	All	Continuously
7	Steel elements/ Welding control	Non-destructive tests (NDT)	According to control plan	All	In accordance with clause 12.4.2.3 of EN 1090-2

3.3 Tasks of the notified body

The cornerstones of the actions to be undertaken by the notified body in the procedure of assessment and verification of constancy of performance for the earthquake-resistant kit are laid down in Table 3.3.1.

Table 3.3.1 Control plan for the notified body; cornerstones

No	Subject/type of control	Test or control method	Criteria, if any	Minimum number of samples	Minimum frequency of control
Initial inspection of the manufacturing plant and of factory production control					
1	Notified Body will ascertain that the factory production control with the staff and equipment are suitable to ensure a continuous and orderly manufacturing of the "earthquake-resistant kit".	Verification of the complete FPC as described in the control plan agreed between the TAB and the manufacturer	According to Control plan	According to Control plan	When starting the production or a new line
Continuous surveillance, assessment and evaluation of factory production control					
2	The Notified Body will ascertain that the system of factory production control and the specified manufacturing process are maintained taking account of the control plan.	Verification of the controls carried out by the manufacturer as described in the control plan agreed between the TAB and the manufacturer with reference to the raw materials, to the process and to the product as indicated in Table 3.2.1	According to Control plan	According to Control plan	Once per year

4 REFERENCE DOCUMENTS

EN 1090-2:2018+A1:2024	Execution of steel structures and aluminium structures - Part 2: Technical requirements for steel structures
EN 1364-3: 2014	Fire resistance tests for non-loadbearing elements - Part 3: Curtain walling - Full configuration (complete assembly)
EN 1364-4:2014	Fire resistance tests for non-loadbearing elements - Part 4: Curtain walling - Part configuration
EN 1992-1-1:2023	Eurocode 2: Design of concrete structures - Part 1-1: General rules and rules for buildings, bridges and civil engineering structures
EN 1992-1-2:2023	Eurocode 2: Design of concrete structures - Part 1-2: Structural fire design
EN 1993-1-1:2022	Eurocode 3: Design of steel structures - Part 1-1: General rules and rules for buildings
EN 1993-1-8:2024	Eurocode 3: Design of steel structures - Part 1-8: Joints
EN 1994-1-1:2004+AC:2009	Eurocode 4: Design of composite steel and concrete structures - Part 1-1: General rules and rules for buildings
EN 1994-1-2:2005+A1:2014	Eurocode 4: Design of composite steel and concrete structures - Part 1-2: Structural fire design
EN 1998-1:2004+A1:2013	Eurocode 8: Design of structures for earthquake resistance – Part 1: General rules, seismic actions and rules for buildings
EN 12812: 2008	Falsework - Performance requirements and general design
EN 13501-2:2023	Fire classification of construction products and buildings elements – Part 2: Classification using data from fire resistance tests, excluding ventilation services
EN ISO 4063:2023	Welding, brazing, soldering and cutting - Nomenclature of processes and reference numbers (ISO 4063:2023)
Trentadue et al. (2011)	Trentadue, F., Quaranta, G., Marano, G.C., Monti, G. "Simplified Lateral-Torsional Buckling Analysis in Special Truss-Reinforced Composite Steel-Concrete Beams," J. Struct. Eng., 2011, 137(12): 1419-1427.

ANNEX A ULTIMATE LOAD OF STEEL LATTICE GIRDER BEAM IN THE FIRST PHASE

A.1 Test specimens

The specimens to be tested shall be representative of the selected "beam type" (see clause 1.3.1) in the first phase, in terms of dimensions and material. Different lengths of the selected "beam type" shall be tested in order to investigate different instability failure modes. The minimum length, useful for the assessment of the ultimate load leading to the instability of the first inclined tie, corresponds to the length of the beam modulus (unit) as shown in Figure A.1.1: The maximum length corresponds to the total length of the beam, L_b . (Figure A.1.2:).

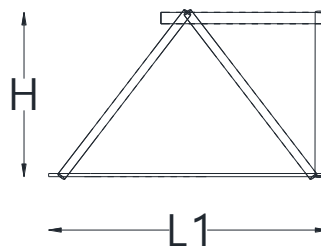

Figure A.1.1: Geometrical features of the specimen for the assessment of the load leading to the instability of the inclined diagonal (H =beam height, L_1 =length of the beam modulus)

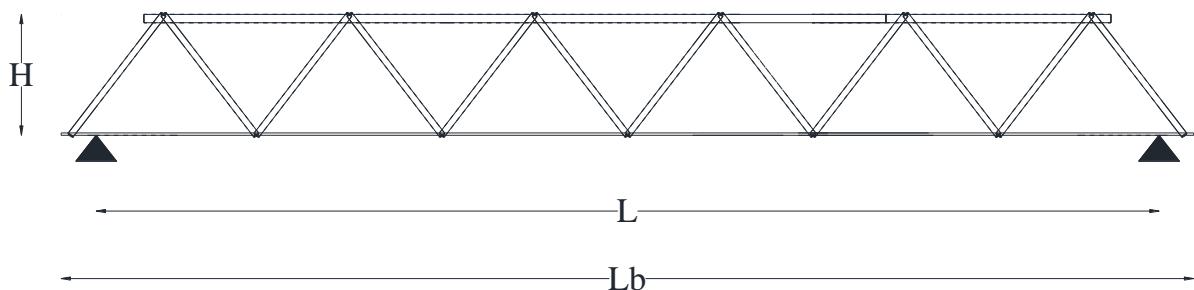

Figure A.1.2: Features of the beam for the assessment of the load-bearing capacities of the whole element (H =beam height, L_b =length of the beam, L =distance between supports)

A.2 Number of tests

One test shall be performed for each beam configuration.

A.3 Test setup and equipment

The assessment of the ultimate load leading to the instability of the inclined diagonal shall be conducted using the test setup shown in Figure A.3.1. and Figure A.3.2. Two portions of each specimen shall be considered in order to symmetrically apply the loads; the two parts shall be connected to each other through bolts. A hydraulic jack shall be used to apply the load in vertical direction.

The assessment of the ultimate load leading to the instability of the top steel element or whole element shall be carried out using the test setup shown in Figure A.3.3: In order to guarantee a simply supported beam scheme, two steel rollers with a dimension of 40 ± 10 mm shall be used as supporting device and with a steel plate with a dimension of 80 ± 20 mm between each supporting rollers and the specimen.

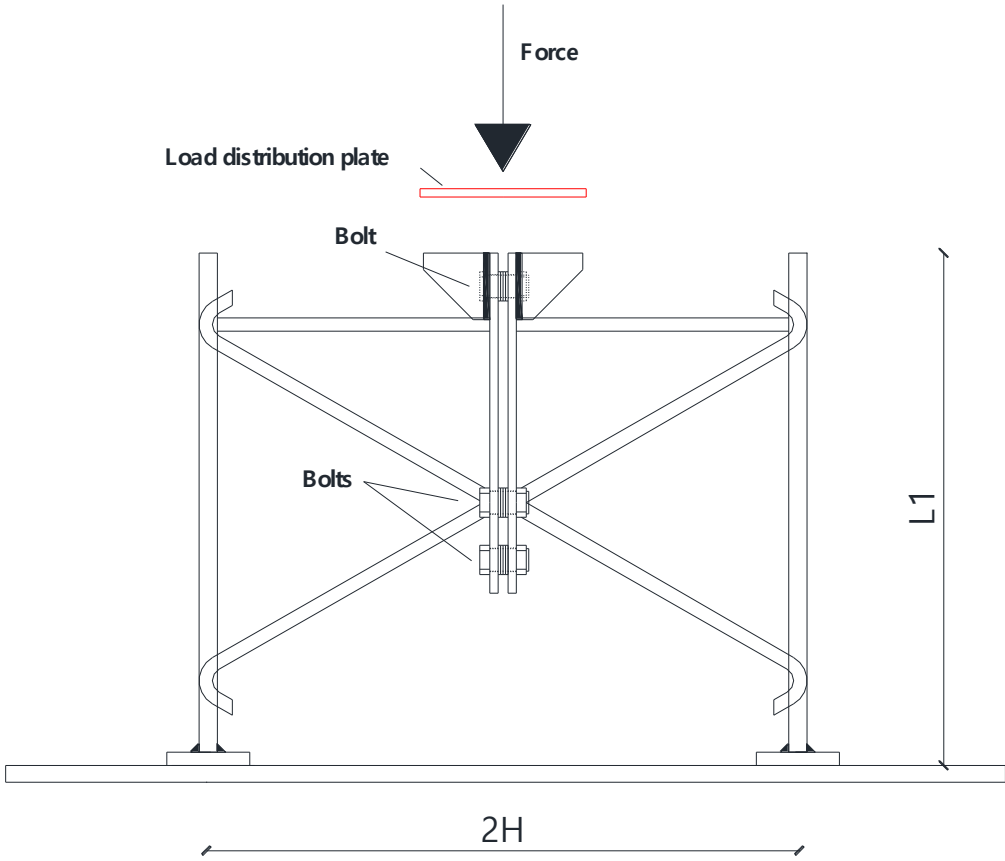

Figure A.3.1: Test setup for the assessment of the diagonal instability load in the first phase (frontal view)

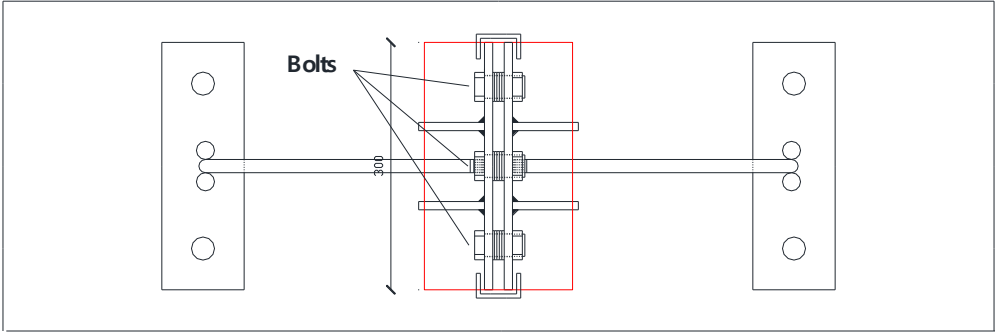

Figure A.3.2: Test setup for the assessment of the diagonal instability load in the first phase (plane view)

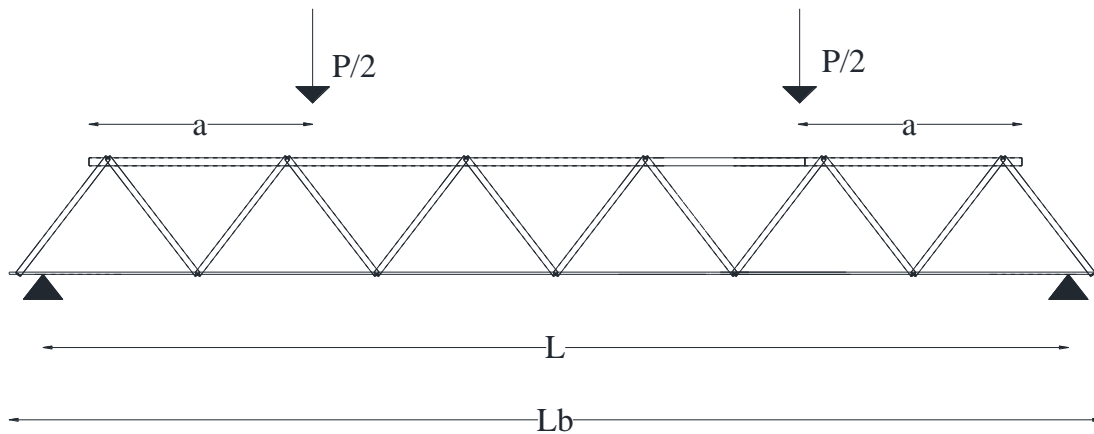

Figure A.3.3: Test setup for the assessment of the ultimate load capacity in the first phase (L_b =length of the beam, L =distance between supports, a =distance of load application point from the supports)

A.4 Test procedure

The tests shall be conducted by applying the load in the position as specified in Figure A.3.1 for the assessment of the diagonal instability load.

For the assessment of the ultimate load capacity two equal loads shall be applied, each at the distance, d equal to one quarter of the span from the supports, identified as L in Figure A.3.3.

In both cases, the load shall be increased monotonically to specimen failure, at a loading rate of 30 (± 1) kN/min.

A.5 Test report

As a minimum requirement, the report shall include the following information:

General

- Description of the specimen in terms of dimension and used material
- Description of the test setup (geometry)
- Description of the testing equipment: load cells, displacement transducers, software, hardware, data recording system
- Number of executed tests

Measured values

- Parameters of load application (e.g., rate of increase of load or size of load increase steps);
- Failure mode: the report shall specify which failure mode, between global instability of the element; buckling of the top chord, yielding of steel trusses, occurred.
- Failure load (F_f) and corresponding solicitations.

ANNEX B ASSESSMENT OF THE FLEXURAL AND THE SHEAR STRENGTH OF THE BEAM IN THE SECOND PHASE

B.1 Test specimens

The testing shall be carried out on specimens that fully represent the selected “beam type” element (see clause 1.3.1) in the second phase, i.e., when it is completed with concrete cast in situ, in terms of dimensions and material. The specimens shall be assembled in strict accordance with the manufacturer’s product installation instructions.

B.2 Number of tests

One test shall be performed for each beam configuration.

B.3 Test setup and equipment

Figure 0.1 shows the test setup for the assessment of flexural and the shear strength of the composite steel-concrete beam. A symmetrical four-points loading scheme shall be considered as shown in Figure 0.1.

Given the height, H , of the selected “beam type”, the loading position, “ a ”, shall be chosen according to the following indications:

- for the assessment of the flexural strength $a/H=7$;
- for the assessment of the shear strength $3 < a/H < 7$

The beam shall be simply supported.

Load distribution plates shall be arranged between the specimen and the actuator in order to avoid local effects. Displacement transducers shall be arranged on the specimen in order to assess the beam deflection in the middle span.

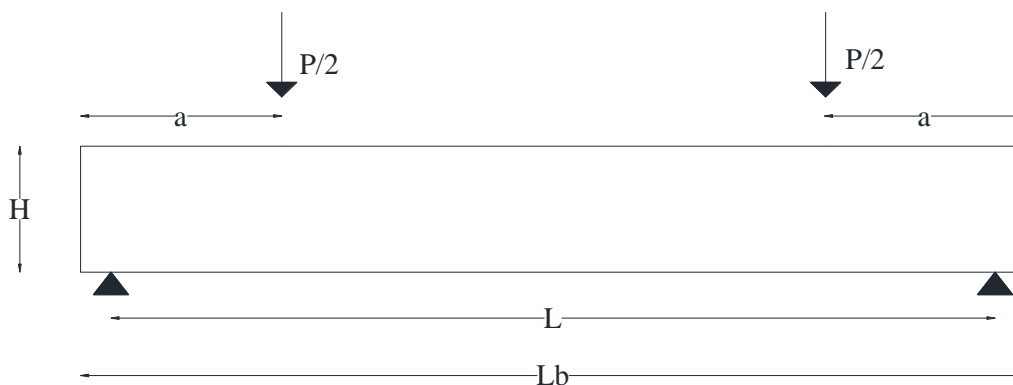

Figure 0.1: Setup for beam flexural tests

B.4 Test procedure

The tests shall be conducted by applying the load in the specified positions. The load shall be increased monotonically to beam failure, at a loading rate of 30 (± 1) kN/min. Beam deflection in the middle span shall be recorded continuously up to the end of the test.

B.5 Test report

As a minimum requirement, the report shall include at least the following information:

General

- Description of the specimen in terms of dimension and used material

- Description of the test setup (geometry)
- Description of the testing equipment: load cells, displacement transducers, software, hardware, data recording system
- Number of executed tests

Measured values

- Parameters of load application (e.g., rate of increase of load or size of load increase steps);
- Applied force-middle span displacement curve provided as in the example of **Fehler! Verweisquelle konnte nicht gefunden werden.**, with relevant parameters:
 - F_y is the force corresponding to steel bar yielding;
 - d_y is the beam deflection corresponding to F_y ;
 - F_{max} is the maximum load reached during the test;
 - d_{max} is the beam deflection corresponding to F_{max} ;
 - F_u is the load corresponding to a 20% reduction of the F_{max} ;
 - d_u is the beam deflection corresponding to F_u ;
- Description of failure mode;
- In bending tests, the ultimate bending moment assessed according to equation B.5.1:

$$M_u = F_u \cdot a \quad (0.1)$$

- In shear tests, the ultimate shear strength assessed in accordance with equation B.5.2:

$$V_u = F_u \quad (0.2)$$

- In bending tests, the displacement ductility factor shall be assessed as the ratio between the ultimate displacement and the yielding displacement read in the force-displacement curve:

$$\mu_{b,2} = \frac{d_u}{d_y} \quad (0.3)$$

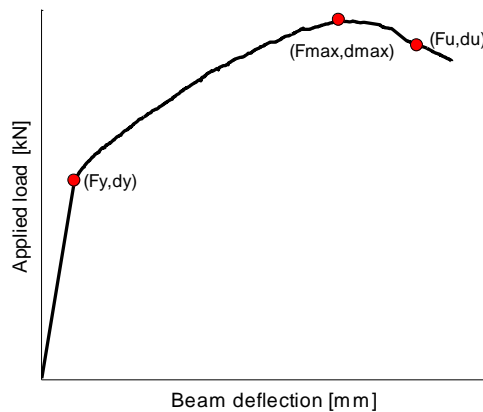

Figure 0.1: Example of experimental force-displacement curve

ANNEX C ASSESSMENT OF THE COMBINED AXIAL FORCE-BENDING MOMENT RESISTANCE AND SHEAR STRENGTH OF THE COLUMN ELEMENT

C.1 Test specimens

The specimen shall be representative of a the selected “column type” element (see clause 1.3.1) both in the first and the second phase of the construction process, in terms of dimensions and materials. The specimen shall be assembled in strict accordance with the manufacturer’s product installation instructions.

C.2 Number of tests

C.2.1 Axial force – bending moment domain

Five tests shall be conducted for each column configuration in order to identify some specific points of the M-N limit domain (Figure 0.1.1):

1. Test 1 (point A of the limit domain): keep lateral force constant and equal to zero and increase the axial force continuously and constantly with a loading rate up to $30 (\pm 1)$ kN/min up to column failure;
2. Test 2 (point B of the limit domain): keep the axial force constant and equal to zero and increase the lateral force continuously and constantly with a loading rate up to $30 (\pm 1)$ kN/min up to column failure;
3. Test 3 (point C of the limit domain): keep the axial force constant and equal to $0,85 \cdot f_{cd} \cdot A_c$ (for concrete encased and partially concrete encased sections) and increase the lateral force continuously and constantly with a loading rate up to $30 (\pm 1)$ kN/min up to column failure;
4. Test 4 (point D of the limit domain): keep the axial force constant and equal to $1/2$ of $0,85 \cdot f_{cd} \cdot A_c$ (for concrete encased and partially concrete encased sections) and increase the lateral force continuously and constantly with a loading rate up to $30 (\pm 1)$ kN/min up to column failure.

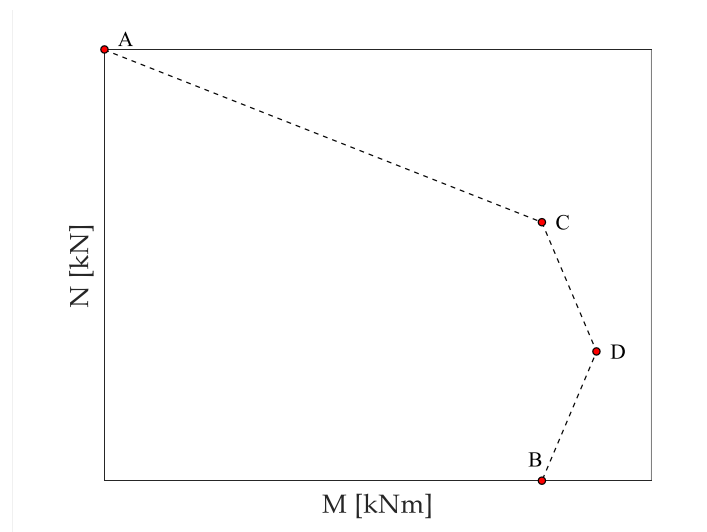

Figure 0.1.1: Example of M-N limit curve for a column

For not-symmetric column elements the M-N limit curve shall be assessed in the two main directions of the cross-section.

C.2.2 Shear strength of the column

One test shall be performed for each column configuration.

C.3 Test setup and equipment

The assessment of the combined axial force-bending moment resistance of the column element shall be carried out using the test setup shown in Figure 0.1.

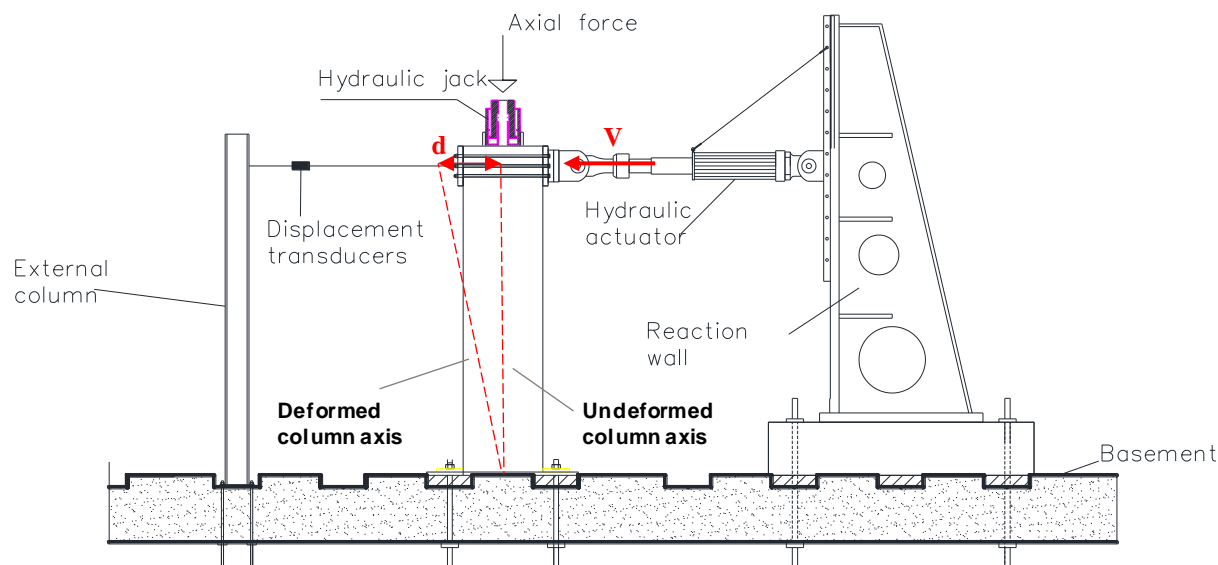

Figure 0.1: Test setup for the assessment of static and cyclic behaviour of the column element

C.4 Test procedure

C.4.1 Axial force – bending moment domain

In order to assess the combined axial force - bending moment domain of a column element in the first or the second phase, the axial force shall be applied by an actuator in the vertical direction together with a lateral force applied by a horizontal actuator. Displacement transducers shall be applied at the top of the column as reported in Figure C.3.1 in order to continuously record the top displacement, d .

C.4.2 Shear strength of the column

The assessment of the column shear strength shall be conducted by applying a constant axial force in vertical direction while the lateral force increases monotonically with a loading rate of $30 (\pm 1)$ kN/min. The column dimensions shall be chosen in such a way that shear failure is induced. An aspect ratio L_v/H equal to 1,5 shall be considered as a first approximation, where L_v is the shear span (height from the base to the loading point) and H is the section depth (dimension of the cross-section in the loading direction). Displacement transducers shall be applied at the top of the column as reported in Figure C.3.1 in order to continuously record the top displacement, d .

C.5 Test report

As a minimum requirement, the report shall include the following information:

General

- Description of the specimen in terms of dimension and used material
- Description of the test setup (geometry)
- Description of the testing equipment: load cells, displacement transducers, software, hardware, data recording system
- Number of executed tests

Measured values

- Parameters of load application (e.g., rate of increase of load or size of load increase steps);
- If axial force – bending moment behaviour is investigated - M-N limit domain provided as in the example of Figure 0.1.1;
- If shear strength is investigated – applied lateral force (V) - drift (Δ) (i.e., recorded displacement, d , divided by the column height) curve provided as in the example of Figure 0.1, shall be obtained from

recorded values of applied load (V) and displacement, d (see Figure C.3.1) with the following relevant parameters:

- V_y is the yielding force corresponding to steel bars yielding
 - Δ_y is the column drift corresponding to V_y
 - V_{max} is the maximum load reached during the test
 - Δ_{max} is the column drift corresponding to V_{max}
 - V_u is the load corresponding to a 20% reduction of the V_{max}
 - Δ_u is the column drift corresponding to V_u
- Failure mode;
- the displacement ductility factor is assessed as reported in equation (C.5.1).

$$\mu_{c,2} = \frac{d_u}{d_y} \quad (0.1)$$

Where:

- d_u , is the displacement corresponding to V_u
- d_y , is the displacement corresponding to V_y

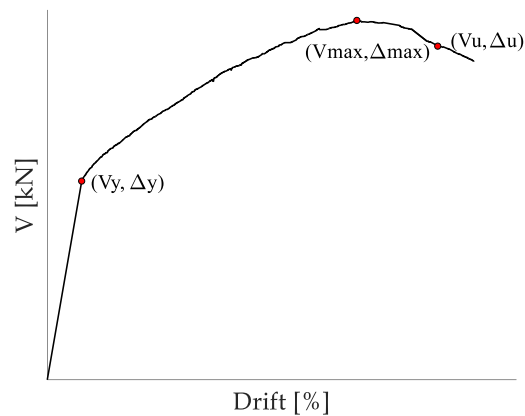

Figure 0.1: Example of lateral force-drift monotonic curve of the column

ANNEX D TEST METHOD FOR THE ASSESSMENT OF THE CYCLIC BEHAVIOUR OF THE EARTHQUAKE-RESISTANT KIT

D.1 Test specimens

The specimen shall be representative of a real beam to column joint. The cross-section dimensions of the beam and column shall be chosen in accordance with the design of the structure in which the elements are intended to be used. The total length of the column shall be representative of the structure inter-story height (H), the beam length at each side of the joint shall be $1/3$ (the zero point of the bending moment diagram) of the total beam length (L). The specimen geometry is detailed in Figure 0.1.

The specimen shall be assembled in strict accordance with the manufacturer's product installation instructions.

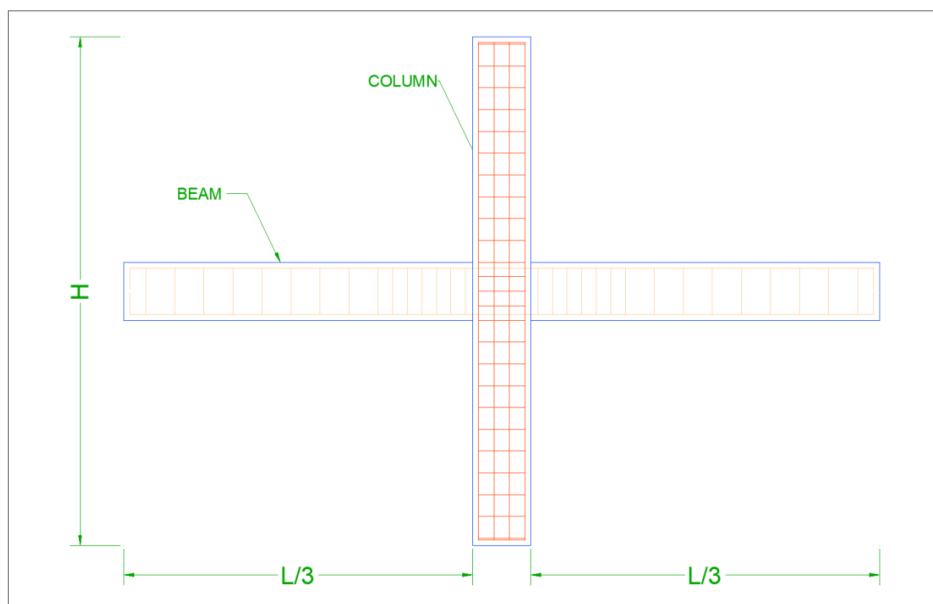

Figure 0.1: Dimension of the beam - column joint

D.2 Test setup and equipment

The experimental setup is schematically shown in Figure 0.1. The specimen shall be connected to a strong floor through two steel rods pinned to the extremity of each beam (Figure 0.1c) and through a cylindrical hinge located at the base of the column (Figure 0.1d). The top of the column shall be rigidly connected to two servo-controlled hydraulic actuators intended to simultaneously apply the desired loads (Figure 0.1b).

Quasi-static reversed cyclic horizontal loads along with a constant axial load shall to be applied at the top of the column through two servo-controlled actuators (Figure 0.2).

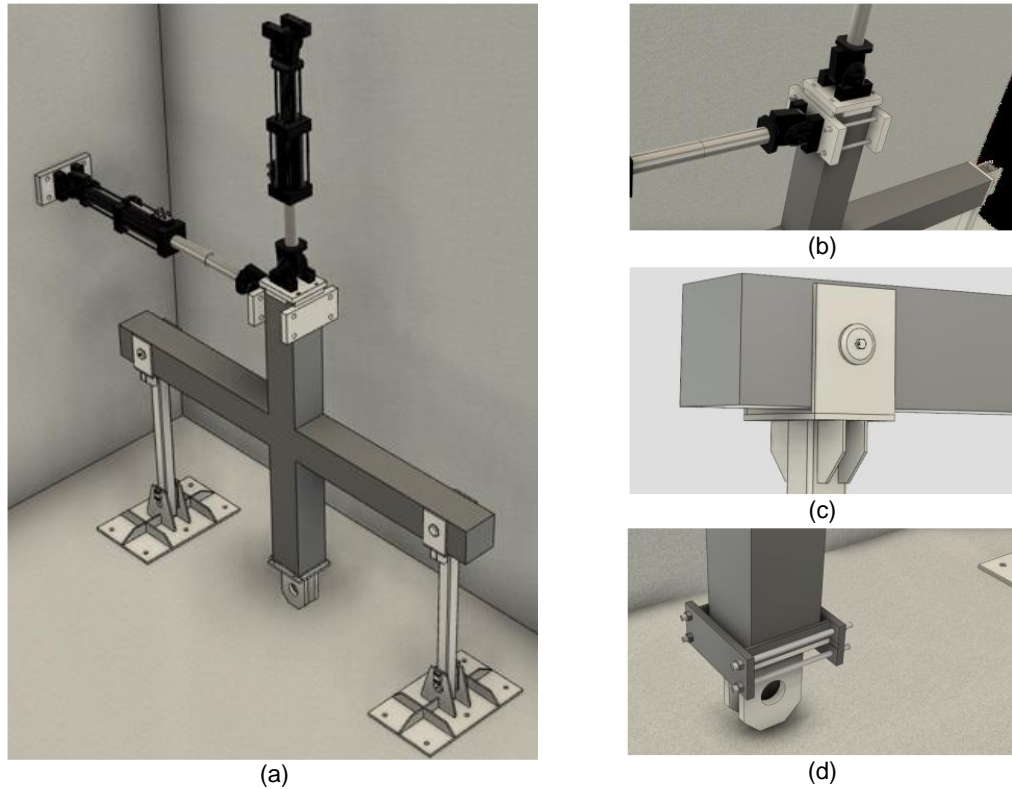

Figure 0.1: Example of test setup for cyclic tests: (a) experimental setup overview, (b) actuator-column connection detail, (c) beam support connection detail, (d) base of column detail

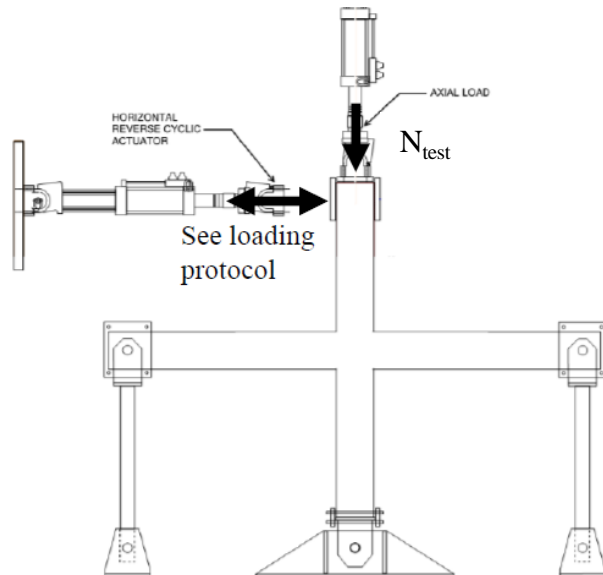

Figure 0.2: View of loading configuration

The joint response shall be measured in real time using a combination of Linear Variable Displacement Transducers (LVDTs) and strain gauges, mounted on the front and back surfaces of the beam-column joints around the panel region (using concrete anchors) or arranged to monitor the horizontal displacements of the systems.

A possible Linear Variable Displacement Transducer (LVDT) distribution is reported in Figure 0.3: More specifically:

- 3 LVDT shall be mounted at the strong floor level to monitor potential displacements of the base supports;
- 4 LVDT shall be used to measure potential out-of-plane displacements;
- 6 LVDT shall be mounted at various heights along the height of the column (including one set up to directly monitor the horizontal displacement of the beam along the beam centreline);
- 12 LVDT (6 on the front and 6 on the back) shall be dedicated to monitor the average displacements of the panel zone;
- 24 LVDT shall be arranged to provide data pertaining to the panel zone rotation, and the beam and column rotation near the interface region (Figure 0.4).

The strain gauge shall be attached directly to selected reinforcing bars and shall be located to allow monitoring of a wide range of reinforcing elements.

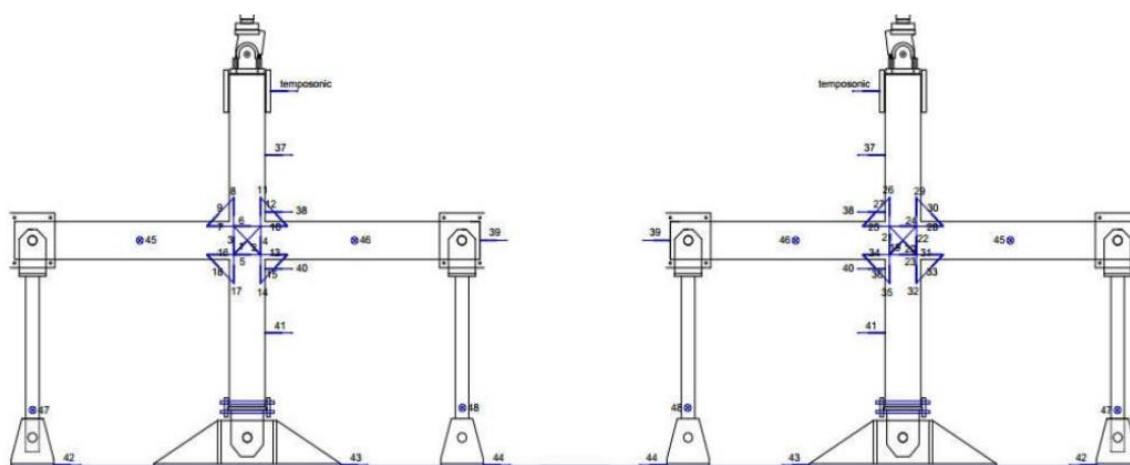

Figure 0.3: Surface Instrumentation/LVDT Arrangement, Front (left) – back (right)

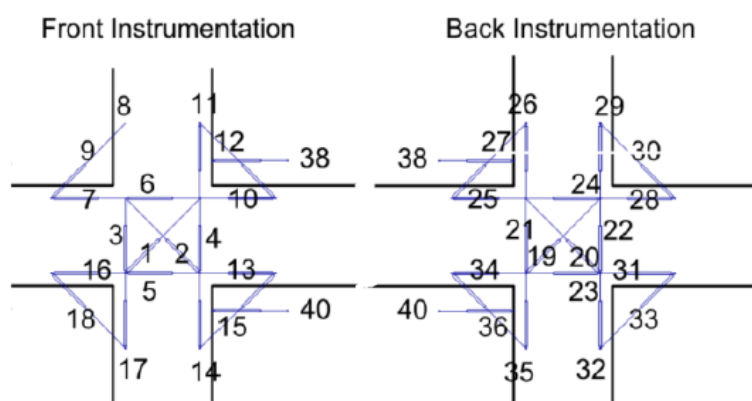

Figure 0.4: LVDT arrangement within joint region

D.3 Test procedure

The test shall be carried out in displacement control, following the loading protocol summarized in Table 0.1, consisting in the application of three cycles at each selected load stage, except for stages 1 and 2 for which one cycle shall be carried out. For each cycle the displacement amplitude shall be increased up to the indicated drift ratio (assessed as the ratio between the applied displacement and the column height), in both positive and negative loading direction.

The axial load (N_{test}) to be applied shall be assessed assuming that:

$$v = \frac{N_{test}}{N_{R,cd}} = \frac{N_{test}}{A_c f_{cd}} = 0,05$$

Where:

- A_c is the cross-sectional area of the reference reinforced concrete column;
- f_{cd} is concrete compressive strength of the reference specimen.

Table 0.1. Loading protocol

Load stage #	Drift ratio [%]	Axial load [kN]	Velocity [mm/s]	Number of cycles
1	-	0,05 $N_{R,cd}$	1 kN/s	1
2	0,10		0,05	1
3	0,25		0,10	3
4	0,50		0,20	3
5	1,00		0,40	3
6	1,50		0,60	3
7	2,00		0,80	3
8	3,00		1,20	3
9	4,00		1,60	3
10	5,00		2,00	3

The joint response in term of lateral force shall be measured in real time by means of a load cell located at the level of the displacement actuator.

D.4 Test report

As a minimum requirement, the report shall include at least the following information:

General

- Description of the specimens in terms of dimension and used material
- Description of the test setup (geometry)
- Description of the testing equipment: load cells, linear variable displacement transducer (LVDTs), strain gauges, software, hardware, data recording system
- Number of executed tests

Measured values

- Recorded Force (V) - applied displacement (d) (or force-drift) curve, provided as in the example of Figure 0.1;
- Backbone curve, obtained as envelope of the previous curve from which the following relevant parameters are to be valuated, both in tension (t) and compression (c):
 - Yielding force, i.e., the maximum value of elastic force, $V_{y,t}$, $V_{y,c}$;
 - Yielding displacement corresponding to yielding force, $d_{y,t}$, $d_{y,c}$;
 - Initial stiffness, $k_{in,t}$ and $k_{in,c}$, assessed as the ratio between the yielding force and the yielding displacement:

$$k_{in,c} = \frac{V_{y,c}}{d_{y,c}} \quad (0.1)$$

$$k_{in,t} = \frac{V_{y,t}}{d_{y,t}} \quad (0.2)$$

- Maximum forces $V_{max,t}$, $V_{max,c}$;
- Maximum displacements corresponding to maximum forces $d_{max,t}$, $d_{max,c}$;
- Ultimate forces corresponding to peak force of the cycle at drift ratio equal to 3%, both in tension and compression $V_{u,t}$, $V_{u,c}$;
- Ultimate displacements, corresponding to drift ratio of 3%, $d_{u,t}$, $d_{u,c}$;
- Final stiffness, $k_{f,t}$ and $k_{f,c}$ assessed as the stiffness at drift ratio equal to 0,003 (and -0,003) of the third cycle of the load stage 8 (corresponding to maximum drift ratio equal to 3%). See Figure 0.2.
- Final relative energy dissipation ratio, β_f , assessed at the loading stage 8 (corresponding to maximum drift ratio equal to 3%), in accordance with equation D.4.3:

$$\beta_f = A_h / (E_1 + E_2) \cdot (\theta'_1 + \theta'_2) \quad (0.3)$$

Where, as shown in Figure 0.3:

- k and k' correspond to $k_{in,t}$ and $k_{in,c}$;
- E_1 and E_2 are the peak lateral resistances for the third cycle for the positive and negative loading directions;
- A_h is the area of the hysteresis loop for the third cycle; The circumscribing figure consists of two parallelograms, ABCD and DFGA. The slopes of the lines AB and DC are the same as the initial stiffness K for positive loading, and the slopes of the lines DF and GA are the same as the initial stiffness K' for negative loading. The areas of the parallelograms equal the sum of the absolute values of the lateral force strengths, E_1 and E_2 , at the drift ratios θ_1 and θ_2 multiplied by the sum of the absolute values for the drifts ratios θ'_1 and θ'_2 .
- Displacement ductility factor assessed as the ratio between the ultimate displacement and the yielding displacement read in the force-displacement curve (see figure D.4.1) . The value shall be assessed both in tension and in compression; the minimum of the two values shall be considered as the ductility factor.

$$\mu_j = \min (\mu_{j,c}, \mu_{j,t}) \quad (0.4)$$

where:

$$\mu_{j,c} = \frac{d_{u,c}}{d_{y,c}} \quad (0.5)$$

$$\mu_{j,t} = \frac{d_{u,t}}{d_{y,t}} \quad (0.6)$$

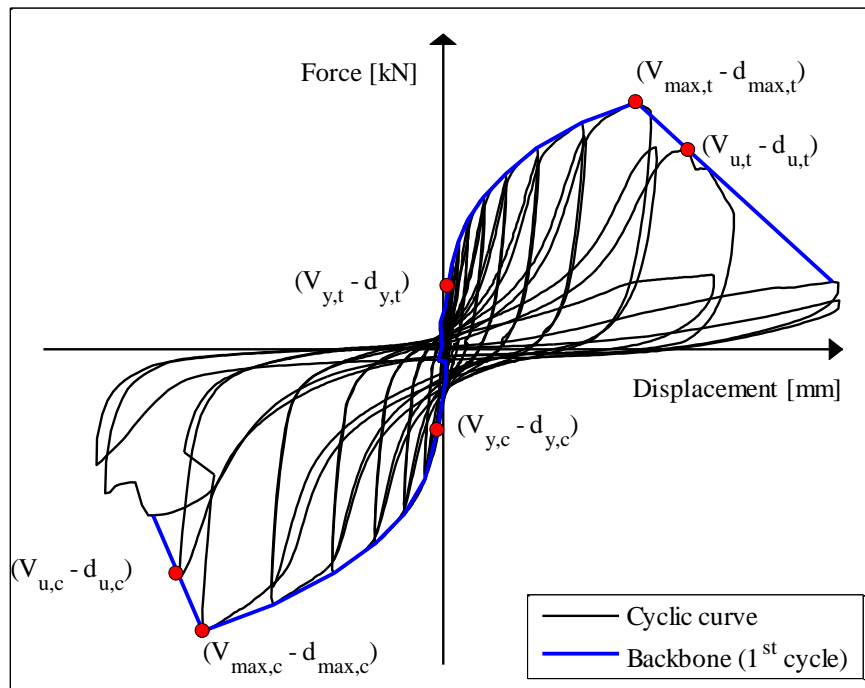

Figure 0.1: Example of force-displacement cyclic curve of the beam - column joint and relative backbone curve with relevant parameters

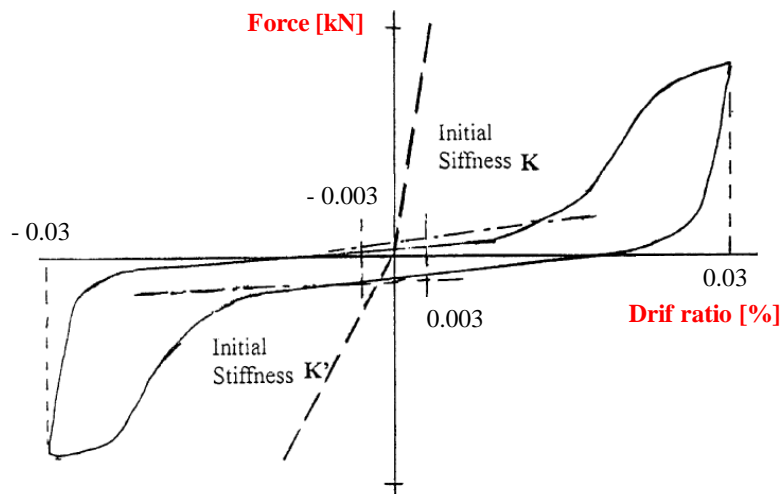

Figure 0.2: Example for assessment of final stiffness

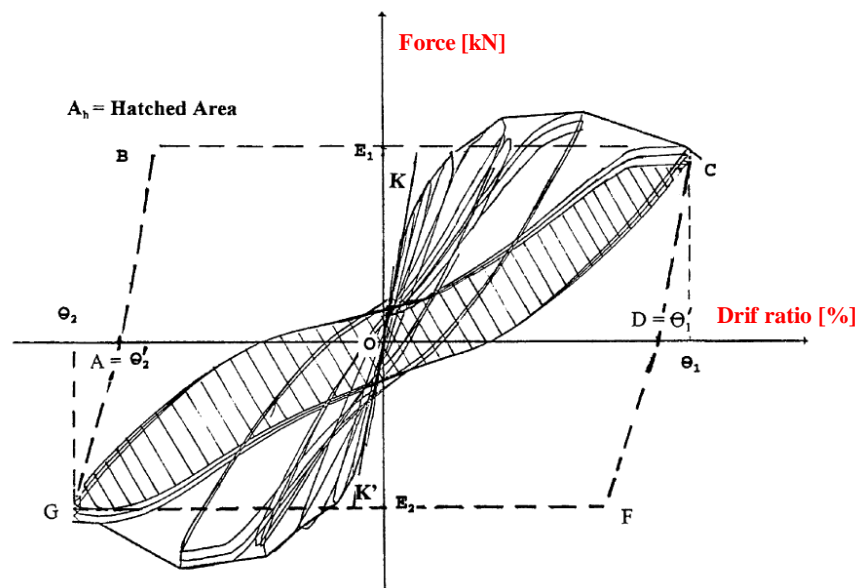

Figure 0.3: Example for assessment of final relative energy dissipation ratio

- Crack pattern (Figure 0.4) and failure mode (Figure 0.5)

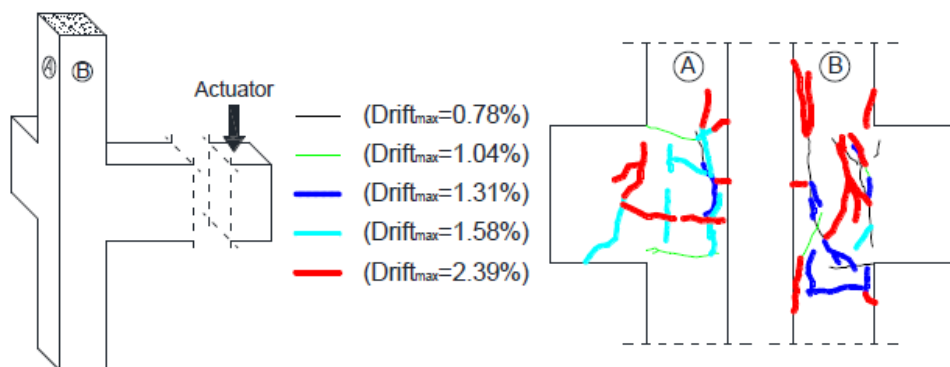

Figure 0.4: Example of crack pattern during cyclic tests for an external joint

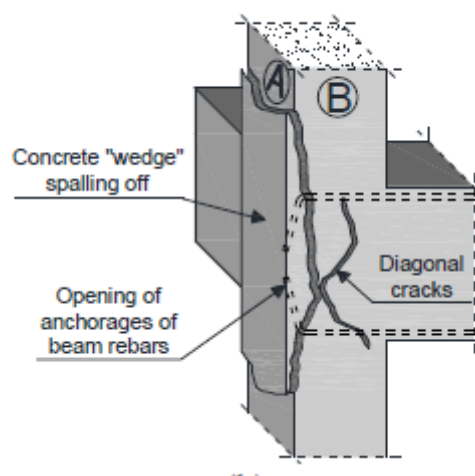

Figure 0.5: Example of schematic representation of failure mode of an external joint