

EUROPEAN ASSESSMENT DOCUMENT

EAD 220010-01-0402

May 2019

**FLAT PLASTIC ROOFING SHEETS
MADE OF RECYCLED PLASTIC
FOR SELF-SUPPORTING AND/OR
FULLY SUPPORTED
DISCONTINUOUS ROOFING AND/
OR EXTERNAL CLADDING**

The reference title and language for this EAD is English. The applicable rules of copyright refer to the document elaborated in and published by EOTA.

This European Assessment Document (EAD) has been developed taking into account up-to-date technical and scientific knowledge at the time of issue and is published in accordance with the relevant provisions of Regulation (EU) No 305/2011 as a basis for the preparation and issuing of European Technical Assessments (ETA).

Contents

1	Scope of the EAD	4
1.1	Description of the construction product	4
1.2	Information on the intended use(s) of the construction product	4
1.2.1	Intended use(s).....	4
1.2.2	Working life/Durability	5
2	Essential characteristics and relevant assessment methods and criteria.....	6
2.1	Essential characteristics of the product	6
2.2	Methods and criteria for assessing the performance of the product in relation to essential characteristics of the product	7
2.2.1	Reaction to fire	7
2.2.2	External fire performance of roofs	7
2.2.3	Content, emission and/or release of dangerous substances	8
2.2.4	Hard body impact resistance.....	8
2.2.5	Tensile strength and elongation	9
2.2.6	Dimensions and tolerances.....	9
2.2.7	Weight.....	9
2.2.8	Flexural strength.....	9
2.2.9	Pull-through resistance	10
2.2.10	Tear resistance.....	10
2.2.11	UV stability	10
2.2.12	Resistance to heat	11
2.2.13	Resistance to low temperature.....	12
2.2.14	Resistance to water penetration.....	12
2.2.15	Vicat softening temperature (VST)	12
2.2.16	Resistance to point load.....	13
3	Assessment and verification of constancy of performance	14
3.1	System(s) of assessment and verification of constancy of performance to be applied	14
3.2	Tasks of the manufacturer	14
3.3	Tasks of the notified body	16
4	Reference documents	17
ANNEX A	Resistance to pull-through and tear resistance	19
ANNEX B	Hard body impact resistance	21
ANNEX C	Guidance for test of reaction to fire on plastic sheets for fully supported discontinuous roofing and external cladding.....	22
ANNEX D	Resistance to point loads.....	26

1 SCOPE OF THE EAD

1.1 Description of the construction product

The EAD applies to the flat plastic roofing sheets for self-supporting and/ or fully supported discontinuous roofing and/or external cladding made of the recycled plastic (flat plastic roofing sheet - FPRS). Product is specified for the minimal roof slope at least 18° up to 90°.

The product is small-format flat plastic roofing, alternatively including wind rivet.

The composition of recycled plastic material and its origin are given in the ETA.

There are more types of FPRS. The following information are given in the ETA:

- nominal dimensions and thickness of the FPRS including its tolerances
- nominal weight of FPRS
- nominal dimensions and shape of wind rivet including its tolerances and mechanical characteristics
- types and performances of nails in use according to EN 10230-1¹.

Manufacturer can supply FPRS in two ways:

- FPRS without wind rivet
- FPRS with wind rivet, packed separately.

The product is not covered by a harmonised European standard (hEN).

The products according to this EAD are not fully covered by EAD 220069-00-0402 because EAD 220069-00-0402 does not cover product made of other material than copolymer PE/PP and are only for fully supported discontinuous roofing.

The products according to this EAD are not fully covered by EAD 220010-00-0402 because EAD 220010-00-0402 does not cover product made of other material than PVC in the range of 4 – 9 mm.

In comparison to the EAD 220010-00-0402, in this EAD the following clauses and annexes have been changed or added: Title of EAD, Cl. 1, Cl. 2.1, 2.2.1, 2.2.2, 2.2.3, 2.2.4, 2.2.5, 2.2.6, 2.2.7, 2.2.8, 2.2.9, 2.2.10, 2.2.11, 2.2.12, 2.2.13, 2.2.14, 2.2.15, 2.2.16, 2.2.17, 3.1, 3.2, 3.3, 4, Annex A, Annex B, Annex C.

Concerning product packaging, transport, storage, maintenance, replacement and repair it is the responsibility of the manufacturer to undertake the appropriate measures and to advise his clients on the transport, storage, maintenance, replacement and repair of the product as he considers necessary.

It is assumed that the product will be installed according to the manufacturer's instructions or (in absence of such instructions) according to the usual practice of the building professionals. Relevant manufacturer's stipulations having influence on the performance of the product covered by this European Assessment Document shall be considered for the determination of the performance and detailed in the ETA.

1.2 Information on the intended use(s) of the construction product

1.2.1 Intended use(s)

Product is used for discontinuous covering the sloping and high-pitched roofs and cladding on external walls. FPRS is nailed in the place of prepared holes or in the place recommended by the manufacturer to

¹ All undated references to standards or to EADs in this EAD are to be understood as references to the dated versions listed in clause 4.

planking, laths or grid support. They are fixed against uplifting by a bending down the wind rivet at the bottom of sheet. The product is intended for use(s) in conjunction with underlay according to EN 13859.

The FPRS is not a load-bearing component. They are to be fixed to a full-surface base construction on roofs (planking) or to a laths or grids on walls.

1.2.2 Working life/Durability

The assessment methods included or referred to in this EAD have been written based on the manufacturer's request to take into account a working life of the discontinuous plastic roofing for the intended use of 25 years when installed in the works (provided that the discontinuous plastic roofing is subject to appropriate installation (see 1.1)). These provisions are based upon the current state of the art and the available knowledge and experience.

When assessing the product, the intended use as foreseen by the manufacturer shall be taken into account. The real working life may be, in normal use conditions, considerably longer without major degradation affecting the basic requirements for works².

The indications given as to the working life of the construction product cannot be interpreted as a guarantee neither given by the product manufacturer or his representative nor by EOTA when drafting this EAD nor by the Technical Assessment Body issuing an ETA based on this EAD, but are regarded only as a means for expressing the expected economically reasonable working life of the product.

² The real working life of a product incorporated in a specific works depends on the environmental conditions to which that works is subject, as well as on the particular conditions of the design, execution, use and maintenance of that works. Therefore, it cannot be excluded that in certain cases the real working life of the product may also be shorter than referred to above.

2 ESSENTIAL CHARACTERISTICS AND RELEVANT ASSESSMENT METHODS AND CRITERIA

2.1 Essential characteristics of the product

Table 1 shows how the performance of FPRS is assessed in relation to the essential characteristics.

Table 1 Essential characteristics of the product and methods and criteria for assessing the performance of the product in relation to those essential characteristics

No	Essential characteristic	Assessment method	Type of expression of product performance
Basic Works Requirement 2: Safety in case of fire			
1	Reaction to fire	Cl. 2.2.1	Class
2	External fire performance of roofs	Cl. 2.2.2	Class
Basic Works Requirement 3: Hygiene, health and the environment			
3	Content, emission and/or release of dangerous substances	Cl. 2.2.3	Level Content of Cd [mg/kg]
Basic Works Requirement 4: Safety and accessibility in use			
4	Hard body impact resistance	Cl. 2.2.4	Level $E [N*m]$
5	Tensile strength and elongation	Cl. 2.2.5	Level $\sigma_{t,c} [N/mm^2]$ $\epsilon [\%]$
6	Dimensions - length, width, thickness - deviation of flatness	Cl. 2.2.6	Level $l [mm], b [mm], d [mm]$ $S_{max} [mm]$
7	Weight	Cl. 2.2.7	Level $m [kg]$
8	Flexural strength	Cl. 2.2.8	Level $\sigma_{fM,c} [N/mm^2]$
9	Pull-through resistance - under the tension load for head of nail - under the tension load for fold of wind rivet - under the tension load for plate of wind rivet	Cl. 2.2.9	Level $F_{t,c} [N]$ $F_{wf,c} [N]$ $F_{wp,c} [N]$
10	Tear resistance under the shear load	Cl. 2.2.10	Level $F_{s,c} [N]$
11	UV stability - residual proportion of characteristic value of tensile strength after weathering	Cl. 2.2.11	Level $\Delta\sigma_{t,c,w} [\%]$

No	Essential characteristic	Assessment method	Type of expression of product performance
12	Resistance to heat - length, width, thickness - deviation of flatness - residual proportion of characteristic value of flexural strength after heat	Cl. 2.2.12	Level $\Delta\epsilon_l$ [%], $\Delta\epsilon_b$ [%], $\Delta\epsilon_d$ [%] $S_{max,h}$ [mm] $\Delta\sigma_{b,c,h}$ [%]
13	Resistance to low temperature - hard body impact resistance at the temperature (-20 ± 2) °C - coefficient of freeze/thaw resistance KM_{f25} [--]	Cl. 2.2.13	Level E [N*m] KM_{f25} [--]
14	Resistance to water penetration	Cl. 2.2.14	Level Pass/Fail
15	Vicat softening temperature (VST)	Cl. 2.2.15	Level VST [°C]
16	Resistance to point loads	Cl. 2.2.16	Level $F_{max,c}$ [N] t_a [mm]

2.2 Methods and criteria for assessing the performance of the product in relation to essential characteristics of the product

This chapter is intended to provide instructions for TABs. Therefore, the use of wordings such as “shall be stated in the ETA” or “it has to be given in the ETA” shall be understood only as such instructions for TABs on how results of assessments shall be presented in the ETA. Such wordings do not impose any obligations for the manufacturer and the TAB shall not carry out the assessment of the performance in relation to a given essential characteristic when the manufacturer does not wish to declare this performance in the Declaration of Performance.

All tests are to be performed at normal laboratory environment (+23 ± 2) °C and RH (50 ± 10) % according to EN ISO 527-1 / 5, if relevant test procedure does not specify other conditions. Test specimens are to be conditioned in relevant environment for 24 hours before the test if test procedure does not specify otherwise.

2.2.1 Reaction to fire

If the product is tested as described below the classification of reaction to fire according to Commission Delegated Regulation (EU) No. 2016/364 and EN 13501-1 is to be performed,

The FPRS is to be tested, using the test method(s) relevant for the corresponding reaction to fire class. For the tests according to EN ISO 11925-2, EN 13823 and EN ISO 1716 (if relevant), the product is tested in a frame as specified in CEN/TS 15447. These standards give only a general description of the arrangement of the test specimen therefore precise specific information about the testing for FPRS is given in the Annex C.

The class of reaction to fire according to Commission Delegated Regulation (EU) No. 2016/364 and EN 13501-1 of the product is given in the ETA.

2.2.2 External fire performance of roofs

The FPRS is to be tested using the test method according to CEN/TS 1187 relevant for the corresponding class of external fire performance to roof according to EN 13501-5. These standards give only a general description of the arrangement of the test specimen therefore precise specific information about the

testing for FPRS are given in Annex C. The build up stage(s) of the FPRS that is/are subject to the test(s) is/are given in the ETA.

If the product is tested as described above, the classification according to EN 13501-5 considering the provisions given by EN 15725 is to be performed.

The class of external fire exposure to roofs of the product is given in the ETA.

2.2.3 Content, emission and/or release of dangerous substances

The performance of the FPRS related to the emissions and/or release and, where appropriate, the content of dangerous substances will be assessed on the basis of the information provided by the manufacturer³ after identifying the release scenarios (in accordance with EOTA TR 034:2015) taking into account the intended use of the product and the Member States where the manufacturer intends his product to be made available on the market.

The identified intended release scenarios for this product and intended use with respect to dangerous substances are:

Use category:

S/W2: Product with indirect contact to soil, ground and surface water.

Cadmium

According to Regulation (EC) No. 1907/2006 (REACH)⁴, the content of cadmium or cadmium compound shall be determined.

According to annex XVII to the Regulation (EC) No. 1907/2006 (REACH) the maximum value of content of cadmium are to be equal or less than 0.01 % per weight.

The test shall be performed according to method A of EN 1122. At least one test specimen shall be tested.

The content of cadmium in milligrams per kilogram of plastic material [mg/kg] shall be given in the ETA.

2.2.4 Hard body impact resistance

The testing of the FPRS for resistance to impact from a hard body is performed as described in ISO 7892 with amendments and modifications as described in Annex B of this EAD. Hard body impact is applied to the exposed surface of the FPRS.

The hard body impact resistance is expressed as impact energy $E [N*m]$, which has caused no damage (no collapse, no penetration, no projection and no degradation) on any of 3 test specimens.

Impact energy $E [N*m]$ that will cause no damage on the FPRS and type of placement are given in the ETA.

³ The manufacturer may be asked to provide to the TAB the REACH related information which he must accompany the DoP with (cf Article 6(5) of Regulation (EU) No. 305/2011).

The manufacturer is not obliged:

- To provide the chemical constitution and composition of the product (or of constituents of the product) to the TAB, or
- To provide a written declaration to the TAB stating whether the product (or constituents of the product) contain(s) substances which are classified as dangerous according to Directive 67/548/EEC and Regulation (EC) No. 1272/2008 and listed in the „Indicative list on dangerous substances“ of the SGDS.

Any information provided by the manufacturer regarding the chemical composition of the products may not be distributed to EOTA or to TABs.

⁴ Regulation (EC) No. 1907/2006 of the European Parliament and of the Council of 18 December 2006 concerning the Registration, Evaluation, Authorisation and Restriction of Chemicals establishing a European Chemicals Agency as amended.

2.2.5 Tensile strength and elongation

The characteristic value of tensile strength and mean value of elongation of material of FPRS shall be determined by testing of at least 5 test specimens Type 2 (as defined in EN ISO 527-3) in accordance with the test method given in EN ISO 527-1, -3 for each direction separately.

After test there shall be calculated for each direction separately:

- characteristic value of tensile strength $\sigma_{t,c}$ [N/mm^2] as 95 % quartile on confidence level 75 % for V_x as unknown according to EN 1990, Annex D, Cl. 7.2
- the bottom limit value of one-sided confidence interval of mean value of the elongation ε [%] at the confidence level 95 % according to ISO 2602, Cl. 6.2.

Characteristic value of tensile strength $\sigma_{t,c}$ [N/mm^2] and the bottom limit value of the one-sided confidence interval of mean value of the elongation ε [%] are given in the ETA for each direction separately.

2.2.6 Dimensions and tolerances

The dimensions (width, length, thickness) of the FPRS shall be determined by measuring according to ISO 23529 using method A for thickness and method C for width and length.

The deviation of flatness shall be determined according to EN 825, Cl. 7.2 and evaluated according to EN 825, Cl. 8. Relevant testing method according to EN 825, Cl. 7.2 shall be chosen with respect to the shape of the material.

Five test specimens at least shall be tested. Three measurements of each dimension on each test specimen shall be performed. The median (ISO 3534-1, Cl. 1.13) of each dimension of all measurements on all test specimens shall be evaluated for each dimension separately.

The two-sided confidence interval of mean value of each dimension separately at the confidence level 95 % according to ISO 2602, Cl. 6.2 shall be calculated with accuracy in integer.

The median of the length l [mm], width b [mm], thickness d [mm] and two-sided confidence interval of relevant dimension are given in the ETA for each dimension separately.

The maximal measured value of deviation of flatness S_{max} [mm] is given in the ETA.

2.2.7 Weight

The product weight shall be determined at least on 5 test specimens for each one separately. Test is to be performed by using scales with accuracy 0,001 kg minimally.

The two-sided confidence interval of mean value of product weight at the confidence level 95 % according to ISO 2602, Cl. 6.2 shall be calculated with accuracy 0,01 kg.

The two-sided confidence interval of mean of product weight m [kg] is given in the ETA.

2.2.8 Flexural strength

The characteristic value of flexural strength of the FPRS shall be determined for each direction separately on 5 test specimens by testing in accordance with the test method A given in EN ISO 178, Cl. 8.7.

The test specimens are prepared from FPRSs. Shape and dimensions of test specimens shall be selected according to EN ISO 178, Cl. 6.1.3. Preparation, control and number of test specimens shall be taken according to EN ISO 178, Cl. 6.3 to 6.5.

In case of anisotropic material (flexural properties depend on the direction) EN ISO 178, Cl. 6.2 shall be followed.

Characteristic value of flexural strength $\sigma_{fM,c}$ [N/mm^2] as 95 % quartile on confidence level 75 % for V_x as unknown according to EN 1990, Annex D, Cl. 7.2 shall be calculated for each direction separately.

Characteristic value of flexural strength $\sigma_{fM,c}$ [N/mm^2] is given in the ETA for each direction separately.

2.2.9 Pull-through resistance

The test methods of a pull-through resistance under the tension load of fixing devices from the FPRS are given in the Annex A, Cl. A.2 to A.3.

These characteristic values of the resistance to pull-through for detailed type of fixing device given as 95 % quartile on confidence level 75 % for V_x as unknown according to EN 1990, Annex D, Cl. 7.2 are given in the ETA:

- under the tension load for nail $F_{t,c}$ [N];
- under the tension load for fold of wind rivet $F_{wf,c}$ [N];
- under the tension load for plate of wind rivet $F_{wp,c}$ [N].

Type and relevant nominal characteristics of fixing devices used for tests of this performance (e.g. dimensions or material characteristics) are given in the ETA.

2.2.10 Tear resistance

The tear resistance under the shear load for nail F_s [N] shall be determined by testing in accordance with the test method given in Annex A, Cl. A.4.

Characteristic value of the tear resistance $F_{s,c}$ [N] given as 95 % quartile on confidence level 75 % for V_x as unknown according to EN 1990, Annex D, Cl. 7.2 for detailed type of fixing device is given in the ETA.

Type and relevant nominal characteristics of fixing device (nail) used for tests of this performance (e.g. dimensions or material characteristics) are given in the ETA.

2.2.11 UV stability

This assessment method relates to Cl. 1.2.2. The UV stability of the FPRS shall be established according to test method selected by manufacturer:

- either by testing of artificial weathering according to the test method given in EN ISO 4892-2, Table 4, Method A (cycle type 4) for a period of 3000 hours (1000 cycles) - see Cl. 2.2.11.1 of EAD, or
- by testing of natural weathering according to EN ISO 877-1 / 7.2 (Method a – open exposure), for 3 years duration of exposure - see Cl. 2.2.11.2 of EAD.

Residual proportion of characteristic value of tensile strength after weathering $\Delta\sigma_{t,c}$ and selected type of weathering (artificial or natural) is given in the ETA.

2.2.11.1 Artificial weathering

The temperature measurement during artificial weathering shall correspond to EN ISO 4892-1 and EN ISO 4892-2. Either a black-standard (BST) or a black-panel (BPT) thermometer may be used. The thermometer used shall be stated in the test report and in the ETA.

The apparatus shall be either an air-cooled or water cooled; exposed Xenon arc weathering device capable of exposing samples in accordance with EN ISO 4892-2. Preparation of test specimens should be in accordance with the general guideline given in EN ISO 4892-2. The samples shall be exposed in accordance to EN ISO 4892-2 for used type of thermometer to the following conditions:

- EN ISO 4892-2, Tab. 3, Method A (cycle type 1) for a period of 3000 hours (1000 cycles) for BST type
- EN ISO 4892-2, Tab. 4, Method A (cycle type 4) for a period of 3000 hours (1000 cycles) for BPT type.

The characteristic value of tensile strength $\sigma_{t,c,wa}$ [N/mm^2] after 1000 cycles of artificial weathering according to EN ISO 4892-2 by test procedure established in Cl. 2.2.5 shall be evaluated.

Residual proportion of characteristic value of tensile strength after weathering (artificial or natural) $\Delta\sigma_{t,c,w}$ is to be determined according to relation:

$$\Delta\sigma_{t,c,w} = \frac{\sigma_{t,c,wa}}{\sigma_{t,c}} \times 100 \quad [\%],$$

where:

- $\Delta\sigma_{t,c,w}$ residual proportion of characteristic value of tensile strength after weathering in %;
 $\sigma_{t,c}$ basic level of characteristic value of tensile strength before weathering in N/mm^2 (level determined by test in 2.2.5);
 $\sigma_{t,c,wa}$ characteristic value of tensile strength after artificial weathering in N/mm^2 .

Calculated residual proportion of characteristic tensile strength in % is to be expressed as integer.

2.2.11.2 Natural weathering

The characteristic tensile strength $\sigma_{t,c,wn}$ [N/mm^2] after direct exposure according to EN ISO 877-1, Cl. 4.2 (Method a – open exposure), for 3 years duration of exposure by test procedure established in Cl. 2.2.5 shall be evaluated.

Residual proportion of characteristic value of tensile strength after weathering $\Delta\sigma_{t,c,w}$ is to be determined according to relation in 2.2.11.1 but except characteristic value of tensile strength after artificial weathering $\sigma_{t,c,wa}$ characteristic value of tensile strength after natural weathering $\sigma_{t,c,wn}$ is to be used.

2.2.12 Resistance to heat

The resistance to heat of the FPRS shall be determined by testing of following characteristics simultaneously:

- change of dimensions (length, width and thickness) by testing according to EN 1604, Cl. 8;
- deviation of flatness of the FPRS by testing according to EN 825, Cl. 8;
- residual proportion of characteristic value of flexural strength $\Delta\sigma_{fM,c,h}$ [N/mm^2] of FPRS by testing of conditioned specimens according to 2.2.8.

Change of dimensions (length, width and thickness) shall be carried out on at least 3 test specimens and other tests shall be carried out at least on 5 test specimens. The test specimens shall be placed to the atmospheric dryer in the horizontal position on the rigid grid.

Conditioning for test of change of dimensions and for test of deviation of flatness shall be at the temperature (70 ± 2) °C and relative humidity (50 ± 5) % for 28 days.

Conditioning for test of flexural strength shall be at the temperature (70 ± 2) °C and relative humidity (50 ± 5) % for (48 ± 1) hours.

Determination of changes of dimensions shall be performed according to EN 1604, Cl. 8. Determination of deviation of flatness shall be performed according to EN 825, Cl. 8.

Characteristic value of flexural strength $\sigma_{fM,c,h}$ [N/mm^2] of FPRS by testing of conditioned specimens according to 2.2.8 shall be evaluated.

Residual proportion of characteristic value of flexural strength after heat $\Delta\sigma_{fM,c,h}$ is to be determined according to relation:

$$\Delta\sigma_{fM,c,h} = \frac{\sigma_{fM,c,h}}{\sigma_{fM,c}} \times 100 \quad [\%],$$

where:

- $\Delta\sigma_{fM,c,h}$ residual proportion of characteristic value of flexural strength after heat in %;
 $\sigma_{fM,c}$ basic level of characteristic value of flexural strength before heat in N/mm² (level determined by test in 2.2.8);
 $\sigma_{fM,c,h}$ characteristic value of flexural strength after heat in N/mm².

Calculated residual proportion of characteristic flexural strength in % is to be expressed as integer.

The determined relative changes of length $\Delta\varepsilon_l$ [%], width $\Delta\varepsilon_b$ [%], thickness $\Delta\varepsilon_d$ [%], deviation of flatness $S_{max,h}$ [mm] and the residual proportion of characteristic value of flexural strength $\Delta\sigma_{fM,c,h}$ [%] after heat are given in the ETA.

2.2.13 Resistance to low temperature

The resistance to low temperature of the FPRS shall be determined by testing of following characteristics simultaneously:

- test of hard body impact resistance at the temperature (-20 ± 2) °C in accordance with the test method given in the Annex B of this EAD;
- determining of coefficient of freeze/thaw resistance of flexural strength KM_{f25} [--] according to EN 14617-5.

The hard body impact resistance at the temperature (-20 ± 2) °C is expressed as impact energy E [N*m], which has caused no damage (no collapse, no penetration, no projection and no degradation) on the FPRS in any of 3 test specimens.

Impact energy E [N*m] which will not cause any damage on the FPRS at the temperature (-20 ± 2) °C is given in the ETA.

5 test specimens according to 2.2.8 at least placed in the chamber in the horizontal position on the rigid grid shall be conditioned according to EN 14617-5. Then the test of flexural strength according to 2.2.8 shall be performed and evaluated.

Coefficient of freeze/thaw resistance KM_{f25} [--] for characteristic value of flexural strength according EN 14617-5, Cl. 8 shall be calculated with basic level of flexural strength determined in 2.2.8.

The coefficient of freeze/thaw resistance of characteristic value of flexural strength at the temperature KM_{f25} [--] is given in the ETA.

2.2.14 Resistance to water penetration

The resistance to water penetration of the FPRS shall be determined by testing in accordance with the test methods given in EN 13111 at the temperature $(+21 \pm 5)$ °C. The resistance to water penetration can be determined by both test methods according to EN 13111, Table 1. The both methods are equivalent for FPRSs. Shape and dimensions of test specimens shall be selected according to EN 13111, Cl. 6. At least 3 test specimens shall be tested.

The resistance to water penetration of product is given in the ETA.

2.2.15 Vicat softening temperature (VST)

The Vicat softening temperature of the FPRS shall be determined by testing in accordance with the test method given in EN ISO 306, Cl. 9, Method B50 on three test specimens at least. Requirements on test specimens are given in EN ISO 306, Cl. 7.

The average value of Vicat softening temperature VST [°C] is given in the ETA.

2.2.16 Resistance to point load

The resistance to point load of the FPRS shall be determined by testing in accordance with the test method given in Annex D of this EAD. This test method is only for self-supporting discontinuous roofing and/or external claddings which are fixed to the laths or grids. At least 5 test specimens shall be tested.

Characteristic value of the maximal load $F_{max,c}$ [N] given as 95 % quartile on confidence level 75 % for V_x as unknown according to EN 1990, Annex D, Cl. 7.2 and thickness t_a [mm] of FPRS tested are given in the ETA.

3 ASSESSMENT AND VERIFICATION OF CONSTANCY OF PERFORMANCE

3.1 System(s) of assessment and verification of constancy of performance to be applied

For the products covered by this EAD with regard to reaction to fire for products covered by this EAD the applicable European legal act is: Decision 1998/436/EC amended by Decision 2001/596/EC.

The AVPC systems are: **1, 3 or 4** (for uses subject to regulations on reaction to fire and depending on the class of reaction to fire according to Regulation (EU) No. 2016/364)

Interpreting the footnotes in the aforementioned EC decision system 1 shall always apply in case of classes A1 to C, because for obtaining one of these classifications the addition of the flame retardants to (or the limitation of organic material in) the form mass is necessary.

In addition, with regard to external fire performance to roof for products covered by this EAD the applicable European legal act is: Decision 1998/436/EC amended by Decision 2001/596/EC.

The AVPC systems are: **3, 4**

In addition, with regard to content, emission and/or release of dangerous substances for products covered by this EAD the applicable European legal act is: Decision 1998/436/EC amended by Decision 2001/596/EC.

The AVPC system is: **3**

For the products covered by this EAD with regard to other application the applicable European legal act is: Decision 1998/436/EC.

The AVCP system is: **3**

3.2 Tasks of the manufacturer

The cornerstones of the actions to be undertaken by the manufacturer of the product in the procedure of assessment and verification of constancy of performance are laid down in Table 2.

Table 2 Control plan for the manufacturer; cornerstones

No	Subject/type of control (product, raw/constituent material, component - indicating characteristic concerned)	Test or control method	Criteria, if any	Minimum number of samples	Minimum frequency of control
Factory production control (FPC) [including testing of samples taken at the factory in accordance with a prescribed test plan]					
1	Reaction to fire	see Cl. 2.2.1	Control plan	1	at modification of product process
2	External fire performance of roofs	see Cl. 2.2.2	Control plan	1	at modification of product process
3	Content of cadmium	see Cl. 2.2.3	Control plan	1	every batch of raw material
4	Hard body impact resistance	see Cl. 2.2.4	Control plan	3	at modification of product process
5	Tensile strength and elongation	see Cl. 2.2.5	Control plan	5	at modification of product process

No	Subject/type of control (product, raw/constituent material, component - indicating characteristic concerned)	Test or control method	Criteria, if any	Minimum number of samples	Minimum frequency of control
6	Dimensions - length, width, thickness - flatness	see Cl. 2.2.6	Control plan	5	1 per week
7	Weight	see Cl. 2.2.7	Control plan	3	1 per week
8	Flexural strength	see Cl. 2.2.8	Control plan	5	at modification of product process
9	Pull-through resistance - under the tension load for head of nail - under the tension load for fold of wind rivet - under the tension load for plate of wind rivet	see Cl. 2.2.9	Control plan	5	at modification of product or used type of nail or wind rivet
10	Tear resistance under the shear load	see Cl. 2.2.10	Control plan	5	at modification of product or used type of nail
11	UV stability - residual proportion of characteristic value of tensile strength after weathering	see Cl. 2.2.11	Control plan	1	at modification of product process
12	Resistance to heat - length, width, thickness - deviation of flatness - residual proportion of characteristic value of Flexural strength after heat	see Cl. 2.2.12	Control plan	5	at modification of product process
13	Resistance to low temperatures - hard body impact resistance at the temperature $(-20 \pm 2) ^\circ\text{C}$ - coefficient of freeze/thaw resistance $KM_{f25} [--]$	see Cl. 2.2.13	Control plan	3	at modification of product process
14	Resistance to water penetration	see Cl. 2.2.14	Control plan	3	at modification of product process
15	Vicat softening temperature (VST)	see Cl. 2.2.15	Control plan	3	at modification of product process
16	Resistance to point loads	see Cl. 2.2.16	Control plan	5	at modification of product process

3.3 Tasks of the notified body

The cornerstones of the actions to be undertaken by the notified body in the procedure of assessment and verification of constancy of performance for FPRS under AVCP system 1 are laid down in Table 3.

Table 3 Control plan for the notified body; cornerstones

No	Subject/type of control (<i>product, raw/constituent material, component</i> <i>- indicating characteristic concerned</i>)	Test or control method	Criteria, if any	Minimum number of samples	Minimum frequency of control
Initial inspection of the manufacturing plant and of factory production control					
1	Initial inspection of the manufacturing plant and of factory production control carried out by the manufacturer regarding the constancy of performance related to reaction to fire and taking into account a limiting of organic material and/ or the addition of fire retardants.	As defined in Cl. 2.2.1 of the EAD	As defined in Cl. 2.2.1 of the EAD	As defined in Cl. 2.2.1 of the EAD	When starting the production
Continuous surveillance, assessment and evaluation of factory production control					
2	Continuous surveillance, assessment and evaluation of factory production control carried out by the manufacturer regarding the constancy of performance related to reaction to fire and taking into account a limiting of organic material and/ or the addition of fire retardants.	As defined in Cl. 2.2.1 of the EAD	As defined in Cl. 2.2.1 of the EAD	As defined in Cl. 2.2.1 of the EAD	once per year

4 REFERENCE DOCUMENTS

- EN 825:2013 Thermal insulating products for building applications - Determination of flatness
- EN 1122:2001 Plastics - Determination of cadmium - Wet decomposition method
- EN 1382:2016 Timber structures - Test methods - Withdrawal capacity of timber fasteners
- EN 1604:2013 Thermal insulating products for building applications - Determination of dimensional stability under specified temperature and humidity conditions
- EN 1990:2002/A1:2005/AC:2010 Eurocode: Basis of structural design
- EN 10230-1:1999 Steel wire nails - Part 1: Loose nails for general applications
- EN 13111:2010 Flexible sheets for waterproofing - Underlays for discontinuous roofing and walls - Determination of resistance to water penetration
- EN 13238:2010 Reaction to fire tests for building products - Conditioning procedures and general rules for selection of substrates
- EN 13501-1:2007+A1:2009 Fire classification of construction products and building elements - Part 1: Classification using test data from reaction to fire tests
- EN 13501-5:2016 Fire classification of construction products and building elements - Part 5: Classification using data from external fire exposure to roofs tests
- EN 13823:2010+A1:2014 Reaction to fire tests for building products - Building products excluding floorings exposed to the thermal attack by a single burning item
- EN 13859-1:2014 Flexible sheets for waterproofing - Definitions and characteristics of underlays - Part 1: Underlays for discontinuous roofing
- EN 14617-5:2012 Agglomerated stone – Test methods – Part 5: Determination of freeze and thaw resistance
- EN 14782:2006 Self-supporting metal sheet for roofing, external cladding and internal lining - Product specification and requirements
- EN 15725:2010 Extended application reports on the fire performance of construction products and building elements
- EN ISO 178:2010/a1:2013 Plastics - Determination of flexural properties
- EN ISO 306:2013 Plastics - Thermoplastic materials - Determination of Vicat softening temperature (VST)
- EN ISO 527-1:2012 Plastics - Determination of tensile properties - Part 1: General principles
- EN ISO 527-3:1995 Plastics - Determination of tensile properties - Part 3: Test conditions for films and sheets
- EN ISO 877-1:2010 Plastics - Methods of exposure to solar radiation - Part 1: General guidance
- EN ISO 1182:2010 Reaction to fire tests for products - Non-combustibility test
- EN ISO 1716:2018 Reaction to fire tests for products - Determination of the cross heat of combustion (calorific value)
- EN ISO 4892-1:2016 Plastics - Methods of exposure to laboratory light sources - Part 1: general guidance
- EN ISO 4892-2:2013 Plastics - Methods of exposure to laboratory light sources - Part 2: Xenon-arc lamps

EN ISO 11925-2:2010/Ac:2011 Reaction to fire tests - Ignitability of building products subjected to direct impingement of flame - Part 2: Single-flame source test

ISO 2602:1980 Statistical interpretation of test results. Estimation of the mean. Confidence interval

ISO 3534-1:2016 Statistics – Vocabulary and symbols – Part 1: General statistical terms and terms used in probability

ISO 7892:1988 Vertical building elements -- Impact resistance tests -- Impact bodies and general test procedures

ISO 23529:2016 Rubber – General procedures for preparing and conditioning test pieces for physical test methods

CEN/TS 1187:2012 Test methods for external fire exposure to roofs

CEN/TS 15447:2006 Mounting and fixing in reaction to fire tests under the Construction Products Directive

EOTA TR 034:2015 General BWR3 Checklist for EADs/ETAs. Dangerous substances

ANNEX A RESISTANCE TO PULL-THROUGH AND TEAR RESISTANCE

A.1 General

This Annex specifies procedures for following tests of resistance of the fixing devices applied with FPRS:

- test of the resistance to pull-through under tension load
- test of the tear resistance under shear load.

The fixing devices shall be installed in accordance with the manufacturer's installation instructions. The tests are to be performed in ambient conditions, until failure occurs. Each test shall be carried out at least on 5 test specimens.

The result of each test is to be expressed in N with accuracy in integer.

The ETA shall contain for each tested combination at least characteristics mentioned below:

- description of used fixing device including:
 - o for nails: type of nail according to EN 10230-1, nominal characteristic diameter, nominal length, type and nominal thickness of coating;
 - o for wind rivet: nominal shape (diameter and thickness) of plate of wind rivet, nominal diameter of wire, material and its mechanical performances, type and nominal thickness of coating;
- the each tested value of resistance, description of failure mode, average and sample standard deviation;
- the characteristic value of resistance given as 95 % quartile on confidence level 75 % for V_x as unknown according to EN 1990, Annex D, Cl. 7.2.

A.2 Resistance to pull-through under tension load for head of nail F_t and/or for fold of wind rivet F_{wf}

The samples (dimensions (250 x 250) mm at least) with fixing devices driven through the centre or middle of the edge are applied as show in Figures A.1 and A.2. The diameter of the supporting ring shall be max. 180 mm. The fixing device is placed in the centre or in the middle of the edge. It depends on manufacturer's installation instructions. The most critical case shall be explained.

An axial tension load is exerted on the fixing device. The speed rate shall be adjusted to 5 mm/min. The force can be applied either by pushing on the head of the fixing device or pulling the end of the fixing device.

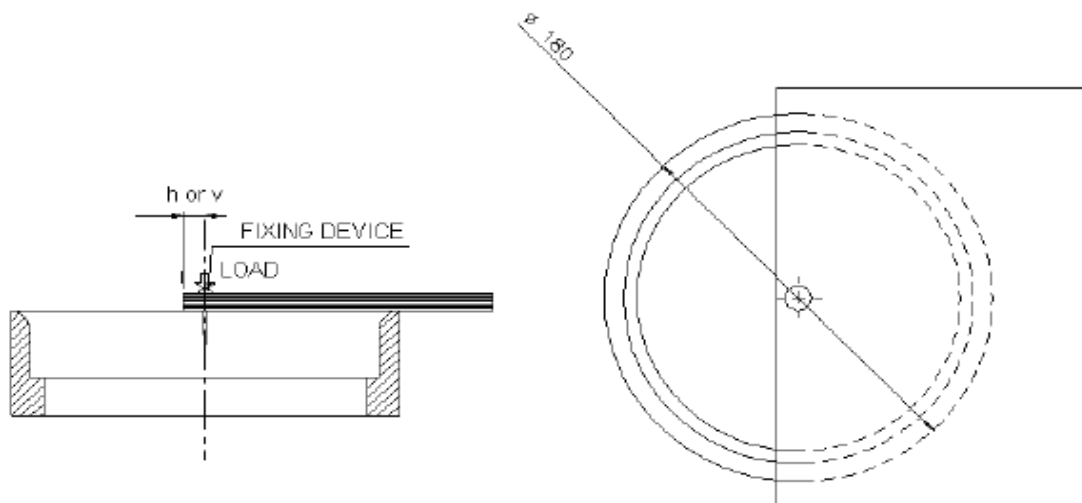

Figure A.1 The fixing device is placed in the middle of the edge

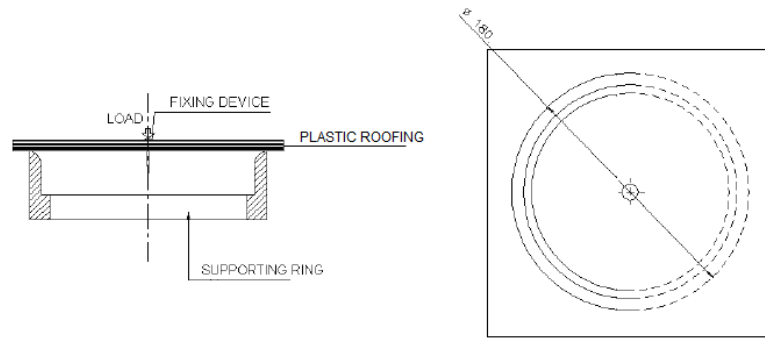

Figure A.2 The fixing device is placed in the centre

A.3 Resistance to pull-through under tension load for plate of wind rivet F_{wp}

The real size FPRS is mechanically fixed to the substrate (e.g. wooden board) according to manufacturer’s installation instructions. The fixing device is applied as it is shown in the Figure A.3. The most critical case shall be explained.

The speed rate shall be adjusted to 5 mm/min.

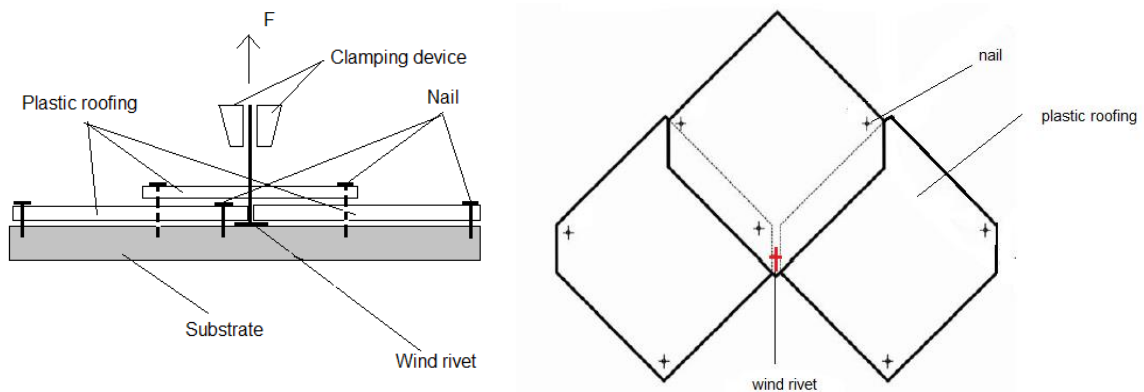

Figure A.3 Resistance to pull-through under tension loads for plate of wind rivet

A.4 Tear resistance under shear load for nail F_s

The samples (dimensions (250x250) mm at least) are mechanically fixed to the substrate (e.g. wooden batten or metal profile) with one fixing device. The fixing device is applied as it is shown in the Figure A.4. The most critical case shall be explained.

The speed rate shall be adjusted to 5 mm/min. Test to destruction shall be performed. During test diagram loading / deformation shall be recorded and maximal loading on destruction shall be registered.

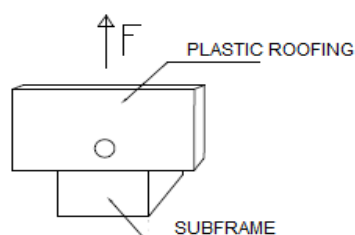

Figure A.4 Resistance to pull-through under shear loads for nail

ANNEX B HARD BODY IMPACT RESISTANCE

The testing of hard body impact resistance of the FPRS is carried out in accordance with the following test procedure. The test shall be carried out at least on 3 test specimens.

The test shall be carried out on one sheet of product and consists of one impact (see Figure B.1).

The test result is expressed as type of damage or “without damage” for impact energy in $N*m$.

The FPRS shall be horizontally positioned on the substrate (wooden board or laths) according to manufacturer’s installation instructions (see Figure B.1). The top edge of the sheet is struck by steel ball at an angle of 90° .

The hard body impactor with mass (m) is dropped from a height (h), so that the total impact energy ($E = g \times h \times m$) corresponds with one of:

- hard body impact (5 $N*m$ up to 10 $N*m$) is carried out with steel ball weighing 1 kg;
- hard body impact (1 $N*m$ to 5 $N*m$) is carried out with steel ball weighing 0,5 kg.

The height is measured between the designated point of impact on surface of test specimen and the bottom of released hard body impactor.

The FPRS is tested at two different ambient temperatures:

- temperature ($+20 \pm 5$) $^\circ C$
- temperature (-20 ± 1) $^\circ C$ (resistance to low temperature).

The presence of any micro cracks or cracks, at the impact point and at the circumference, is noted. The area of the cracked zone is measured and it is noted. The nature of any breakage (e.g. sharp points or edges) is described.

The hard body impact resistance is expressed as total impact energy E [$N*m$] which has not caused damage (no collapse, no penetration, no projection and no degradation) on the FPRS in any of the 3 specimens.

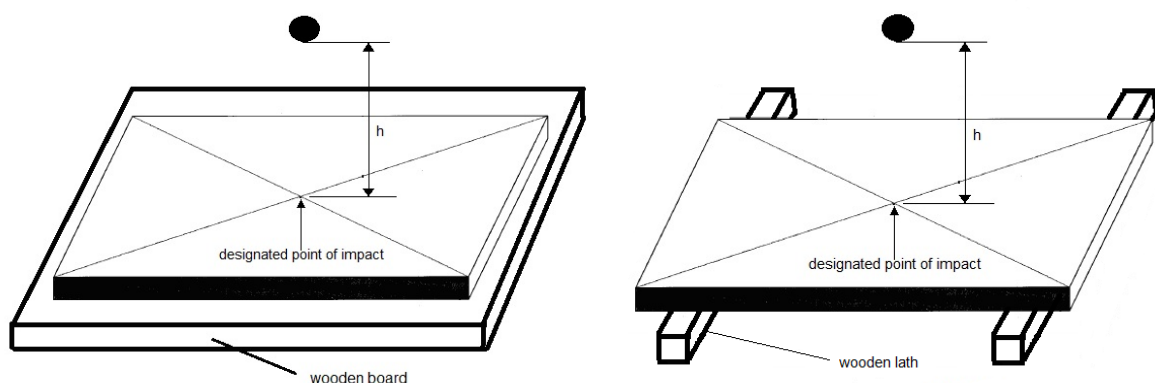

Figure B.1 Assembly for hard body impact test

ANNEX C GUIDANCE FOR TEST OF REACTION TO FIRE ON PLASTIC SHEETS FOR FULLY SUPPORTED DISCONTINUOUS ROOFING AND EXTERNAL CLADDING

This annex covers FPRS according to Cl. 1.1 of the EAD. Product does not contain any coating or finishing on its surface.

C.1 CLASSIFICATION ACCORDING TO REGULATION (EU) NO. 2016/364

C.1.1 General

This part covers testing of reaction to fire according to EN 13501-1 and classification according to Regulation (EU) No. 2016/364.

Test methods and test conditions are to be selected according to EN 13501-1, Cl. 5 and according to corresponding reaction to fire class of the product.

C.1.2 Conditioning

All specimens shall be conditioned according to the provisions given in EN 13238 before testing.

C.1.3 Testing according to EN ISO 1182 and EN ISO 1716

These methods are needed to determine classes A1 and A2 according to EN 13501-1 and Regulation (EU) No. 2016/364.

If required, the specimens shall be prepared and tested according to the provisions given in the test standards EN ISO 1182 and EN ISO 1716.

According to Cl. 5.3 of EN ISO 1182 at least 5 test specimens shall be tested and according to Cl. 7.7 of EN ISO 1716 at least 3 test specimens shall be tested.

Each different basic chemical composition has to be considered when testing. In case of products with the same composition but different volume of inorganic components the variation with the lowest and the highest volume of them shall be tested. If the product contains additionally dosed flame retardant the variation with the lowest volume of the additionally dosed flame retardant shall be tested.

The test result is valid for that variation tested and all variation of the products:

- with the same basic chemical composition,
- with densities between those evaluated,
- of any thickness,
- with volume of inorganic components between those evaluated and
- with higher volume of the same type of additionally dosed flame retardant as the one which has been tested.

C.1.4 Testing according to EN 13823 (SBI)

This method is relevant for determining of the classes A2, B, C and D as well as for the additional classifications s1, s2, s3, d0, d1 and d2 regarding smoke production and flaming droplets.

According to Cl. 5.4 of EN 13823 at least 3 test specimens shall be tested.

According to the rules given in EN 13238 if standard particle board according to EN 13238 is used as substrate for testing it represents end-use substrates made of wood or wood-based materials (minimum thickness and minimum density have to be considered) or any type of substrate of class A1 or A2-s1,d0 in practice. If other substrate according to Cl. 5.3 of EN 13238 on manufacturer's request is applied test result represents relevant type of substrate in practice.

Underlay according to manufacturer's proposition is to be installed in test specimens.

The following test configuration shall be used:

1. The samples (roofing and underlay + substrate) are to be manufactured in the dimensions of the SBI test specimens.
2. Product is to be fixed on substrate mechanically by nails and wind rivets according to manual of manufacturer valid for the lowest declared slope.
3. Test on continuous substrate (e.g. standard particle boards) is recommended.
4. If test on wood laths is applied, product with the smallest dimensions and the heaviest proposed type of lathing are to be used (i.e. proposed type of laths with maximal cross-section dimensions situated in minimal spacing proposed by manufacturer).
5. Sheets exceeding edges of wings are to be cut off on edge lines.
6. Both the short and the long wing of each sample are to be mounted together on the SBI trolley after conditioning. The corner between wings has no other covering.
7. The sample is to be mounted in a distance of 80 mm to the backing board of the SBI apparatus. The cavity behind the sample is to be non-ventilated.

The following parameters of the product shall be taken into account when conducting the SBI tests:

- each different basic chemical composition,
- the greatest and lowest dimensions,
- the greatest and lowest thickness,
- the lowest and highest density,
- the lowest volume of inorganic components and
- the lowest volume of additionally dosed flame retardant.

The test results are valid for the variation tested and any variations of the product

- with the same basic chemical composition,
- with densities between those evaluated,
- all thickness between those evaluated in the tests,
- with volume of inorganic components between those evaluated and
- with higher volume of the same type of additionally dosed flame retardant as the one which has been tested
- test on continuous substrate is valid according to type of substrate and
- test on lathing is valid for proposed type of laths of equal or minor cross-section dimensions situated in equal or larger spacing.

C.1.5 Testing according to EN ISO 11925-2

This method is relevant for determining the reaction to fire classes B, C, D and E of EN 13501-1 and Regulation (EU) No. 2016/364.

Due to the thickness of the roofing material used in practice, the low energy level of the ignition source and the short time of flame exposure the influence of the end use condition can be considered as negligible when testing the specimens. Hence the product shall be tested without any substrate behind.

Testing of all specimens shall be conducted with edge exposure according to Art. 7.3.3.2 of EN ISO 11925-2.

According to Cl. 5.4 of EN ISO 11925-2 at least six test specimens shall be tested. For more details see Cl. 5.4 of EN ISO 11925-2.

The following parameters shall be taken into account when preparing the specimens:

- each different basic chemical composition,
- the greatest and lowest thickness,

- the lowest and highest density,
- the lowest volume of inorganic components and
- the lowest volume of additionally dosed flame retardant.

The test results are valid for the variation tested and any variant of the product:

- with the same basic chemical composition,
- with densities between those evaluated,
- with volume of inorganic components between those evaluated,
- with higher volume of the same type of additionally dosed flame retardant as the one which has been tested and
- with thickness between those evaluated.

C.1.6 Classification according to EN 13501-1 and Regulation (EU) No. 2016/364

Classification of product is to be performed according to Regulation (EU) No. 2016/364.

C.2 CLASSIFICATION ACCORDING TO EN 13501-5

C.2.1 General

This part covers testing and classification of reaction to fire using data from external fire exposure to roofs tests according to EN 13501-5.

Test method and test conditions are to be selected according to EN 13501-5, Art. 6.3 and Art. 6.5 according to manufacturer's requirement on class of reaction to fire using data from external fire exposure to roofs.

Underlay according to manufacturer's declaration is to be installed in test specimens.

C.2.2 Conditioning

All specimens shall be conditioned according to the provisions given in EN 13238 before testing.

C.2.3 Testing according to CEN/TS 1187

Selected type of test shall be performed according to CEN/TS 1187 as follows:

- Test 1 (method with burning brands) according to Cl. 4,
- Test 2 (method with burning brands and wind) according to Cl. 5,
- Test 3 (method with burning brands, wind and supplementary radiant heat) according to Cl. 6,
- Test 4 (method with two stages incorporating burning brands, wind and supplementary radiant heat) according to Cl. 7.

Number of test specimen is given by the above mentioned selected type of test method and specified in relevant clause of CEN/TS 1187.

The following parameters and test configuration shall be taken into account when preparing the specimens:

- type of test selected by manufacturer,
- minimal and maximal slope of roofing proposed by manufacturer,
- fixing of product on substrate valid for tested slope according to manual of manufacturer,
- minimal and maximal dimensions of product,
- minimal and maximal thickness of product,
- each different basic chemical composition,
- the lowest and highest density,

- the lowest volume of inorganic components and
- the lowest volume of additionally dosed flame retardant.

If test on wood lathing is applied, moreover following parameters shall be taken into account:

- maximal permissible span proposed by manufacturer and
- the most lightweight type of lathing proposed by manufacturer (i.e. proposed type of laths with minimal declared cross-section dimensions situated in maximal declared spacing).

Test on continuous substrate (combustible but not treated with fire retardant e.g. standard particle boards) is recommended.

The test results are valid for the variation as tested and any variant of the product:

- with the same basic chemical composition,
- with densities between those evaluated,
- with volume of inorganic components between those evaluated,
- with higher volume of the same type of additionally dosed flame retardant as the one which has been tested
- with smaller span and bigger cross-section of proposed type of lathing (if relevant) and
- with dimensions and thickness of product between those evaluated.

C.2.4 Classification according to EN 13501-5

Classification of product shall be performed according to Cl. 9 EN 13501-5 considering parameters according to Cl. 8 of EN 13501-5.

ANNEX D RESISTANCE TO POINT LOADS

The test of resistance to point load of the FPRS is carried out in accordance with the following test procedure, based on EN 14782. The test shall be carried out at least on 5 test specimens.

The test shall be carried out on one sheet of product (real size of FPRS) with maximal distance of laths and minimal thickness according to Figure D.1.

The FPRS shall be horizontally positioned on the rigid flat supports of width 50 mm in maximum span according to manufacturer's installation instructions (see Figure D.1). The test load is transmitted to FPRS through wooden square pad with dimensions (50 × 50) mm and minimal thickness 80 mm, situated on FPRS in position according to Figure D.1.

The speed rate shall be adjusted to (50±10) N/s.

The maximal load at failure is to be recorded and expressed in *N* with accuracy in integer.

The ETA shall contain for each tested combination at least characteristics mentioned below:

- description FPRS (dimensions, thickness t_a in mm and material);
- distance of rigid flat supports;
- the each tested value of maximal load, description of failure mode, average and standard deviation;
- the characteristic value of maximal force given as 95 % quartile on confidence level 75 % for V_x as unknown according to EN 1990, Annex D, Cl. 7.2.

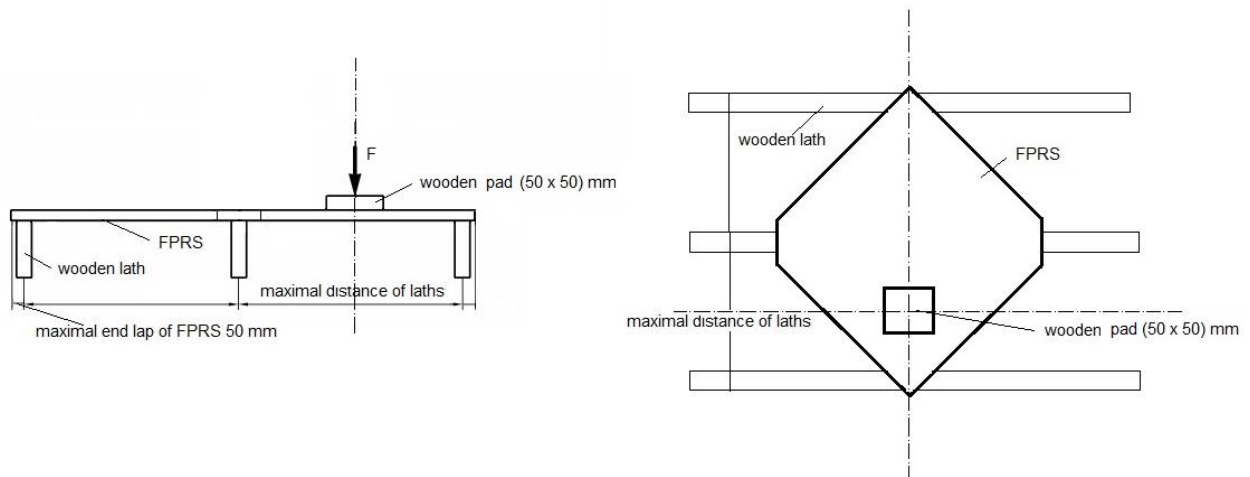

Figure D.1 Arrangement of test of resistance to point load