



www.eota.eu

EAD 130767-00-0603

August 2021

European Assessment Document for

Wood-based dowel-type fasteners



The reference title and language for this EAD is English. The applicable rules of copyright refer to the document elaborated in and published by EOTA.

This European Assessment Document (EAD) has been developed taking into account up-to-date technical and scientific knowledge at the time of issue and is published in accordance with the relevant provisions of Regulation (EU) No 305/2011 as a basis for the preparation and issuing of European Technical Assessments (ETA).

Contents

1	Scope of the EAD	4
1.1	Description of the construction product	4
1.2	Information on the intended use(s) of the construction product	5
1.2.1	Intended use(s)	5
1.2.2	Working life/Durability.....	6
2	Essential characteristics and relevant assessment methods and criteria	8
2.1	Essential characteristics of the product	8
2.2	Methods and criteria for assessing and classification of the performance of the product in relation to essential characteristics of the product	9
2.2.1	Characteristic ultimate bending moment	9
2.2.2	Withdrawal capacity.....	9
2.2.3	Characteristic head pull-through parameter	10
2.2.4	Tensile capacity of the nail	10
2.2.5	Lateral load-carrying capacity	10
2.2.6	Slip modulus of single shear connection	11
2.2.7	Duration of load	12
2.2.8	Durability against biological attack	12
3	Assessment and verification of constancy of performance	13
3.1	System(s) of assessment and verification of constancy of performance to be applied	13
3.2	Tasks of the manufacturer	13
4	Reference documents	14
	Annex A: Determination of k_{mod}	15

1 SCOPE OF THE EAD

1.1 Description of the construction product

This EAD for wood-based dowel-type fasteners, covers nails (in the following referred to as “nails”) made of densified laminated beech wood in timber structures.

In terms of geometry and materials the nails are in accordance with the following requirements:

Nails have smooth or partly profiled shank with a round or rectangular cross-section and will be delivered in loose or collated form. They may or may not have a nail head.

They are produced from densified laminated beech wood in accordance with EN 61061-3-1¹ and with bonding in accordance with clause 3.2 of EN 61061-1.

The assessment methods in this EAD apply to the assessment of nails with a tensile strength f_u of the nail shank of at least 150 N/mm² and with a minimum density of 1100 kg/m³

The dimensions of the nails are given by their length (l) of nail and nominal diameter (d).

Nails either have a head (B) or are used without head. For fasteners with rectangular cross-section, d is the large side dimension.

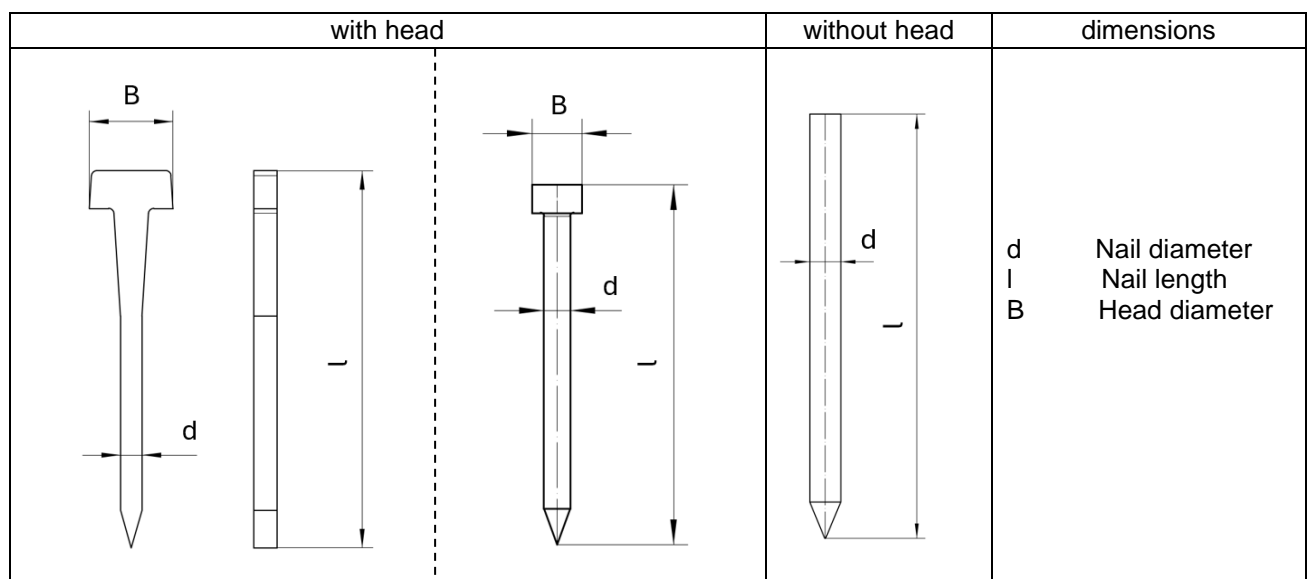

Figure 1.1.1 – Examples of nail dimensions of a wood fibre insulation nail (left and middle) and of a nail without head (right)

Nails covered by this EAD can have a profiled shank.

The characteristics of nails with profiled shank enable its long term and permanent load duration withdrawal capacity.

The product is not covered by the harmonised technical specification EN 14592, since this EN covers only dowel-type fasteners made from steel, therefore some assessment methods are not applicable e.g., torsional strength whereas other characteristics not included in the standard are relevant, e.g., slip modulus. Also, the assessment of durability in the standard is not applicable to dowel-type fasteners made from timber.

Concerning product packaging, transport, storage, maintenance, replacement and repair it is the

¹ All undated references to standards in this document are to be understood as references and dated versions are listed in clause 4

responsibility of the manufacturer to undertake the appropriate measures and to advise his clients on the transport, storage, maintenance, replacement and repair of the product as he considers necessary.

It is assumed that the product will be installed in accordance with the manufacturer's instructions or (in absence of such instructions) according to the usual practice of the building professionals.

Relevant manufacturer's stipulations, e.g., with regard to the intended end use conditions, having influence on the performance of the product covered by this European Assessment Document shall be considered for the determination of the performance and detailed in the ETA as long as the details of the assessment methods as laid down in this EAD are respected.

1.2 Information on the intended use(s) of the construction product

1.2.1 Intended use(s)

The nails are intended to be used in service classes 1, 2 and 3 in accordance with EN 1995-1-1 for short term and medium term as well as long term and permanent load duration for lateral and withdrawal loading in accordance with the definition of EN 1995-1-1. For long and permanent load duration and axial loading, only nails with profiled shank and head are used. In service class 3 only nails with profiled shank or with head are used. The nails are intended to be used for load bearing connections in timber to timber or timber to glued laminated timber, as well as to glued laminated solid timber or to laminated veneer lumber (LVL) or to cross laminated timber. They are driven into timber members perpendicular to grain.

Connected components also may be wood-based panels as OSB, plywood, fibre boards or laminated veneer lumber (LVL) or solid wood panels. Besides those products the connection of gypsum fibre boards, wood fibre boards and wood fibre insulation material with nails are also intended to be used.

d	nominal nail diameter
t	thickness of the supporting structure
t ₁	thickness of the connected component
t ₂	length of the nail in the supporting structure
(l)	length of the nail $l = t_1 + t_2$

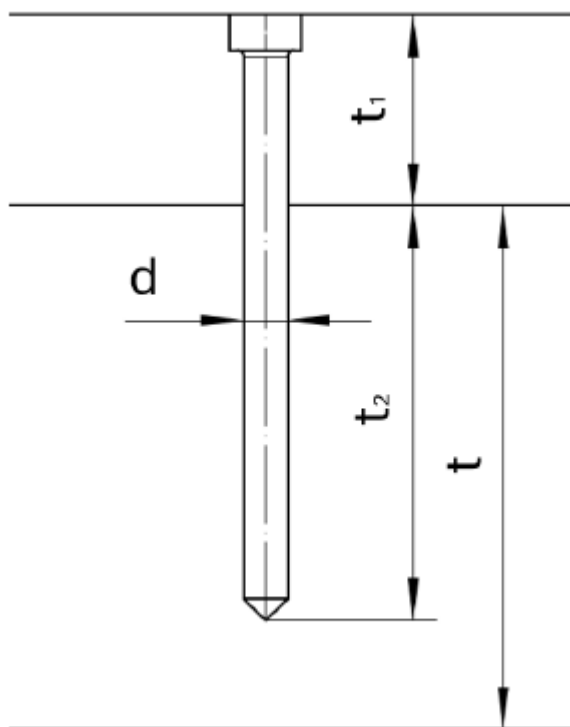

Figure 1.2.1.1 Connection with nail

The assessment methods in this EAD apply only to nails used in connected components with the following dimensions:

Table 1.2.1.1 Thickness of wood and wood-based panels as connected material

Wood or wood-based panel	Minimum thickness in mm	Maximum thickness in mm
Solid timber	24	40
Solid wood panels	15	40
Plywood	15	40
Oriented Strand Boards OSB	15	30
Fibreboards MDF	15	22
Gypsum fibre boards	12.5	15

1.2.2 Working life/Durability

The assessment methods included or referred to in this EAD have been written based on the manufacturer's request to take into account a working life of the nails for the intended use of 50 years when installed in the works (provided that the nailed connections are subject to appropriate installation and maintenance). These provisions are based upon the current state of the art and the available knowledge and experience.

When assessing the product, the intended use and maintenance as foreseen by the manufacturer shall be taken into account. The real working life may be, in normal use conditions, considerably longer without major degradation affecting the basic requirements for works².

² The real working life of a product incorporated in a specific works depends on the environmental conditions to which that works is subject, as well as on the particular conditions of the design, execution, use and maintenance of that works. Therefore, it cannot be excluded that in certain cases the real working life of the product may also be shorter than the assumed working life.

The indications given as to the working life of the construction product cannot be interpreted as a guarantee neither given by the product manufacturer or his representative nor by EOTA when drafting this EAD nor by the Technical Assessment Body issuing an ETA based on this EAD, but are regarded only as a means for expressing the expected economically reasonable working life of the product.

2 ESSENTIAL CHARACTERISTICS AND RELEVANT ASSESSMENT METHODS AND CRITERIA

2.1 Essential characteristics of the product

Table 2.1.1 shows how the performance of the nails is assessed in relation to the essential characteristics.

Table 2.1.1 Essential characteristics of the product and methods and criteria for assessing the performance of the product in relation to those essential characteristics

No	Essential characteristic	Assessment method	Type of expression of product performance
Basic Works Requirement 1: Mechanical resistance and stability			
1	Characteristic ultimate bending moment	2.2.1	Level
2	Withdrawal capacity	2.2.2	Level
3	Characteristic head pull-through parameter	2.2.3	Level
4	Tensile capacity of the nail	2.2.4	Level
5	Lateral load-carrying capacity	2.2.5	Level
6	Slip modulus of single shear connection	2.2.6	Level
Aspects of durability			
7			
8	Duration of load	2.2.7	Level
9	Durability against biological attack	2.2.8	Level

2.2 Methods and criteria for assessing and classification of the performance of the product in relation to essential characteristics of the product

This chapter is intended to provide instructions for TABs. Therefore, the use of wordings such as “shall be stated in the ETA” or “it has to be given in the ETA” shall be understood only as such instructions for TABs on how results of assessments shall be presented in the ETA. Such wordings do not impose any obligations for the manufacturer and the TAB shall not carry out the assessment of the performance in relation to a given essential characteristic when the manufacturer does not wish to declare this performance in the Declaration of Performance.

Testing will be limited only to the essential characteristics which the manufacturer intends to declare. If for any components covered by harmonised standards or European Technical Assessments the manufacturer of the component has included the performance regarding the relevant characteristic in the Declaration of Performance, retesting of that component for issuing the ETA under the current EAD is not required.

2.2.1 Characteristic ultimate bending moment

The characteristic ultimate bending moment of the nails shall be determined by at least 20 tests per diameter in accordance with EN 409 sections 6.1 to 6.4. The load on the nails shall be increased until nail bending failure. The failure loads shall be documented. The tests shall be carried out with a free length of the nail l_2 of $2 \cdot d$.

The specimens shall be conditioned at an equilibrium moisture content corresponding to $(20 \pm 2) ^\circ\text{C}$ and $(85 \pm 5) \%$ relative humidity for at least one week. The samples are conditioned as soon as constant mass is reached. Constant mass is considered to have been achieved if the results of two consecutive weighings carried out at intervals of 6 hours do not differ by more than 0.1 % (mass fraction).

Profiled nails with nail heads shall also be tested after water saturation for 20 days.

The minimum number of specimens is 20 for every nominal diameter or cross-sectional dimension.

The ultimate bending moment is the maximum value in the test. The characteristic value of the ultimate bending moment shall be calculated in accordance with EN 14358.

The characteristic value of the ultimate bending moment shall be stated in the ETA.

2.2.2 Withdrawal capacity

The withdrawal parameter for the tested nail with smooth or profiled shank shall be calculated in accordance with EN 1382. For nails with profiled shank the diameter of the smooth part of the shank shall be used in the calculation of f_{ax} .

The characteristic withdrawal parameter $f_{ax,k}$ shall be determined by tests in accordance with the test method given in EN 1382 and determined in accordance with EN 14358 based on log-normal distribution. The standard for the selection of timber specimens is EN ISO 8970. Tests shall be made with solid timber of softwood in accordance with EN 338/ EN 14081-1 and a characteristic density $\rho_k = 350 \text{ kg/m}^3$ for the supporting material.

At least 20 tests for each different diameter as well as each different kind of shank profile are required.

The test specimens shall be manufactured with the timber at an equilibrium moisture content corresponding to $(20 \pm 2) ^\circ\text{C}$ and $(85 \pm 5) \%$ relative humidity for at least one week. They are conditioned as soon as constant mass is reached. Constant mass is considered to have been achieved if the results of two consecutive weighings carried out at intervals of 6 hours do not differ by more than 0.1 % (mass fraction).

The insertion of dowel-type fasteners shall be in accordance with the manufacturer's instructions. Wood-based dowel-type fasteners shall be driven into the test specimen with fastener axis perpendicular to grain (not parallel) to a penetration of at least $8 \cdot d$ or 20 mm, but not more than $20 \cdot d$ and for fasteners with profiled shank not more than the stated minimum of the length of the profiled shank.

After manufacture, the test pieces shall be stored for at least one week at $(20 \pm 2) ^\circ\text{C}$ and $(65 \pm 5) \%$ relative humidity until constant mass has been reached. Constant mass is considered to have been

achieved if the results of two consecutive weighings carried out at intervals of 6 hours do not differ by more than 0.1 % (mass fraction).

The withdrawal parameter of each test shall be corrected with: $k_p = \rho_k / \rho$.

Where

k_p : correction factor,

ρ_k : characteristic density of the supporting material,

ρ : density of test specimen

The characteristic withdrawal parameter for the tested nail with smooth or profiled shank shall be calculated in accordance with EN 1382 and shall be stated in the ETA.

2.2.3 Characteristic head pull-through parameter

The head pull-through parameter f_{head} shall be determined for nails with head by tests in accordance with the test method given in EN 1383 for all materials in table 1.2.1.1 for which the nails are intended to be used.

At least 20 tests for each different nail diameter and nail head are required.

The characteristic pull-through parameter $f_{head,k}$ shall be determined by tests in accordance with the test method given in EN 1383 and calculated in accordance with EN 14358 based on log-normal distribution.

Characteristic head pull-through parameters determined by tests shall be stated in the ETA with the corresponding characteristic density of the connected material.

2.2.4 Tensile capacity of the nail

The tensile capacity f_{tens} for the tested nail with smooth or profiled shank shall be determined by tests in accordance with EN 1383.

At least 20 tests of the longest nail for each different diameter as well as each different kind of shank profile are required.

The characteristic tensile capacity $f_{tens,k}$ shall be determined by tests in accordance with the test method given in EN 1383 and calculated in accordance with EN 14358 based on log-normal distribution. The characteristic tensile strength $f_{tens,k}$ of longer nails are valid for shorter nails. of the same diameter and shank profile.

The characteristic tensile capacity is given in the ETA.

2.2.5 Lateral load-carrying capacity

The lateral load-carrying capacity $F_{v,Rk}$ shall be determined by compression tests in accordance with the test method given in EN 1380 where the nails are loaded in single shear. The selection of timber specimens is performed in accordance with EN ISO 8970. Tests shall be made with solid timber of softwood in accordance with EN 338/ EN 14081-1 and a characteristic density $\rho_k = 350 \text{ kg/m}^3$ for the supporting material. The spacing, end and edge distances in accordance with section 8.7.2 of EN 1995-1-1 shall be applied for the test specimens.

At least 10 tests for each different diameter, each different kind of shank profile as well as each combination of timber and wood-based panel or gypsum fibre board are required. For timber-to-timber connections, both, tests with loading parallel and perpendicular to grain of the side members shall be performed.

The test specimens shall be manufactured with the timber at an equilibrium moisture content corresponding to $(20 \pm 2) \text{ }^\circ\text{C}$ and $(85 \pm 5) \%$ relative humidity for at least one week. They are conditioned as soon as constant mass is reached. Constant mass is considered to have been achieved if the results of two consecutive weighings carried out at intervals of 6 hours do not differ by more than 0.1 % (mass fraction).

The insertion of dowel-type fasteners shall follow the manufacturer's instructions. Wood-based dowel-type fasteners shall be driven into the test specimens with fastener axis perpendicular to grain (not parallel) to a penetration of at least $4 \cdot d$ in the side member, and at least $8 \cdot d$ in the middle member.

After manufacture, the test pieces shall be stored for at least one week at (20 ± 2) °C and (65 ± 5) % relative humidity.

The lateral load-carrying capacity $F_{v,Rk}$ in conjunction with the characteristic density, minimum spacing, end and edge distances and the diameter of the fasteners is given in the ETA.

2.2.6 Slip modulus of single shear connection

The slip modulus of the wood-based nail in single shear connections shall be determined in accordance with EN 1380 and EN 26891 in grain direction as well as perpendicular to the grain of the timber members. The softwood parts of the specimen shall fulfil the requirements of EN ISO 8970 and shall belong to the strength class C24 in accordance with EN 338.

The slip modulus in conjunction with the characteristic density, minimum spacing, end and edge distances and the diameter of the fasteners shall be given in the ETA.

2.2.7 Duration of load

The influence of duration of load shall be determined by tests in accordance with the test method given in EN 1156 with modifications specified in the Annex A. Contrary to EN 1156/Figure 2, the three-point bending shall be used. Tests shall be made with a representative diameter of the wood-based fastener. The tests are performed in accordance with EN 1156 under the environmental conditions of every service class for which k_{mod} shall be derived. The test specimens will be preconditioned to the equilibrium moisture content for the respective service class in accordance with EN 1156 for the short-term tests as well as for the duration of load tests.

At least 10 tests for the short-term tests and for each stress ratio of 70%, 75%, 80%, 85%, 90% and 95% of the short-term fastener bending capacity are required.

The ETA shall state k_{mod} -values for the nails derived from the duration of load tests, see annex A. For the respective service classes, k_{mod} -values for load duration classes permanent, long-term, medium-term, short-term and very short-term shall be derived from the predicted k_d -values for 50 years, 10 years, 6 months, 1 week or 1 minute, respectively.

2.2.8 Durability against biological attack

The durability against biological attack of the densified beech plywood shall be determined by tests in accordance with the test method given in EN 113-3. The mass loss of the below mentioned basidiomycetes after finishing the test shall be stated in the ETA.

- *Coniophora puteana*
- *Pleurotus ostreatus*
- *Coriolus versicolor*

3 ASSESSMENT AND VERIFICATION OF CONSTANCY OF PERFORMANCE

3.1 System(s) of assessment and verification of constancy of performance to be applied

For the product covered by this EAD the applicable European legal act is: Decision 97/176/EC.

The system is: 3.

3.2 Tasks of the manufacturer

The corner stones of the actions to be undertaken by the manufacturer of the wood-based dowel-type fasteners in the procedure of assessment and verification of constancy of performance are laid down in Table 3.2.1.

Table 3.2.1 Control plan for the manufacturer; corner stones

No	Subject/type of control	Test or control method	Criteria, if any	Minimum number of samples	Minimum frequency of control
Factory production control (FPC) [including testing of samples taken at the factory in accordance with a prescribed test plan]					
1	Checks on incoming materials	Checking of supplier's documentation	According to Control plan	Each consignment	Each delivery
2	Dimensions of the nails	1.1	According to Control plan	According to Control plan	Daily
3	Characteristic ultimate bending moment	2.2.2	Stated \leq characteristic tested	According to Control plan	At least every six months

4 REFERENCE DOCUMENTS

EN 338:2016	Structural timber – Strength classes
EN 409:2009	Timber structures – Test methods – Determination of the yield moment of dowel-type fasteners
EN 636:2012+A1:2015	Plywood – Specifications
EN 1156:2013	Wood-based panels – Determination of duration of load and creep factors
EN 1382:2016	Timber structures – Test methods – Withdrawal capacity of timber fasteners
EN 1383:2016	Timber structures – Test methods – Pull through resistance of timber fasteners
EN 1995-1-1:2004+	
AC:2006+A1:2008+A2:2014	Design of timber structures – Part 1-1: General – Common rules and rules for buildings
EN 14081-1:2016+A1:2019	Timber structures – Strength graded structural timber with rectangular cross section – Part 1: General requirements
EN 14358:2016	Timber structures – Calculation of characteristic 5-percentile s and acceptance criteria for a sample
EN 14592:2008 + A1:2012	Timber structures – Dowel-type fasteners – Requirements
EN 26891:1991	Timber structures; Joints made with mechanical fasteners; General principles for the determination of strength and deformation characteristics
EN 61061-3-1:1998	Non-impregnated densified laminated wood for electrical purposes - Part 3: Specifications for individual materials; Sheet 1: Sheets produced from beech veneer (IEC 61061-3-1:1998);
EN 61061-1:2006	Non-impregnated densified laminated wood for electrical purposes – Part 1: Definitions, designation and general requirements
EN ISO 8970:2020	Timber structures – Testing of joints made with mechanical fasteners – Requirements for wood density (ISO 8970:2010)
EN 113-3:2023	Durability of wood and wood-based products – Wood-based panels – Method of test for determining the resistance against wood-destroying basidiomycetes
EN 1380:2009	Timber structures – Test methods – Load bearing nails, screws, dowels and bolts

ANNEX A: DETERMINATION OF K_{Mod}

To determine k_{mod} for wood-based dowel-type fasteners, EN 1156 is applied as closely as possible. The following notes complement the procedures described in EN 1156 where EN 1156 is not clear or does not apply.

1. Test specimens
Instead of panels with a width of 50 mm, wood-based dowel-type fasteners are directly used as specimens.
2. Dimensions
For fasteners with circular cross-section, the diameter of each fastener shall be determined in the middle of the fastener length both, parallel and perpendicular to the veneer planes of the densified laminated beech wood. The diameter is the average of both measurements.
For fasteners with rectangular cross-section, both cross-sectional dimensions shall be measured in the middle of the fastener length.
3. Test setup
The test to determine both, short-term strength and time-to-failure shall be performed as three-point bending test with a single load in the middle of the span. The longest available fasteners shall be used. The span shall be at least 10 times the fastener diameter or 10 times the cross-sectional dimension, respectively. Half of the fasteners shall be tested with the veneers parallel to the load and half with the veneers perpendicular to the load.
4. Short-term strength
The tests to determine the short-term strength shall be performed as three-point bending tests with a single load in the middle of the span. The short-term strength shall be determined separately for each service class for which k_{mod} is to be derived. The results are short-term strength values, arranged in accordance with increasing strength within each service class. From these values, ratios are calculated for different climate conditions related to different service classes:

$$R_{SC1} = \frac{1}{n} \sum_{i=1}^n \frac{f_{m,i,SC1}}{f_{m,i,SC1}} = 1 \quad R_{SC2} = \frac{1}{n} \sum_{i=1}^n \frac{f_{m,i,SC2}}{f_{m,i,SC1}} \quad R_{SC3} = \frac{1}{n} \sum_{i=1}^n \frac{f_{m,i,SC3}}{f_{m,i,SC1}}$$

Where:

SCX: Environmental conditions related to service class X, $1 \leq X \leq 3$

i: Index of twin specimen

f_m : Bending strength

n: Number of twin samples

5. Duration of load
To determine the duration of load effects for wood-based dowel-type fasteners, a series of tests with loads of 70%, 75%, 80%, 85%, 90% and 95% of the average short-term fastener bending strength for each climate or service class shall be performed. The tests in accordance with section 6.3 and 6.4 of EN 1156 shall be performed under the environmental conditions of every service class for which k_{mod} is to be derived. The test specimens shall be preconditioned to the equilibrium moisture content for the respective climate.
The results are time-to-failure values for each load level SL and service class SC. The time-to-failure values are represented in accordance with Figure 4 in EN 1156. The relative duration of load capacity k_d is determined in accordance with equation (2) in EN 1156 based on linear regression. For the respective service classes, k_d -values for load duration classes permanent, long-term, medium-term, short-term and very short-term shall be derived from the predicted k_d -values for 50 years, 10 years, 6 months, 1 week or 1 minute, respectively.
The k_{mod} values are determined as:

$$k_{mod,SCX,LDY} = R_{SCX} \cdot k_{d,SCX,LDY}$$

Where:

SCX: Environmental conditions related to service class X, $1 \leq X \leq 3$

LDY: load duration, Y = 50 years, 10 years, 6 months, 1 week or 1 minute, respectively