



www.eota.eu

EAD 332795-01-0601

November 2024

European Assessment Document for

Bonded screw fasteners for use in concrete



CE

The reference title and language for the present EAD is English. The applicable rules of copyright refer to the document elaborated in and published by EOTA.

This European Assessment Document (EAD) has been developed taking into account up-to-date technical and scientific knowledge at the time of issue and is published in accordance with the relevant provisions of Regulation (EU) No 305/2011 as a basis for the preparation and issuing of European Technical Assessments (ETA).

Contents

1	Scope of the EAD	5
1.1	Description of the construction product	5
1.2	Information on the intended use of the construction product	5
1.2.1	Intended use.....	5
1.2.2	Working life/Durability.....	8
1.3	Specific terms used in this EAD	8
1.3.1	Abbreviations.....	8
1.3.2	Notation	8
1.3.3	Indices	11
1.3.4	Definitions.....	12
2	Essential characteristics and relevant assessment methods and criteria	13
2.1	Essential characteristics of the product	13
2.2	Methods and criteria for assessing the performance of the product in relation to essential characteristics of the product.....	15
2.2.1	Resistance to steel failure under tension load	15
2.2.2	Resistance to combined pull-out and concrete failure	15
2.2.3	Resistance to concrete cone failure	30
2.2.4	Robustness.....	32
2.2.5	Minimum edge distance and spacing, minimum concrete member thickness (test series F11)	34
2.2.6	Characteristic resistance to concrete splitting under tension load, edge distance to prevent splitting under load (test series F12)	34
2.2.7	Resistance to steel failure under shear load, Characteristic bending moment and ductility factor.....	34
2.2.8	Resistance to tension load for seismic performance category C1	35
2.2.9	Resistance to tension load for seismic performance category C2, displacements	35
2.2.10	Resistance to shear load for seismic performance category C1.....	36
2.2.11	Resistance to shear load for seismic performance category C2, displacements	36
2.2.12	Resistance to shear load under seismic action - Factor for annular gap.....	36
2.2.13	Reaction to fire	36
2.2.14	Fire resistance to steel failure (tension load)	37
2.2.15	Fire resistance to combined pull-out and concrete failure (tension load)	37
2.2.16	Fire resistance to steel failure (shear load)	37
3	Assessment and verification of constancy of performance	38
3.1	System(s) of assessment and verification of constancy of performance to be applied	38
3.2	Tasks of the manufacturer	39
3.3	Tasks of the notified body.....	39
4	Reference documents	41
Annex A	Test programme and general aspects of assessment	42
A1	Test programme	42
A2	General assessment methods	45

1 SCOPE OF THE EAD

1.1 Description of the construction product

This EAD covers post-installed bonded screw fasteners for use in concrete hereinafter referred to as "bonded screw fasteners") placed into pre-drilled holes perpendicular to the surface (maximum deviation 5°) in concrete. This construction product consists of the combination of a concrete screw, which cuts a thread into the concrete, and bonding material. Both components contribute to the functioning of the fastening system.

The products do not consist of more than 1% organic materials (based on weight or volume, whichever is the more onerous).

This construction product cannot be assessed in accordance with other existing EADs, since assessment methods to cover various ranges of combination of both functioning principles is needed. Nevertheless, the different components of the product are defined by EAD 330232-02-0601 [1], clause 1.1 and Figure 1.1.13, for the screw fasteners, and EAD 330499-02-0601 [2], for the bonding material.

The product is not covered by a harmonised European standard (hEN).

The product is not fully covered by EAD 330232-02-0601 [1], EAD 330499-02-0601 [2] and EAD 332795-00-0601 [3]. The bonded screw fasteners may neither be assessed according to EAD 330499-01-0601 [2], because the external thread diameter of the steel element is larger than the drill hole diameter, nor according to EAD 330232-02-0601 [1], because the essential characteristics are different (e.g., combined pull-out and concrete failure, ψ^{0}_{sus} , see clause 2.1).

Compared to the previous version of the EAD, the following changes are introduced:

- Resistance to pull-out failure is given separately for contribution of the concrete screw and the bond material under static and quasi-static tension loading (Clause 2.2.2.15) and under tension load for seismic performance categories C1 and C2 (Clause 2.2.8 and clause 2.2.9).
- Fire resistance to pull-out failure is given for the concrete screw only (Clause 2.2.15).

Concerning product packaging, transport, storage, maintenance, replacement and repair it is the responsibility of the manufacturer to undertake the appropriate measures and to advise his clients on the transport, storage, maintenance, replacement and repair of the product as he considers necessary.

It is assumed that the product will be installed according to the manufacturer's instructions or (in absence of such instructions) according to the usual practice of the building professionals.

Relevant manufacturer's stipulations, e.g., with regard to the intended end use condition, having influence on the performance of the product covered by this European Assessment Document shall be considered for the determination of the performance and detailed in the ETA as long as the details of the assessment methods as laid down in this EAD are respected.

1.2 Information on the intended use of the construction product

1.2.1 Intended use

Bonded screw fasteners are used to connect structural and non-structural elements to structural components.

The fastener is intended to be used:

- in cracked and uncracked concrete (Table 1.2.1.1, options 1 – 6),
- in uncracked concrete only (Table 1.2.1.1, options 7 – 12),
- under static or quasi-static actions,
- under seismic actions (category C1, C2 in accordance with EAD 330232-02-0601 [1], Annex C),
- with requirements related to resistance to fire (only for fasteners in cracked concrete, Table 1.2.1.1, options 1-6),

- with adjustability procedure in accordance with EAD 330011-00-0601 [4], clause 2.2, and the additional requirements provided in this EAD in each relevant test series.

Concrete condition:

- I1 = installation in dry or wet (water saturated) concrete and use in service in dry or wet concrete;
 I2 = installation in water-filled drill holes (not sea water) and use in service in dry or wet concrete.

Water-filled holes are pre-drilled holes (with drilling and cleaning according to the manufacturer's product installation instructions (MPII)), which are afterwards filled with water (e.g., overnight rain in outdoor applications). Underwater installation is different to this condition as the water pressure has to be accounted for. Therefore, the bonded screw fastener is not intended to be used for underwater installations.

Installation direction:

- D1 = downward only,
 D2 = downward and horizontal installation,
 D3 = downward and horizontal and upwards (e.g., overhead) installation.

Installation temperature:

The bonded screw fastener is intended to be used for a range of temperature during installation and curing of the bonding material in the concrete base material between minimum installation temperature not lower than $-40\text{ }^{\circ}\text{C}$ and the maximum installation temperature not higher than $+40\text{ }^{\circ}\text{C}$.

For assessment of installation under freezing condition the manufacturer may choose for the standard variation of temperature or rapid variation of temperature (within a 12-hour period from a low of $0\text{ }^{\circ}\text{C}$ or less to a high of $+24\text{ }^{\circ}\text{C}$ or more) after installation.

Service temperature

The product is intended to be used for service temperature ranges of the concrete base material (anchorage base) during the working life of:

- T1: $24\text{ }^{\circ}\text{C}/40\text{ }^{\circ}\text{C}$ = temperature range from $-40\text{ }^{\circ}\text{C}$ to $+40\text{ }^{\circ}\text{C}$, with a maximum long-term temperature of $+24\text{ }^{\circ}\text{C}$, and a maximum short-term temperature of $+40\text{ }^{\circ}\text{C}$;
 T2: $50\text{ }^{\circ}\text{C}/80\text{ }^{\circ}\text{C}$ = temperature range from $-40\text{ }^{\circ}\text{C}$ to $+80\text{ }^{\circ}\text{C}$, with a maximum long-term temperature of $+50\text{ }^{\circ}\text{C}$, and a maximum short-term temperature of $+80\text{ }^{\circ}\text{C}$;
 T3: $T_{\text{mlt}}/T_{\text{mst}}$ = possible other or additional temperature ranges from $-40\text{ }^{\circ}\text{C}$ to + maximum short-term temperature T_{mst} , with a maximum long-term temperature $T_{\text{mlt}} = 0,6$ to $1,0 T_{\text{mst}}$, and a maximum short-term temperature of $T_{\text{mst}} \geq +40\text{ }^{\circ}\text{C}$ depending of the temperature range the product is intended for.

The maximum short-term temperature T_{mst} and the maximum long-term temperature T_{mlt} shall be assessed for another temperature range T3 only in case of an application of the manufacturer.

Concrete

The product is intended to be used in compacted, reinforced or unreinforced concrete without fibres of strength classes C20/25 to C50/60 in accordance with EN 206 [5] ¹.

The product is intended for the use in hardened concrete which is at least 21 days old.

The bonded screws fasteners are intended to be used in concrete members with a thickness h of:

1. $h \geq 80\text{ mm}$ and $h \geq 1,5 h_{\text{ef}}$ (fasteners intended for use in cracked or uncracked concrete),
2. $h \geq 80\text{ mm}$ and $h \geq 2,0 h_{\text{ef}}$ (fasteners intended for use in uncracked concrete only).

In addition, the thickness of the concrete member in which the fastener is installed is $h \geq h_1 + \Delta h$, where h_1 is the drilling depth and $\Delta h = \max(2 d_0; 30\text{ mm})$.

¹ All undated references to standards in this EAD are to be understood as references to the dated versions listed in chapter 4.

Definitions of the symbols are given in Figure 1.2.1.1 and clause 1.3.2.

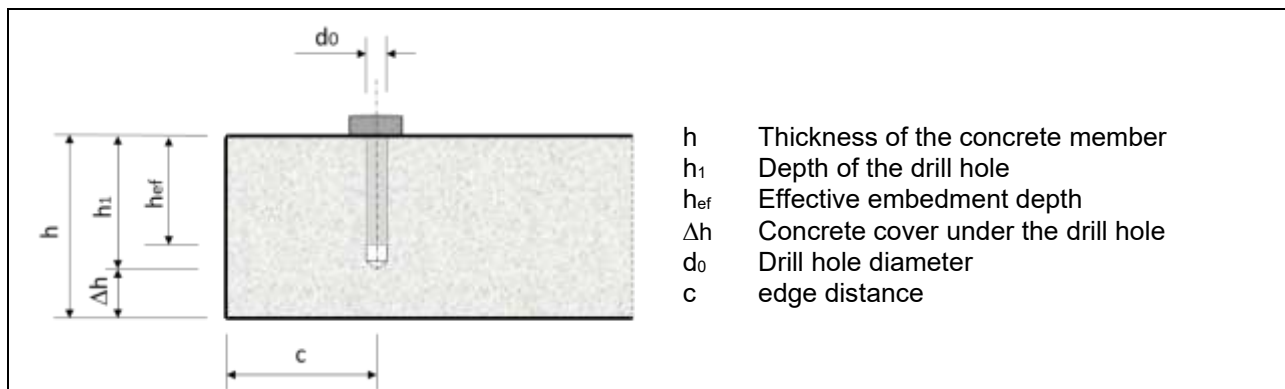

Figure 1.2.1.1 Definitions of dimensions for installation

Performance aspects for calculations of bonded screw fasteners for use in concrete

In this EAD the assessment is made to determine performances of essential characteristics of bonded screw fasteners that can be used for calculations of fastenings for use in concrete in accordance with EN 1992-4 [6] with modifications specified in the EOTA TR 075 [7].

If there are any manufacturer’s product installation instructions (e.g., drilling technology, hole cleaning, installation tools, torque moments), they shall be reported in the ETA.

With regard to the intended use, the manufacturer may choose one of the options given in Table 1.2.1.1.

Table 1.2.1.1 Options for intended use

Option	Cracked concrete	Uncracked concrete	One value for all concrete strength classes	Different values for C20/25 to C50/60	One value for load direction	Separate values for tension and shear capacity	C _{cr} / S _{cr}	C _{min} < C _{cr} / S _{min} < S _{cr}	method in accordance with EN 1992-4 [6] Annex G		
1	✓	✓	x	✓	x	✓	✓	✓	A		
2			✓	x							
3			x	✓							
4			✓	x	✓	x			✓	x	C
5			x	✓							
6			✓	x							
7	x	✓	x	✓	x	✓	✓	x	A		
8			✓	x							
9			x	✓							
10			✓	x	✓	x			✓	x	C
11			x	✓							
12			✓	x							

Bonded screw fasteners are intended for use in fastener groups as defined in EN 1992-4 [6] with product specific modifications indicated in TR 075 [7]. Fasteners covered by this EAD can be used in fastener groups only when criteria for load-displacement behaviours specified in clauses 2.2.2 and 2.2.5 are met.

1.2.2 Working life/Durability

The assessment methods included or referred to in this EAD have been written based on the manufacturer's request to take into account a working life of the bonded screw fasteners for the intended use of 50 years when installed in the works (provided that the bonded screw fasteners are subject to appropriate installation (see 1.1). These provisions are based upon the current state of the art and the available knowledge and experience.

When assessing the product, the intended use as foreseen by the manufacturer shall be taken into account. The real working life may be, in normal use conditions, considerably longer without major degradation affecting the basic requirements for works².

The indications given as to the working life of the construction product cannot be interpreted as a guarantee neither given by the product manufacturer or his representative nor by EOTA when drafting this EAD nor by the Technical Assessment Body issuing an ETA based on this EAD, but are regarded only as a means for expressing the expected economically reasonable working life of the product.

1.3 Specific terms used in this EAD

1.3.1 Abbreviations

C1	= seismic performance category C1 (use in design in accordance with EN 1992-4 [6] C.2)
C2	= seismic performance category C2 (use in design in accordance with EN 1992-4 [6] C.2)
CS	= concrete screw
DM-A	= design method A in accordance with EN 1992-4 [6] Annex G
DM-B	= design method B in accordance with EN 1992-4 [6] Annex G
DM-C	= design method C in accordance with EN 1992-4 [6] Annex G
MPII	= manufacturer's product installation instructions

1.3.2 Notation

A_s	= stressed cross-section of the fastener used for determining the tensile capacity
c	= edge distance
c_{cr}	= edge distance for ensuring the transmission of the characteristic resistance of a single fastener
$c_{cr,N}$	= edge distance for ensuring the transmission of the characteristic resistance in tension of a single fastener without edge and spacing effects in case of concrete cone failure
$c_{cr,sp}$	= edge distance for ensuring the transmission of the characteristic resistance in tension of a single fastener without edge and spacing effects in case of splitting failure

² The real working life of a product incorporated in a specific works depends on the environmental conditions to which that works is subject, as well as on the particular conditions of the design, execution, use and maintenance of that works. Therefore, it cannot be excluded that in certain cases the real working life of the product may also be shorter than referred to above.

$c_{cr,V}$	= edge distance perpendicular to the direction of the shear load for ensuring the transmission of the characteristic resistance in shear of a single fastener without corner, spacing and member thickness effects in case of concrete failure
c_{min}	= minimum allowable edge distance
CV_F	= coefficient of variation [%] related to loads
CV_δ	= coefficient of variation [%] related to displacements
d	= fastener bolt / thread diameter
d_0	= drill hole diameter
d_{cut}	= cutting diameter of drill bit
$d_{cut,m}$	= medium cutting diameter of drill bit (see EAD 330232-02-0601 [1] Table A.3.1.4.1)
$d_{cut,max}$	= cutting diameter at the upper tolerance limit (see EAD 330232-02-0601 [1] Table A.3.1.4.1) (maximum diameter bit)
$d_{cut,min}$	= cutting diameter at the lower tolerance limit (see EAD 330232-02-0601 [1], Table A.3.1.4.1) (minimum diameter bit)
d_f	= diameter of clearance hole in the fixture
d_{nom}	= nominal core diameter of the main load-bearing section
$d_{th,t}$	= external thread diameter of the main load-bearing section of the fastener (concrete screw) used in the test
$d_{th,low}$	= lower limit of external thread diameter of the main load-bearing section of the fastener (concrete screw) according to the specification of the manufacturer
F	= force in general (for the relevant test series N or V applies)
F_{Rk} (N_{Rk}, V_{Rk})	= characteristic resistance given in the ETA
$F_{Rk,5\%}$	= characteristic reference resistance (initial value)
$F_{u,m,t}$	= mean failure load in a test series
$F_{u,m,r}$	= mean failure (ultimate) load in a reference test series
$F_{u,m}$	= mean failure(ultimate) load of a test series
$F_{u,m,20}$	= mean failure (ultimate) load of a test series normalised to concrete strength C20/25
$F_{u,5\%,20}$	= 5%-fractile of failure (ultimate) loads of a test series normalised to concrete strength C20/25
f_c	= concrete compressive strength measured on cylinders
$f_{c,cube}$	= concrete compressive strength measured on cubes with a side length of 150 mm
$f_{c,t}$	= compressive strength of concrete at the time of testing
f_{cm}	= mean concrete compressive strength
f_{ck}	= nominal characteristic concrete compressive strength (based on cylinder)
$f_{ck,cube}$	= nominal characteristic concrete compressive strength (based on cubes)

$f_{u,t}$	= mean ultimate tensile steel strength of the batch for the tested fastener
f_{uk}	= nominal characteristic steel ultimate strength as specified in the technical specification of the manufacturer for the fastener
f_{yk}	= nominal characteristic steel yield strength as specified in the technical specification of the manufacturer for the fastener
h	= thickness of the concrete member
h_{ef}	= effective embedment depth
h_{min}	= minimum thickness of concrete member
h_{nom}	= overall fastener embedment depth in the concrete
h_o	= depth of cylindrical drill hole at shoulder
h_s	= non-load bearing tip of a concrete screw in accordance with Figure 1.1.13 in EAD 330232-02-0601 [1]
h_t	= pitch of the thread of a concrete screw in accordance with Figure 1.1.3 in EAD 330232-02-0601 [1]
h_1	= depth of drilled hole to deepest point
k	= factor for required torque in equation
L	= largest size of the complete product range of each fastener type as supplied to the market
l_f	= effective length of the fastener for transfer of shear load
M	= medium size of the complete product range of each fastener type as supplied to the market
N	= normal force (+N = tension force)
$N_{RK,5\%}$	= baseline values for the assessment of the performance under tension load, 5%-fractile of failure loads in a tension test series
N_{sl}	= load at which uncontrolled slip of the fastener occurs (see Figure A.2.5.1)
$N_{st,m}$	= mean ultimate steel capacity determined from tensile tests on fastener specimens
$N_{u,m}$	= mean ultimate tensile load of the tests in concrete
n	= number of tests of a test series
n_{min}	= minimum number of tests for a test series
$reqd. \alpha$	= required value of α in accordance with Table A.1.1
S	= smallest size of the complete product range of each fastener type as supplied to the market
S_{cr}	= spacing for ensuring the transmission of the characteristic resistance of a single fastener
$S_{cr,N}$	= spacing for ensuring the transmission of the characteristic resistance in tension of a single fastener without edge and spacing effects in case of concrete cone failure

$s_{cr,sp}$	= spacing for ensuring the transmission of the characteristic resistance in tension of a single fastener without edge and spacing effects in case of splitting failure
$s_{cr,V}$	= spacing perpendicular to the direction of the shear load for ensuring the transmission of the characteristic resistance in shear of a single fastener without corner, spacing and member thickness effects in case of concrete failure
s_{min}	= minimum allowable spacing
T	= torque
T_{inst}	= required or maximum recommended setting torque specified by the manufacturer for expansion, installation or pre-stressing of fastener
T_{mit}	= maximum long-term temperature
T_{mst}	= maximum short-term temperature
t_{fix}	= thickness of the fixture
t_u	= time to failure in tests under fire exposure
V	= shear force
α	= reduction factor for load in accordance with A.2.4
α_1	= reduction factor for uncontrolled slip in accordance with A.2.5
β_{cv}	= reduction factor for large scatter in accordance with A.2.2
γ_{inst}	= factor accounting for the sensitivity to installation of post-installed fasteners in accordance with clause 2.2.4 and used in EN 1992-4 [6], clause 4.4.2.1
Δh	= Used for calculation of member thickness, $\Delta h = \max(2 d_0; 30 \text{ mm})$
$\delta_{0,5N_{u,m}}$	= displacement of the fastener at 50% of the mean failure load in a test series
δ_{m1}	= mean fastener displacement after 10^3 crack movements
δ_{m2}	= mean displacement in the repeated load tests after 10^5 load cycles or the sustained load tests after terminating the tests (see EAD 330232-02-0601 [1], 2.2.10; the larger value is decisive)
$\delta_{N_{\infty}}$	= long-term tension displacement
$\delta(\delta_N, \delta_V)$	= displacement (movement) of the fastener at the concrete surface relative to the concrete surface outside the failure area in direction of the load (tension, shear) the displacement includes the steel and concrete deformations and a possible fastener slip
Δw	= required crack width, in addition to the initial hairline crack width as measured after the installation of the fastener
$\Delta\sigma_s$	= working stroke of action in repeated load tests

1.3.3 Indices

CS	= contribution of the concrete screw
B	= contribution of the bond material

<i>cr</i>	= cracked concrete
<i>fi</i>	= fire
<i>r</i>	= reference tests
<i>t</i>	= tested result
<i>u</i>	= ultimate – situation when failure occurs
<i>ucr</i>	= uncracked concrete
20	= related to concrete strength class C20/25
50	= related to concrete strength class C50/60

1.3.4 Definitions

fastener	= a manufactured component for achieving fastening between the base material (concrete) and the fixture; it may consist of assembled components
fastener group	= several fasteners (working together)
fastening	= an assembly comprising base material (concrete), fastener or fastener group and fixture
fixture	= component fixed to the concrete with the use of fasteners
long-term temperature	= temperature of the concrete within the service temperature range, which will be approximately constant over significant periods of time. Long-term temperatures will include constant or near constant temperatures, such as those experienced in rooms that keep a constant temperature or next to heating installations
maximum short-term temperature	= upper limit of the service temperature range
test member	= concrete member in which the fastener is tested
impact screw driver	= electric tool with sudden rotational force for setting and loosening screws

2 ESSENTIAL CHARACTERISTICS AND RELEVANT ASSESSMENT METHODS AND CRITERIA

2.1 Essential characteristics of the product

Table 2.1.1 shows how the performance of the bonded screw fasteners is assessed in relation to the essential characteristics.

Table 2.1.1 Essential characteristics of the product and methods and criteria for assessing the performance of the product in relation to those essential characteristics

No	Essential characteristic	Assessment methods	Type of expression of product performance
Basic Works Requirement 1: Mechanical resistance and stability			
Characteristic resistance to tension load (static and quasi-static loading) Method A			
1	Resistance to steel failure under tension load	2.2.1	Level $N_{Rk,s}$ [kN]
2	Resistance to pull-out and combined pull-out and concrete failure	2.2.2	Level $N_{Rk,p,CS,ucr}^0$, $N_{Rk,p,CS,cr}^0$, $N_{Rk,p,B,ucr}^0$, $N_{Rk,p,B,cr}^0$ [kN], ψ_c , ψ_{sus}^0 [-]
3	Resistance to concrete cone failure	2.2.3	Level $k_{Cr,N}$, $k_{ucr,N}$ [-], h_{ef} , $C_{Cr,N}$ [mm]
4	Robustness	2.2.4	Level γ_{inst} [-]
5	Minimum edge distance and spacing, minimum concrete member thickness	2.2.5	Level c_{min} , s_{min} , h_{min} [mm]
6	Characteristic resistance to concrete splitting under tension load, edge distance to prevent splitting under load	2.2.6	Level $N_{Rk,sp}^0$ [kN], $C_{Cr,sp}$ [mm]
Characteristic resistance to shear load (static and quasi-static loading)			
7	Resistance to steel failure under shear load, characteristic bending moment and ductility factor	2.2.7	Level $V_{Rk,s}^0$ [kN], $M_{Rk,s}^0$ [Nm], k_7 [-]
8	Resistance to pry-out failure	EAD 330232-02-0601 [1], 2.2.8	Level k_8 [-]
Characteristic resistance for simplified design in accordance with EN 1992-4, Annex G			
9	Method B	EAD 330232-02-0601 [1], 2.2.9.1	Level / Level F_{Rk}^0 [kN], C_{Cr} , S_{Cr} [mm]
10	Method C	EAD 330232-02-0601 [1], 2.2.9.2	Level F_{Rk} [kN]
Displacements			
11	Displacements under static and quasi-static loading	EAD 330232-02-0601 [1], 2.2.10	Level δ_{N0} , $\delta_{N\infty}$, δ_{V0} , $\delta_{V\infty}$ [mm]
Characteristic resistance and displacements for seismic performance categories C1 and C2			
12	Resistance to tension load for seismic performance category C1	2.2.8	Level $N_{Rk,s,C1}$, $N_{Rk,p,CS,C1}^0$, $N_{Rk,p,B,C1}^0$ [kN]

No	Essential characteristic	Assessment methods	Type of expression of product performance
13	Resistance to tension load for seismic performance category C2, displacements	2.2.9	Level $N_{Rk,s,C2}$, $N^0_{Rk,p,CS,C2}$, $N^0_{Rk,p,B,C2}$ [kN] $\delta_{N,C2}$ [mm] [-]
14	Resistance to shear load for seismic performance category C1	2.2.10	Level $V_{Rk,s,C1}$, [kN]
15	Resistance to shear load for seismic performance category C2, displacements	2.2.11	Level $V_{Rk,s,C2}$, [kN] $\delta_{V,C2}$ [mm]
16	Factor for annular gap	2.2.12	Level α_{gap} [-]
Basic Works Requirement 2: Safety in case of fire			
17	Reaction to fire	2.2.13	Class
Resistance to fire			
18	Fire resistance to steel failure (tension load)	2.2.14	Level $N_{Rk,s,fi}$ [kN]
19	Fire resistance to pull-out failure (tension load)	2.2.15	Level $N_{Rk,p,CS,fi}$ [kN]
20	Fire resistance to steel failure (shear load)	2.2.16	Level $V_{Rk,s,fi}$ [kN], $M^0_{Rk,s,fi}$ [Nm]
Aspects of durability			
21	Durability	EAD 330232-02-0601 [1], 2.2.20	Description

2.2 Methods and criteria for assessing the performance of the product in relation to essential characteristics of the product

This chapter is intended to provide instructions for TABs. Therefore, the use of wordings such as “shall be stated in the ETA” or “it has to be given in the ETA” shall be understood only as such instructions for TABs on how results of assessments shall be presented in the ETA. Such wordings do not impose any obligations for the manufacturer and the TAB shall not carry out the assessment of the performance in relation to a given essential characteristic when the manufacturer does not wish to declare this performance in the Declaration of Performance.

An overview of the test programme for the assessment of the various essential characteristics of the product is given in Annex A.

Provisions valid for all tests and general aspects of the assessment (determination of 5%-fractile values of resistance, determination of reduction factors, criteria for uncontrolled slip, etc.) are also given in Annex A.

2.2.1 Resistance to steel failure under tension load

2.2.1.1 Steel capacity (test series N1)

Purpose of the assessment and assessment method

EAD 330232-02-0601 [1], clause 2.2.1.1, applies.

Expression of the results

Resistance to steel failure under tension load $N_{Rk,s}$ [kN]

2.2.1.2 Hydrogen embrittlement (test series N3)

EAD 330232-02-0601 [1], clause 2.2.1.3 applies.

2.2.2 Resistance to pull-out and combined pull-out and concrete failure

2.2.2.1 Basic tension tests (test series A1 to A4 and A1(CS) to A4(CS))

Purpose of the assessment

The tests shall be performed to determine the tension capacity of a single fastener without edge influence and thereby the baseline values for the assessment of the performance under tension load $N_{Rk,5\%}$ and for the determination of the displacements δ_{N0} in accordance with EAD 330232-02-0601 [1], 2.2.10.

In addition, with these test lines the contribution of the bonding material to the overall performance of the bonded screw fastener shall be determined. This is required for two reasons: First, the comparison of test results in uncracked concrete allows the critical size and embedment depth to be defined and this will be used in tests for bonding material (Table A.1.1, lines R... and B...). Second, the comparison of test results in each size and embedment depth in both uncracked and cracked concrete will allow the derivation of α_b , in accordance with equation (2.2.2.15.2), for every installation condition applied for by the manufacturer.

Assessment method

These tests shall be performed both with the bonded screw fastener (in accordance with Table A.1.1) and with the concrete screw without the addition of bonding material (in accordance with Table A.1.2).

Test conditions:

EAD 330232-02-0601 [1], clause 2.2.2.1, applies.

If the manufacturer applies for the use of the fastener in uncracked concrete only, the tests in cracked concrete (lines A3, A4, A3(CS), A4(CS)) shall be omitted.

Assessment:

Failure loads

EAD 330232-02-0601 [1], clause 2.2.2.1, applies. Determine ψ_c [-] in accordance with A.2.1.

Assess for each fastener installation condition i (size and embedment depth) the contribution to the overall performance given by the bonding material $\Delta\alpha_{B,i}$ in accordance with equation (2.2.2.1.1). For each size and embedment, the contribution $\Delta\alpha_{B,i}$ shall be calculated separately for uncracked and cracked concrete.

$$\Delta\alpha_{B,i} = \left(1 - \frac{N_{um,CS,i}}{N_{um,i}} \right) \geq 0 \quad (2.2.2.1.1)$$

where

$N_{um,CS,i}$ is the ultimate mean load from Table A1.2, lines A1(CS), A2(CS) for uncracked concrete and lines A3(CS), A4(CS) for cracked concrete, converted to the nominal strength of concrete class C20/25 in accordance with A.2.1. Tests shall be done on the concrete screw without bonding material. Test results with steel failure shall not be considered in the assessment.

$N_{um,i}$ is the ultimate mean load from Table A.1.1, lines A1, A2 for uncracked concrete and lines A3, A4 for cracked concrete, converted to the nominal strength of concrete class C20/25 in accordance with A.2.1. Tests shall be done on the concrete screw with bonding material. Test results with steel failure shall not be considered in the assessment.

Assess the fastener size and embedment depth with $\Delta\alpha_{B,max}$, i.e., the largest value of $\Delta\alpha_{B,i}$ considering the maximum contribution given by the bonding material in uncracked concrete, in accordance with equation (2.2.2.1.2). Such fastener size and embedment depth shall be tested in the sensitivity tests for bonding material and related reference tests as given in Table A.1.1 (test lines R..., B...). If steel failure occurs in both A1 and A2 tests, then the contribution given by the bonding material in cracked concrete shall be considered.

Note: In order to account for the scatter of results and considering the practical cases of subsequent additional assessments (e.g., new sizes, embedment depths, new screw designs,...) the sensitivity tests for bonding material conducted with size and embedment leading to a $\Delta\alpha_{B,ucr}$ that is at most 0,05 below the largest value $\Delta\alpha_{B,max}$, may be used as well for the assessment of pull-out reductions in every combination of size and embedment in uncracked and cracked concrete together with the respective values of $\Delta\alpha_{B,i}$ in accordance with equation (2.2.2.15.1) and (2.2.2.15.2).

Note: The sensitivity tests for bonding material may be performed with more combinations of sizes and embedment depths in addition to the one related to $\Delta\alpha_{B,max}$, including the above mentioned tolerance of 0,05. For the assessment of the untested combinations of size and embedment depth, the reductions obtained with the tested combination of size and embedment related to the next larger value of $\Delta\alpha_{B,ucr}$ shall be considered.

Note: In case of capsule technology the sensitivity for bonding material is assumed to be the same for all sizes only if the chemical composition over the different sizes is the same, e.g., in terms of composition, A-B components ratio. Otherwise, the sensitivity for bonding material shall be assessed separately for every capsule size and embedment with different chemistry.

$$\Delta\alpha_{B,max} = \max (\Delta\alpha_{B,i,ucr}) \quad (2.2.2.1.2)$$

where

$\Delta\alpha_{B,max}$ is the largest contribution to overall performance in uncracked concrete given by the bonding material for all sizes and embedment depths in the scope of the assessment.

$\Delta\alpha_{B,i,ucr}$ is the maximum contribution to overall performance in uncracked concrete given by the bonding material for a fastener installation condition i (size and embedment depth), assessed in accordance with equation (2.2.2.1.1). If steel failure occurs in both A1 and A2 tests, then the contribution given by the bonding material in cracked concrete shall be considered.

Load displacement behaviour

EAD 330232-02-0601 [1], clause 2.2.2.1, applies.

2.2.2.2 Maximum crack width and large hole diameter (test series F1)

Purpose of the assessment and assessment method

The purpose of the test series F1 is to assess α in accordance with clause A.2.4, α_1 in accordance with clause A.2.5 and β_{cv} in accordance with A.2.2 for use in equation (2.2.2.15.1). The reference test for the assessment of α is the test line A3 of Table A.1.1.

2.2.2.3 Maximum crack width and small hole diameter (test series F2)

Purpose of the assessment and assessment method

The purpose of the test series F2 is to assess α in accordance with clause A.2.4, α_1 in accordance with clause A.2.5 and β_{cv} in accordance with A.2.2 for use in equation (2.2.2.15.1). The reference test for the assessment of α is the test line A4 of Table A.1.1.

2.2.2.4 Crack cycling under load (test series F3)

Purpose of the assessment and assessment method

The purpose of the test series F3 is to assess α in accordance with clause A.2.4, α_1 in accordance with clause A.2.5, α_p in accordance with EAD 330232-02-0601 [1], clause 2.2.2.4, and β_{cv} in accordance with A.2.2 for use in equation (2.2.2.15.1). The reference test for the assessment of α is the test line A3 of Table A.1.1.

If the fastener is intended to be used in uncracked concrete only, this test series shall be omitted.

2.2.2.5 Repeated loads (test series F4)

Purpose of the assessment and assessment method

The purpose of the test series F4 is to assess α in accordance with clause A.2.4, α_1 in accordance with clause A.2.5, α_p in accordance with EAD 330232-02-0601 [1], clause 2.2.2.5, and β_{cv} in accordance with A.2.2 for use in equation (2.2.2.15.1). The reference test for the assessment of α is the test line A1 of Table A.1.1.

Tests shall be performed with repeated loads defined in accordance with equations (2.2.2.5.1) and (2.2.2.5.2) in EAD 330232-02-0601 [1]. In case the concrete screw is already assessed in accordance with EAD 330232-02-0601 [1] and the cycling load values to apply are the same, i.e., governing load is based on steel strength, this test series shall be omitted and the test results with the concrete screw alone shall be taken.

2.2.2.6 Torquing in low and high strength concrete and impact screw driver (test series F8)

For torquing in low strength concrete EAD 330232-02-0601 [1], clause 2.2.2.7, applies.

For torquing in high strength concrete EAD 330232-02-0601 [1], clause 2.2.2.8, applies.

For assessment of impact screw driver EAD 330232-02-0601 [1], clause 2.2.2.9, applies.

Purpose of the assessment and assessment method for impact screw driver

The tests are performed to check if steel failure of the concrete screw occurs while setting with impact screw drivers.

The tests shall be omitted if the MPII do not include setting with an impact screw driver.

The test series in high strength concrete is required to check if the concrete screw can be installed without steel failure also in high strength concrete with impact screw driver if test series F7 was omitted.

The test series to be done in the concrete class C20/25 with $d_{cut,max}$ shall be omitted if the test is already performed with the concrete screw alone for an assessment in accordance with EAD 330232-02-0601 [1] and the setting tool with highest power is the same.

However a setting test F8 with concrete class C50/60 and $d_{cut,min}$, with an adjustment process SP1 in accordance with EAD 330011-00-0601, Table 2.3, shall be done at the latest time from fastener setting that is given in the MPII. The purpose of this requirement is to prove the removability of the fastener and still

show that steel failure does not occur in the oversetting of 5 seconds, possibly caused by any pre-damage during the unscrewing procedure. If no time requirement is given in the MPII, then the adjustment process shall be done after a “long curing time” for the bonding material (24h for bonding materials based on resins or 14 days for bonding materials based on cement).

2.2.2.7 Increased temperature (B2 and B3)

Purpose of the assessment

These tests are performed to determine the performance of the bonded screw fastener under increased temperature (maximum short-term temperature and maximum long-term temperature for all temperature ranges according to the intended use) simulating service conditions that vary within the considered temperature range. α_2 and α_3 , shall be established for use in equation (2.2.2.15.2).

Assessment method

Test conditions

Tests conditions to be applied in accordance with EAD 330499-02-0601 [2], clause 2.2.2.9, with the following additions and modifications.

The tests shall be carried out as confined tests in uncracked concrete C20/25 with the fastener size and embedment depth related to $\Delta\alpha_{B,max}$, assessed in accordance with 2.2.2.1.

This test series and the reference tests shall be done with a setup such to prevent steel failure, e.g., by means of reducing the embedment depth. Nevertheless, the specified installation setup given in the MPII shall be kept (in terms of cleaning, mixing and amount of the bonding material). When reducing the embedment depth after the initial setting, the deepest part of the fastener with load-bearing function shall be tested. The tested portion ($h_{nom,red}$) shall be equal to or larger than 30 mm considering only the part of the screw in the effective embedment depth assessed in accordance with clause 2.2.3.2.

It shall be ensured that the wear of the screw thread after setting is representative of the actual application conditions. Therefore, the fastener shall be installed in concrete according to the MPII with the full embedment depth. As an example, a concrete top may be drilled through and used for setting, then removed before the pull-out (see Figure 2.2.2.7.1), e.g., by splitting with hammer and chisel. The screw shall not be removed during the procedure.

The same setup shall be used for each temperature range and reference tests.

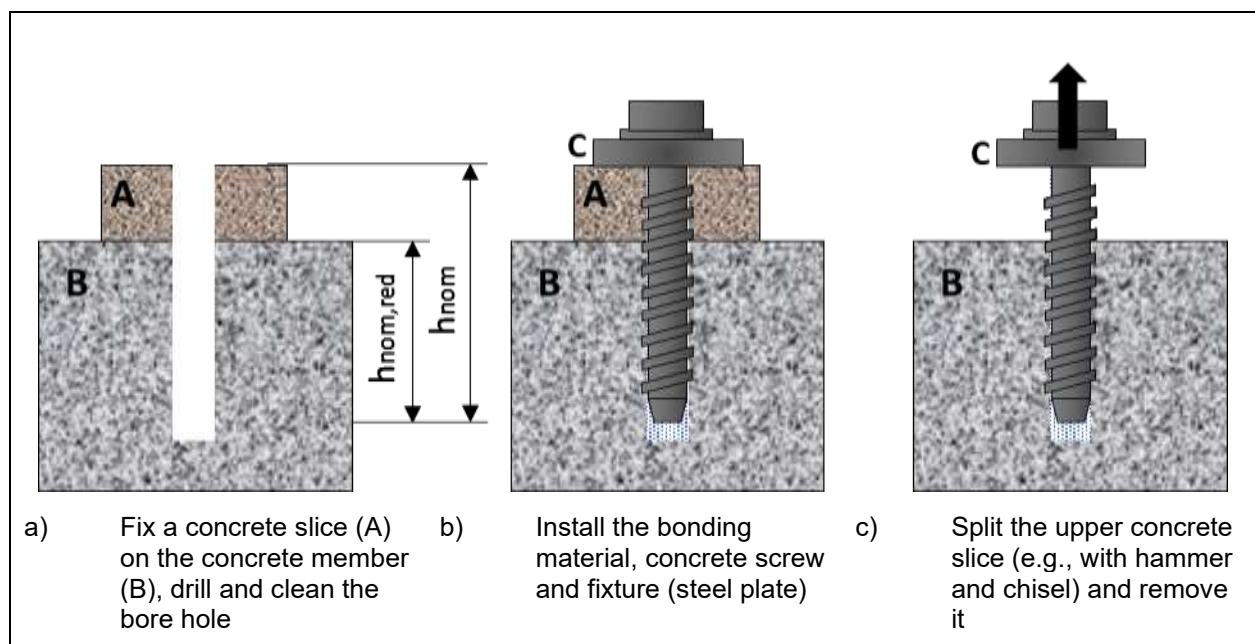

A	Temporary concrete top for drilling, cleaning and installation
B	concrete member
C	Fixture (steel plate) for pull-out test
h_{nom}	overall fastener embedment depth
$h_{nom,red}$	reduced fastener embedment depth to prevent steel failure

Figure 2.2.2.7.1 Test setup to avoid steel failure.

Assessment

Assessment shall be done in accordance with EAD 330499-02-0601 [2], clause 2.2.2.9. The reference tests for this test series shall be done in accordance with the requirements given in Table A.1.1 line A1.

The reduction factors α_2 and α_3 shall be assessed in accordance with equations (2.2.2.9.1) and (2.2.2.9.2) in EAD 330499-02-0601 [2]. These reductions shall be applied for all sizes and embedment depths to the contribution of performance $\Delta\alpha_{B,i}$ given by the bonding material as per equations (2.2.2.15.1) and (2.2.2.15.2).

2.2.2.8 Minimum installation temperature (B4)

Purpose of the assessment

The test shall be done to check sufficient load-bearing capacity at minimum installation temperature at long curing. The minimum installation temperature is 0 °C if not requested by the manufacturer otherwise. β_{cv} , α_1 , and cv_s shall be established for use in equation (2.2.2.15.2).

Assessment method

Test conditions

The tests shall be done in confined setup in uncracked concrete C20/25 at minimum installation temperature specified by the manufacturer or at 0°C when it is not provided.

The tests shall be carried out with the fastener size and embedment depth related to $\Delta\alpha_{B,max}$, assessed in accordance with 2.2.2.1.

The same setup of B2, B3 and reference R1 tests shall be used.

Drill and clean hole according to MPII then cool test member to the minimum installation temperature specified by the manufacturer and the bonding material and embedded part to the lowest fastener component installation temperature specified by the manufacturer or at 0°C when it is not provided. Install the fastener and maintain the temperature of the test member at the lowest installation temperature for 24 h.

If the MPII does not specify otherwise, the concrete member, bonding material and concrete screw shall be conditioned to the minimum installation temperature.

Carry out confined tension test at 24 h while maintaining the temperature of the test member in the area of the embedded part at a distance of 1d from the concrete surface at the specified lowest installation temperature ± 2 K.

Note: The check that the requirement on the temperature in the test member is fulfilled shall be done once and then the temperature shall be kept constant.

Number of tests: $n \geq 5$ tests.

Assessment

The mean failure loads and the 5%-fractile of failure loads, converted to the nominal concrete strength, in tests at the minimum installation temperature and corresponding minimum curing time shall be at least equal to the corresponding values in the reference test R1, at normal ambient temperature after long curing.

If the condition is not fulfilled, the minimum installation temperature shall be increased in order to fulfil the requirement.

The comparison of the 5%-fractile shall be omitted for any number of tests in a test series when the coefficient of variation of the test series is smaller than or equal to the coefficient of variation of the reference test series or if the coefficient of variation in both test series is smaller than 15 %.

Failure loads

- Determine the mean value of failure loads $N_{u,m}$ [kN], converted to the nominal concrete strength in accordance with clause A.2.1.
- Determine the 5%-fractile of the failure loads $N_{5\%}$ [kN], converted to the nominal concrete strength in accordance with clauses A.2.1 and A.2.3.
- Verify the coefficient of variation of failure loads. If the coefficient of variation exceeds 20% ($cv_F > 20\%$), determine the reduction factor for large scatter β_{cv} in accordance with clause A.2.2.

Load displacement

- Determine the reduction factor α_1 in accordance with clause A.2.5.
- Determine the displacements at 50% of the mean failure load $\delta_{0,5N_{u,m}}$ [mm] in each test.
- Determine the coefficient of variation of the displacements at 50% of the mean failure load cv_δ [%]. If the displacements at 50% of the failure load are larger than 0,4 mm, cv_δ shall not exceed 25%. Otherwise, the ETA shall include a sentence: "The displacements of the fasteners are not similar. Significant decrease of resistance to tension load in groups of fasteners may occur."

The minimum installation temperature shall be given in the ETA.

2.2.2.9 Minimum curing time (B5)

Purpose of the assessment

For concrete screws with bonding material, a certain curing time shall be observed before the full combined pull-out and concrete resistance, as assessed in 2.2.2.15 of this EAD, is achieved. The fastener shall be tested right after the curing time specified in the MPII is reached. If no information is provided in the MPII, the test shall be performed immediately after installing the concrete screw.

For bonding material with very short curing time - or in case of a low contribution to the overall performance given by the bonding material - it is possible that the criteria given in this test series are fulfilled immediately after the fastener setting.

The test is required to check sufficient load-bearing capacity after specified minimum curing time. β_{cv} , α_1 , and cv_δ shall be established for use in equation (2.2.2.15.2).

Assessment method

Test conditions

The tests shall be done in unconfined setup in uncracked concrete C20/25 at normal ambient temperature of the concrete member at the corresponding minimum curing time specified by the manufacturer. The tests shall be done also with the minimum installation temperature specified in the MPII. The minimum installation temperature is 0 °C if not requested by the manufacturer otherwise.

The tests shall be carried out with the fastener size and embedment depth related to $\Delta\alpha_{B,max}$, assessed in accordance with 2.2.2.1.

The tests for an assessment about the immediate loading shall be started as soon as possible after the finalization of the concrete screw setting, and not more than 30 seconds after that. The ultimate load in the tests shall be achieved between 1 and 1,5 minutes from the beginning of the tests, i.e., maximum time from end of setting to ultimate load is 2 minutes.

Assessment

The mean failure loads and the 5%-fractile of failure loads measured in tests at the normal ambient temperature and corresponding minimum curing time shall be at least 0,9 times the values measured in reference tests and basic tension tests in accordance with Table A.1.1 with a long curing time (24 h for resins, 14 days for bonding materials based on cement). The mean failure loads and the 5%-fractile of failure loads measured in tests at the minimum installation temperature and corresponding minimum curing time shall be at least equal to the values measured in tests at normal ambient temperature and corresponding minimum curing time. These requirements apply also for the tests at other installation

temperatures and corresponding minimum curing times. If the test is started within 30 seconds after setting, as specified above, and is successful in accordance with the given criteria, the fastener shall be loaded immediately after setting, i.e., no curing time or a curing time of 0 minutes shall be given in the ETA.

If this condition is not fulfilled, then the minimum curing time for a given temperature shall be increased and the corresponding tests shall be repeated.

The comparison of the 5%-fractile shall be omitted for any number of tests in a test series when the coefficient of variation of the test series is smaller than or equal to the coefficient of variation of the reference test series or if the coefficient of variation in both test series is smaller than 15%.

Failure loads

- Determine the mean value of failure loads $N_{u,m}$ [kN], converted to the nominal concrete strength in accordance with clause A.2.1.
- Determine the 5%-fractile of the failure loads $N_{5\%}$ [kN], converted to the nominal concrete strength in accordance with clauses A.2.1 and A.2.3.
- Verify the coefficient of variation of failure loads. If the coefficient of variation exceeds 20% ($CV_F > 20\%$), determine the reduction factor for large scatter β_{cv} in accordance with clause A.2.2.

Load displacement

- Determine the reduction factor α_1 in accordance with clause A.2.5.
- Determine the displacements at 50% of the mean failure load $\delta_{0,5N_{u,m}}$ [mm] in each test.
- Determine the coefficient of variation of the displacements at 50% of the mean failure load cv_δ [%]. If the displacements at 50% of the failure load are larger than 0,4 mm, cv_δ shall not exceed 25%. Otherwise, the ETA shall include a sentence: "The displacements of the fasteners are not similar. Significant decrease of resistance to tension load in groups of fasteners may occur."

2.2.2.10 Sustained loads (R6, B14 and B15)

Purpose of the assessment

The tests shall be performed to check the creep behaviour of the loaded fastener at normal ambient temperature (test series B14) and at maximum long-term temperature (test series B15). Based on these tests for each temperature range the factor $\psi^{0_{sus}}$ accounting for the influence of sustained loads at maximum long-term temperature on the bond strength shall be determined.

The test series at a given temperature shall be omitted if, for the fastener size related to $\Delta\alpha_{B,max}$, assessed in accordance with 2.2.2.1, the following conditions are fulfilled:

- The used concrete screw is already assessed, with the same installation conditions (drilling and cleaning method, drilling diameter, fastener size, embedment depth), in an ETA in accordance with EAD 330232-02-0601 [1], and
- The characteristic pull-out resistance of the concrete screw in uncracked concrete $N_{Rk,ucr,CS}$ as given in the above-mentioned ETA is used as $N^0_{Rk,LT}$ in equation (2.2.2.10.3).

α_Δ , α_1 , $\alpha_{p,\Delta}$ and β_{cv} shall be established for use in equation (2.2.2.15.2).

Assessment method

Test conditions

Tests conditions shall be applied in accordance with EAD 330499-02-0601 [2], clause 2.2.2.6, with the following additions and modifications.

The tests shall be carried out as confined tests in uncracked concrete C20/25 with the fastener size and embedment depth related to $\Delta\alpha_{B,max}$, assessed in accordance with 2.2.2.1.

This test series and the reference tests shall be done with a setup such to prevent steel failure, e.g., by means of reducing the embedment depth. Nevertheless, the specified installation setup given in the MPII shall be kept (in terms of cleaning, mixing and amount of bonding material). When reducing the embedment depth after the initial setting, the deepest part of the fastener shall be tested. The tested portion shall be equal to or larger than 30 mm considering only the part of the screw in the effective embedment depth assessed in accordance with clause 2.2.3.

The same setup shall be used for each temperature range and reference tests.

The sustained load shall be applied to the fastener with the full embedment depth after installation, while for the residual pull-out the embedment depth shall be reduced as described above in order to avoid steel failure.

The permanent load N_{sust} shall be applied by, e.g., a hydraulic jack, springs or dead loads (e.g., applied via a lever arm).

a) Tests at normal ambient temperature (test series R6, B14)

The fasteners shall be installed at normal ambient temperature ($+ 21 \text{ °C} \pm 3 \text{ °C}$).

The fastener shall be loaded to $N_{sust,21}$ in accordance with equation (2.2.2.10.1):

$$N_{sust,21} = \frac{1,1 \cdot N'_{Rk,ucr,21}}{1,5 \cdot \gamma_{inst}} \cdot \frac{1}{1 - \Delta\alpha_{B,max} + \Delta\alpha_{B,max} \cdot (\alpha_2 \cdot \alpha_3 \cdot \alpha_4)} \quad (2.2.2.10.1)$$

where

$N'_{Rk,ucr,21}$ = characteristic combined pull-out and concrete resistance in uncracked concrete for normal ambient temperature, in accordance with equation (2.2.2.15.1)

$\Delta\alpha_{B,max}$ in accordance with equation (2.2.2.1.1).

The load at N_{sust} (maximum variation: -5%) shall be maintained and the temperature at normal ambient temperature shall be maintained and the displacements shall be measured until they appear to have stabilised, but at least for three months. Temperatures in the room may vary by $\pm 3 \text{ °C}$ due to day/night and seasonal effects but the required temperature level of the test member shall be achieved as a mean over the test period. The frequency of monitoring displacements shall be chosen so as to demonstrate the characteristics of the fastener. As displacements are greatest in the early stages, the frequency shall be high initially and reduced with time.

As an example, the following regime is given:

During first hour: every 10 minutes.

During next 6 hours: every hour.

During next 10 days: every day.

From then on: every 5-10 days.

To check the remaining load capacity after the sustained load test, the fastener shall be unloaded and a confined tension test shall be carried out.

The results of the residual load capacity test shall be compared with the load capacity of reference test series R6 at normal ambient temperature.

b) Test at maximum long-term temperature (test series B15)

These tests are not needed for temperature range T1, see clause 1.2.1 (-40 °C to +40 °C), because the effect of the maximum long-term temperature (+24 °C) is tested under normal ambient temperature.

The fasteners shall be installed at normal ambient temperature.

The fastener shall be loaded to $N_{sust,mlt}$ according to equation (2.2.2.10.2).

$$N_{sust,mlt} = \frac{1,1 \cdot N'_{Rk,ucr,mlt}}{1,5 \cdot \gamma_{inst}} \cdot \frac{1}{1 - \Delta\alpha_{B,max} + \Delta\alpha_{B,max} \cdot (\alpha_3 \cdot \alpha_4)} \quad (2.2.2.10.2)$$

where

$N'_{Rk,ucr,mlt}$ = characteristic combined pull-out and concrete resistance in uncracked concrete for maximum long-term temperature, in accordance with equation (2.2.2.15.1)

$\Delta\alpha_{B,max}$ = maximum $\Delta\alpha_{B,i}$ in the assessment of tests in accordance with equation (2.2.2.1.1)

The temperature of the test member shall be raised to reach the maximum long-term temperature at a rate of 5 K per hour in the concrete in the area of the anchorage.

The load at N_{sust} (maximum variation: -5 %) shall be maintained and the temperature at the maximum long-term temperature shall be maintained. For the duration of the tests, the allowed variation of the temperature of the test chamber and the frequency of monitoring displacements in accordance with EAD 330499-02-0601, clause 2.2.2.6 a) applies.

To check the remaining load capacity after the sustained load test, the fastener shall be unloaded and a confined tension test at the maximum long-term temperature shall be carried out.

The results of the residual load capacity test shall be compared with the load capacity of reference test series R6 at maximum long-term temperature.

Assessment

2.2.2.10.1 Displacements in sustained load tests

Assessment shall be conducted in accordance with EAD 330499-02-0601 [2], clause 2.2.2.6.1.

2.2.2.10.2 Residual capacity at normal ambient temperature and maximum long-term temperature

Assessment shall be conducted in accordance with EAD 330499-02-0601 [2], clause 2.2.2.6.2. The reference tests for this test series shall be done in accordance with the requirements given in Table A 1.1, line A1.

The reduction factor α_{Δ} shall be assessed as α in accordance with clause 2.2.2.6.2 in EAD 330499-02-0601 [2].

Use this reduction factor with $rqd.\alpha_{\Delta} = 0,90$ to the contribution of performance $\Delta\alpha_{B,i}$ given by the bonding material in equations (2.2.2.15.1) and (2.2.2.15.2).

2.2.2.10.3 Load displacement behaviour in the residual load tests at normal ambient temperature and maximum long-term temperature

Assessment shall be conducted in accordance with EAD 330499-02-0601 [2], clause 2.2.2.6.3.

2.2.2.10.4 Factor ψ^{0}_{sus} for combined pull-out and concrete failure

The factor ψ^{0}_{sus} accounting for the influence of sustained tension load on the resistance for combined pull-out and concrete failure shall be assessed for working life of 50 years based on test series B14 (clause 2.2.2.10.2) and B15 (clause 2.2.2.10.3). The factor ψ^{0}_{sus} shall be determined for every temperature range according to the intended use for the maximum long-term temperature. Please note that normal ambient temperature corresponds to maximum long-term temperature of temperature range T1.

If the displacement criteria for the extrapolated displacements (clause 2.2.2.10.1) and residual load test requirements (clause 2.2.2.10.2 and clause 2.2.2.10.3) are fulfilled, determine the factor ψ^{0}_{sus} with the applied constant tension load normalized to C20/25 using equation (2.2.2.10.4.1) to (2.2.2.10.4.3). The conversion of failure loads to the nominal concrete strength shall be done in accordance with clause A.2.1.

The basic characteristic long-term bond resistance is assumed to be equal to the tension load applied in the sustained load tests (survival value), which meet the criteria.

$$N_{Rk,LT}^0 = N_{sust} \cdot \min \left(1; \frac{\alpha_{\Delta}}{0,90} \right) \quad (2.2.2.10.4.1)$$

where

$N_{Rk,LT}^0$ = basic characteristic long-term bond resistance at maximum long-term temperature.

N_{sus} = sustained load applied in sustained load tests at maximum long-term temperature, which meet the criteria, normalized to C20/25 concrete strength (in accordance with clause A.2.1).

α_{Δ} = reduction factor as determined in clause 2.2.2.10.2 for the corresponding test series B14 or B15.

The characteristic long-term pull-out resistance shall be determined accounting for the relevant (reduction) factors as follows:

$$N_{Rk,LT} = N_{Rk,LT}^0 \cdot (1 - \Delta\alpha_{B,max} + \Delta\alpha_{B,max} \cdot \alpha_3 \cdot \alpha_4 \cdot k_{sus}) \cdot \min\beta_{cv} \quad (2.2.2.10.4.2)$$

where

$N_{Rk,T}$ = characteristic long-term bond resistance (LT) at maximum long-term temperature for the corresponding temperature range.

$\Delta\alpha_{B,max}$ in accordance with clause 2.2.2.1, equation (2.2.2.1.2).

α_3 = reduction factor in accordance with clause 2.2.2.7.

α_4 = reduction factor in accordance with equation (2.2.2.13.1).

k_{sus} = 1,135.

$\min\beta_{cv}$ = minimum of reduction factors β_{cv} in accordance with clause A.2.2, equation (A.2.2.2).

The factor ψ_{sus}^0 , accounting for the influence of sustained tension load on the characteristic resistance for combined pull-out and concrete failure, shall be then determined as given in equation (2.2.2.10.4.3).

$$\psi_{sus}^0 = \frac{N_{Rk,LT}}{N'_{Rk,p,ucr}} \cdot 1,15 \leq 1,0 \quad (2.2.2.10.4.3)$$

where

ψ_{sus}^0 = reduction factor of long-term characteristic resistance at maximum long-term temperature.

$N'_{Rk,p,ucr}$ = characteristic value of short-term resistance at maximum long-term temperature, for uncracked concrete.

Note: The factor k_{sus} takes account of beneficial effects under long-term loading.

Note: The factor $1,15 = 1,5/1,3 = \gamma_c/\gamma_{c,LT}$ in equation (2.2.2.10.4.3) accounts for the following reduction: the pull-out resistance is determined at the end of the provided service life. Therefore, based on the terminology expressed in EN 1990 [8] the partial factor can be determined assuming a reduced reliability index $\beta = 3,2$ with $\gamma_{c,LT} = 1,3$ compared to the normal value for RC 2, 50 years of service life, $\beta = 3,8$ with $\gamma_c = 1,5$.

2.2.2.11 Freeze/thaw conditions (R7 and B16)

Purpose of the assessment

These tests shall be performed to determine the performance of the fastener under freeze/thaw conditions simulating varying life conditions. The purpose of the test series is to assess α_{Δ} , α_1 , $\alpha_{p,\Delta}$ and β_{cv} for use in equations (2.2.2.15.1) and (2.2.2.15.2).

The test shall be omitted if the fastener is intended to be used in dry internal conditions only.

The test series shall be omitted if, for the fastener size related to $\Delta\alpha_{B,max}$, assessed in accordance with 2.2.2.1, the following conditions are fulfilled:

- The concrete screw is already assessed in accordance with EAD 330232-02-0601 [1], with the same installation conditions (drilling and cleaning method, drilling diameter, fastener size, embedment depth), and
- the characteristic pull-out resistance of the concrete screw in uncracked concrete for C50/60 $N_{Rk,ucr,CS,60}$ derived from the above-mentioned ETA is larger than the N_{sust} given in equation (2.2.2.11.1).

Assessment method

Test conditions

The tests shall be carried out as confined tests in uncracked freeze-thaw resistant concrete C50/60 in accordance with EN 206 [5]. As test member a cube with side length of 180 mm to 300 mm (15d to 25d) or a steel encased concrete cylinder shall be used and splitting of concrete shall be prevented.

The tests shall be performed with the fastener size and embedment depth related to $\Delta\alpha_{B,max}$, assessed in accordance with 2.2.2.1.

This test series and the reference tests shall be done with a setup such to prevent steel failure, e.g., by means of reducing the embedment depth. Nevertheless, the specified installation setup given in the MPII shall be kept (in terms of cleaning, mixing and amount of bonding material). When reducing the embedment depth after the initial setting, the deepest part of the fastener shall be tested. The tested portion shall be equal to or larger than 30 mm considering only the part of the screw in the effective embedment assessed in accordance with clause 2.2.3.

The same setup shall be used for the reference tests.

Cover the top surface of the test member (i.e., the surface where the fastener is installed) with tap water to a depth of at least 12 mm, other exposed surfaces shall be sealed to prevent evaporation of water.

Load fastener to N_{sust} in accordance with equation (2.2.2.11.1).

$$N_{sust} = \frac{N'_{Rk,ucr,60}}{1,5 \cdot 1,4 \cdot \gamma_{inst}} \quad (2.2.2.11.1)$$

where

$N'_{Rk,ucr,60}$ is the combined pull-out and concrete characteristic resistance for uncracked concrete C50/60

γ_{inst} is the factor accounting for the sensitivity to installation of post-installed fasteners in accordance with clause 2.2.4

Carry out 50 freeze/thaw cycles as follows:

- Raise temperature of chamber to $(+20 \pm 2)$ °C within 1 hour, maintain chamber temperature at $(+20 \pm 2)$ °C for 7 hours (total of 8 hours).
- Lower temperature of chamber to (-20 ± 2) °C within 2 hours, maintain chamber temperature at (20 ± 2) °C for 14 hours (total of 16 hours).

If the test is interrupted, the samples shall always be stored at a temperature of (-20 ± 2) °C between the cycles.

The displacements shall be measured continuously during the temperature cycles.

After completion of 50 freeze/thaw cycles as defined above a confined tension test according to EAD 330499-02-0601 [2], Figure D.3.1.4.1 shall be carried out at normal ambient temperature.

Assessment

The rate of displacement increase shall reduce with increasing number of freeze/thaw cycles to a value almost equal to zero. If the test criteria are not fulfilled, the test shall be repeated with a reduced load $N_{sust,red}$. In this case calculate the reduction factor $\alpha_{p,\Delta}$.

Failure loads

- Determine the mean value of failure loads $N_{u,m}$ [kN], converted to the nominal concrete strength in accordance with clause A.2.1.
- Determine the 5%-fractile of the failure loads $N_{5\%}$ [kN], converted to the nominal concrete strength in accordance with clauses A.2.1 and A.2.3.
- Verify the coefficient of variation of failure loads. If the coefficient of variation exceeds 20% ($cv_F > 20\%$), determine the reduction factor for large scatter β_{cv} in accordance with clause A.2.2.
- Determine the reduction factor α_{Δ} in accordance with clause A.2.4 comparing the test results with reference test series in accordance with Table A.1.1, line R7 having the same curing time.
- Use the reduction factor α_{Δ} together with reqd. $\alpha_{\Delta} = 0,9$ in equation (2.2.2.15.2).

Load displacement behaviour

- Determine the reduction factor α_1 in accordance with clause A.2.5.
- Determine the displacements at 50% of the mean failure load $\delta_{0,5N_{u,m}}$ [mm] in each test.

- Determine the coefficient of variation of the displacements at 50% of the mean failure load cv_{δ} [%]. If the displacements at 50% of the failure load are larger than 0,4 mm, cv_{δ} shall not exceed 40%. Otherwise, the ETA shall include a sentence: "The displacements of the fasteners are not similar. Significant decrease of resistance to tension load in groups of fasteners may occur."

2.2.2.12 Installation directions (B17)

Purpose of the assessment

The tests shall be performed to check the performance under unfavourable installation directions. The test series shall be omitted for downward installation only (D1 in accordance with clause 1.2.1). α , α_1 and β_{cv} shall be established for use in equation (2.2.2.15.1).

Assessment method

EAD 330499-02-0601 [2], clause 2.2.2.8, applies with the following modification.

The tests shall be done in unconfined setup. Therefore, the reference test to consider for the assessment is the test series A1 from Table A.1.1.

2.2.2.13 Sensitivity to sulphurous atmosphere and high alkalinity (R8, B18 and B19)

Purpose of the assessment

These tests shall be performed to determine the performance of the fastener under sulphurous atmosphere and under high alkalinity conditions. α_4 shall be established for use in equation (2.2.2.15.2).

Assessment method

Test specimen

The tests shall be performed on the actual system consisting of the concrete screw with bonding material, following the requirements below. For injection systems, tests performed with threaded rods and the factor α_4 assessed in accordance with EAD 330499-02-0601 [2], clause 2.2.2.12, shall be used. The durability reduction factor α_4 shall be directly applied to equation (2.2.2.15.2).

The tests shall be carried out with the fastener size and embedment depth related to $\Delta\alpha_{B,max}$, assessed in accordance with 2.2.2.1.

Note: According to the scope the smallest fastener size that may be tested has diameter 6 with nominal embedment depth of 40 mm. In similar cases the slice thickness may be reduced at most to $3 \cdot d_o$ in order to allow the discard of the installed fastener for at least 10 mm from the concrete surface.

The concrete compressive strength class shall be C20/25. The diameter or side length of the concrete specimen shall be equal to or exceed 150 mm. The test specimen may be manufactured from cubes or cylinders or may be cut from a larger slab. They can be cast; it is also allowed to drill diamond core concrete cylinders from slabs.

One fastener shall be installed per cylinder or cube on the central axis in dry concrete according to the MPII. After curing of the bonding material according to the MPII the concrete cylinders or cubes are carefully sawn into 30 mm thick slices with a diamond saw. The top slice shall be discarded when possible.

To gain sufficient information from the slice tests, at least 30 slices are necessary (10 slices for every environmental exposure test and 10 slices for the comparison tests under normal climate conditions).

Storage of the test specimen under environmental exposure

The slices with the fastener samples shall be subjected to water with high alkalinity and condensed water with sulphurous atmosphere. For comparison tests slices stored under normal climate conditions (dry / +21 °C ± 3 °C / relative humidity 50 ± 5%) for 2000 hours are necessary.

As a consequence of the assumed non-homogeneous load-bearing capacity for concrete screws with bonding material, a given segment of the screw shall be only assessed together with the same portion of the other tested samples and compared to the same portion of the reference fastener samples stored in normal climate conditions. See the example below of two slices sawn per fastener.

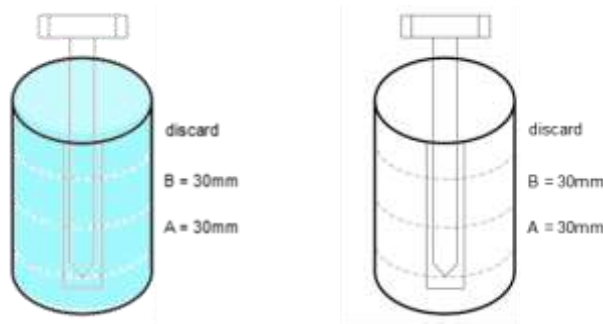

Figure 2.2.2.13.1 Example for cutting fastener samples into slices of 30 mm.

High alkalinity (test series B18)

The slices shall be stored under standard climate conditions in a container filled with an alkaline fluid (pH = 13,2). All slices shall be completely covered for 2000 hours. The alkaline fluid is produced by mixing water with KOH (potassium hydroxide) powder or tablets until the pH-value of 13,2 is reached. The alkalinity of pH = 13,2 shall be kept as stable as possible during the storage and not fall below a value of 13,0. Therefore the pH-value shall be checked and monitored in regular intervals (at least daily). The producing of alkaline fluid by mixing water with KOH (potassium hydroxide) powder or tablets could be given as an example. If other materials are used, then it shall be shown that same results and comparable assessment are achieved.

Sulphurous atmosphere (test series B19)

The tests shall be omitted if the fastener is intended to be used only in internal environmental conditions.

The tests in sulphurous atmosphere shall be performed in accordance with EN ISO 22479 [9]. The slices shall be put into the test chamber. The theoretical sulphurous dioxide concentration shall be 0,67% at the beginning of a cycle. This theoretical sulphur dioxide concentration corresponds to 2 litre of SO₂ for a test chamber volume of 300 litre. At least 80 cycles shall be carried out.

Slice tests

After removal from storage the thickness of the slices shall be measured, and the metal segment of the concrete screws shall be pushed out of the slice in direction from the tip to the screw head, the slice shall be placed centrally to the hole of the confinement steel rig plate. If slices are unreinforced then splitting shall be prevented by external confinement. Care shall be taken to ensure that the loading punch acts centrally on the fastener rod.

The results of at least 10 tests shall be taken for every environmental exposure and for comparison. Results with splitting failure shall be ignored.

Reference test series (test series R8)

The reference test series R8 shall be performed under the same test conditions but the fasteners shall be stored under normal ambient conditions.

Assessment

A possible adverse effect of alkalinity or sulphurous atmosphere on the load-bearing capacity of the fastener shall be taken into account by a reduction factor $\alpha_4 \leq 1,0$ which shall be used in equation (2.2.2.15.2).

The push-through ultimate mean resistance (for the length of 30 mm) of the slices stored in an alkaline liquid shall be compared to the tests on slices stored under normal conditions. For slices stored in sulphurous atmosphere at least 90% of the ultimate mean resistance shall be compared to the tests on slices under normal conditions in accordance with equation (2.2.2.13.1).

$$\alpha_4 = \min \left(1,0; \frac{N_{u,m,B18}}{N_{u,m,r}}; \frac{N_{u,m,B19}}{0,90 \cdot N_{u,m,r}} \right) \quad (2.2.2.13.1)$$

The reference resistance $N_{u,m,r}$ shall be obtained in the test series Table A.1.1, line R8.

The ultimate mean resistance in one slice shall be normalized to 30 mm of slice height with the following relation.

$$N_{Ru,m} = N_{Ru,m,test} \cdot \left(\frac{30}{h_s}\right) \quad (2.2.2.13.2)$$

2.2.2.14 Installation at freezing conditions (B20)

Purpose of the assessment

The tests shall be performed to check the performance of the fastener when installed and cured under freezing conditions to establish the minimum installation temperature in accordance with test series B20 together with the corresponding curing time (test series B4).

The tests shall be omitted if the MPII specify installation in concrete with a minimum installation temperature ≥ 0 °C.

The test series shall be omitted if, for the fastener size related to $\Delta\alpha_{B,max}$, assessed in accordance with 2.2.2.1, the following conditions are fulfilled:

- The concrete screw is already assessed, with the same installation conditions (drilling and cleaning method, drilling diameter, fastener size, embedment depth), in an ETA in accordance with EAD 330232-02-0601 [1], and
- the characteristic pull-out resistance for the concrete screw in uncracked concrete $N_{Rk,ucr,CS}$ is equal or larger than the sustained load to apply in the tests, calculated in accordance with equation (2.2.2.10.1).

Assessment method

Test conditions

Tests conditions shall be applied in accordance with EAD 330499-02-0601 [2], clause 2.2.2.13, with the following modifications.

The tests shall be carried out as confined tests in uncracked concrete C20/25 with the fastener size and embedment depth related to $\Delta\alpha_{B,max}$, assessed in accordance with 2.2.2.1.

This test series and the reference tests shall be done with a setup such to prevent steel failure, e.g., by means of reducing the embedment depth. Nevertheless, the specified installation setup given in the MPII shall be kept (in terms of cleaning, mixing and amount of bonding material). When reducing the embedment depth after the initial setting, the deepest part of the fastener shall be tested. The tested portion shall be equal to or larger than 30 mm considering only the part of the screw in the effective embedment depth assessed in accordance with clause 2.2.3.

The same setup shall be used for the reference tests.

Assessment

EAD 330499-02-0601 [2], clause 2.2.2.13 applies. Perform the pull-out test after sustained load with unconfined test set-up and use test series R6 c) of Table A.1.1 as reference tests.

2.2.2.15 Characteristic resistance to combined pull-out and concrete failure

Purpose of the assessment

Determination of characteristic resistance to combined pull-out and concrete failure.

Assessment method

The initial value $N_{Rk,5\%}$ shall be taken as the 5%-fractile of failure loads in the reference tension test series for uncracked concrete in accordance with Table A.1.1, lines A1 and A2, and for cracked concrete lines A3 and A4. The characteristic tension resistance shall be assessed in accordance with equation (2.2.2.15.1) for each concrete condition, namely uncracked and cracked, and for each temperature range according to the intended use.

The characteristic tension resistance shall be reduced if certain requirements are not met as described in the following:

- α_1 reduction factor for load/displacement behaviour, tension loading (A.2.5).
- α_p reduction factor for crack cycling, repeated load tests (2.2.2.4, 2.2.2.5).
- α reduction factor for residual ultimate load in all tests with a required α (2.2.2.2 to 2.2.2.14).
- β_{cv} reduction factor for scatter of failure loads in all tests (2.2.2.1 to 2.2.2.14).
- α_2 and α_3 reduction factor for increased in-service temperature, according to the relevant temperature range (2.2.2.7).
- α_4 reduction factor for durability (2.2.2.13).
- α_p from sustained load tests, freeze/thaw tests (2.2.2.11).
- α_Δ reduction factor for residual ultimate load from bonding contribution tests (2.2.2.7 to 2.2.2.14).

$$N'_{Rk,p} = N_{Rk,5\%} \cdot \min \left(\min \alpha_p; \min \alpha_1; \min \left(\frac{\alpha}{\text{reqd. } \alpha} \right) \right) \cdot \min \beta_{cv} \cdot \alpha_B \quad (2.2.2.15.1)$$

where

$$\alpha_B = \left((1 - \Delta\alpha_{B,i}) + \Delta\alpha_{B,i} \cdot \alpha_2 \cdot \alpha_3 \cdot \alpha_4 \cdot \min \alpha_{p,\Delta} \cdot \min \left(1; \min \left(\frac{\alpha_\Delta}{\text{reqd } \alpha_\Delta} \right) \right) \right) \quad (2.2.2.15.2)$$

where

$\Delta\alpha_{B,i}$ calculated for the respective fastener size and embedment depth in uncracked and cracked concrete in accordance with equation (2.2.2.1.1)

Note: the reductions from the sensitivity tests for bonding material ($\alpha_2, \alpha_3, \alpha_4, \alpha_p, \alpha_1, \alpha_\Delta$) are assessed at least on the size and embedment leading to $\Delta\alpha_{B,max}$, in accordance with 2.2.2.1. These reductions are then applied to the different values of $\Delta\alpha_{B,i}$ representative of each relevant size and embedment in uncracked or cracked concrete condition.

The characteristic resistance of a fastener in case of pull-out failure in concrete of strength > C20/25 shall be determined by multiplying the characteristic value for concrete C20/25 by a factor ψ_c in accordance with clause A.2.1.

The contribution of the bond material $N_{Rk,p,B,ucr}^0$ to the overall performance of the bonded screw fastener shall be determined by equation (2.2.2.15.3) for uncracked concrete and by equation (2.2.2.15.4) for cracked concrete. As default value, in case no tests for $N_{Rk,p,CS,ucr}^0$ and $N_{Rk,p,CS,cr}^0$ without bond material in accordance with EAD 330232-02-0601 [1], clause 2.2.2, have been performed: $N_{Rk,p,B,ucr}^0 = N'_{Rk,p,ucr}$, $N_{Rk,p,CS,ucr}^0 = 0$ and $N_{Rk,p,B,cr}^0 = N'_{Rk,p,cr}$, $N_{Rk,p,CS,cr}^0 = 0$.

$$N_{Rk,p,B,ucr}^0 = N'_{Rk,p,ucr} - N_{Rk,p,CS,ucr}^0 \quad (2.2.2.15.3)$$

where

$N_{Rk,p,CS,ucr}^0$ corresponds to the characteristic resistance to pull-out failure of the concrete screw without bond material $N_{Rk,p,ucr}$ for uncracked concrete of a single anchor assessed in accordance with EAD 330232-02-0601 [1], clause 2.2.2

$N'_{Rk,p,ucr}$ characteristic resistance to combined pull-out and concrete failure for uncracked concrete of a single anchor, calculated in accordance with (2.2.2.15.1)

$$N_{Rk,p,B,cr}^0 = N'_{Rk,p,cr} - N_{Rk,p,CS,cr}^0 \quad (2.2.2.15.4)$$

where

$N_{Rk,p,CS,cr}^0$ corresponds to the characteristic resistance to pull-out failure of the concrete screw without bond material $N_{Rk,p,cr}$ for cracked concrete of a single anchor assessed in accordance with EAD 330232-02-0601 [1], clause 2.2.2

$N'_{Rk,p,cr}$ characteristic resistance to combined pull-out and concrete failure for cracked concrete of a single anchor, calculated in accordance with (2.2.2.15.1)

The characteristic resistances $N_{Rk,p,CS,ucr}^0$, $N_{Rk,p,B,ucr}^0$, $N_{Rk,p,CS,cr}^0$ and $N_{Rk,p,B,cr}^0$ shall be rounded down accounting for increments as given in Table 2.2.2.15.1.

Table 2.2.2.15.1 Values of characteristic resistance

Range [kN]	Increment [kN]	Example
≤ 10	0,5	3,0 / 3,5 / 4,0 ... 9,5 / 10,0
≤ 20	1,0	11,0 / 12,0 ... 19,0 / 20,0
≤ 50	2,0	22,0 / 24,0 ... 48,0 / 50,0
> 50	5,0	55,0 / 60,0 / 65,0 ...

Expression of the results

Contribution of the concrete screw $N_{Rk,p,CS,ucr}^0$ [kN] and $N_{Rk,p,CS,cr}^0$ [kN] to the overall performance assessed in accordance with EAD 330232-02-0601 [1], clause 2.2.2.

Contribution of the bond material to the overall performance for uncracked concrete $N_{Rk,p,B,ucr}^0$ [kN] as determined by equation (2.2.2.15.3) and for cracked concrete $N_{Rk,p,B,cr}^0$ [kN] as determined by equation (2.2.2.15.4).

Increasing factor for concrete strength ψ_c [-] as determined in clause 2.2.2.1.

Factor for the influence of sustained load ψ_{sus}^0 [-] as determined in clause 2.2.2.10.4.

2.2.3 Resistance to concrete cone failure

2.2.3.1 Resistance to concrete cone failure

Purpose of the assessment

Determination of the characteristic resistance to concrete cone failure.

Assessment method

The determination of the characteristic resistance to concrete cone failure based on compressive cylinder strength of concrete in accordance with clause 7.2.1.4 of EN 1992-4 [6] requires the factors $k_{ucr,N}$ and $k_{cr,N}$. The following factors and characteristic edge distance shall be taken without further testing.

$$k_{ucr,N} = 11,0$$

$$k_{cr,N} = 7,7$$

$$c_{cr,N} = 1,5 h_{ef}$$

h_{ef} = effective embedment depth shall be calculated as $h_{ef,cs}$, (as described in EAD 330232-02-0601 [1], Figure 1.1.13) reported here in equation (2.2.3.1.1), or may be assessed in accordance with clause 2.2.3.2.

$$h_{ef,cs} = 0,85 (h_{nom} - 0,5h_t - h_s) \leq 8d_0 \quad (2.2.3.1.1)$$

2.2.3.2 Effective embedment depth (test series A5)

The purpose of the assessment is to prove an effective embedment depth equal to the nominal embedment depth of the bonded screw fastener, excluding any screw tip without thread ($h_{ef} = h_{nom} - h_s$).

This test series shall be performed to check whether a group of 4 fasteners shows a concrete cone resistance larger than the default value, i.e., the concrete cone capacity for a group of anchors calculated in accordance with EN 1992-4 [6], clause 7.2.1.4, using h_{ef} as defined in accordance with equation (2.2.3.1.1).

Assessment method**Test conditions**

These tests shall be performed in uncracked concrete with concrete classes C20/25 and C50/60. The drill bit diameter $d_{\text{cut,med}}$ shall be used in the tests. Test all sizes.

The distance between the support of the testing rig and each fastener in the group shall be larger than $2 \cdot (h_{\text{nom}} - h_s)$. Therefore, in case of a circular support ring of the testing rig, the internal diameter shall fulfil the requirement given in equation (2.2.3.2.1).

$$d_{\text{support}} \geq 4 \cdot (h_{\text{nom}} - h_s) + s_{1,2} \cdot \sqrt{2} \quad (2.2.3.2.1)$$

The bonded screw fasteners shall be installed at the given nominal embedment depth h_{nom} as a quadruple group with equal spacings $s_1 = s_2 = \max(0,5 \cdot (h_{\text{nom}} - h_s); s_{\text{min}})$. The tension test until failure shall be carried out as unconfined test setup in accordance with Annex A. At least a total of 10 tests with quadruple fastener groups shall be performed with a minimum of 5 tests for each concrete class.

Assessment

The tests performed in C20/25 and C50/60 shall be assessed jointly, converting the failure loads to a nominal compressive strength of the concrete $f_c = 20$ MPa in accordance with equation (A.2.1.1).

- Determine the mean failure load $N_{\text{um,A5,20}}$ of the quadruple fasteners group in the test series. Determine the theoretical concrete cone capacity $N_{\text{um,c,r}}$ in accordance with equation (2.2.3.2.3) with the effective embedment depth h_{ef}^0 taken in accordance with equation (2.2.3.2.2).

$$h_{\text{ef}}^0 = h_{\text{nom}} - h_s \quad (2.2.3.2.2)$$

$$N_{\text{um,c,r}} = \left(\frac{3 \cdot (h_{\text{ef}}^0) + s}{3 \cdot (h_{\text{ef}}^0)} \right)^2 \cdot 14,6 \cdot \sqrt{20} \cdot (h_{\text{ef}}^0)^{1,5} \quad (2.2.3.2.3)$$

- For the assessment the mean failure load in the test series and the theoretical mean concrete cone capacity shall be compared. If a level of resistance equal to or larger than 90% of the default value is achieved as shown in equation (2.2.3.2.4), an effective embedment depth equal to $h_{\text{nom}} - h_s$ is confirmed.

$$N_{\text{u,m,A5,20}} \geq 0,90 \cdot N_{\text{um,c,r}} \quad (2.2.3.2.4)$$

- If the criteria above are not fulfilled, the factor α_{hef} shall be derived in accordance with equation (2.2.3.2.6) and intermediate values of effective embedment depth shall be assessed following the equation (2.2.3.2.5).
- Verify the coefficient of variation of failure loads. If the coefficient of variation exceeds 15%, the effective embedment depth in accordance with equation (2.2.3.1.1) shall be taken.

$$h_{\text{ef}} = \max(\alpha_{\text{hef}} \cdot h_{\text{nom}}; h_{\text{ef,cs}}) \quad (2.2.3.2.5)$$

$$\alpha_{\text{hef}} = \frac{N_{\text{um,A5,20}}}{N_{\text{um,c,r} \cdot 0,9}} \cdot a + b \quad \text{with } 0,85 \leq \alpha_{\text{hef}} \leq 1 \quad (2.2.3.2.6)$$

where

$$a = 0,67 + 0,38 \cdot \frac{s}{(h_{\text{nom}} - h_s)} \quad (2.2.3.2.7)$$

$$b = 0,33 - 0,38 \cdot \frac{s}{(h_{\text{nom}} - h_s)} \quad (2.2.3.2.8)$$

If steel failure occurs during the group test, the test results shall be converted from the tensile strength of the used samples to the specified tensile strength of the screws in accordance with clause A.2.1. The converted results shall be used for the assessment in this clause.

Expression of the results

Factor for resistance to concrete cone failure in cracked and uncracked concrete $k_{cr,N}$, $k_{ucr,N}$ [-].

Effective embedment depth h_{ef} [mm].

Characteristic edge distance to tension load $c_{cr,N}$ [mm].

2.2.4 Robustness

Purpose of the assessment

Assessment of the influence of reduced cleaning effort. This effect shall be assessed in test series F9, F10, H1 to H4. The final factor γ_{inst} shall be assessed in clause 2.2.4.7.

Assessment method

2.2.4.1 Robustness to variation in use conditions (test series F9)

EAD 330232-02-0601 [1], clause 2.2.4.1, applies. Reference of this test is the test line A3 of Table A.1.1.

2.2.4.2 Robustness to contact with reinforcement (test series F10)

EAD 330232-02-0601 [1], clause 2.2.4.2, applies. Reference of this test is the test line A3 of Table A.1.1.

2.2.4.3 Robustness in dry concrete, reduced cleaning (test series H1)

EAD 330499-02-0601 [2], clause 2.2.5.2, applies. The tests shall be carried out as unconfined tension tests. Reference of this test is the test line A1 of Table A.1.1.

2.2.4.4 Robustness to deeper drilling depth, reduced interaction with bonding material (test series H2)

These tests shall be performed to determine the sensitivity of the performance to foreseeable and unavoidable variations in the installation process, in particular with regards to the variation of drilling depth. The intent of this test line is to check whether the bonding material is mixed properly in the drill hole and that the amount of bonding material in the nominal embedment depth of the screw is sufficient to deliver the assessed performance.

The test requirements below are relevant for systems with a defined volume of bonding material or, in any case, with the mixing of the bonding material components occurring by means of the setting of the concrete screw, e.g., given amount of trigger pulls for injection in MPII.

For injection systems, if a bonding material volume is not given in MPII a suitable mean (e.g., stop drill bit) shall be used to avoid variation in the drilling depth during jobsite operations. This suitable mean shall be given in the intended use of the ETA.

For injection systems, if the bonding material volume given in the MPII is sufficient to cover the additional drilling depth in accordance with equation (2.2.4.4.1), then this test shall be omitted.

If the use of a suitable mean (e.g., stop drill bit) to avoid a foreseeable variation in the drilling depth during jobsite operations is enforced by the MPII, this test shall be omitted.

Test conditions

The tests shall be carried out as unconfined tension tests in uncracked concrete C20/25.

Based on the drilling depth recommendation given in the MPII, these tests shall be performed with a drilling depth increased by an additional drilling length as the maximum value between 10% of the given drilling depth h_1 and 10 mm.

$$h_{1,H2} = h_1 + \{\max(0,1 \cdot h_1; 10 \text{ mm})\} + \Delta h_1 \quad (2.2.4.4.1)$$

The term Δh_1 in the equation (2.2.4.4.1) represents a possible range of variation for the drilling depth h_1 given in the MPII, e.g., also considering the various combinations of actual fixture thicknesses t_{fix} (in the case of through setting). The value of Δh_1 shall be taken equal to 15 mm only if a defined drilling depth is not given in the MPII.

If cleaning of the drill hole before setting is not required by the MPII, the tests shall be performed in the most unfavourable conditions, i.e., with the drilling depth h_1 for the non-cleaned drill hole as given in the MPII, and considering the variation of the amount of dust in the drill hole.

Assessment

Failure loads

- Determine the mean value of failure loads $N_{u,m}$ [kN] converted to the nominal concrete strength.
- Determine the 5%-fractile of the failure loads $N_{u,5\%}$ [kN] converted to the nominal concrete strength.
- Verify the coefficient of variation of failure loads. If the coefficient of variation exceeds 20% ($cv_F > 20\%$), determine the reduction factor for large scatter β_{cv} in accordance with clause A.2.2.
- Determine the reduction factors α in accordance with Annex A. Test series A1 is used as corresponding reference test series.
- Determine the factor to account for the sensitivity to installation in accordance with Table 2.2.4.7.1. Depending on which level of rqd. α the factor α fulfils the corresponding value of γ_{inst} is taken.
- Compare the factor γ_{inst} with the result of the test series F9, F10, H1, H3, H4. The larger value governs.
- If $\alpha < 0,70$ use the reduction factor α together with rqd. $\alpha = 0,70$ in equation (2.2.2.15.1) and $\gamma_{\text{inst}} = 1,4$.

Load displacement behaviour:

- Verify the criteria for uncontrolled slip and determine the load N_{sl} [kN] in accordance with clause A.2.5.
- Determine the mean value of the failure loads $N_{u,m}$ [kN] of the test series.
- Determine the displacements at 50% of the mean failure load $\delta_{0,5N_{u,m}}$ [mm] in each test.
- Determine the coefficient of variation of the displacements at 50% of the mean failure load cv_δ [%]. If the displacements at 50% of the failure load are larger than 0,4 mm, cv_δ shall not exceed 40%.

2.2.4.5 Robustness in water saturated concrete, reduced cleaning (test series H3)

EAD 330499-02-0601 [2], clause 2.2.5.3, applies. The tests shall be carried out as unconfined tension tests. Reference of this test is the test line A1 of Table A.1.1.

2.2.4.6 Robustness in water filled holes (clean water), reduced cleaning (test series H4)

EAD 330499-02-0601 [2], clause 2.2.5.4, applies. The tests shall be carried out as unconfined tension tests. Reference of this test is the test line A1 of Table A.1.1.

2.2.4.7 Assessment of the factor for sensitivity to installation

The factor γ_{inst} accounting for the sensitivity to installation shall be evaluated from the test results of the tests for robustness, i.e., test series F9, F10, H1 to H4.

For each test series F9, F10, H1 to H4 the factor γ_{inst} shall be determined in accordance with Table 2.2.4.7.1 by comparing the factor α with the value of rqd. α for the specific test. The largest resulting factor γ_{inst} applies.

Table 2.2.4.7.1 Values of required α in the sensitivity to robustness tests

Factor γ_{inst}	reqd. α for tests in accordance with Table A.1.1		
	lines F9, H1, H2	lines F10	lines H3, H4
1,0	$\geq 0,95$	$\geq 0,85$	$\geq 0,90$
1,2	$\geq 0,80$	$\geq 0,70$	$\geq 0,75$
1,4	$\geq 0,70$	$\geq 0,60$	$\geq 0,65$

Expression of the results

Factor for robustness γ_{inst} [-].

2.2.5 Minimum edge distance and spacing, minimum concrete member thickness (test series F11)Purpose of the assessment and assessment method

EAD 330232-02-0601 [1], clause 2.2.5, for concrete screws applies.

Note: The installation steps for the two fasteners in the test series shall be done according to the MPII, e.g., in terms of working time and setting procedure.

Expression of the results

Minimum edge distance c_{min} [mm].

Minimum spacing s_{min} [mm].

Minimum concrete member thickness h_{min} [mm].

2.2.6 Characteristic resistance to concrete splitting under tension load, edge distance to prevent splitting under load (test series F12)Purpose of the assessment and assessment method

EAD 330232-02-0601 [1], clause 2.2.6, applies. Reference of this test is the test line A1 of Table A.1.1.

Expression of the results

Characteristic resistance to concrete splitting under tension load $N^{0}_{RK,sp}$ [kN],

Edge distance to prevent splitting under load $c_{cr,sp}$ [mm].

2.2.7 Resistance to steel failure under shear load, characteristic bending moment and ductility factor

2.2.7.1 Single fastener (test series V1)

Purpose of the assessment and assessment method

EAD 330232-02-0601 [1], clause 2.2.7.1, applies.

Tests shall be omitted if the performance assessed from testing on the concrete screw without bonding material is taken.

Expression of the results

Resistance to steel failure under shear load $V^{0}_{RK,s}$ [kN],

Characteristic bending moment $M^{0}_{RK,s}$ [Nm].

2.2.7.2 Group of fasteners and k_7 factor (test series V3)

Purpose of the assessment and Assessment method

EAD 330232-02-0601 [1], clause 2.2.7.2, applies.

The factor k_7 shall be determined by testing the concrete screw without bonding material.

Expression of the results

Ductility factor k_7 [-].

2.2.8 Resistance to tension load for seismic performance category C1

Purpose of the assessment and Assessment method

EAD 330232-02-0601 [1], clause 2.2.12, applies for the determination of the resistance to pull-out under seismic load category C1 for a single bonded screw anchor $N'_{Rk,p,C1}$.

The contribution of the bond material $N^0_{Rk,p,B,C1}$ of a single fastener to the overall performance of the bonded screw fastener shall be determined by equation (2.2.8.1). As default value, in case no tests for $N^0_{Rk,p,CS,C1}$ (without bond material) in accordance with EAD 330232-02-0601, clause 2.2.12, have been performed, $N^0_{Rk,p,B,C1} = N'_{Rk,p,C1}$ and $N^0_{Rk,p,CS,C1} = 0$ shall be considered.

$$N^0_{Rk,p,B,C1} = N'_{Rk,p,C1} - N^0_{Rk,p,CS,C1} \quad (2.2.8.1)$$

where

$N^0_{Rk,p,CS,C1}$ corresponds to the characteristic resistance to pull-out failure under seismic loading of the concrete screw without bond material $N_{Rk,p,C1}$ of a single anchor assessed in accordance with EAD 330232-02-0601, clause 2.2.12

$N'_{Rk,p,C1}$ characteristic resistance for pull-out under seismic loading of a single bonded screw

Expression of the results

Resistance to steel failure $N_{Rk,s,C1}$, [kN].

The contribution of the concrete screw to the combined pull-out and concrete failure under seismic load $N^0_{Rk,p,CS,C1}$ [kN].

The contribution of the bond material to the combined pull-out and concrete failure under seismic load $N^0_{Rk,p,B,C1}$ [kN] as determined by equation (2.2.8.1).

2.2.9 Resistance to tension load for seismic performance category C2, displacements

Purpose of the assessment and assessment method

EAD 330232-02-0601 [1], clause 2.2.14, applies for the determination of the resistance to pull-out under seismic load for a single bonded screw anchor $N'_{Rk,p,C2}$.

The contribution of the bond material $N^0_{Rk,p,B,C2}$ of a single fastener to the overall performance of the bonded screw fastener shall be determined by equation (2.2.9.1). As default value, in case no tests for $N^0_{Rk,p,CS,C2}$ without bond material in accordance with EAD 330232-02-0601, clause 2.2.14, have been performed, $N^0_{Rk,p,B,C2} = N'_{Rk,p,C2}$ and $N^0_{Rk,p,CS,C2} = 0$ shall be considered.

$$N^0_{Rk,p,B,C2} = N'_{Rk,p,C2} - N^0_{Rk,p,CS,C2} \quad (2.2.9.1)$$

where

$N_{Rk,p,CS,C2}^0$ corresponds to the characteristic resistance to pull-out failure under seismic loading of the concrete screw without bond material $N_{Rk,p,C2}$ of a single fastener assessed in accordance with EAD 330232-02-0601, clause 2.2.14

$N'_{Rk,p,C2}$ characteristic resistance for pull-out under seismic loading of a single bonded screw

Expression of the results

Resistance to steel failure $N_{Rk,s,C2}$, [kN].

The contribution of the concrete screw to the combined pull-out and concrete failure under seismic load $N_{Rk,p,CS,C2}^0$ [kN].

The contribution of the bond material to the combined pull-out and concrete failure under seismic load $N_{Rk,p,B,C2}^0$ [kN] as determined by equation (2.2.9.1).

Displacements $\delta_{N,C2}$ [mm], assessed in accordance with EAD 330232-02-0601, clause 2.2.14.

2.2.10 Resistance to shear load for seismic performance category C1

Purpose of the assessment and assessment method

EAD 330232-02-0601 [1], clause 2.2.13, applies.

Expression of the results

Resistance to steel failure $V_{Rk,s,C1}$, [kN].

2.2.11 Resistance to shear load for seismic performance category C2, displacements

Purpose of the assessment and Assessment method

EAD 330232-02-0601 [1], clause 2.2.15, applies.

Expression of the results

Resistance to steel failure $V_{Rk,s,C2}$ [kN].

Displacements $\delta_{V,C2}$ [mm].

2.2.12 Factor for annular gap

Purpose of the assessment and Assessment method

EAD 330232-02-0601 [1], clause 2.2.13, applies.

Expression of the results

Factor for annular gap α_{gap} [-].

2.2.13 Reaction to fire

The bonded screw fasteners are considered to satisfy the requirements of class A1 of the reaction-to-fire performance in accordance with the Commission Decision 96/603/EC, as amended by Commission Decisions 2000/605/EC and 2003/424/EC, without the need for testing on the basis of it fulfilling the conditions set out in that Decision and its intended use being covered by that Decision.

The bonding material is considered as a small component embedded in the concrete. In the end use of the application the reaction to fire class of the concrete is not influenced. Separate testing and classification are not necessary.

Therefore, the performance of the product is Class A1.

2.2.14 Fire resistance to steel failure (tension load)

Purpose of the assessment and assessment method

EAD 330232-02-0601 [1], clause 2.2.17, applies.

The tests shall be omitted if the concrete screw without bonding material has been already assessed with the criteria given in EAD 330232-02-0601 [1], clause 2.2.17, and it is demonstrated that the bonding material has no negative influence on the overall anchor performance under fire. In this case the performance of the concrete screw without bonding material shall be taken.

Note: This requirement may be achieved, e.g., with spot tests at given loads or laboratory testing on raw material.

Expression of the results

Fire resistance to steel failure (tension load) $N_{Rk,s,fi}$ [kN].

2.2.15 Fire resistance to pull-out failure (tension load)

For the fire resistance the bonding material contribution to the combined pull-out and concrete failure is negligible. Therefore, the assessment in the following considers only the pull-out failure of the concrete screw without bonding material).

Purpose of the assessment and assessment method

EAD 330232-02-0601 [1], clause 2.2.18, applies. Tests shall be performed with the concrete screw without bonding material.

In case that tests for concrete screws without bonding material are omitted and values are calculated based on EN 1992-4 [6], Annex D.4.2.3, only the pull-out resistance of the concrete screw without bonding material shall be taken for resistance of the bonded screw fastener.

Expression of the results

Fire resistance to pull-out failure (tension load) $N_{Rk,p,CS,fi}$ [kN].

2.2.16 Fire resistance to steel failure (shear load)

Purpose of the assessment and assessment method

EAD 330232-02-0601 [1], clause 2.2.19, applies.

Expression of the results

Fire resistance to steel failure (shear load) $V_{Rk,s,fi}$ [kN], $M^0_{Rk,s,fi}$ [Nm].

3 ASSESSMENT AND VERIFICATION OF CONSTANCY OF PERFORMANCE

3.1 System(s) of assessment and verification of constancy of performance to be applied

For the products covered by this EAD the applicable European legal act is Commission Decision 96/582/EC.

The system is 1.

3.2 Tasks of the manufacturer

The cornerstones of the actions to be undertaken by the manufacturer of the bonded screw fasteners in the procedure of assessment and verification of constancy of performance are laid down in Table 3.2.1.

Table 3.2.1 Control plan for the manufacturer; cornerstones

No	Subject/type of control	Test or control method	Criteria, if any	Minimum number of samples	Minimum frequency of control
Factory production control (FPC) [including testing of samples taken at the factory in accordance with a prescribed test plan]*					
Metal Parts **)					
1	Dimensions (outer diameter, inner diameter, thread length, etc.)	Calliper and/or gauge	Laid down in control plan	3	Every manufacturing batch or 100.000 elements or when raw material batch has been changed **)
2	Tensile Load or tensile strength *)	EN ISO 6892-1 [10], EN ISO 898-1 [11], EN ISO 3506-1 [12]		3	
3	Yield strength *)	EN ISO 6892-1 [10], EN ISO 898-1 [11], EN ISO 3506-1 [12]		3	
4	Core hardness and Surface hardness (at specified functioning relevant points of the product) – where relevant	Tests in accordance with EN ISO 6507-1 [13] or EN ISO 6508-1 [14]		3	
5	Roughness of cone - where relevant	profile method: EN ISO 12085 [15] Software measurement standards: EN ISO 5436-1 [16] calibration: EN ISO 12179 [17]		3	
6	Zinc plating - where relevant	x-ray measurement according EN ISO 3497 [18], magnetic method according EN ISO 2178 [19], Phase-sensitive eddy-current method according EN ISO 21968 [20]		3	
7	Fracture elongation - where relevant	EN ISO 6892-1 [10] EN ISO 898-1 [11]		3	
8	Hard metal tip of fastener made of stainless steel - where relevant	Check of material, geometry, position and fixing to stainless steel		3	
Bonding material					
1	Batch number and expiry date	visual check	Laid down in control plan	1	each batch
2	Components	check material and the mass of components according to the recipe			
3	Specific gravity / Density	Standardized method proposed by the manufacturer			
4	Viscosity				
5	Reactivity (gel time, where relevant: max. reaction temperature, time to max reaction temperature)				
6	Properties of raw material				(e.g., by infrared analysis)
7	Performance of the cured bonding material	(e.g., tension test to failure) ***		3	1 batch / year

*) Tests in accordance with this standard, however are, if necessary, performed on the finished product with the corresponding adaptations agreed with the TAB (e.g., geometrical aspects).

**) The lower control interval is decisive.

***) For injection bonding material that is part of a system assessed with an ETA according EAD 330499-02-0601 [2], this control may be replaced by confined tests with threaded rods. Otherwise, tests shall be done with the concrete screw, e.g., test line R1 of the present EAD.

3.3 Tasks of the notified body

The cornerstones of the actions to be undertaken by the notified body of the bonded screw fasteners in the procedure of assessment and verification of constancy of performance for the product are laid down in Table 3.3.1.

Table 3.3.1 Control plan for the notified body; cornerstones

No	Subject/type of control	Test or control method	Criteria, if any	Minimum number of samples	Minimum frequency of control
Initial inspection of the manufacturing plant and of factory production control					
1	The Notified Body will ascertain that the factory production control with the staff and equipment are suitable to ensure a continuous and orderly manufacturing of the bonding material and metal parts. In particular, it shall be checked if all tasks in Table 3.2.1. were performed.	Verification of the complete FPC as described in the control plan agreed between the TAB and the manufacturer	According to Control plan	According to Control plan	When starting the production or a new line
Continuous surveillance, assessment and evaluation of factory production control					
2	The Notified Body will ascertain that the system of factory production control and the specified manufacturing process are maintained taking account of the control plan.	Verification of the controls carried out by the manufacturer as described in the control plan agreed between the TAB and the manufacturer with reference to the raw materials, to the process and to the product as indicated in Table 3.2.1	According to Control plan	According to Control plan	1/year

4 REFERENCE DOCUMENTS

- | | | |
|------|---|--|
| [1] | EAD 330232-02-0601 | Mechanical fasteners for use in concrete |
| [2] | EAD 330499-02-0601 | Bonded fasteners for use in concrete |
| [3] | EAD 332795-00-0601 | Bonded screw fasteners for use in concrete |
| [4] | EAD 330011-00-0601 | Adjustable concrete screws |
| [5] | EN 206:2013+A2:2021 | Concrete - Specification, performance, production and conformity |
| [6] | EN 1992-4:2018 | Eurocode 2 - Design of concrete structures — Part 4: Design of fastenings for use in concrete |
| [7] | EOTA TR 075:2020-10 | Design of bonded screw fasteners for use in concrete |
| [8] | EN 1990:2023 | Eurocode - Basis of structural and geotechnical design |
| [9] | EN ISO 22479:2022 | Corrosion of metals and alloys - Sulfur dioxide test in a humid atmosphere (fixed gas method) (ISO 22479:2019) |
| [10] | EN ISO 6892-1:2019 | Metallic materials – Tensile testing – Part 1: Method of test at room temperature (ISO 6892-1:2019) |
| [11] | EN ISO 898-1:2013/
EN ISO 898-1:2013/AC:2013 | Mechanical properties of fasteners made of carbon steel and alloy steel - Part 1: Bolts, screws and studs with specified property classes – Coarse thread and fine pitch thread (ISO 898-1:2013+Cor1:2013) |
| [12] | EN ISO 3506-1:2020 | Fasteners - Mechanical properties of corrosion-resistant stainless steel fasteners - Part 1: Bolts, screws and studs with specified grades and property classes (ISO 3506-1:2020) |
| [13] | EN ISO 6507-1:2023 | Metallic materials – Vickers hardness test – Part 1: Test method (ISO 6507-1:2023) |
| [14] | EN ISO 6508-1:2023 | Metallic materials – Rockwell hardness test – Part 1: Test method (ISO 6508-1:2023) |
| [15] | EN ISO 12085:1997/
EN ISO 12085:1997/AC:2008 | Geometrical product specifications (GPS) - Surface texture: Profile method - Motif parameters (ISO 12085:1996+Cor1:1998) |
| [16] | ISO 5436-1:2000 | Geometrical Product Specifications (GPS) - Surface texture: Profile method; Measurement standards - Part 1: Material measures (ISO 5436-1:2000) |
| [17] | EN ISO 12179:2022 | Geometrical product specifications (GPS) - Surface texture: Profile method - Calibration of contact (stylus) instruments (ISO 12179:2021) |
| [18] | ISO 3497:2000 | Metallic coatings - Measurement of coating thickness - X-ray spectrometric methods (ISO 3497:2000) |
| [19] | ISO 2178:2016 | Non-magnetic coatings on magnetic substrates - Measurement of coating thickness - Magnetic method (ISO 2178:2016) |
| [20] | ISO 21968:2019 | Non-magnetic metallic coatings on metallic and non-metallic basis materials - Measurement of coating thickness - Phase-sensitive eddy-current method (ISO 21968:2019) |
| [21] | EN ISO/IEC 17025:2017 | General requirements for the competence of testing and calibration laboratories (ISO/IEC 17025:2017) |

ANNEX A TEST PROGRAMME AND GENERAL ASPECTS OF ASSESSMENT

A.1 Test programme

The test programme for the assessment consists of

- Basic tension tests and basic shear tests to assess basic values of characteristic resistance and
- Any other tests to assess the characteristic resistance regarding various effects for the relevant application range according to the intended use.

Table A.1.1 Test programme for concrete screws with bonding material

N°	Purpose of test	Concrete	Crack width	Size	d_{uct}	n_{min}	$r_{qd, \alpha}$	Test setup	Clause
Resistance to steel failure									
N1	Steel capacity	-	0	All	-	5	-	-	2.2.1.1
N3	Hydrogen embrittlement	C50/60	0	All	$d_{cut,med}$	5	0,90	Unconfined	2.2.1.2
Basic tension tests									
A1	Reference tension tests	C20/25	0	All	$d_{cut,med}$	5	-	Unconfined	2.2.2.1
A2	Reference tension tests	C50/60	0	All	$d_{cut,med}$	5	-	Unconfined	
A3	Reference tension tests	C20/25	0,30	All	$d_{cut,med}$	5	-	Unconfined	
A4	Reference tension tests	C50/60	0,30	All	$d_{cut,med}$	5	-	Unconfined	
A5	Group tests for effective embedment depth	a C20/25	0	All	$d_{cut,med}$	5	0,90	Unconfined	2.2.3.2
		b C50/60				5			
Resistance to combined pull-out and concrete failure									
F1	Maximum crack width and large hole diameter	C20/25	0,50	All	$d_{cut,max}$	5	0,80	Unconfined	2.2.2.2
F2	Maximum crack width and small hole diameter	C50/60	0,50	All	$d_{cut,min}$	5	0,80	Unconfined	2.2.2.3
F3	Crack cycling under load	C20/25	0,10-0,30	All	$d_{cut,med}$	5	0,90	Unconfined	2.2.2.4
F4	Repeated loads	C20/25	0	All	$d_{cut,med}$	5	1,00	Unconfined	2.2.2.5
F6	Torquing in low strength concrete	C20/25	0	All	$d_{cut,max}$	10	-	Unconfined	2.2.2.6
F7	Torquing in high strength concrete	C50/60	0	All	$d_{cut,min}$	10	-	Unconfined	2.2.2.6
F8	Impact screw driver	a C20/25	0	All	$d_{cut,max}$	15	-	Unconfined	2.2.2.6
		b C50/60			$d_{cut,min}$	15			
F9	Robustness to variation in use conditions	C20/25	0,30	All	1)	5	0,95 0,80 0,70	Unconfined	2.2.4.1
F10	Robustness to contact with reinforcement	C20/25	0,30	s/m	$d_{cut,med}$	5	0,85 0,70 0,60	Unconfined	2.2.4.2

N°	Purpose of test	Concrete	Crack width	Size	d _{uct}	n _{min}	rqd. α	Test setup	Clause
H1	Robustness in dry concrete with reduced cleaning	C20/25	0	All	d _{cut,med}	5	0,95 0,80 0,70	Unconfined	2.2.4.3
H2	Robustness to deeper drilling depth, reduced interaction with bonding material	C20/25	0	All	d _{cut,med}	5	0,95 0,80 0,70	Unconfined	2.2.4.4
H3	Robustness in water saturated concrete, reduced cleaning	C20/25	0	All	d _{cut,med}	5	0,90 0,75 0,65	Unconfined	2.2.4.5
H4	Robustness in water filled holes (clean water), reduced cleaning	C20/25	0	All	d _{cut,med}	5	0,90 0,75 0,65	Unconfined	2.2.4.6
F11	Minimum edge distance and spacing	C20/25	0	All	d _{cut,med}	5	-	Unconfined	2.2.5
F12	Edge distance to prevent splitting under load	C20/25	0	All	d _{cut,med}	4	1,0	Unconfined	2.2.6
Reference tests for bonding material sensitivities									
R1	Reference for increased and minimum temperature a) at normal ambient temperature	C20/25	0	3)	d _{cut,med}	5	-	Confined	2.2.2.8
R6	Reference for sustained load a) at normal ambient temperature and b) at maximum long-term temperature c) at minimum installation temperature < 0 °C	C20/25	0	3)	d _{cut,med}	5	-	Confined	2.2.2.10
R7	Reference for freeze/thaw	C50/60	0	3)	d _{cut,med}	5	-	Confined	2.2.2.11
R8	Reference for slice tests ²⁾	C20/25	0	3)	d _{cut,med}	5	-	Confined	2.2.2.13
Sensitivity tests for bonding material									
B2	Maximum long-term temperature	C20/25	0	3)	d _{cut,med}	5	-	Confined	2.2.2.7
B3	Maximum short-term temperature	C20/25	0	3)	d _{cut,med}	5	-	Confined	2.2.2.7
B4	Minimum installation temperature	C20/25	0	3)	d _{cut,med}	5	1,00	Confined	2.2.2.8
B5	Minimum curing time	C20/25	0	3)	d _{cut,med}	5+5	0,90	Unconfined	2.2.2.9
B14	Sustained loads (normal ambient temperature)	C20/25	0	3)	d _{cut,med}	5	0,90	Confined	2.2.2.10
B15	Sustained loads (maximum long-term temperature)	C20/25	0	3)	d _{cut,med}	5	0,90	Confined	2.2.2.10
B16	Freeze/thaw conditions	C50/60	0	3)	d _{cut,med}	5	0,90	Confined	2.2.2.11
B17	Installation direction	C20/25	0	3)	d _{cut,med}	5	0,90	Unconfined	2.2.2.12
B18	High alkalinity ²⁾	C20/25	0	3)	d _{cut,med}	10	1,00	Confined	2.2.2.13
B19	Sulphurous atmosphere ²⁾	C20/25	0	3)	d _{cut,med}	10	0,90	Confined	2.2.2.13
B20	Installation temperature below 0 °C	C20/25	0	3)	d _{cut,med}	5	-	Confined	2.2.2.14
Characteristic resistance to shear load									

N°	Purpose of test	Concrete	Crack width	Size	d_{uct}	n_{min}	rqd. α	Test setup	Clause
V1	Characteristic resistance to steel failure under shear load	C20/25	0	All	$d_{cut,med}$	5	-	-	2.2.7.1
V2	Characteristic resistance to pry-out failure	C20/25	0	All	$d_{cut,med}$	5	-	-	EAD 330232-02-0601 [1], 2.2.8
V3	Group of fasteners under shear loading	C20/25	0	All	$d_{cut,med}$	5	-	-	2.2.7.2

- 1) Test conditions are detailed in EAD 330232-02-0601 [1].
- 2) These tests shall be performed with threaded rods M12 (½”) only if the mixing of the bonding material is not affected by the use of threaded rods instead of concrete screws.
- 3) Tests with fastener size, which has the largest contribution $\Delta\alpha_{B,max}$ to overall performance in uncracked concrete given by the bonding material for all sizes and embedment depths (with $\Delta\alpha_{B,max}$ in accordance with equation (2.2.2.1.2)).

Table A.1.2 Test programme for concrete screw fasteners (without bonding material)

N°	Purpose of test	Concrete	Crack width	Size	d_{cut}	n_{min}	rqd. α	Test setup	Clause
Basic tension tests ¹⁾									
A1 (CS)	Reference tension tests	C20/25	0	All	$d_{cut,med}$	5	-	Unconfined	2.2.2.1
A2 (CS)	Reference tension tests	C50/60	0	All	$d_{cut,med}$	5	-	Unconfined	
A3 (CS)	Reference tension tests	C20/25	0,30	All	$d_{cut,med}$	5	-	Unconfined	
A4 (CS)	Reference tension tests	C50/60	0,30	All	$d_{cut,med}$	5	-	Unconfined	

- 1) These tests shall be performed and assessed in accordance with EAD 330232-02-0601 [1].

Provisions for all test series

As far as applicable EAD 330232-02-0601 [1], clause A.3 and A.4 shall be followed for the test members, test setup and performance of the tests. Modifications are addressed in the following clauses, which overrule conflicting provisions in EAD 330232-02-0601 [1], clause A.3 and A.4. The tension tests shall be performed with unconfined and confined test setup.

Handling of tests and calibration items are performed in accordance with EN ISO/IEC 17025 [20].

If the fasteners are intended to be installed with more than one embedment depth, the tests shall be carried out with all embedment depths.

In case that the manufacturer applies for the adjustability in the setting process, an assessment in accordance with the EAD 330011-00-0601 [4] shall be carried out. The potential influence on the performance of the adjusting process during the curing of the bonded material shall be considered. The tests shall be done with the most unfavourable setting condition (e.g., sequence of unscrewing and screwing steps at various curing stages according to the MPII. If no information is given in the MPII the complete spectrum of possibilities shall be assessed.

A.2 General assessment methods

A.2.1 Conversion of failure loads to nominal strength

The conversion of failure loads shall be done in accordance with equation (A.2.1.1) to (A.2.1.6) depending on the failure mode.

Concrete failure	$N_{u,c} = N_{u,t} \cdot \left(\frac{f_{ck}}{f_{c,t}}\right)^{0,5}$ with $\frac{f_{ck}}{f_{c,t}} \leq 1,0$	(A.2.1.1)
Pull-out failure	$N_{u,p} = N_{u,t} \cdot \left(\frac{f_{ck}}{f_{c,t}}\right)^m$ with $\frac{f_{ck}}{f_{c,t}} \leq 1,0$	(A.2.1.2)
	$m_{ucr} = \frac{\log\left(\frac{N_{u,m,A2}}{N_{u,m,A1}}\right)}{\log\left(\frac{f_{c,t,A2}}{f_{c,t,A1}}\right)} \leq 0,50$	(A.2.1.3)
	$m_{cr} = \frac{\log\left(\frac{N_{u,m,A4}}{N_{u,m,A3}}\right)}{\log\left(\frac{f_{c,t,A4}}{f_{c,t,A3}}\right)} \leq 0,50$	(A.2.1.4)
	$\psi_{c,xx} = \left(\frac{f_{ck,xx}}{f_{ck,20}}\right)^m$ ¹⁾	(A.2.1.5)
Steel failure	$N_{u,s} = N_{u,t} \cdot \frac{f_{uk}}{f_{u,t}}$ (for tension tests)	(A.2.1.6)
	$V_{u,s} = V_{u,t} \cdot \frac{f_{uk}}{f_{u,t}}$ (for shear tests)	

¹⁾ If no distinction is made for cracked and uncracked conditions, the factor m shall be determined as the minimum of equations (A.2.1.3) and (A.2.1.4).

A.2.2 Criteria regarding scatter of failure loads

If the coefficient of variation of the failure load in any basic test series exceeds 15% and is not larger than 30%, the following reduction shall be taken into account:

$$\beta_{cv} = \frac{1}{1 + 0,03(cv_F - 15)} \leq 1,0 \quad (\text{A.2.2.1})$$

If the coefficient of variation of the failure load in any other test series exceeds 20% and is not larger than 30%, the following reduction shall be taken into account:

$$\beta_{cv} = \frac{1}{1 + 0,03(cv_F - 20)} \leq 1,0 \quad (\text{A.2.2.2})$$

If the maximum limit for the coefficient of variation of the failure loads of 30% is exceeded the number of tests shall be increased to meet this limit. The present EAD does not cover fasteners for which this limit cannot be achieved.

If the coefficient of variation is smaller than the criteria mentioned above, $\beta_{cv} = 1,0$.

The smallest result of β_{cv} shall be taken for assessment.

A.2.3 Establishing 5 % fractile

The 5 %-fractile of the ultimate loads measured in a test series shall be calculated according to statistical procedures for a confidence level of 90 %. If a precise verification does not take place, a normal distribution and an unknown standard deviation of the population shall be assumed.

$$F_{u,5\%} = F_{u,m}(1 - k_s \cdot cv_F) \quad (\text{A.2.3.1})$$

$$F_{u,95\%} = F_{u,m}(1 + k_s \cdot cv_F) \quad (\text{A.2.3.2})$$

e.g.: n = 5 tests: $k_s = 3,40$

n = 10 tests: $k_s = 2,57$

Note: The confidence level of 90% is defined for characteristic resistance of fasteners in EN 1992-4 [6] 3.1.12 and is therefore used for the assessment in the present EAD.

A.2.4 Determination of reduction factors α

For all any other test series the mean failure loads and 5% - fractile of failure loads shall be compared with the corresponding reference test series of basic tension tests:

$$\alpha = \min \left\{ \frac{F_{u,m,t}}{F_{u,m,r}}, \frac{F_{u,5\%,t}}{F_{u,5\%,r}} \right\} \quad (\text{A.2.4.1})$$

If the number of tests in both series is $n \geq 10$, the comparison of the 5% - fractile of failure loads shall be done under assumption of a k-value of 1,645 for the determination of the factor α only.

The comparison of the 5%-fractile shall be omitted for any number of tests in a test series when the coefficient of variation of the test series is smaller than or equal to the coefficient of variation of the reference test series or if the coefficient of variation in both test series is smaller than 15%.

For tests for robustness to variation in use conditions and robustness to contact with reinforcement the reduction factor α shall be used to determine the factor $\gamma_{inst.}$

For all other test series with unconfined setup, the following references shall be used for the comparison in accordance with equation (A.2.4.1):

- $F_{u,m,r} = N_{Rk,c} / 0,75$
- $F_{u,5\%,r} = N_{Rk}$ (characteristic resistance).

A.2.5 Criteria for uncontrolled slip under tension loading

The load/displacement curves shall show a steady increase (see Figure A.2.5.1). A reduction in load and/or a horizontal part in the curve caused by uncontrolled slip of the fastener is not acceptable up to a load of:

$$\text{Tests in cracked concrete: } N_{sl} = 0,7 N_{Ru} \quad (\text{A.2.5.1})$$

$$\text{Tests in uncracked concrete } N_{sl} = 0,8 N_{Ru} \quad (\text{A.2.5.2})$$

Where the requirement given in equations (A.2.5.1) and (A.2.5.2) is not met in a test, meaning $N_{sl,t} < 0,7 N_{Ru,t}$ and $N_{sl,t} < 0,8 N_{Ru,t}$, respectively, the reduction factor α_1 shall be determined in accordance with equation (A.2.5.3).

$$\alpha_1 = N_{sl,t} / N_{Ru,t} \quad (\text{A.2.5.3})$$

Where

$N_{sl,t}$ = load level where uncontrolled slip occurs in the test

$N_{Ru,t}$ = ultimate load in the test

This reduction shall be omitted if, within an individual series of tests, not more than one test shows a load/displacement curve with a short plateau below the value determined by equation (A.2.5.1) (see Figure A.2.5.1, curve 3), provided all of the following conditions are met:

- the deviation is not substantial
- the deviation can be justified as uncharacteristic of the fastener behaviour and is due to a defect in the fastener tested, test procedure, etc.
- the fastener behaviour meets the criterion in an additional series of 10 tests.

The lowest value for $\alpha_1 / \text{rqd. } \alpha_1$, with $\text{rqd. } \alpha_1 = 0,7$ for tests in cracked concrete and $\text{rqd. } \alpha_1 = 0,8$ for tests in uncracked concrete, in all tests is inserted into equation (2.2.2.15.1).

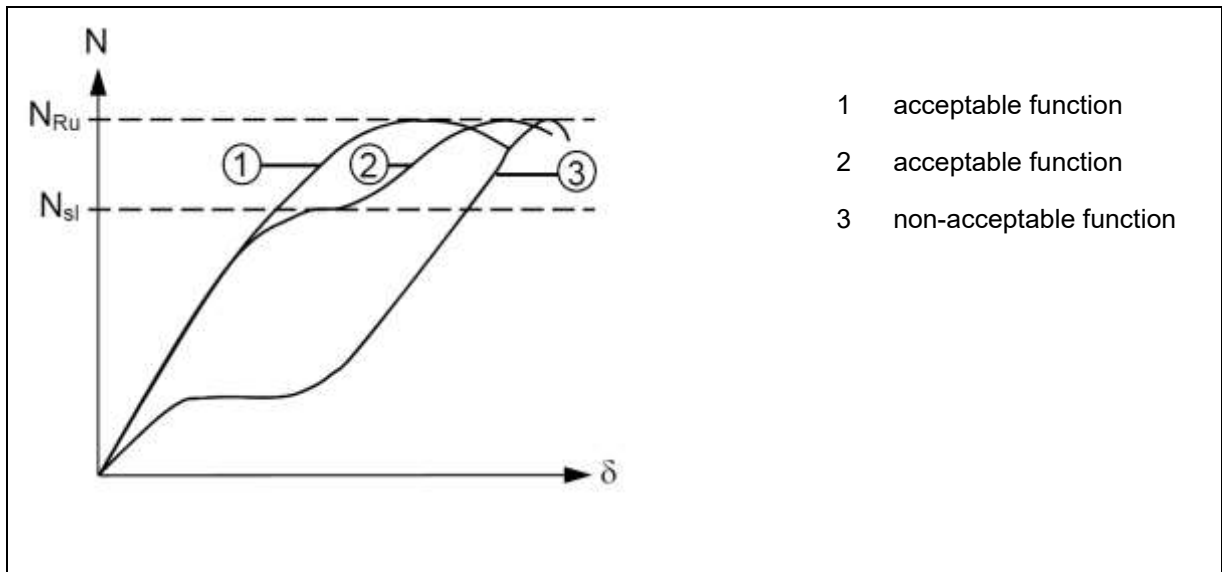

Figure A.2.5.1 Examples for load/displacement curves

Uncontrolled slip of the fastener occurs if the expansion sleeve or expansion elements are significantly moving in the drilled hole. This can be caused by failure of the highly loaded concrete in the region of the undercut. This slip can be recognized by a reduction in load and/or a horizontal or nearly horizontal part in the load/displacement curve with a corresponding displacement of > 0,5 mm.

The ultimate load is the maximum load recorded in the test independently of the displacement.

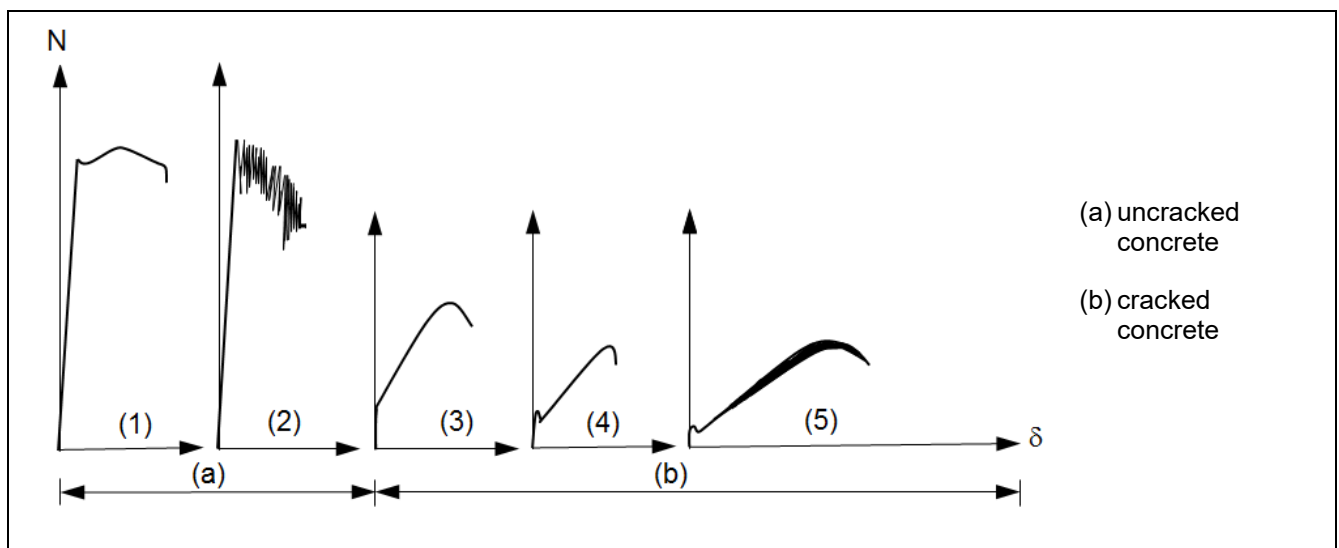

Figure A.2.5.2 Typical load/displacement behaviour

Uncontrolled slip of a fastener occurs under sliding friction conditions, when an increase of the load is only generated by inaccuracies of the drilled hole (e.g., change in diameter over its length, off centre over its length).

This can be recognized when the extension of the load/displacement curve is cutting the displacement axis at displacements $\delta \geq 0$ (see Figure A.2.5.3). The load N_{sl} is defined by the horizontal branch of the load/displacement curve.

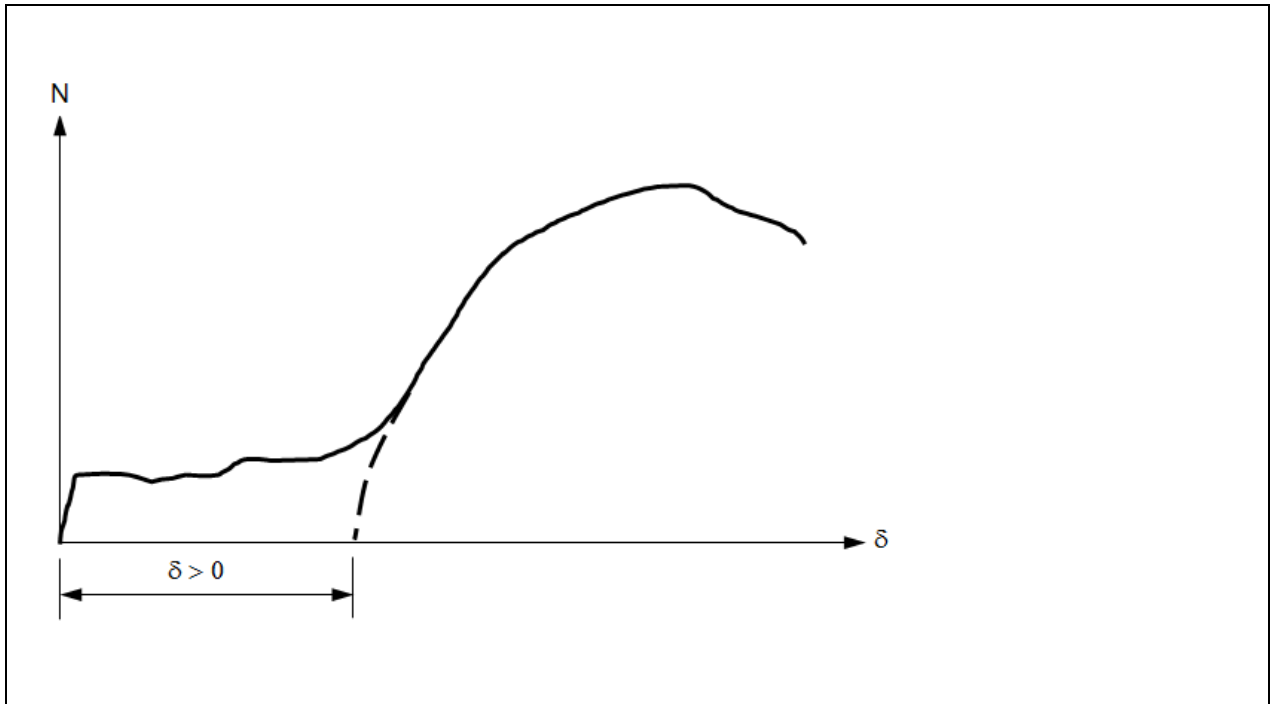

Figure A.2.5.3 Load/displacement behaviour with uncontrolled slip

Because it may be difficult to draw an extension to a curved line the following simplification may be used.

It is an indication of uncontrolled slip if the load/displacement curve falls below the linear connection between the peak load (ultimate load) and the zero point in any area (see Figure A.2.5.4).

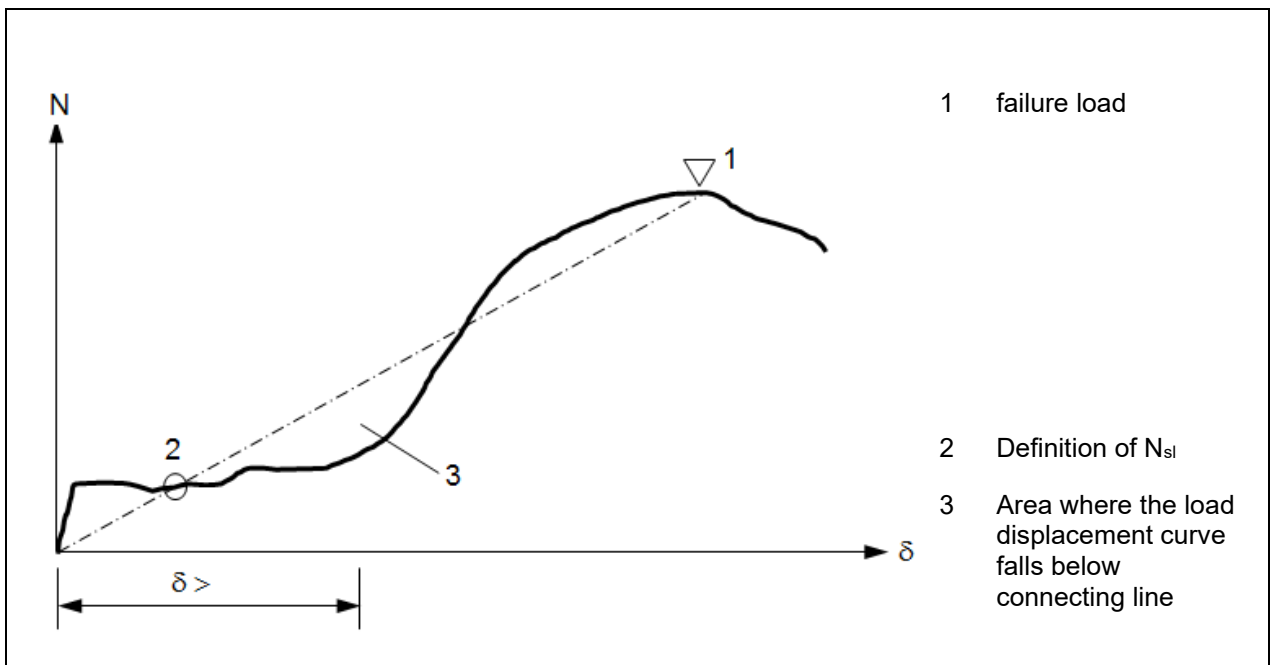

Figure A.2.5.4 Load/displacement behaviour with uncontrolled slip

The load N_{Sl} as given above shall be defined as the lower intersection point of the straight line with the load/displacement curve.

In comparing results of assessments in accordance with Figure A.2.5.3 and Figure A.2.5.4, the type given in Figure A.2.5.3 will govern.

A.2.6 Limitation of the scatter of displacements

In order to properly activate all fasteners of a fastener group, the displacement behaviour (stiffness) of individual fasteners shall be similar.

The coefficient of variation of the mean displacement at the load level of $0,5 N_{u,m}$ in basic tension tests shall fulfil the limit given in equation A.2.6.1 and for any other tests the limit given in equation (A.2.6.2) shall be kept.

$$cv_{\delta} \leq 0,25 \text{ (basic tension tests)} \quad (\text{A.2.6.1})$$

$$cv_{\delta} \leq 0,40 \text{ (any other tests)} \quad (\text{A.2.6.2})$$

The load displacement curves may be shifted according Figure A.2.6.1 for determination of the displacement at $0,5 N_{u,m}$.

It is not necessary to observe limitation of the scatter of the load/displacement curves in a test series if in this test series the mean value of displacement at a load of $0,5 N_{u,m}$ is smaller than or equal to $0,4 \text{ mm}$.

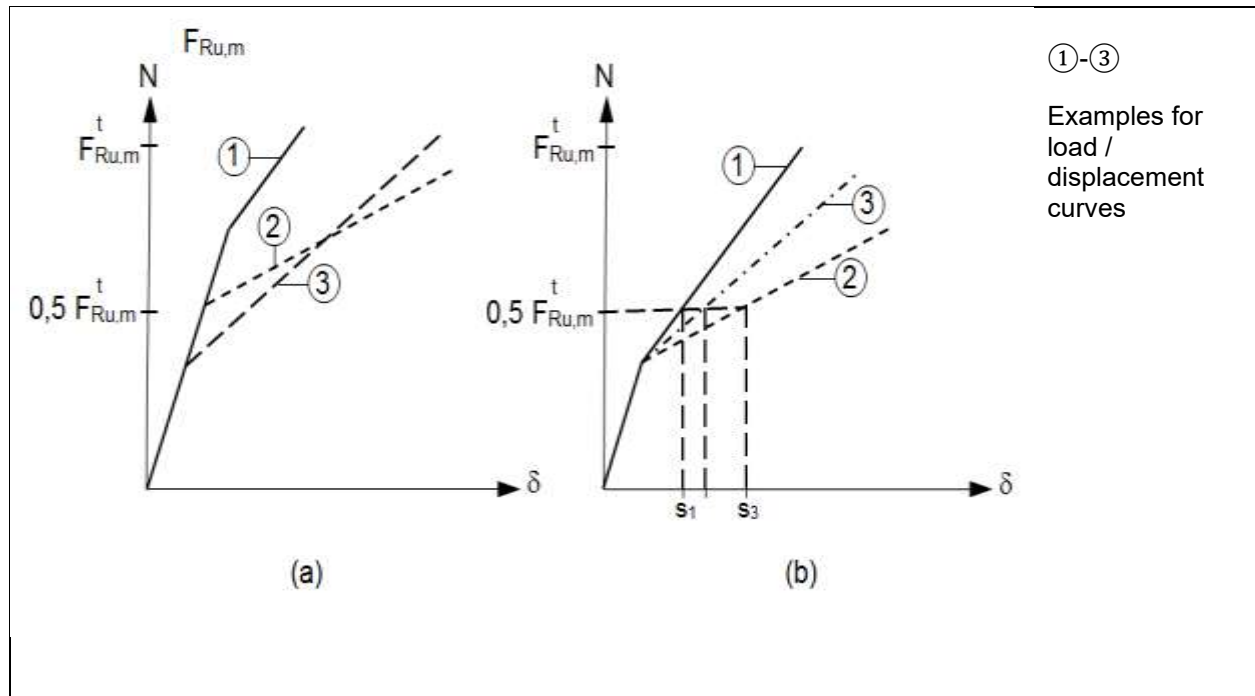

Figure A.2.6.1 Influence of pre-stressing on load/displacement curves

(a) original curves

(b) shifted curves for evaluation of scatter at $N = 0,5 N_{u,m}$