



European Organisation for Technical Approvals
Europäische Organisation für Technische Zulassungen
Organisation Européenne pour l'Agrément Technique

ETAG 020

Edition March 2006

amended version March 2012

GUIDELINE FOR EUROPEAN TECHNICAL APPROVAL

of

**PLASTIC ANCHORS FOR MULTIPLE USE
IN CONCRETE AND MASONRY
FOR NON-STRUCTURAL APPLICATIONS**

Annex A:

DETAILS OF TESTS

EOTA©

Kunstlaan 40 Avenue des Arts
B – 1040 Brussels

TABLE OF CONTENTS

ANNEX A: DETAILS OF TESTS

1. TEST SAMPLES	3
2. TEST MEMBERS	3
2.1. Concrete test member	3
2.1.1. Aggregates	3
2.1.2. Cement	3
2.1.3. Water/cement ratio and cement content	3
2.1.4. Concrete strength	4
2.1.5. Dimensions of test members	4
2.1.6. Casting and curing of test members and specimens	5
2.2. Test member for masonry material	6
2.2.1. General	6
2.2.2. Test member for solid masonry material	6
2.2.3. Test member for hollow or perforated bricks and hollow blocks	6
2.3. Test member for autoclaved aerated concrete	6
2.3.1. Requirements for test specimens	6
2.3.2. Definition of test specimens/samples	7
2.3.3. Material characteristics	7
3. ANCHOR INSTALLATION	8
4. TEST EQUIPMENT	9
5. TEST PROCEDURE	12
5.1. General	12
5.2. Tension Test	12
5.3. Temperature Test	13
5.4. Shear Test	14
5.5. Test for determining minimum spacing and edge distance	14
5.5.1. Screwed-in plastic anchors for use in normal weight concrete	14
5.5.2. Plastic anchors for use in other base materials	14
5.6. Tests under sustained loading	14
5.7. Tests under relaxation	15
5.8. Maximum torque moment	15
6. TEST REPORT	15

1. TEST SAMPLES

Samples shall be chosen to be representative of normal production as supplied by the manufacturer, including screws, nails and plastic sleeves.

Sometimes the tests are carried out with samples specially produced for the tests before issuing the ETA. If so, it shall be verified that the plastic anchors subsequently produced conform in all respects, particularly suitability and bearing behaviour, with the plastic anchors tested.

2. TEST MEMBERS

2.1. Concrete test member

The test members shall be made in accordance with EN 206-1 [5] and comply with the following:

2.1.1. Aggregates

Aggregates shall be of medium hardness and with a grading curve falling within the boundaries given in Figure 2.1. The maximum aggregate size shall be 16 mm or 20 mm. The aggregate density shall be between 2,0 and 3,0 t/m³ (see EN 206-1 [5] and ISO 6783 [7]).

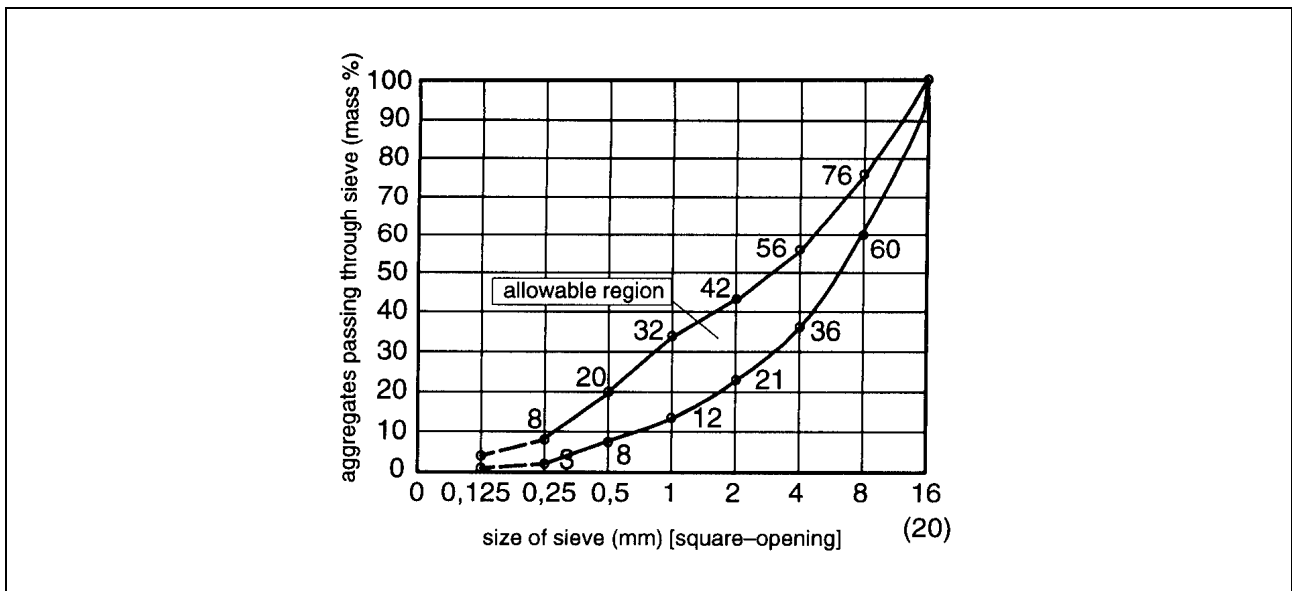

Figure 2.1: Admissible region for the grading curve

2.1.2. Cement

The concrete shall be produced using cement type CEM I, CEM II/A-LL or CEM II/B-LL (see EN 197-1 [6])

2.1.3. Water/cement ratio and cement content

The water/cement ratio shall not exceed 0,75 and the cement content shall be at least 240 kg/m³.

No additives likely to change the concrete properties (e.g. fly ash, or silica fume, limestone powder or other powders) shall be included in the mix.

2.1.4. Concrete strength

Tests are carried out in concrete strength class C20/25.

The following mean compressive strengths at the time of testing plastic anchors shall be obtained:

$$\begin{aligned} f_{cm} &= 20\text{-}30 \text{ MPa (cylinder: diameter 150 mm, height 300 mm)} \\ &= 25\text{-}35 \text{ MPa (cube: 150 x 150 x 150 mm)} \end{aligned}$$

It is recommended to measure the concrete compressive strength either on cylinders diameter 150 mm, height 300 mm, or cubes 150 mm.

If this is not done in certain cases, the concrete compressive strength may be converted thus:

$$\text{C20/25: } f_{cyl} = \frac{1}{1,25} \cdot f_{cube 150} \quad (2.1a)$$

Conversion factors for cubes of different sizes:

$$f_{cube 100} = \frac{1}{0,95} \cdot f_{cube 150} \quad (2.1b)$$

$$f_{cube 150} = \frac{1}{0,95} \cdot f_{cube 200} \quad (2.1c)$$

For every concreting operation, specimens (cylinder, cube) shall be prepared having the dimensions mentioned in this clause; the specimens being made and treated in the same way as the test members.

Generally, the concrete control specimens shall be tested on the same day as the plastic anchors in the corresponding concrete test member. If a test series takes a number of days, the specimens shall be tested at a time giving the best representation of the concrete strength at the time of the plastic anchor tests, e.g. in general at the beginning and at the end of the tests.

The concrete strength at a certain age shall be measured on at least 3 specimens, the mean value shall be used to check compliance with the requirement.

If, when evaluating the test results, there should be doubts whether the strength of the control specimens represents the concrete strength of the test members, then at least three cores of 100 mm or 150 mm diameter shall be taken from the test members outside the zones where the concrete has been damaged in the tests, and tested in compression. The cores shall be cut to a height equal to their diameter, and the surfaces to which the compression loads are applied shall be ground or capped. The compressive strength measured on these cores shall be converted into the strength of cubes by Equation (2.1d):

$$f_{c,cube 200} = 0,95 \cdot f_{c,cube 150} = f_{c,core 100} = f_{c,core 150} \quad (2.1d)$$

2.1.5. Dimensions of test members

The specification and dimensions of the test members shall conform to the following:

(a) Tests in cracked concrete

The tests are carried out on test members with unidirectional cracks; the crack width measured close to the anchor shall be approximately constant throughout the member thickness. The thickness of the test member should be $h \geq 2h_{nom}$ but at least 80 mm. The thickness of the test member has no effect on the minimum thickness given in the ETA. To control cracking, so-called 'crack-formers' may be built into the member, provided they are not situated near the anchorage zone. An example for a test member is given in Figure 2.2.

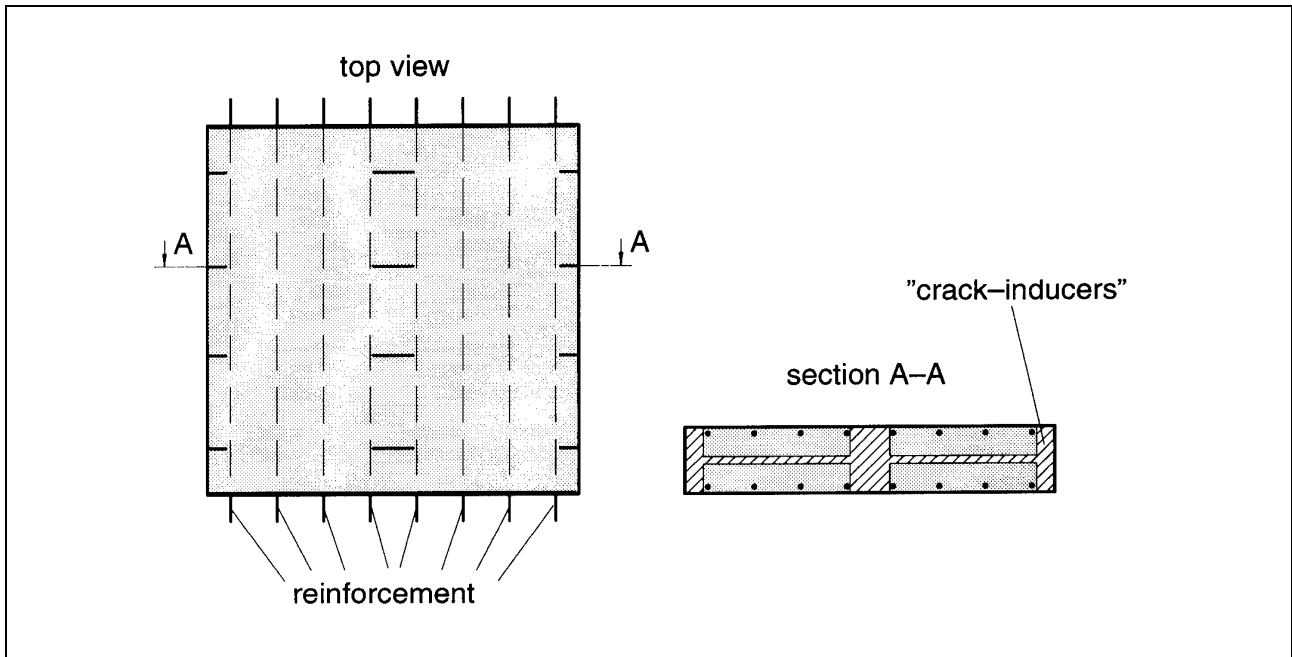

Figure 2.2: Example of a test member for plastic anchors tested in cracked concrete

When using a test member according to Figure 2.2, the reinforcement ratio and/or the member depth shall be sufficiently large to allow for a small increase in crack width during loading of the plastic anchor.

(b) Tests in non-cracked concrete

Generally, the tests are carried out on unreinforced test members. Only in the tests according to 5.5 the member may be provided with an edge reinforcement. This edge reinforcement used in the tests shall be stated in the ETA as a minimum requirement. The reinforcement bars shall be straight and have a concrete cover on both sides of 15 mm.

In cases where the test member contains reinforcement to allow handling or for the distribution of loads transmitted by the test equipment, the reinforcement shall be positioned such as to ensure that the loading capacity of the tested plastic anchors is not affected. This requirement will be met if the reinforcement is located outside the zone of concrete cones having a vertex angle of 120°.

In general, the thickness of the members shall correspond to the minimum member thickness applied by the manufacturer which will be given in the ETA (at least 80 mm).

For thin skins $40 \text{ mm} \leq h < 80 \text{ mm}$ (e.g. weather resistant skins of external wall panels according to ETAG 020, Part 1, 2.1.3.1.) follow ETAG 020, Part 2, 5.4.3. with Figure 5.1.

For precast prestressed hollow core slabs (according to ETAG 020, Part 1, 2.1.3.1.) see ETAG 020, Part 2, 5.4.3. with Figure 5.2.

2.1.6. Casting and curing of test members and specimens

In general, the test members shall be cast horizontally. They may also be cast vertically if the maximum height is 1,5 m and complete compaction is ensured.

Test members and concrete specimens (cylinders, cubes) shall be cured and stored indoors for seven days. Thereafter they may be stored outside provided they are protected such that frost, rain and direct sun does not cause a deterioration of the concrete compressive and tension strength. When testing the plastic anchors the concrete shall be at least 21 days old.

2.2. Test member for masonry material

2.2.1. General

The tests shall be performed in single units or in a wall. If tests are done in a wall, the thickness of the joints shall be about 10 mm and the joints shall be completely filled with mortar of strength class M2,5 with a strength $\leq 5 \text{ N/mm}^2$. If tests are performed with a mortar strength greater than M2,5 then the minimum mortar strength shall be given in the ETA. The walls may be lightly prestressed in vertical direction to allow handling and transportation of the wall.

2.2.2. Test member for solid masonry material

In general, bricks with a compressive strength between 20 and 40 N/mm^2 shall be used in the tests. Tests performed in solid masonry units made of lightweight concrete with compressive strength $f_{b,\text{test}}$ shall be converted to the nominal compressive strength f_b of the tested bricks or blocks using the following linear conversion rule: $N_{\text{RK1},0'} = N_{\text{RK1},0} \cdot (f_b / f_{b,\text{test}})$

All suitability tests and the tests according to Part 3, Table 5.2, line 1 shall be performed with single plastic anchors approximately in the centre of the unit under tension loading. The tension tests according to Part 3, Table 5.2, line 2 shall be performed at the free edge of a unit (tests in units) or the wall (tests in a wall) with an edge distance $c = c_{\text{min}}$.

The determined characteristic resistance given in the ETA is valid only for the unit sizes which are used in the tests or for larger sizes.

2.2.3. Test member for hollow or perforated bricks and hollow blocks

For details of test member see Part 4. The location of the plastic anchor with respect to the perforation shall be chosen such that the least plastic anchor resistance can be expected.

2.3. Test member for autoclaved aerated concrete

2.3.1. Requirements for test specimens

At the time of testing the autoclaved aerated concrete (AAC) test specimens shall meet the following conditions:

Low strength AAC		
mean dry density	ρ_m [kg/m^3]	≥ 350
mean compressive strength	$f_{c,m}$ [N/mm^2]	1,8 to 2,8
High strength AAC		
mean dry density	ρ_m [kg/m^3]	> 650
mean compressive strength	$f_{c,m}$ [N/mm^2]	6,5 to 8,0 (1)

- (1)** If the anchor manufacturer applies for autoclaved aerated concrete masonry units with $f_{c,m} > 8,0 \text{ N/mm}^2$ or reinforced components of autoclaved aerated concrete of strength $> \text{AAC 6}$ to be stated in the ETA, additional tests have to be performed for these compressive strengths.

2.3.2. Definition of test specimens/samples

Test specimens: Testing of plastic anchors is carried out on single units or walls with units glued together.

Samples: Samples (cubes/cylinders) are taken from the test specimen for determination of the material characteristics (see Figure 2.3).
(cube: 100 x 100 x 100 mm); (cylinder: diameter 100 mm, height 100 mm)

The sample for determination of the material characteristic shall be taken from the same height as the position of the anchor relating to the direction of rise of the aerated concrete specimen, because the strength differs depending on the height of the direction of rise.

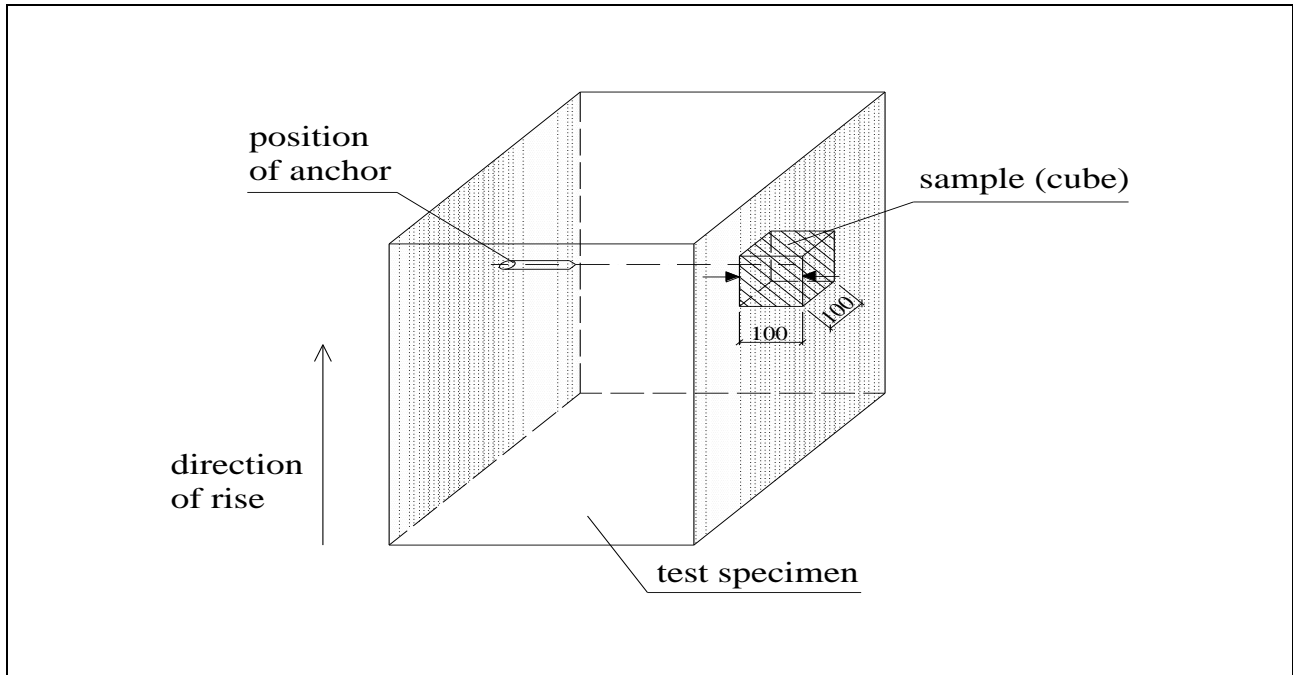

Figure 2.3: Taking of samples

2.3.3. Material characteristics

For determination of the material characteristics the following conditions apply:

Test specimens shall be taken from each batch (cycle of production) on delivery from the manufacturing plant and from each pallet on delivery from the retailer. Test specimens shall always be taken from series production. The direction of rise shall be discernible on the test specimen.

At the beginning of testing the test specimens shall be at least 4 weeks old. The moisture content of the concrete during the time of testing shall be ≤ 30 M% measured on the sample (cube/cylinder) or AAC block. The test specimens shall be stored in the testing laboratory or under comparable conditions such that air gains access on all sides. The clear distance between test specimens and from the floor shall be at least 50 mm.

Determination of the material characteristics (compressive strength, dry density) and moisture content is always carried out on the sample (cube/cylinder) or an AAC block. The characteristics shall be determined on at least 5 samples (cube/cylinder) or blocks. The compressive strength shall be determined as the mean value. Testing of the compressive strength is performed in the direction of plastic anchor setting (see Figure 2.3).

3. ANCHOR INSTALLATION

The plastic anchors shall be installed in accordance with the installation instruction supplied by the manufacturer.

In all tests screw-in-anchors shall be installed using a suitable screwgun. Nail-in-anchors shall be installed with a hammer having a reasonable hammer weight commonly used in the practical application.

For the installation safety tests special conditions are specified in the appropriate Part of this Guideline.

In case of concrete the tested plastic anchors shall be installed in the surface that has been cast against a form of the test member. Exception see section 5.5.

When testing in cracked concrete, plastic anchors are placed in the middle of hairline cracks. The main expansion direction of the plastic anchors shall be controlled in the tests. Details are specified in 5.1.

The holes for plastic anchors shall be perpendicular to the surface of the member.

In the tests the drilling tools and the type of drilling specified by the manufacturer shall be used. A drilling machine with a reasonable weight shall be used.

If hard metal hammer-drill bits are required, these bits shall meet the requirements of the standards DIN 8035 [13] or NF E 66-079 [14] with regard to dimensional accuracy, symmetry, symmetry of insert tip, height of tip and tolerance on concentricity.

The diameter of the cutting edges as a function of the nominal drill bit diameter is given in Figure 3.1.

In all tests for admissible service conditions the cylindrical hole is drilled with a medium diameter ($d_{cut,m}$) of the drill bit. For all tests checking suitability of the plastic anchor see Tables 5.1 in all Parts for the diameter of the drill bit.

The diameter of the drill bit shall be checked every 10 drilling operations to ensure continued compliance.

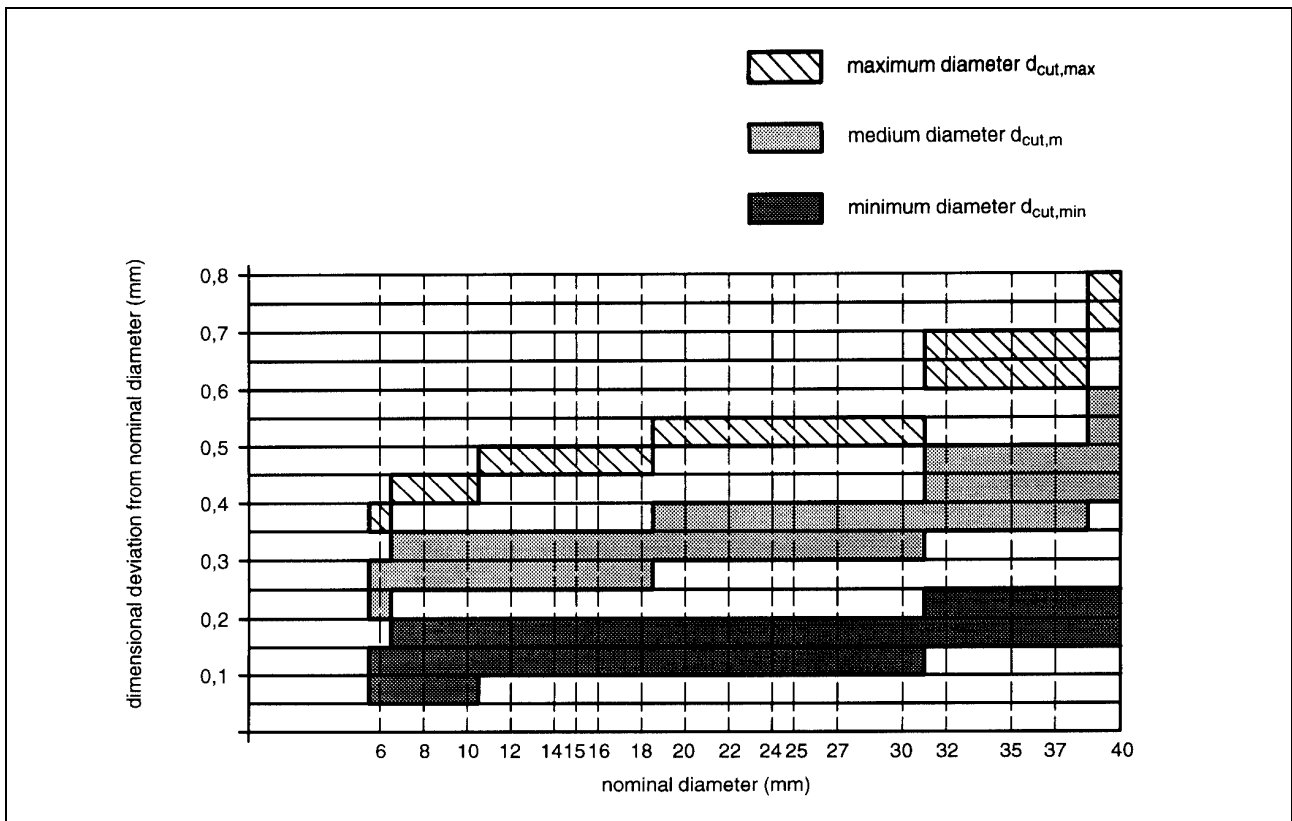

Figure 3.1: Cutting diameter of hard metal hammer-drill bits

4. TEST EQUIPMENT

The plastic anchor shall be installed with a special fixture (see Figure 4.1). The fixture shall guarantee the exact embedment depth of the plastic anchor. The fixture shall have the same form as the sleeve of the plastic anchor. All tests shall be performed with a diameter d_f of the clearance hole in the fixture as specified by the manufacturer e.g. external diameter of plastic anchors +0,5 mm.

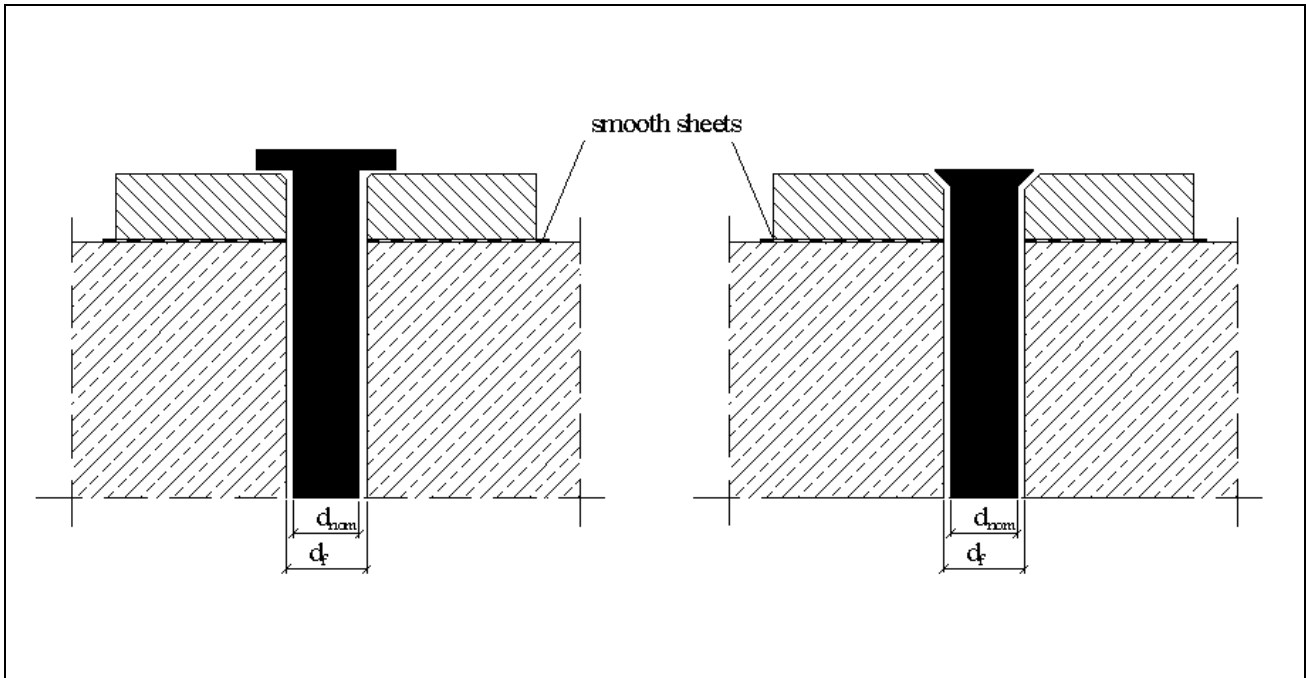

Figure 4.1 Special fixture for tension tests with plastic anchors

Tests shall be carried out using measuring equipment having calibration traceable. The load application equipment shall be designed to avoid sudden increase in load especially at the beginning of the test. The measuring error of the load shall not exceed 2 % throughout the whole measuring range.

Displacements shall be recorded continuously (e.g. by means of displacement electrical transducers) with a measuring error not greater than 0,02 mm.

In general, the test rigs shall allow the formation of an unrestricted rupture cone of the base material. For this reason the clear distance between the support reaction and a plastic anchor (single plastic anchor) shall be at least $2 h_{nom}$ (tension test) or $2 c_1$ (shear tests with edge influence). In shear tests without edge influence where steel failure is expected the clear distance may be less than $2 c_1$.

During tension tests (see 5.2), the load shall be applied concentrically to the plastic anchor. To achieve this, hinges shall be incorporated between the loading device and the plastic anchor. An example of the tension test rig is illustrated in Figure 4.2.

In shear tests (see 5.4), the load shall be applied parallel to the surface of the base material. In general the height of the fixture shall be equal to the outside diameter of the plastic anchor. To reduce friction, smooth sheets (e.g. PTFE) with a maximum thickness of 2 mm shall be placed between the fixture and the test member.

An example of a shear test rig is illustrated in Figure 4.3. As there is a lever arm between the applied load and the support reaction, this eccentricity moment shall be taken up by additional reaction forces placed sufficiently far away from the plastic anchor.

In torque tests the torque moment during installation and the torque moment at failure are measured. For this a calibrated torque moment transducer with a measuring error < 3 % throughout the whole measuring range shall be used.

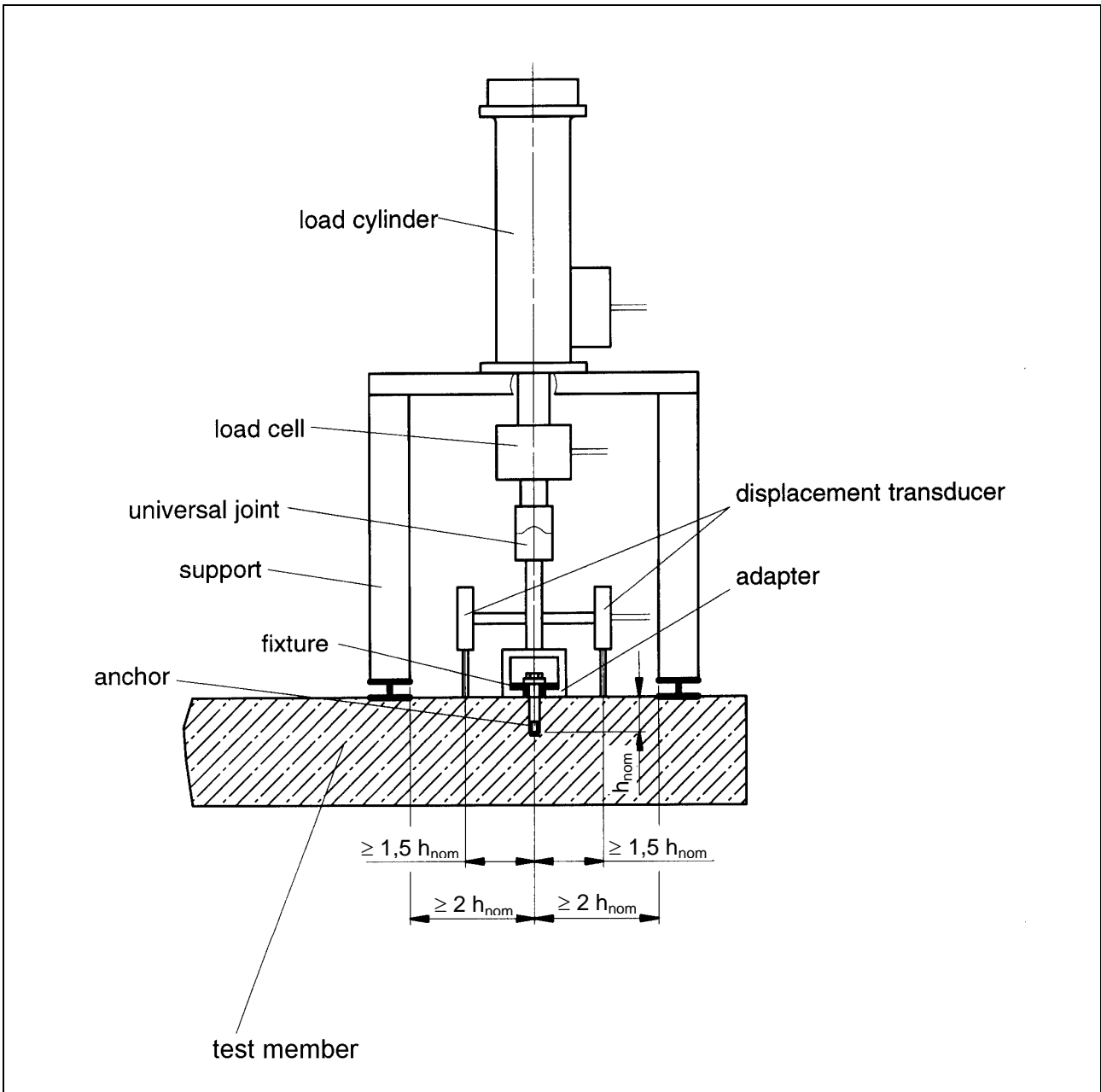

Figure 4.2 Example of a tension test rig

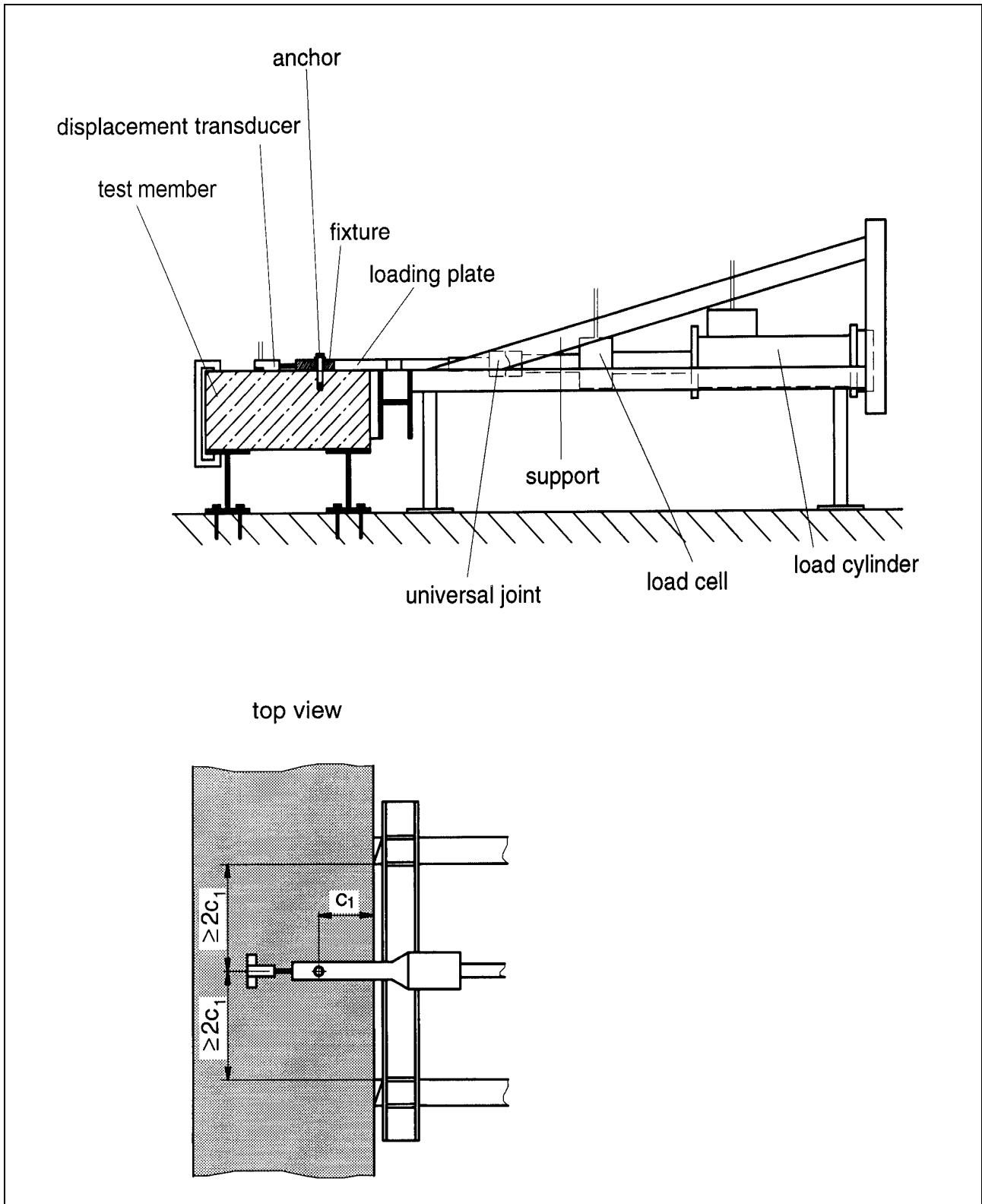

Figure 4.3 Example of a shear test rig

5. TEST PROCEDURE

5.1. General

The plastic anchors shall be installed in accordance with the installation instructions supplied by the manufacturer, except where deviations are specified in the corresponding Parts.

In general the tests are done with a standard conditioning of the plastic sleeve except in the suitability tests "Functioning under conditioning". For standard humidity the conditioning can be done according to ISO 1110 [16]. The dry conditioning can be reached by drying the plastic sleeve in an oven at +70 °C until the mass loss is smaller than 0,1 % in 3 consecutive measurements every 24 hours. The wet conditioning can be reached by placing the plastic sleeve under water until the mass increase is smaller than 0,1 % in 3 consecutive measurements every 24 h.

The tension tests in cracked concrete shall be done with the most unfavourable expansion direction with respect to the direction of the crack opening. The worst expansion direction shall be derived either from the plastic anchor design or by tests in cracked concrete.

The tests in cracked concrete are performed in unidirectional cracks. The plastic anchor has to be installed in closed hairline cracks. The crack width Δw is given in Part 2, Table 5.1 (suitability tests), Table 5.2 (tests for admissible service conditions) and in Part 5, Table 5.1 b and 5.2 b. Δw is the difference between the crack width when loading the plastic anchor and the crack width after installation. In general 5-10 min after the installation of the plastic anchor the crack is widened to the appropriate crack width while the plastic anchor is unloaded. The initial crack width at the start of loading the anchor shall be in a range in between ± 10 % of the specified value. However, the mean value of a series shall reflect the specified value.

The time difference between crack opening and loading of anchor has to be between 10 minutes and 3 days for all tests in cracked concrete. The suitability tests in cracked concrete according to Part 2, Table 5.1, line 3 and the corresponding reference tests in cracked concrete according to Part 2, Table 5.2, line 2 shall be performed approximately at the same time after crack opening, because the anchor resistance may increase with time after crack opening.

The crack width is controlled either:

- (a) At a constant width, for example, by means of a servo system or
- (b) Limited to a width close to the intended value by means of appropriate reinforcement and depth of the test member.

In both cases the crack width at the face opposite to that through which the plastic anchor is installed shall be maintained close to the specified value.

For tests in non-cracked concrete the anchor has to be loaded at least 10 minutes after installation except in the tests for relaxation. Suitability tests and corresponding reference tests shall be done approximately at the same time.

The load shall be increased in such a way that the peak load occurs after 1 to 3 minutes from commencement. Load and displacement shall be recorded either continuously or at least in about 100 intervals up to the peak load. The tests may be carried out with load or displacement control. In case of displacement control, then the test shall be continued up to at least 75 % of the maximum load to be measured (to allow the drop of the displacement curve) or at least up to 10 mm or $2 s_U$ displacement if the drop of the displacement curve is smaller than 75 %.

5.2. Tension Test

After installation, the plastic anchor is connected to the test rig and loaded to failure. The displacements of the plastic anchor relative to the surface of the test member at a distance of $\geq 1,5 h_{nom}$ from the plastic anchor shall be measured by use of either one displacement transducer on the head of the plastic anchor or at least two displacement transducers on either side; the mean value shall be recorded in the latter case.

When testing plastic anchors at the corner of a test member, then the test rig shall be placed such that an unrestricted failure towards the corner is possible (see Figure 5.1). It may be necessary to support the test rig outside the test member.

When testing in cracked concrete, the crack width shall be regularly measured during the test on both sides of the plastic anchor at a distance of approximately $1,0 h_{nom}$ and at least on the surface of the test member in which the plastic anchors are installed.

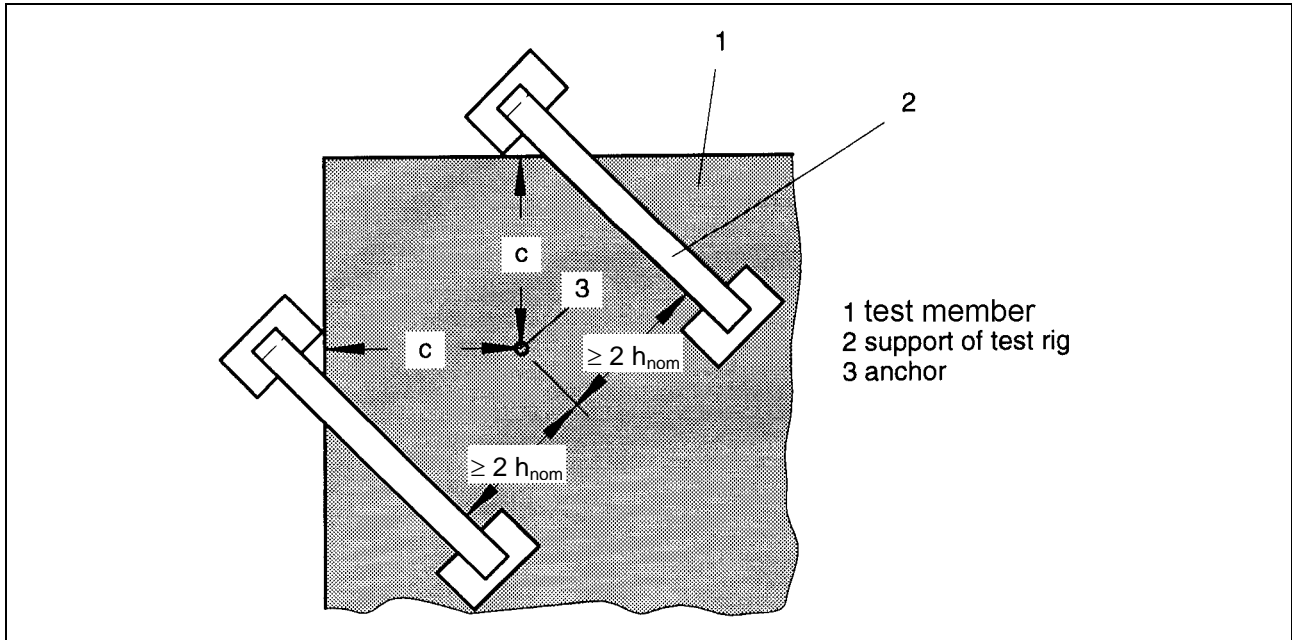

Figure 5.1 Example of the test rig for tension tests on plastic anchors at a corner

5.3. Temperature Test

The tests are carried out in slabs or, where space of the heating chamber is restricted, in cubes or in single masonry units. Splitting of the test member shall be prevented.

a) Tests at maximum long term temperature or maximum short term temperature:

Install plastic anchors at normal ambient temperature according to the manufacturer's installation instructions. Raise the test member temperature to the required maximum long term temperature or maximum short term temperature at a rate of approximately 20 K per hour. Cure the test member at this temperature for 24 hours. While maintaining the temperature of the test member in the area of the plastic anchor at a distance of $1d$ from the concrete surface at ± 2 K of the required value, carry out the tension test according to 5.2.

b) Tests at lowest service temperature min T:

After installation of the plastic anchors at normal ambient temperature raise the test member temperature to the maximum long term temperature and keep the test member at this temperature for 4 days. After that cool the test member to the lowest service temperature min T according to the specification of the manufacturer and carry out tension tests according to 5.2. Plastic anchors made out of polyamide have to be checked by pull-out tests only at the lowest service temperature, if this lowest service temperature specified by the manufacturer is less than -20 °C.

c) Tests at minimum installation temperature:

The plastic anchor shall be installed at the lowest installation temperature (plastic anchor and base material) specified by the manufacturer. After that cool the test member to the required minimum service temperature and carry out tension tests according to 5.2.

5.4. Shear Test

After installation, the plastic anchor is connected to the test rig without gap between the plastic anchor and the loading plate; it is then loaded to failure. The displacements of the plastic anchor relative to the base material shall be measured in the direction of the load application, for example by use of a displacement transducer fixed behind the plastic anchor (seen from the direction of load application) on the concrete (see Figure 4.2).

5.5. Test for determining minimum spacing and edge distance

5.5.1. Screwed-in plastic anchors for use in normal weight concrete

The tests are carried out with double plastic anchors with a spacing $s = s_{\min}$ and an edge distance $c = c_{\min}$. The double anchors are placed on an uncast side of a concrete test member with a distance $a \geq 3 h_{\text{nom}}$ between neighbouring groups. The dimensions of the fixture shall be width = $3 d_f$, length = $s_{\min} + 3 d_f$ and thickness $\cong d_f$.

The plastic anchors shall be installed according to the instructions of the manufacturer. Afterwards the anchors have to be torqued alternately in steps of about $0,2 T_{\text{inst},m}$ [$T_{\text{inst},m}$ determined in the "Maximum torque moment test" (e.g. Part 2, Table 5.1, line 8)]. After each load step the concrete surface shall be inspected for cracks. The test is stopped when the torque moment cannot be increased further.

The number of revolutions per load step may be measured for both plastic anchors. Furthermore, the torque moment at the formation of the first hairline crack at one or both plastic anchors and the maximum torque moment that can be applied to the two anchors shall be recorded.

For nailed-in plastic anchors for use in normal weight concrete Part 1, 5.4.2.2 is applied.

5.5.2. Plastic anchors for use in other base materials

Tension tests shall be performed at the free edge of a unit (tests in units) or the wall (test in a wall) with an edge distance $c = c_{\min}$.

5.6. Tests under sustained loading

The test is performed at normal temperature ($T = +21 \pm 3 \text{ }^\circ\text{C}$) for temperature range a), b) and c) and at maximum long term temperature for temperature range b) and c) [$T = +50 \text{ }^\circ\text{C}$ for temperature range b)].

The plastic anchor shall be installed at normal temperature.

The plastic anchor is then subjected to a load according to equation (5.3) which is kept constant (variation within $\pm 5 \%$).

For the tests at the maximum long term temperature [temperature range b) and c)] the test specimens, the loading equipment, the displacement transducers and the installed plastic anchors shall be heated to the maximum long term temperature at least for 24 hours before loading the plastic anchors.

The tests will generally be carried out over at least 3000 hours for plastic sleeves of PA6 or PA6.6 and 5000 hours for plastic sleeves of PE, PP or other polymeric materials.

$$N_p = 0,4 \cdot N_{R,k} \quad (5.3)$$

with:

$$N_{Rk} = \text{characteristic resistance of single anchor given in the ETA for the specific base material}$$

After completion of the sustained load test the plastic anchor shall be unloaded, the displacement measured and immediately after unloading a tension test performed.

5.7. Tests under relaxation

The plastic anchors are installed in the test member and left there unloaded for 24 hours and up to 500 hours. After that tension tests shall be carried out.

This test is not required for screwed-in plastic anchors with polyamide PA6 plastic sleeve, if failure is predominately caused by pulling out the sleeve and the screw together.

5.8. Maximum torque moment

The plastic anchor shall be installed with a screw driver or a spanner. The torque moment shall be measured with a calibrated torque moment transducer. The torque moment shall be increased until failure of the plastic anchor.

The torque moment is measured as a function of time. From the gradient of this curve two torque moments can be determined, the one if the screw is fully attached to the anchor collar (T_{inst}) and the maximum value (T_u) that can be applied to the plastic anchor.

6. TEST REPORT

As a minimum requirement, the report shall include at least the following information:

General

- Description and type of plastic anchor
- Anchor identification (dimensions, materials, coating, production method)
- Name and address of manufacturer
- Name and address of test laboratory
- Date of tests
- Name of person responsible for test
- Type of test (e.g. tension, shear, short-term or repeated load test)
- Number of tests
- Testing equipment: load cells, load cylinder, displacement transducer, software, hardware, data recording
- Test rigs, illustrated by sketches or photographs
- Particulars concerning support of test rig on the test member

Test members

- Composition of concrete. Properties of fresh concrete (consistency, density)
- Date of manufacture
- Dimensions of control specimens, and/or cores (if applicable) measured value of compressive strength, and in case of AAC moisture content, at the time of testing (individual results and mean value)
- Dimensions of test member
- Nature and positioning of any reinforcement
- Direction of concrete pouring

Anchor installation

- Information on the positioning of the plastic anchor
- Distances of plastic anchors from edges of test member and between adjacent anchors
- Tools employed for plastic anchor installation, e.g. impact drilling tool, drilling hammer, other equipment, e.g. torque wrench, hand hammer
- Type of drill bit, manufacturer's mark and measured drill bit dimensions, particularly the effective diameter, d_{cut} , of the hard metal insert
- Information on the direction of drilling
- Information on cleaning of the hole
- Depth of drill hole
- Width of crack when installing the plastic anchor (where applicable)
- Overall anchor embedment depth in the base material (h_{nom})
- Tightening torque or other parameters for control of installation
- Number of impacts for setting the nailed-in anchor
- Displacement of plastic anchor at the applied torque moment (if measured)
- Quality and type of screws and nuts employed
- Length of thread engagement (where applicable)
- Type of attachment

Measured values

- Parameters of load application (e.g. rate of increase of load or size of load increase steps)
- Displacements measured as a function of the applied load
- Any special observations concerning application of the load
- Width of crack during the loading of the plastic anchor
- Failure load
- Failure mode
- Radius (maximum radius, minimum radius) and height of a concrete cone produced in the test (where applicable)
- Particulars of repeated load tests
 - minimum and maximum load
 - frequency of cycles
 - number of cycles
 - displacements as function of the number of cycles
- Particulars of sustained load tests
 - constant load on plastic anchor and method of applying it
 - plastic anchor displacement as a function of time
- Particulars of torque test
 - maximum torque moment at installation
 - maximum torque moment at failure

The above measurements shall be recorded for each test.

- Particulars of identification tests
 - dimensions of the parts of the plastic anchor and the drilling- and installation tools
 - properties (e.g. tensile strength, elastic limit, elongation at rupture, if applicable)