

TR 054



Design methods for anchorages with metal injection anchors for use in masonry

April 2016
Amended April 2022
Amended July 2022
Amended December 2023
Amended March 2026

Contents

1	SCOPE OF THE TECHNICAL REPORT	4
1.1	General	4
1.2	Specifics for seismic design.....	4
1.3	Type of anchors, anchor groups and number of anchors	5
1.4	Base material.....	5
1.5	Type and direction of load	5
1.6	Specific terms used in this TR.....	5
2	BASIS OF DESIGN	10
2.1	Design concept	10
2.2	Ultimate limit state	10
2.3	Serviceability limit state	10
3	STATIC ANALYSIS	11
3.1	Loads acting on anchors.....	11
3.2	Shear loads with or without lever arm	11
4	VERIFICATION ULTIMATE LIMIT STATE (STATIC AND QUASI-STATIC ACTIONS).....	14
4.1	General.....	14
4.2	Resistance to tension loads	14
4.2.1	Required proofs	14
4.2.2	Failure of the metal part.....	14
4.2.3	Pull-out failure of the anchor	14
4.2.4	Brick breakout failure	14
4.2.5	Brick pull-out and combined failure	15
4.2.6	Influence of joints.....	16
4.3	Resistance to shear loads.....	16
4.3.1	Required proofs	16
4.3.2	Failure of the metal part, shear load without lever arm.....	17
4.3.3	Failure of the metal part, shear load with lever arm.....	17
4.3.4	Local brick failure.....	17
4.3.5	Brick edge failure	17
4.3.6	Pushing out of one brick	18
4.3.7	Influence of joints.....	18
4.4	Resistance to combined tension and shear loads	18
4.5	Additional provisions for prefabricated reinforced components made of autoclaved aerated concrete	19
5	VERIFICATION FOR FIRE RESISTANCE.....	20
5.1	General.....	20
5.2	Resistance to tension loads	20
5.2.1	Required proofs	20

5.2.2	Resistance to steel failure.....	20
5.2.3	Pull-out failure.....	20
5.2.4	Brick break out failure.....	20
5.2.5	Pull-out of one brick.....	21
5.2.6	Influence of joints.....	21
5.3	Resistance to shear loads.....	21
5.3.1	Required proofs.....	21
5.3.2	Failure of the metal part, shear load without lever arm.....	21
5.3.3	Failure of the metal part, shear load with lever arm.....	21
5.3.4	Local brick failure.....	22
5.3.5	Pushing out of one brick.....	22
5.3.6	Influence of joints.....	22
5.4	Resistance to combined tension and shear loads.....	22
6	VERIFICATION FOR INJECTION ANCHORS UNDER SEISMIC ACTIONS.....	23
6.1	General.....	23
6.2	Design and safety concept.....	23
6.2.1	Ultimate limit state.....	23
6.2.2	Damage limitation state.....	23
6.3	Requirements.....	23
6.4	Design options.....	23
6.5	Design criteria.....	24
6.6	Derivation of forces action on anchors.....	24
6.6.1	General.....	24
6.6.2	Addition to EN 1998-1 [5], 4.3.3.5.....	24
6.6.3	Addition to EN 1998-1 [5], 4.3.5.1.....	24
6.6.4	Addition and alterations to EN 1998-1 [5], 4.3.5.2.....	25
6.6.5	Addition to EN 1998-1 [5], 4.3.5.4.....	26
6.7	Resistance to tension and shear loads and combined tension and shear loads.....	26
6.7.1	Required verifications for tension and shear loading.....	26
6.7.2	Interaction - Resistance to combined tension and shear loads.....	28
6.8	Displacements.....	28
7	VERIFICATION FOR SERVICEABILITY LIMIT STATE.....	29
7.1	Displacements.....	29
7.2	Shear load with changing sign.....	29
8	REFERENCE DOCUMENTS.....	30

1 SCOPE OF THE TECHNICAL REPORT

1.1 General

The design rules in this Technical Report (TR) are only valid for anchors with a European Technical Assessment (ETA) on basis of EAD 330076-00-0604 [1] or EAD 330076-01-0604 [6] or EAD 330076-01-0604-v01 [9] or on basis of EAD 330460-00-0604 [7]. This document relies on characteristic resistances and distances which are stated in the ETA and referred to in this TR.

The proof of local transmission of the anchor loads into the masonry units is delivered by using the design methods described in this document. Proof of transmission of anchor loads to the supports of the masonry members shall be done by the engineer of the construction works.

1.2 Specifics for seismic design

In masonry structures subjected to earthquake ground motions, cracking is expected to be widespread and to be more severe in critical regions, such as e.g., in the diagonals of shear walls. The provisions of this Technical Report are based on the consideration that a crack width of 0,5 mm represents the mean crack width for regions on the masonry structure, excluding the critically damaged zones where cracks larger than 0,5 mm are expected.

A precondition for seismic anchor design is, therefore, a seismic design of the masonry members where anchors will be installed, including the potential identification of the critical regions mentioned above. The results of these design procedures are strongly depending on the assumptions used for the design of a building and shall be performed by an engineer experienced in anchorages and masonry work under seismic actions or under their supervision.

Only multiple anchorages shall be allowed, and single anchor installations shall be avoided by increasing the number of anchors per fixture to enable load redistribution to neighbouring anchors in case of excessive slip or premature failure of one anchor.

The definition of multiple anchor systems in the context of this Technical Report is given in terms of the number n_1 of fixing points to fasten the fixture and the number n_2 of anchors per fixing point (compare Figure 7.1). Furthermore, the load transfer in the case of excessive slip of one anchor needs to be considered in the design of the fixture.

The redistribution of loads in case of excessive slip or premature failure of one anchor shall be considered for the verification of the fastening.

$$n_1 \geq 1 \text{ and } n_2 \geq 2 \quad \text{or} \quad (1.1)$$

$$n_1 \geq 3 \text{ and } n_2 \geq 1 \quad (1.2)$$

with: n_1 = number of fixing points to fasten the element (structural or non-structural)
 n_2 = number of anchors per fixing point

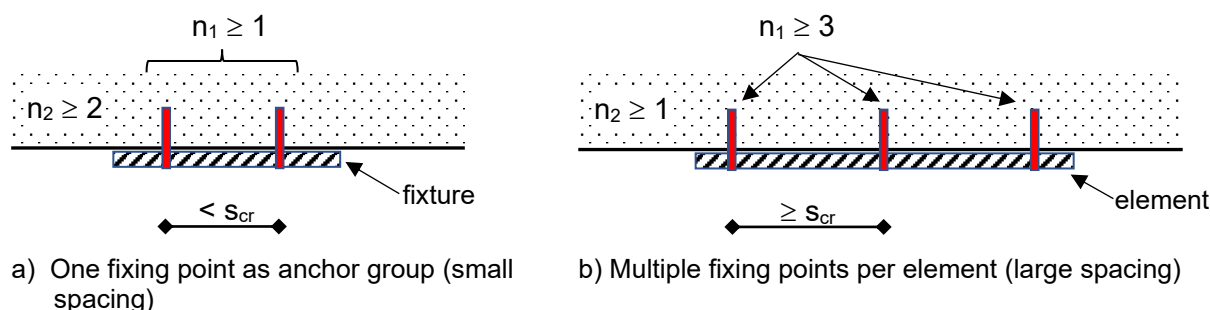

Figure 1.1: Examples of multiple injection anchor systems

1.3 Type of anchors, anchor groups and number of anchors

The essential characteristics of the specific anchor type (characteristic resistance values, edge distances, spacing and group factors) are given in the relevant ETA.

The design method is valid for single anchors and anchor groups with two or four anchors. In an anchor group only anchors of the same type, size and length shall be used.

1.4 Base material

The design method applies to the design of injection and screw anchors in masonry units of clay, calcium silicate, normal weight concrete, light weight concrete, autoclaved aerated concrete (AAC) or other similar materials.

In case of seismic actions and design according to section 6 of this TR only solid bricks as defined in EAD 330076-01-0604-v01 [9], clause 1.2.1, are covered.

The design and construction of masonry structures in which the injection and screw anchors are to be anchored shall be comparable with the structural rules for masonry, such as EN 1996 1-1:2005 + A1:2012 Clause 3 and 8 [6] and the relevant national regulations.

The detailed information of the corresponding base material is given in the ETA.

Base materials are defined as follows:

- masonry material (clay, calcium silicate, normal weight concrete, lightweight aggregate concrete, autoclaved aerated concrete or other similar materials),
- the specific masonry units including size of units, geometry of holes, webs and shells,
- for masonry units: mean gross dry density and normalised mean compressive strength of the masonry unit and mean compressive strength,
- for joints unfilled with mortar: joint width,
- for joints filled with mortar: mortar class, joint width,
- consideration of plaster or similar materials,
- setting position (wall side or reveal, distance to joints).

1.5 Type and direction of load

This Technical Report applies only to anchors subject to static or quasi-static actions or seismic in tension, shear or combined tension and shear and to anchors subject to static or quasi-static actions in bending.

Anchors featuring an ETA issued according to EAD 330076-00-0604 [1] or EAD 330076-01-0604 [6] for static and quasi-static action shall be designed according to the provisions in section 4 of this TR. They may also be used in areas with very low seismicity as defined in EN 1998-1, Clause 3.2.1 [5].

Anchors featuring an ETA according to EAD 330076-01-0604-v01 [8] for seismic actions shall be used in areas with seismicity higher than very low as defined in EN 1998-1 [5]. They shall be designed according to section 6 of this TR.

This Technical report covers applications only where the masonry members in which the anchors are embedded are subject to static, quasi-static or seismic actions.

1.6 Specific terms used in this TR

Definitions and abbreviations

Anchor	= a manufactured, assembled component (in case of injection anchors including bonding materials) for achieving anchorage between the base material (masonry) and the fixture
Anchor group	= several anchors (working together)
Fixture	= component to be fixed to the masonry
Anchorage, fastening	= an assembly comprising base material (masonry), anchor or anchor group and component fixed to the masonry

non-structural element	= architectural, mechanical or electrical element, system or component which, whether due to lack of strength or the way it is connected to the structure, is not considered in the seismic design of the structure as load carrying element; the failure of such an element may result in medium consequence for loss of human life and considerable economic, social or environmental consequences, but does not result in the failure of the structure or part of the structure; examples: façade element, piping, etc.
structural element	= Building element, the failure of which may result in the failure of the structure or part of the structure; examples: column, wall, arch, etc.
DLS	= Damage Limitation State (see EN 1998-1 [5], 2.2.1)
ULS	= Ultimate Limit State (see EN 1998-1 [5], 2.2.1)

Indices

E	= action
M	= material
N	= tension
R	= resistance
V	= shear
b	= brick breakout
c	= edge
d	= design value
eq	= seismic (earthquake)
fi	= fire
k	= characteristic value
j	= joint
m	= masonry
p	= anchor pull-out or pushing out
pb	= brick pull-out
pl	= plastic
s	= steel
u	= ultimate
y	= yielding

Superscripts

g	= load on or resistance of a group of anchors
h	= most loaded anchor of a group

Anchors

The notations and symbols frequently used in this TR are given below. Further particular notation and symbols are given in the text.

b_{brick}	= breadth of the brick
c	= edge distance towards the free edge of the brick
c_{cr}	= edge distance for ensuring the transmission of the characteristic resistance of a single injection anchor /screw anchor
c_{min}	= minimum edge distance to the free edge of the wall
c_j	= edge distance to joints without influence on resistance of the screw
$c_{j }$	= distance to vertical joints without influence on resistance of the screw
$c_{j\perp}$	= distance to horizontal joints without influence on resistance of the screw
$c_{j,fi}$	= edge distance to joints without influence on resistance of the screw in case of fire exposure

d	=	anchor bolt/thread diameter
d_f	=	diameter of clearance hole in the fixture
d_{nom}	=	outside diameter of anchor
h	=	thickness of masonry member (wall)
h_{min}	=	minimum thickness of masonry member
h_{ef}	=	effective anchorage depth
h_{nom}	=	overall anchor embedment depth in the masonry
h_{brick}	=	h_{unit} = height of the brick
l_{brick}	=	l_{unit} = length of the brick
s	=	spacing of the injection anchor / screw anchor
s_{cr}	=	spacing for ensuring the transmission of the characteristic resistance of a single injection anchor / screw anchor
$s_{cr,II}$	=	s_{cr} parallel to the horizontal joint
$s_{cr,\perp}$	=	s_{cr} perpendicular to the horizontal joint
s_{min}	=	minimum allowable spacing
$s_{min,II}$	=	minimum spacing parallel to the horizontal joint
$s_{min,\perp}$	=	minimum spacing perpendicular to the horizontal joint
t_{fix}	=	thickness of fixture
w_j	=	maximum width of joints (for $c < c_j$)

Base materials (masonry) and metal parts of anchor

f_b	=	normalised mean compressive strength of masonry
f_{mean}	=	mean compressive strength of masonry (intended use) according to EN 772-1 [4]
f_{yk}	=	nominal characteristic steel yield strength
f_{uk}	=	nominal characteristic steel ultimate strength

Loads / Forces / Resistances

A_a	=	seismic amplification factor
E_d	=	design action
F	=	force in general
N	=	normal force (+N = tension force)
V	=	shear force
M	=	moment
M_{pl}	=	plastic moment (yield mechanism)
R_d	=	design resistance
R_k	=	characteristic resistance
N_{Rk}, V_{Rk}	=	characteristic anchor resistance of a single anchor under tension or shear force
N_{Rk}^g, V_{Rk}^g	=	characteristic anchor resistance of an anchor group under tension or shear force
N_{Ed}^g, V_{Ed}^g	=	design value of actions acting on an anchor group
N_{Ed}^h, V_{Ed}^h	=	design value of actions acting on the highest loaded anchor
$\alpha_{g,N}$	=	group factor under tension load
$\alpha_{g,VI}$	=	group factor for screw groups under shear load parallel to the edge
$\alpha_{g,V\perp}$	=	group factor for screw groups under shear load perpendicular to the edge
$\alpha_{j,N}$	=	reduction factor for resistance under tension loading for-screws influenced by joints
$\alpha_{j,VI}$	=	reduction factor for resistance under shear loading parallel to the vertical joint for-screws influenced by joints
$\alpha_{j,V\perp}$	=	reduction factor for resistance under shear loading perpendicular to the vertical joint for screws influenced by joints

γ_M = partial factor for material

Displacements

$d (d_N, d_V)$ = displacement (movement) of the anchor at the masonry surface relative to the masonry surface in direction of the load (tension, shear) outside the failure area. The displacement includes the steel and masonry deformations and a possible anchor slip.

d_0 = displacement of the anchor under short-term loading

d_∞ = displacement of the anchor under long term loading

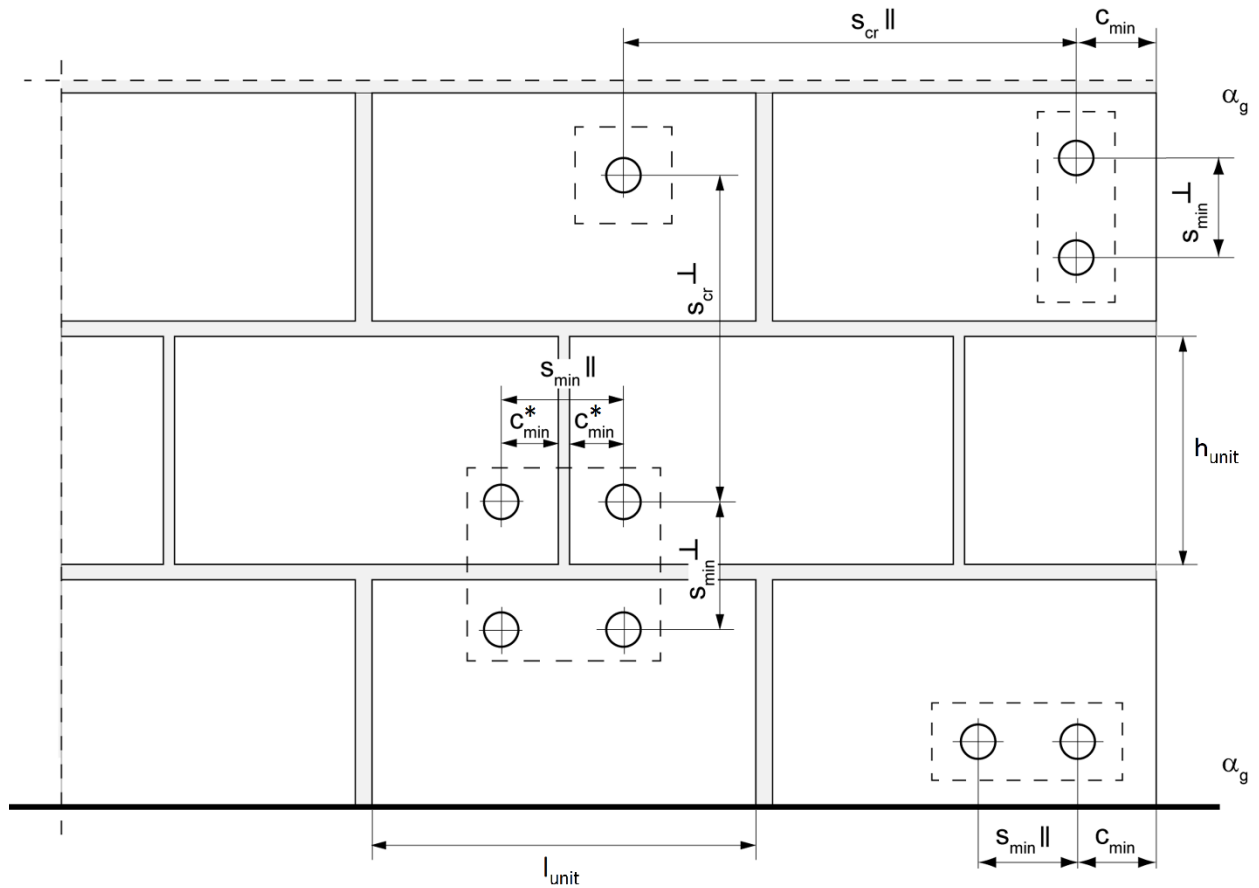

C_{min}^* = minimum edge distance, only if vertical joints are not filled with mortar

Figure 1.2: Edge distances, spacing for injection anchors

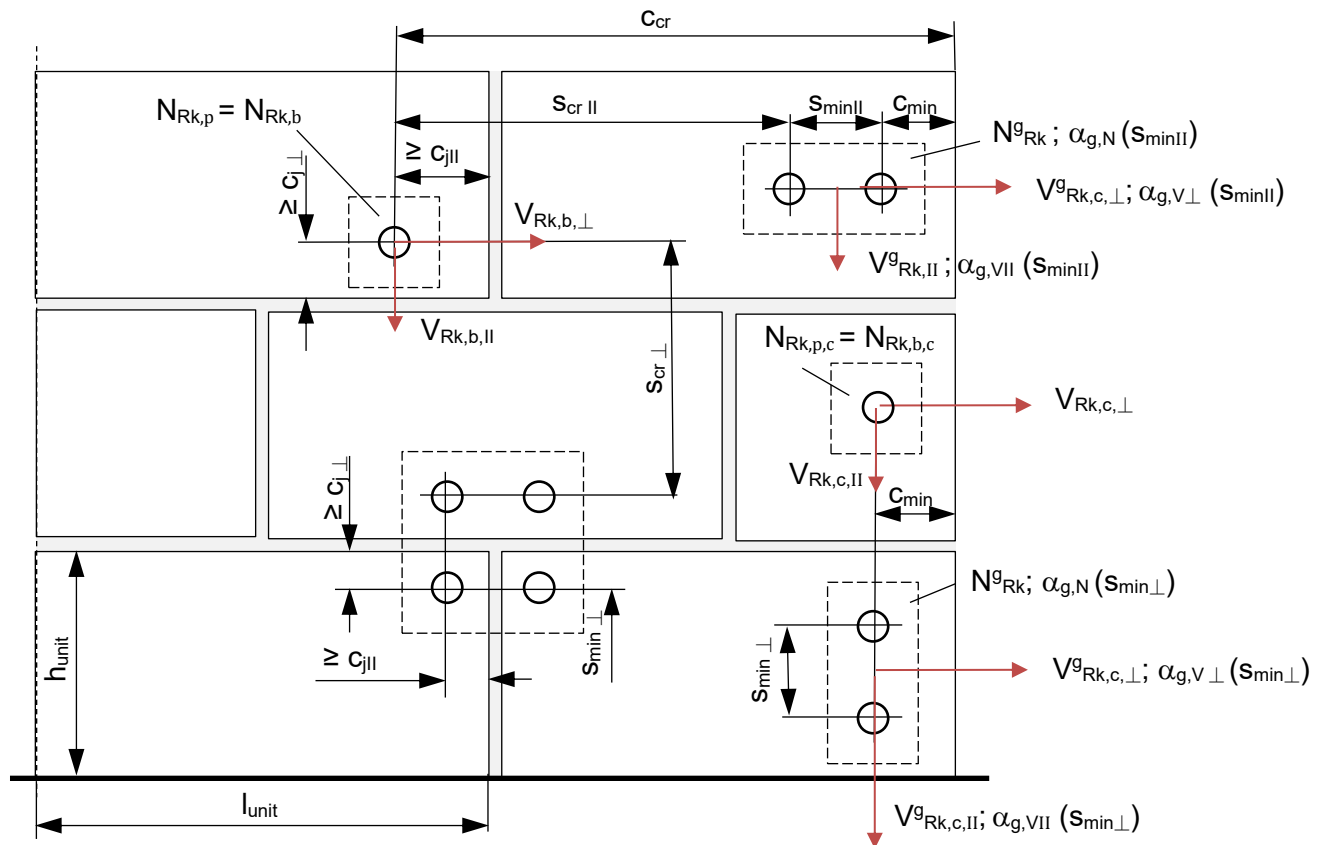

Figure 1.3: Edge distances, joint distances, spacing and resistances for screw anchors

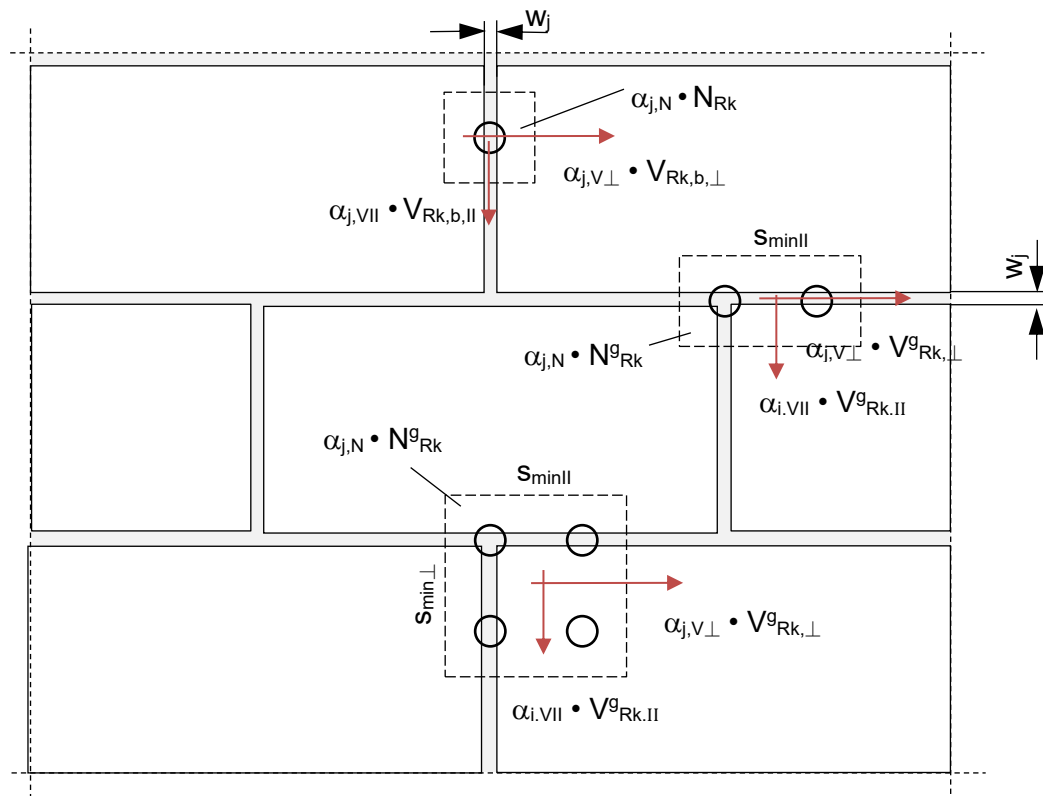

Figure 1.4: Reduction factors for resistances of screws in or near joints

2 BASIS OF DESIGN

2.1 Design concept

The design of anchorages shall be in accordance with the general rules given in EN 1990 [2]. It shall be shown that the value of the design actions E_d does not exceed the value of the design resistance R_d .

$$E_d \leq R_d \quad (2.1)$$

with: E_d = design value of action
 R_d = design value of resistance

Actions to be used in design may be obtained from national regulations or in the absence of them from the relevant parts of EN 1991 [3].

The partial factors for actions may be taken from national regulations or in the absence of them according to EN 1990 [2]. The design resistance is calculated as follows:

$$R_d = R_k / \gamma_M \quad (2.2)$$

with: R_k = characteristic resistance of a single anchor or an anchor group
 γ_M = partial factor for material

2.2 Ultimate limit state

The design resistance is calculated according to Equation (2.2).

In absence of national regulations, the following partial factors may be used:

Failure (rupture) of the metal part

Tension loading:

$$\gamma_{Ms} = \frac{1,2}{f_{yk}/f_{uk}} \geq 1,4 \quad (2.3)$$

Shear loading of the anchor with and without lever arm:

$$\begin{aligned} \gamma_{Ms} &= \frac{1,0}{f_{yk}/f_{uk}} \geq 1,25 & f_{uk} \leq 800 \text{ N/mm}^2 \text{ and } f_{yk}/f_{uk} \leq 0,8 \\ \gamma_{Ms} &= 1,5 & f_{uk} > 800 \text{ N/mm}^2 \text{ or } f_{yk}/f_{uk} > 0,8 \end{aligned} \quad (2.4)$$

Failure of the injection anchor or screw anchor

For use in masonry: $\gamma_{Mm} = 2,5$

For use in autoclaved aerated concrete: $\gamma_{MAAC} = 2,0$

Failure under fire exposure

For all materials and all failure modes: $\gamma_{M,fi} = 1,0$

2.3 Serviceability limit state

In serviceability limit state under static and quasi-static actions, it shall be shown that the displacements occurring under the characteristic actions (see chapter 7) are not larger than the permissible displacements. The permissible displacements depend on the application in question and shall be evaluated by the designer.

In this check the partial factors on actions and on resistances may be assumed to be equal 1,0.

3 STATIC ANALYSIS

3.1 Loads acting on anchors

Distribution of loads acting on anchors shall be calculated according to the theory of elasticity under the assumption of a rigid fixture. For further details concerning design tension on each anchor see EN 1992-4, 6.2.1 [11].

For steel failure under tension and shear and for pull-out failure under tension the load acting on the highest loaded anchor shall be determined.

In case of brick edge failure, the shear load is assumed to act on the anchor(s) closest to the edge.

3.2 Shear loads with or without lever arm

Shear loads acting on an anchor may be assumed to act without lever arm if all of the following conditions are fulfilled:

1. The fixture shall be made of metal and in the area of the anchorage be fixed directly to the base material without an intermediate layer or with a levelling layer of mortar with a compressive strength $\geq 30 \text{ N/mm}^2$ and a thickness $\leq d/2$.
2. The fixture is in contact with the anchor over a length of at least $0,5 t_{fix}$.
3. The diameter d_f of the hole in the fixture is not greater than the values d_f given in Table 3.1.

Table 3.1: Diameter of clearance hole in the fixture

Outside anchor bolt or thread diameter d or d_{nom} (mm)	6	8	10	12	14	16	18	20	22	24	30
Diameter of clearance hole in the fixture d_f (mm)	7	9	12	14	16	18	20	22	24	26	33

If these conditions are not fulfilled the bending moment acting on the anchor and the lever arm is calculated according to following Equation.

$$M_{Ed} = V_{Ed} \cdot \frac{l}{\alpha_M} \quad (3.1)$$

with: V_{Ed} = shear load acting on the anchor

l = length of the lever arm (see also Figure 3.1)

$$l = a_3 + e_1$$

e_1 = distance between shear load and surface of the member

$$a_3 = 0,5 \cdot d$$

= 0 if a washer and a nut are directly clamped to the masonry surface

d = diameter of the anchor bolt or thread diameter

α_M = depends on the degree of restraint of the anchor at the side of the fixture of the application in question and shall be judged according to good engineering practice

$\alpha_M = 1,0$ No restraint is assumed if the fixture can rotate freely (see Figure 3.2a). This assumption is always conservative. For fixtures made of timber no restrained shall be assumed.

$\alpha_M = 2,0$ Full restraint may be assumed only if the fixture cannot rotate (see Figure 3.2b) and the hole clearance in the fixture is smaller than the values given in Table 3.1 or the anchor is clamped to the fixture by nut and washer (see Figure 3.1). If restraint of the anchor is assumed the fixture shall be able to take up the restraint moment.

Note: Equation (3.1) gives only information on the acting bending moment in principle. The verification is done with V_{Ed} and $V_{Rd,s,M}$ (see Equation (4.6)).

If the conditions above are not fulfilled the increased shear load acting on the base material (caused by the shear load with lever arm under static and quasi-static actions) is calculated according to following Equation. The equation applies to solid bricks and hollow or perforated blocks with an embedment depth of the anchor/screw in at least two shells. For anchorages in only one shell, shear load with lever arm is excluded.

$$V_{Ed,h} = \frac{e_1+z}{z-a_3} \cdot V_{Ed} \tag{3.2}$$

with: V_{Ed}, e_1, a_3 see Equation (3.1) and Figure 3.3

$z = h_{ef} \leq 5 \cdot d_{nom}$ for solid bricks, hollow calcium silicate bricks with a minimum thickness of the outer shall of $5 \cdot d_{nom}$ and hollow bricks with more than 2 shells over the embedment depth

$= a_{shell}$ = distance of shells for hollow bricks with 2 shells over the embedment depth, the maximum distance between V_{Ed} and $V_{Ed,h}$ (see also to Figure 3.3) must not exceed the distance of shells

h_{ef} = effective embedment depth

d_{nom} = outside diameter of the anchor

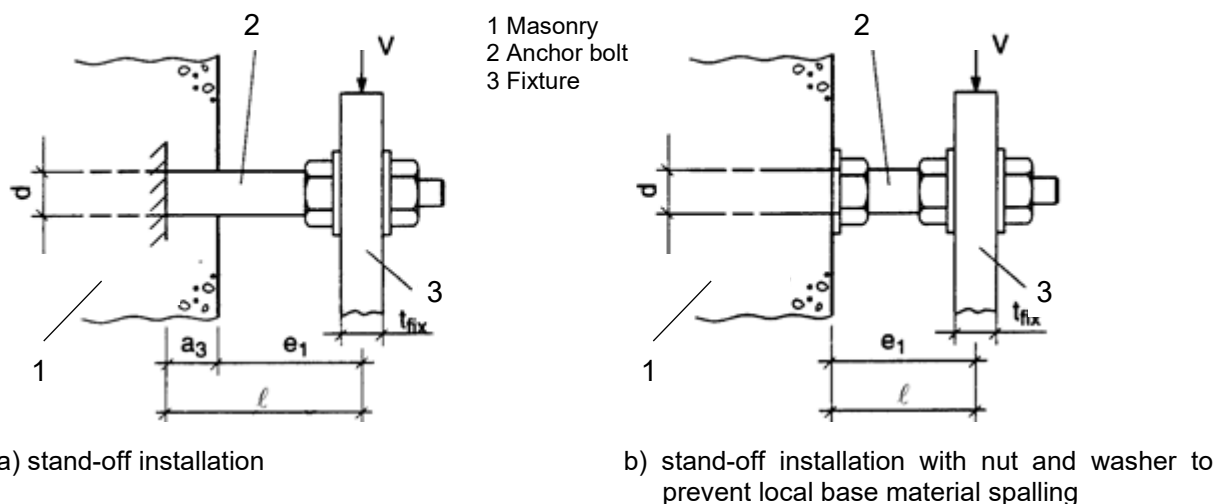

Figure 3.1: Definition of lever arm



Figure 3.2: Fixture without (a) and with (b) restraint

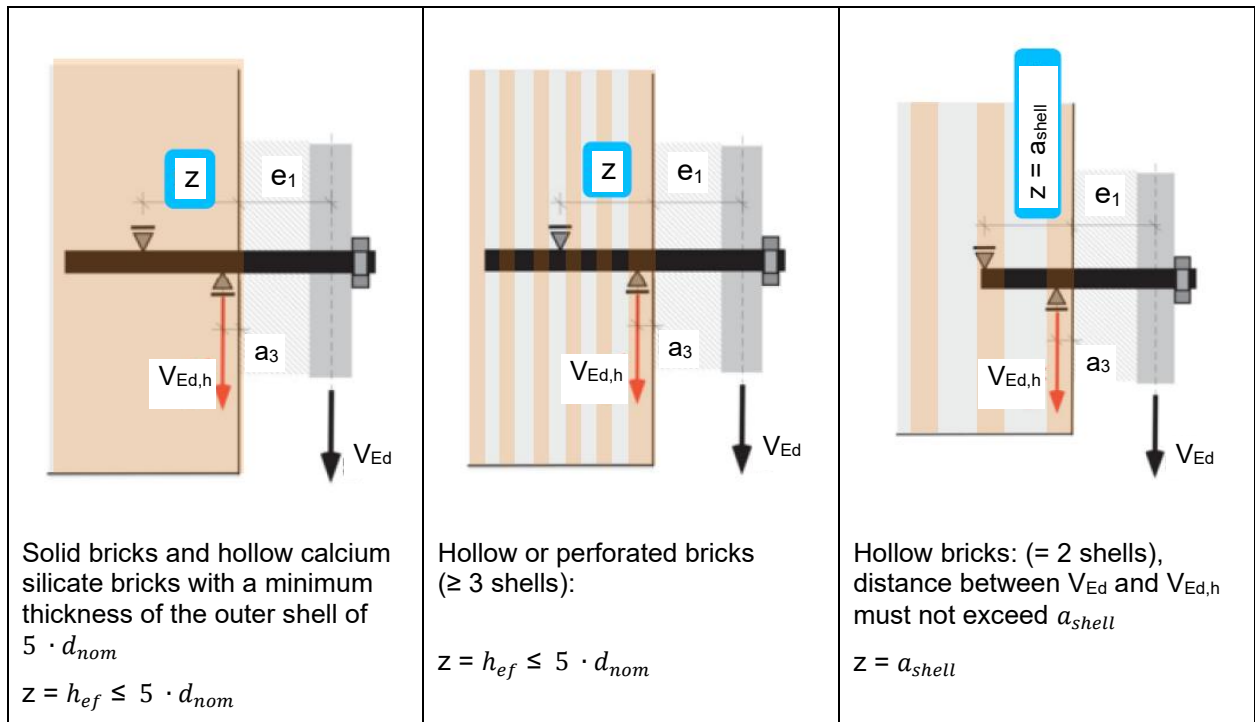

Figure 3.3: Inner lever arm in the base material

4 VERIFICATION ULTIMATE LIMIT STATE (STATIC AND QUASI-STATIC ACTIONS)

4.1 General

Spacing, edge distance as well as thickness of member shall not remain under the given minimum values in the ETA.

4.2 Resistance to tension loads

4.2.1 Required proofs

Failure of the metal part	$N_{Ed}^h \leq N_{Rk,s} / \gamma_{Ms}$	4.2.2
Pull-out failure of the anchor	$N_{Ed}^h \leq N_{Rk,p} / \gamma_{Mm}$ $N_{Ed}^h \leq N_{Rk,p,c} / \gamma_{Mm}$	4.2.3
Brick breakout failure	$N_{Ed} \leq N_{Rk,b} / \gamma_{Mm}$ $N_{Ed} \leq N_{Rk,b,c} / \gamma_{Mm}$ $N_{Ed}^g \leq N_{Rk,b}^g / \gamma_{Mm}$	4.2.4
Brick pull-out and combined failure	$N_{Ed} \leq N_{Rk,pb} / \gamma_{Mm}$	4.2.5
Influence of joints	$N_{Ed}^h \leq \alpha_{j,N} N_{Rk,p} / \gamma_{Mm}$ $N_{Ed} \leq \alpha_{j,N} N_{Rk,b} / \gamma_{Mm}$ $N_{Ed}^g \leq \alpha_{j,N} N_{Rk,b}^g / \gamma_{Mm}$	4.2.6

For anchorages in AAC the partial factor γ_{MAAC} is to be used instead of γ_{Mm} .

4.2.2 Failure of the metal part

The characteristic resistance of an anchor in case of failure of the metal part $N_{Rk,s}$ is given in the relevant ETA. In case of no characteristic resistance is given in the ETA, the following equations may be applied.

$$N_{Rk,s} = A_s \cdot f_{uk} \quad (4.1)$$

with: A_s = decisive cross section of the anchor
 f_{uk} = nominal characteristic steel ultimate strength

4.2.3 Pull-out failure of the anchor

The characteristic resistance in case of failure by pull-out of the anchor $N_{Rk,p}$ and $N_{Rk,p,c}$ and the corresponding values for spacing and edge distance $s_{cr,II}$, $s_{cr,+}$ and c_{cr} or c_{min} are given in the relevant ETA.

The corresponding distances of screw anchors to joints $c_{j,II}$ and $c_{j,\pm}$ are given in the relevant ETA.

4.2.4 Brick breakout failure

The characteristic resistance of one anchor in case of brick breakout failure $N_{Rk,b}$ and $N_{Rk,b,c}$ and the corresponding values for spacing and edge distance $s_{cr,II}$, $s_{cr,+}$ and c_{cr} or c_{min} are given in the relevant ETA.

The characteristic resistance of a group of two or four anchors $N_{Rk,b}^g$ and the corresponding values for spacing and edge distance $s_{min,II}$, $s_{min,+}$ and c_{min} are given in the relevant ETA.

The corresponding distances of screw anchors to joints $c_{j,II}$ and $c_{j,\pm}$ are given in the relevant ETA.

Unless otherwise specified in the ETA, the characteristic resistance of a group with spacing smaller than $s_{cr,II}$ and $s_{cr,\pm}$ ($s_{min} \leq s \leq s_{cr}$) can be assumed to be at least the characteristic resistance of a corresponding single anchor.

4.2.5 Brick pull-out and combined failure

The characteristic resistance of an anchor or a group of anchors in case of pull out of one brick $N_{Rk,pb}$ is calculated as follows:

Vertical joints are not filled with mortar

$$N_{Rk,pb} = 2 \cdot l_{brick} \cdot b_{brick} (0,5 \cdot f_{vko} + 0,4 \cdot \sigma_d) \quad (4.2)$$

Vertical joints are filled with mortar depending on the area of the vertical joint according to Figure 4.1

$$N_{Rk,pb} = 2 \cdot l_{brick} \cdot b_{brick} (0,5 \cdot f_{vko} + 0,4 \cdot \sigma_d) + 2 \cdot A_{vertical\ joint} \cdot 0,5 \cdot f_{vko} \quad (4.3)$$

with: $N_{Rk,pb}$ = characteristic resistance for pull out of one brick

l_{brick} = length of the brick

b_{brick} = breadth of the brick

h_{brick} = height of the brick

$A_{vertical\ joint}$ = area of vertical joint according to Figure 4.1

σ_d = minimum design compressive stress perpendicular to the shear

f_{vko} = initial shear strength according to EN 1996 1-1 [4], Table 3.4

Note: The factor 0,5 regarding f_{vko} considers the difference between the shear strength of a wall given in the EN 1996 1-1 [4], Table 3.4 and the shear strength of only one brick in case of pull out.



$$A_{vertical\ joint} = h_{brick} \cdot b_{brick}$$



$$A_{vertical\ joint} = h_{brick} \cdot l_{brick}$$

Figure 4.1: Area of vertical joint

In case of multiple wythes walls where anchoring in more than one wythe is allowed, pull-out of more than one brick as well as a combination of brick pull-out and pull-out failure of the anchor or brick breakout failure can occur (see Figure 4.2). For design purposes, the least of these resistances is decisive and the characteristic resistance of an anchor or a group of anchors in case of combined brick pull-out failure, $N_{Rk,pb2}$, is calculated as given by Equation (4.4).

Note: The wall layout (masonry bond) may provide different resistances depending on the anchoring location (e.g., in stretcher or header rows in case of English bond). If information on the masonry layout is not available, the decisive resistance shall be the taken as the least among all possible combinations.

$$N_{Rk,pb2} = \min \{ n \cdot N_{Rk,pb}; (n - 1) \cdot N_{Rk,pb} + N_{Rk,ETA} (h_{ef,2}) \} \quad (4.4)$$

with: n = number of bricks activated (e.g. $n = 2$ in Figure 4.1)

$N_{Rk,pb}$ = characteristic resistance for pull-out of one brick according to equation (4.2) or (4.3)

$$N_{Rk,ETA} (h_{ef,2}) = \min(N_{Rk,p}; N_{Rk,b})$$

characteristic resistance for anchor pull-out failure or brick breakout failure as given in the relevant ETA for a single anchor or an anchor group for embedment depth $h_{ef,2}$ or the next smaller $h_{ef,2}$

$h_{ef,2}$ = effective anchorage depth in the rearmost brick (compare Figure 4.2b))

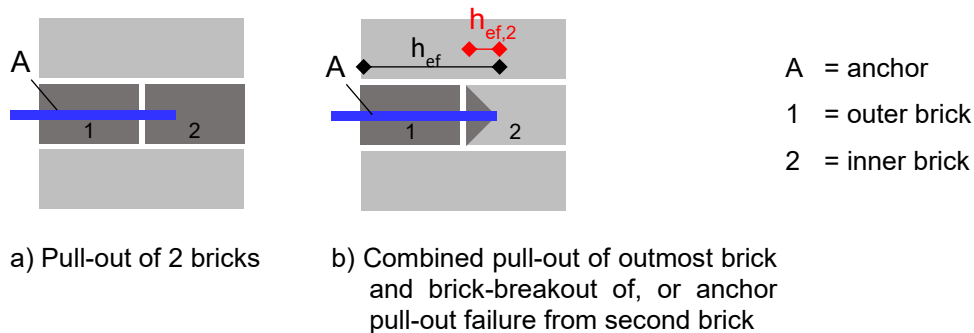

Figure 4.2: Failure modes for deep embedment depth activating more than one brick (wythe); example for one anchor and 2 activated bricks

4.2.6 Influence of joints

The information on the consideration of joints is given in the corresponding ETA. If no information is given in the ETA, the following specification can be applied:

The characteristic resistance $N_{Rk,p}$, $N_{Rk,b}$ and $N_{Rk,b}^g$ for setting positions in bricks may be used if the joints of the masonry are completely filled with mortar.

Metal injection anchors:

If the joints of the masonry are not completely filled with mortar and the distance to the joint is $c \geq c_{min}^*$ then the characteristic resistances $N_{Rk,p,c}$, $N_{Rk,b,c}$ and $N_{Rk,b}^g$ may be used.

If the joints of the masonry are not completely filled with mortar and the minimum edge distance to the joint is $c < c_{min}^*$ then the characteristic resistance $N_{Rk,p}$, $N_{Rk,b}$ and $N_{Rk,b}^g$ has to be reduced by the factor $\alpha_{j,N} = 0,75$.

Screw anchors:

The characteristic resistances $N_{Rk,p,c}$, $N_{Rk,b,c}$ and $N_{Rk,b}^g$ may be used only if the distance to the joint is $c \geq c_j$.

If the width of joints is smaller or equal to w_j (given in the ETA) and the distance to the joint is $c < c_j$ then the characteristic resistances $N_{Rk,p}$, $N_{Rk,b}$ and $N_{Rk,b}^g$ have to be reduced by the factor $\alpha_{j,N}$ given in the ETA.

4.3 Resistance to shear loads

4.3.1 Required proofs

Failure of the metal part, shear load without lever arm	$V_{Ed}^h \leq V_{Rk,s} / \gamma_{Ms}$	4.3.2
Failure of the metal part, shear load with lever arm	$V_{Ed}^h \leq V_{Rk,s,M} / \gamma_{Ms}$	4.3.3
Local brick failure, shear load without lever arm	$V_{Ed} \leq V_{Rk,b} / \gamma_{Mm}$ $V_{Ed}^g \leq V_{Rk,b}^g / \gamma_{Mm}$	4.3.4
Local brick failure, shear load with lever arm	$V_{Ed,h} \leq V_{Rk,b} / \gamma_{Mm}$	4.3.4
Brick edge failure, shear load without lever arm	$V_{Ed} \leq V_{Rk,c} / \gamma_{Mm}$ $V_{Ed}^g \leq V_{Rk,c}^g / \gamma_{Mm}$	4.3.5
Brick edge failure, shear load with lever arm	$V_{Ed,h} \leq V_{Rk,c} / \gamma_{Mm}$	4.3.5
Pushing out of one brick	$V_{Ed} \leq V_{Rk,pb} / \gamma_{Mm}$	4.3.6
Influence of joints	$V_{Ed} \leq \alpha_{j,V} V_{Rk,b} / \gamma_{Mm}$ $V_{Ed}^g \leq \alpha_{j,V} V_{Rk,b}^g / \gamma_{Mm}$	4.3.7

For anchorages in AAC the partial factor γ_{MAAC} is to be used instead of γ_{Mm} .

4.3.2 Failure of the metal part, shear load without lever arm

The characteristic resistance of an anchor in case of failure of the metal part due to shear load without lever arm $V_{Rk,s}$ shall be taken from the relevant ETA.

In case of no characteristic resistance is given in the ETA, the following Equation may be applied.

$$V_{Rk,s} = 0,5 \cdot A_s \cdot f_{uk} \quad (4.5)$$

with: A_s = decisive cross section of the anchor
 f_{uk} = nominal characteristic steel ultimate strength

4.3.3 Failure of the metal part, shear load with lever arm

The characteristic resistance of an anchor in case of failure of the metal part due to shear load with lever arm $V_{Rk,s,M}$ is given by following Equation:

$$V_{Rk,s,M} = \frac{\alpha_M \cdot M_{Rk,s}}{l} \quad (4.6)$$

with: l = lever arm according to Equation (3.1)
 α_M = depends on the degree of restraint of the anchor at the side of the fixture of the application, see Equation (3.1)
 $M_{Rk,s} = M_{Rk,s}^0 \left(1 - \frac{N_{Ed}}{N_{Rd,s}}\right)$
 $M_{Rk,s}^0$ = taken from the relevant ETA
 N_{Ed} = design value of actions under tension load
 $N_{Rd,s}$ = design value of resistance to steel failure of the anchor under tension load

4.3.4 Local brick failure

The characteristic resistance of one anchor in case of local brick failure $V_{Rk,b}$ and the corresponding values for spacing and edge distance s_{crII} , $s_{cr\pm}$ and c_{cr} or c_{min} are given in the relevant ETA.

The characteristic resistance of a group of two or four injection anchors $V_{Rk,b}^g$ and the corresponding values for spacing and edge distance s_{minII} , $s_{min\pm}$ and c_{min} are given in the relevant ETA.

Unless otherwise specified in the ETA, the characteristic resistance of a group with spacing smaller than s_{crII} and $s_{cr\pm}$ ($s_{min} \leq s \leq s_{cr}$) can be assumed to be at least the characteristic resistance of a corresponding single anchor.

4.3.5 Brick edge failure

The characteristic resistance for an anchor in the case of brick edge failure $V_{Rk,c}$ and the corresponding values for spacing and edge distance s_{crII} , $s_{cr\pm}$ and c_{cr} or c_{min} are given in the relevant ETA.

In case no characteristic resistance is given in the ETA, the following equations may be applied.

For anchorages in solid masonry and AAC the following determination may be used:

$$V_{Rk,c} = k \cdot \sqrt{d_{nom}} \cdot (h_{nom}/d_{nom})^{0,2} \cdot \sqrt{f_b} \cdot c^{1,5} \quad (4.7)$$

with: k = 0,25 if load direction is to the free edge
 = 0,45 if load direction is parallel to the free edge
 c = edge distance closest to the edge in mm
 $c \geq c_{min}$

If the anchor is located in the outmost brick towards an edge, the load is directed to the free edge and no load transfer to other adjacent units (top and bottom side) in the wall is given, then the following conditions shall be fulfilled:

$$c \leq (b_{brick} / 1,5; h_{brick} / 3)$$

- d_{nom} = outside diameter of the anchor in mm
 h_{nom} = overall anchor embedment depth in mm
 f_b = normalized mean compressive strength of masonry unit in N/mm²

For anchorages in hollow or perforated masonry the following values correspond to current experience and no further determination is required:

- $V_{Rk,c}$ = 2,50 kN if load direction is parallel to the free edge with $c \geq 100$ mm and $c \geq 6 d_0$ and
if load direction is to the free edge with $c \geq 250$ mm
 $V_{Rk,c}$ = 1,25 kN if load direction is to the free edge with $c \geq 100$ mm and $c \geq 6 d_0$
Intermediate values can be interpolated.

The characteristic resistance of a group of two or four injection anchors $V_{Rk,c}^g$ and the corresponding values for spacing and edge distance s_{minII} , s_{min+} and c_{min} are given in the relevant ETA. On the safe side the characteristic resistance of a group with spacing smaller than s_{crII} and s_{cr+} ($s_{min} \leq s \leq s_{cr}$) can be assumed to be at least the characteristic resistance of a corresponding single anchor.

4.3.6 Pushing out of one brick

The characteristic resistance of an anchor or a group of anchors in case of pushing out of one brick on the free edge of a wall $V_{Rk,pb}$ is calculated as follows:

$$V_{Rk,pb} = 2 \cdot l_{brick} \cdot b_{brick} (0,5 \cdot f_{vko} + 0,4 \cdot \sigma_d) \quad (4.8)$$

with: $V_{Rk,pb}$ = characteristic resistance for pull out of one brick

l_{brick} = length of the brick

b_{brick} = breadth of the brick

h_{brick} = height of the brick

σ_d = minimum design compressive stress perpendicular to the shear

f_{vko} = initial shear strength according to EN 1996 1-1 [4], Table 3.4

4.3.7 Influence of joints

The information on the consideration of joints is given in the corresponding ETA. If no information is given in the ETA, the following specification can be applied:

The characteristic resistance $V_{Rk,b}$, $V_{Rk,c}$, $V_{Rk,b}^g$ and $V_{Rk,c}^g$ for setting positions in bricks may be used if the joints of the masonry are completely filled with mortar.

Metal injection anchors:

If the joints of the masonry are not completely filled with mortar then the joints have to be considered as a free edge and the minimum edge distance to the joint has to be $c \geq c_{min}^*$.

Screw anchors:

The characteristic resistances $V_{Rk,b}$ and $V_{Rk,b}^g$ may be used only if the distance to the joint is $c \geq c_j$.

If the width of joints is smaller or equal to w_j (given in the ETA) and the distance to the joint is $c < c_j$ then the characteristic resistances $V_{Rk,b}$ and $V_{Rk,b}^g$ have to be reduced by the factor $\alpha_{j,v}$ given in the ETA.

4.4 Resistance to combined tension and shear loads

For combined tension and shear loads the following equations shall be satisfied:

$$\beta_N \leq 1,0 \quad (4.9)$$

$$\beta_V \leq 1,0 \quad (4.10)$$

$$\beta_N + \beta_V \leq 1,2 \text{ for solid masonry} \quad (4.11)$$

$$\beta_N + \beta_V \leq 1,0 \text{ for perforated or hollow masonry for injection anchors} \quad (4.12)$$

$$\beta_N + \beta_V \leq X \text{ for perforated or hollow masonry for screw anchors} \quad (4.13)$$

with: β_N (β_V) = ratio between design action and design resistance for tension (shear) loading.
In Equations (4.9) to (4.12) the largest value of β_N and β_V for the different failure modes shall be taken (see 4.2.1 and 4.3.1).

X according to ETA of the screw anchor

4.5 Additional provisions for prefabricated reinforced components made of autoclaved aerated concrete

For prefabricated reinforced components made of autoclaved aerated concrete the following has to be taken into account as well, if no special tests or calculation for the resistance of the member made of autoclaved aerated concrete have been carried out:

The design value of shear resistance in the member caused by the anchorage is less than or equal to 40 % of the design value of resistance of the member in the critical cross section.

The edge distance c is ≥ 150 mm for slabs of width ≤ 700 mm.

The spacing of fixing points in general is ≥ 250 mm. For prefabricated reinforced components of autoclaved aerated concrete, the spacing of fixing points is ≥ 600 mm. Fixing points are single anchors or groups of 2 or 4 anchors.

5 VERIFICATION FOR FIRE RESISTANCE

5.1 General

The fire resistance (stated in the ETA) is classified according to EN 13501-2 [8] using the Standard ISO time-temperature curve (STC).

The determination covers anchors with a fire attack from one side only. If the fire attack is from more than one side, the design method may be taken only, if the edge distance of the anchor to the free edge is $c \geq 300 \text{ mm}$ and $c \geq 2 h_{ef}$ (for injection anchors) or $c \geq 2 h_{nom}$ (for screw anchors).

The required spacing and edge distance for anchorages under fire exposure are given in the relevant ETA.

The design method covers single injection anchors and single screw anchors or screw anchor groups under fire exposure.

5.2 Resistance to tension loads

5.2.1 Required proofs

Failure of the metal part	$N_{Ed,fi}^h \leq N_{Rk,s,fi} / \gamma_{M,fi}$	5.2.2
Pull-out failure of the anchor	$N_{Ed,fi}^h \leq N_{Rk,p,fi} / \gamma_{M,fi}$	5.2.3
Brick breakout failure	$N_{Ed,fi} \leq N_{Rk,b,fi} / \gamma_{M,fi}$	5.2.4
	$N_{Ed,fi}^g \leq N_{Rk,b,fi}^g / \gamma_{M,fi}$	
Pull-out of one brick	$N_{Ed,fi} \leq N_{Rk,pb,fi} / \gamma_{M,fi}$	5.2.5
Influence of joints		5.2.6

5.2.2 Resistance to steel failure

The characteristic resistance of an anchor in case of failure of the metal part $N_{Rk,s,fi}$ is given in the relevant ETA.

5.2.3 Pull-out failure

Metal injection anchors:

The characteristic resistance in case of failure by pull-out of the anchor $N_{Rk,p,fi}$ and the corresponding edge distances $c_{cr,fi}$ shall be taken from the relevant ETA.

Screw anchors:

The characteristic resistance in case of failure by pull-out of the anchor $N_{Rk,p,fi}$ and the corresponding edge distances and joint distances $c_{min,fi}$, $c_{j,fi}$ are given in the relevant ETA.

5.2.4 Brick break out failure

Metal injection anchors:

The characteristic resistance in case of failure by pull-out of the anchor $N_{Rk,b,fi}$ and $N_{Rk,b,fi}^g$ and the corresponding edge distances and spacings $c_{cr,fi}$ and $s_{cr,fi}$ shall be taken from the relevant ETA.

Screw anchors:

The characteristic resistance in case of failure by brick break out of the anchor $N_{Rk,b,fi}$ and $N_{Rk,b,fi}^g$ and the corresponding edge distances, joint distances and spacings $c_{min,fi}$, $c_{j,fi}$, $s_{min,fi}$ are given in the relevant ETA.

5.2.5 Pull-out of one brick

Vertical joints are not filled with mortar

$$N_{Rk,pb,fi} = 2 \cdot l_{brick} \cdot (b_{brick} - t_{ineff}) \cdot (0,5 \cdot f_{vko} + 0,4 \cdot \sigma_d) \quad (5.1)$$

Vertical joints are filled with mortar

$$N_{Rk,pb,fi} = 2 \cdot l_{brick} \cdot (b_{brick} - t_{ineff}) \cdot (0,5 \cdot f_{vko} + 0,4 \cdot \sigma_d) + 2 \cdot l_{brick} \cdot h_{brick} \cdot 0,5 \cdot f_{vko} \quad (5.2)$$

with: $N_{Rk,pb,fi}$ = characteristic resistance for pull out of one brick under fire exposure

t_{ineff} = ineffective thickness of mortar in joints under fire exposure

$$t_{ineff,fi,30} = 25 \text{ mm}$$

$$t_{ineff,fi,60} = 40 \text{ mm}$$

$$t_{ineff,fi,90} = 60 \text{ mm}$$

$$t_{ineff,fi,120} = 80 \text{ mm}$$

$l_{brick}, b_{brick}, h_{brick}, \sigma_d, f_{vko}$ see Equation (4.3)

5.2.6 Influence of joints

The information on the consideration of joints is given in the corresponding ETA. If no information is given in the ETA, the following specification can be applied:

The characteristic resistance $N_{Rk,p,fi}, N_{Rk,b,fi}$ for setting positions in bricks may be used only if the joints of the masonry are completely filled with mortar.

Screw anchors

The distance to joints has to be $c \geq c_{j,fi}$.

5.3 Resistance to shear loads

5.3.1 Required proofs

Failure of the metal part, shear load without lever arm	$V_{Ed,fi} \leq V_{Rk,s,fi} / \gamma_{M,fi}$	5.3.2
Failure of the metal part, shear load with lever arm	$V_{Ed,fi} \leq V_{Rk,s,M,fi} / \gamma_{M,fi}$	5.3.3
Local brick failure	$V_{Ed,fi} \leq V_{Rk,b,fi} / \gamma_{M,fi}$ $V_{Ed,fi}^g \leq V_{Rk,b,fi}^g / \gamma_{M,fi}$	5.3.4
Pushing out of one brick	$V_{Ed,fi} \leq V_{Rk,pb,fi} / \gamma_{M,fi}$	5.3.5
Influence of joints		5.3.6

5.3.2 Failure of the metal part, shear load without lever arm

The characteristic resistance of an anchor in case of failure of the metal part $V_{Rk,s,fi}$ is given in the relevant ETA.

5.3.3 Failure of the metal part, shear load with lever arm

The characteristic resistance of an anchor in case of failure of the metal part $M_{Rk,s,fi}^0$ is given in the relevant ETA.

The characteristic resistance of an anchor in case of failure of the metal part due to shear load with lever arm $V_{Rk,s,M,fi}$ is given by following Equation:

$$V_{Rk,s,M,fi} = \frac{\alpha_M \cdot M_{Rk,s,fi}}{l} \quad (5.3)$$

with: l = lever arm according to Equation (3.1)

α_M = depends on the degree of restraint of the anchor at the side of the fixture of the application, see Equation (3.1)

$$M_{Rk,s,fi} = M_{Rk,s,fi}^0 \left(1 - \frac{N_{Ed}}{N_{Rd,s}}\right)$$

$M_{Rk,s,fi}^0$ = taken from the relevant ETA

N_{Ed} = design value of actions under tension load in case of fire

$N_{Rd,s}$ = design value of resistance to steel failure of the anchor under tension load in case of fire

5.3.4 Local brick failure

The characteristic resistance in case of local brick failure under fire exposure may be obtained according to following equations:

$$V_{Rk,b,fi} = N_{Rk,b,fi} \quad (5.4)$$

$$V_{Rk,b,fi}^g = N_{Rk,b,fi}^g \quad (5.5)$$

with: $N_{Rk,b,fi}$ = shall be taken from the relevant ETA

$N_{Rk,b,fi}^g$ = given in the relevant ETA

5.3.5 Pushing out of one brick

The characteristic resistance of an anchor or a group of anchors in case of pushing out of one brick on the free edge of a wall $V_{Rk,pb,fi}$ is calculated as follows:

$$V_{Rk,pb,fi} = 2 \cdot l_{brick} \cdot (b_{brick} - t_{ineff}) \cdot (0,5 \cdot f_{vko} + 0,4 \cdot \sigma_d) \quad (5.6)$$

with: $V_{Rk,pb,fi}$ = characteristic resistance for pull out of one brick under fire exposure

t_{ineff} = ineffective thickness of mortar in joints under fire exposure

$$t_{ineff,fi,30} = 25 \text{ mm}$$

$$t_{ineff,fi,60} = 40 \text{ mm}$$

$$t_{ineff,fi,90} = 60 \text{ mm}$$

$$t_{ineff,fi,120} = 80 \text{ mm}$$

$l_{brick}, b_{brick}, h_{brick}, \sigma_d, f_{vko}$ see Equation (4.8)

5.3.6 Influence of joints

The information on the consideration of joints is given in the corresponding ETA. If no information is given in the ETA, the following specification can be applied:

The characteristic resistance $V_{Rk,b,fi}$ for setting positions in bricks may be used if the joints of the masonry are completely filled with mortar.

Screw anchors

The distance to the joint has to be $c \geq c_{j,fi}$.

5.4 Resistance to combined tension and shear loads

The interaction condition according to normal temperature according to 4.4 may be taken with the characteristic resistance under fire exposure for the different loading directions for combined tension and shear loads.

6 VERIFICATION FOR INJECTION ANCHORS UNDER SEISMIC ACTIONS

6.1 General

The following types of connections are distinguished:

- Type 'A' - connection between structural elements of primary and/or secondary seismic members.

Note: Design of new masonry structures shall comply with EN 1998-1 [5], especially section 9.5.2, where applicable. Design of existing masonry structure shall also comply with EN 1998-3 [10].

- Type 'B' - attachment of non-structural elements.

In cases of very low seismicity according to EN 1998-1 [5] it shall be permitted to design as for permanent and transient situations (see section 4).

6.2 Design and safety concept

6.2.1 Ultimate limit state

The design resistance under seismic actions is calculated according to Equation (2.2).

In the absence of national regulations, the recommended values for partial factors for fastenings under seismic loading $\gamma_{M,eq}$ are identical to the corresponding values for static loading (see section 2.2).

6.2.2 Damage limitation state

In the damage limitation state, it shall be shown that the displacements occurring under the relevant actions are not larger than the admissible displacement. The admissible displacement depends on the application under consideration and shall be evaluated by the design engineer.

6.3 Requirements

Anchors used to resist seismic actions shall meet all applicable requirements for non-seismic applications.

Only anchors assessed according to EAD 330076-01-0604-v01 [9] shall be used. The masonry in the region of the fastening is assumed to be cracked when determining design resistances.

The provisions in this section do not apply to the design of fastenings in critical regions of masonry members where large cracks (>0,5mm) might occur during seismic events as e.g., in the diagonals of shear walls.

An annular gap between an anchor and its fixture should be avoided in seismic design situations. For fastenings of non-structural elements in minor non-critical applications an annular gap (diameter d_f of the clearance hole in the fixture not larger than the value given in Table 3.1) is allowed. The effect of the annular gap on the behaviour of fastenings shall be taken into account (see 6.7.2).

Displacement of the fastening shall be accounted for in the design. This requirement does not need to be applied to anchoring of non-structural elements of minor importance. The displacement shall be limited when a rigid connection is assumed in the analysis or when the operability of the attached element during and after an earthquake shall be ensured.

Note: Information on anchor displacements for seismic applications at both damage limitation state and ultimate limit state is provided in the relevant ETA.

Loosening of the nut or screw shall be prevented by appropriate measures.

Fastenings where shear loads act on anchors with a lever arm, such as e.g., in stand-off installation or with a grout layer $\geq 0,5 \cdot d$, are not covered (compare section 3.2).

6.4 Design options

In the design of fastenings one of the following options a1) or a2) shall be satisfied (for details see also 6.5):

The design shall be carried out without requirements on the ductility of the anchors. It shall be assumed that anchors are non-dissipative elements, and they are not able to dissipate energy by means of ductile hysteretic behaviour and that they do not contribute to the overall ductile behaviour of the structure.

- a1) Capacity design: The anchor or group of anchors is designed for the maximum tension and/or shear load that can be transmitted to the fastening based on either the development of a ductile yield mechanism in the fixture or the attached element taking into account strain hardening and material over-strength or the capacity of a non-yielding attached element.
- a2) Elastic design: The fastening is designed for the maximum load obtained from the design load combinations that include seismic actions E_{Ed} corresponding to the ultimate limit state (see EN 1998-1 [5]) assuming elastic behaviour of the fastening and of the structure. Furthermore, uncertainties in the model to derive seismic actions on the fastening shall be taken into account.

6.5 Design criteria

For the design of anchors according to 6.4, option a1) 'capacity design', for both Type 'A' and Type 'B' connections, the fastening is designed for the maximum load that can be transmitted to the fastening based either on the development of a ductile yield mechanism in the attached steel component (see Figure 6.1 a)) or in the steel base plate (see Figure 6.2 b)) taking into account strain hardening and material overstrength effects, or on the capacity of a non-yielding attached component or structural element (see Figure 6.1 c)).

The assumption of a plastic hinge in the fixture (see Figure 6.1 b)) requires to take into account specific aspects including e.g., the redistribution of loads to the individual anchors of a group, the redistribution of the loads in the structure and the low cycle fatigue behaviour of the fixture.

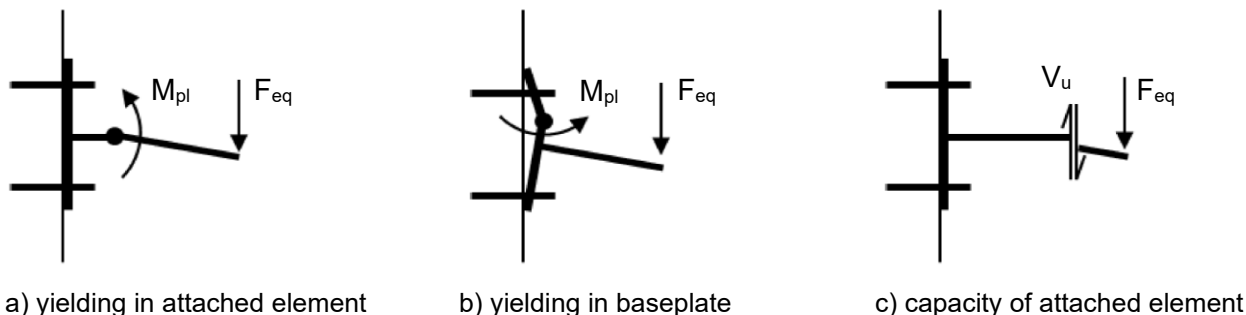

Figure 6.1: Seismic design by protection of the fastening

For the design of anchors according to 6.4, option a2) 'elastic design' the action effects for Type 'A' connections shall be derived according to EN 1998-1 [5] with a behaviour factor $q_a = 1,0$. For Type 'B' connections the action effects shall be derived with $q_a = 1,0$ for the attached element. q_a is defined as the behaviour factor for non-structural elements. If action effects are derived in accordance with the simplified approach given in 6.6.4 with $q_a = 1,0$, they shall be multiplied by an amplification factor equal to 1,5. If the action effects are derived from a more precise model, this additional amplification may be omitted.

6.6 Derivation of forces action on anchors

6.6.1 General

The design value of the effect of seismic actions E_{Ed} acting on the fixture shall be determined according to EN 1998-1 [5] and section 6.4 as applicable. Provisions in addition to EN 1998-1 [5] including vertical seismic actions acting on non-structural elements are provided in this Section.

The maximum value of each action effect (tension and shear component of forces per anchor) shall be considered to act simultaneously if no other more accurate model is used for the estimation of the probable simultaneous value of each action effect.

6.6.2 Addition to EN 1998-1 [5], 4.3.3.5

For the design of the anchors in Type 'A' connections the vertical component of the seismic action shall be taken into account according to EN 1998-1 [5], Section 4.3.3.5.2 (2) to (4) if the vertical design ground acceleration a_{vg} is greater than 2,5 m/s².

6.6.3 Addition to EN 1998-1 [5], 4.3.5.1

In the design of fastenings for non-structural elements (Type 'B' connections) subjected to seismic actions, any beneficial effects of friction due to gravity loads should be ignored.

6.6.4 Addition and alterations to EN 1998-1 [5], 4.3.5.2

The horizontal effects of the seismic action of non-structural elements are determined according to Equation (4.24) of EN 1998-1 [5]. However, the behaviour factor q_a may be taken from Table 6.1.

Note: Table 6.1 includes information in addition to the values q_a given in EN 1998-1 [5], Table 4.4.

Table 6.1: Values of q_a and A_a for non-structural elements

Type of non-structural element	q_a	A_a
Cantilevering parapets or ornamentations	1,0	3,0
Signs and billboards		3,0
Chimneys, masts and tanks on legs acting as unbraced cantilevers along more than one half of their total height		3,0
Hazardous material storage, hazardous fluid piping		3,0
Exterior and interior walls	2,0	1,5
Partitions and facades		1,5
Chimneys, masts and tanks on legs acting as unbraced cantilevers along less than one half of their total height, or braced or guyed to the structure at or above their centre of mass		1,5
Elevators		1,5
Computer access floors, electrical and communication equipment		3,0
Conveyors		3,0
Anchorage elements for permanent cabinets and book stacks supported by the floor		1,5
Anchorage elements for false (suspended) ceilings and light fixtures		1,5
High pressure piping, fire suppression piping		3,0
Fluid piping for non-hazardous materials		3,0
Computer, communication and storage racks		3,0

Equation (4.25) of EN 1998-1 [5] for the seismic coefficient S_a may be rearranged as:

$$S_a = \alpha \cdot S \cdot \left[\left(1 + \frac{z}{H} \right) \cdot A_a - 0,5 \right] \tag{6.1}$$

with: α = ratio of the design ground acceleration on type A ground, a_g , to the acceleration of gravity g

S = soil factor

z = height of the non-structural element above the level of application of the seismic action (foundation or top of a rigid basement)

H = building height measured from the foundation or from the top of a rigid basement

$$A_a = \frac{3}{1 + \left(1 - \frac{T_a}{T_l} \right)^2} \tag{6.2}$$

T_a = fundamental vibration period of the non-structural element

T_l = fundamental vibration period of the building in the relevant direction

The seismic amplification factor A_a may be calculated according to Equation (6.2) or taken from Table 6.1 if one of the fundamental vibration periods is not known.

Note: When calculating the forces acting on non-structural elements according to Equation (4.25) of EN 1998-1 [5], it can often be difficult to establish with confidence the fundamental vibration period T_a of the non-structural element. Table 6.1 provides a pragmatic approach and may not be conservative in all cases.

The vertical effects of the seismic action should be determined by applying to the non-structural element a vertical force F_{Va} acting at the centre of mass of the non-structural element which is defined as follows:

$$F_{Va} = (S_{Va} \cdot W_a \cdot \gamma_a) / q_a \tag{6.3}$$

- with: $S_{Va} = \alpha_V \cdot A_a$
 α_V = ratio of the vertical ground acceleration on type A ground, a_{vg} , to the acceleration of gravity g
 W_a = weight of the element
 γ_a = importance factor of the element, see EN 1998-1 [5], Section 4.3.5.3
 q_a, A_a may be assumed to be equal to the values valid for horizontal forces

Note: The vertical effects of the seismic action F_{Va} for non-structural elements may be neglected for the anchor when the ratio of the vertical component of the design ground acceleration a_{vg} to the acceleration of gravity g is less than 0,25 and the gravity loads are transferred through direct bearing of the fixture on the structure (see fastening 2 in Figure 6.2).

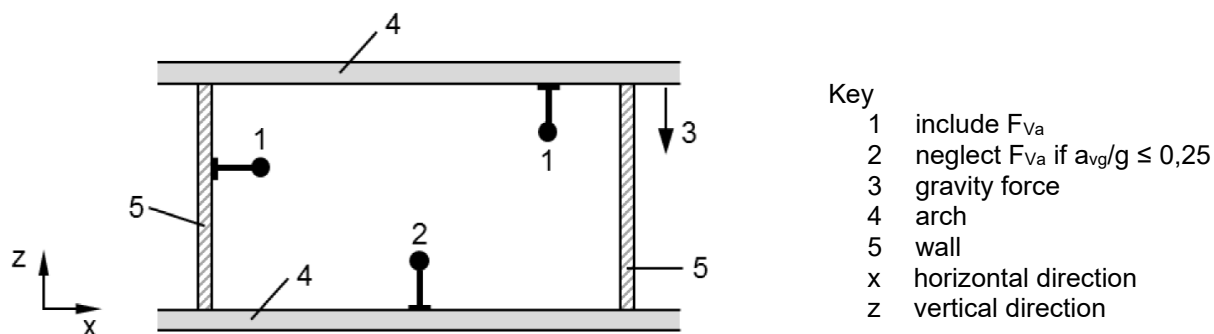

Figure 6.2: Examples for vertical effects of the seismic action

6.6.5 Addition to EN 1998-1 [5], 4.3.5.4

Upper values for the behaviour factor q_a for non-structural elements may be selected from Table 6.1.

6.7 Resistance to tension and shear loads and combined tension and shear loads

6.7.1 Required verifications for tension and shear loading

Tension loading	Failure of the metal part	$N_{Ed,eq}^h \leq \alpha_{eq} \cdot N_{Rk,s,eq} / \gamma_{Ms}$
	Pull-out failure of the anchor	$N_{Ed,eq}^h \leq \alpha_{eq} \cdot N_{Rk,p,eq} / \gamma_{Mm}$
	Brick breakout failure	$N_{Ed,eq} \leq \alpha_{eq} \cdot N_{Rk,b,eq} / \gamma_{Mm}$
		$N_{Ed,eq}^g \leq \alpha_{eq} \cdot N_{Rk,b,eq}^g / \gamma_{Mm}$
	Brick pull-out and combined failure	$N_{Ed,eq} \leq \alpha_{eq} \cdot N_{Rk,pb} / \gamma_{Mm}$
Influence of joints	$N_{Ed,eq}^h \leq \alpha_{eq} \cdot \alpha_{j,N} \cdot N_{Rk,p,eq} / \gamma_{Mm}$	
	$N_{Ed,eq} \leq \alpha_{eq} \cdot \alpha_{j,N} \cdot N_{Rk,b,eq} / \gamma_{Mm}$	
	$N_{Ed,eq}^g \leq \alpha_{eq} \cdot \alpha_{j,N} \cdot N_{Rk,b,eq}^g / \gamma_{Mm}$	

Shear loading	Failure of the metal part, shear load without lever arm	$V_{Ed,eq}^h \leq \alpha_{gap} \cdot \alpha_{eq} \cdot V_{Rk,s,eq} / \gamma_{Ms}$
	Failure of the metal part, shear load with lever arm	Not covered for seismic actions
	Local brick failure	$V_{Ed,eq} \leq \alpha_{gap} \cdot \alpha_{eq} \cdot V_{Rk,b,eq} / \gamma_{Mm}$ $V_{Ed,eq}^g \leq \alpha_{gap} \cdot \alpha_{eq} \cdot V_{Rk,b,eq}^g / \gamma_{Mm}$
	Brick edge failure	$V_{Ed,eq} \leq \alpha_{gap} \cdot \alpha_{eq} \cdot V_{Rk,c,eq} / \gamma_{Mm}$ $V_{Ed,eq}^g \leq \alpha_{gap} \cdot \alpha_{eq} \cdot V_{Rk,c,eq}^g / \gamma_{Mm}$
	Pushing out of one brick	$V_{Ed,eq} \leq \alpha_{gap} \cdot \alpha_{eq} \cdot V_{Rk,pb} / \gamma_{Mm}$
	Influence of joints	Section 4.3.7 applies, using $V_{Rk,b,eq}$, $V_{Rk,c,eq}$, $V_{Rk,b,eq}^g$ and $V_{Rk,c,eq}^g$ instead of the values valid for static and quasi-static actions

For anchorages in AAC the partial factor γ_{MAAC} is to be used instead of γ_{Mm} .

The reduction factor α_{eq} take into account the influence of seismic actions and associated cracking. The reduction factor α_{eq} is determined according to Table 6.2.

The reduction factor α_{gap} take into account inertia effects due to an annular gap between anchor and fixture in case of shear loading. The reduction factor α_{gap} is given in the relevant ETA.

The forces on the anchors are amplified in presence of an annular gap under shear loading due to a hammer effect on the anchor. For reasons of simplicity this effect is considered only in the resistance of the fastening. In absence of information in the ETA the following values α_{gap} may be used, which are based on a limited number of tests in concrete.

- $\alpha_{gap} = 1,0$, no hole clearance between anchor and fixture
- $\alpha_{gap} = 0,5$, connections with hole clearance according to Table 3.1

Table 6.2 Reduction factor α_{eq}

Loading	Failure mode	Single anchor ¹⁾	Anchor group ²⁾
Tension	Failure of metal part	1,0	1,0
	Pull-out of anchor		0,75
	Brick breakout	0,50	0,50
	Brick pull-out		0,50
Shear	Failure of metal part	1,0	0,75
	Local brick failure		0,75
	Brick edge failure	$\min(0,5; \alpha_{V,seis})^3$	$\min(0,5; \alpha_{V,seis})^3$
	Pushing out of one brick	0,50	0,50

¹⁾ In case of tension loading single anchor also addresses situations where only 1 anchor in a group of anchors is subjected to tension.

²⁾ Groups only as assessed under static loading (double or quadruple with corresponding s and c)

³⁾ $\alpha_{V,seis}$ shall be taken from the relevant ETA

6.7.2 Interaction - Resistance to combined tension and shear loads

The verification for interaction between tension and shear forces shall be carried out according to Equation (6.4).

$$\left(\frac{N_{Ed}}{N_{Rd,ieq}}\right) + \left(\frac{V_{Ed}}{V_{Rd,ieq}}\right) \leq 1 \tag{6.4}$$

In Equation (6.4) the largest ratios $N_{Ed}/N_{Rd,ieq}$ and $V_{Ed}/V_{Rd,ieq}$ for the different failure modes shall be inserted, where N_{Ed} and V_{Ed} are the design actions on the anchors including seismic effects.

6.8 Displacements

The displacement of an anchor under tension and shear loads at damage limitation state (DLS) shall be limited to a value $\delta_{N,req(DLS)}$ and $\delta_{V,req(DLS)}$ to meet requirements regarding e.g. functionality and assumed support conditions. These values shall be selected based on the requirements of the specific application. When assuming a rigid support in the analysis the designer shall establish the limiting displacement compatible to the requirement for the structural behaviour.

Note: In a number of cases, the acceptable displacement associated with a rigid support condition is considered to be in the range of 3 mm.

If deformations (displacements or rotations) are relevant for the design of the connection (such as, for example, on secondary seismic members or façade elements) it shall be demonstrated that these deformations can be accommodated by the anchors.

$$\theta_p = \frac{\delta_{N,eq}}{s_{max}} \tag{6.5}$$

The rotation of the connection θ_p (see Figure 6.3) is defined by Equation (6.5).

with: $\delta_{N,eq}$ = displacement of the anchor under seismic tension loading

s_{max} = distance between the outermost row of anchors and the opposite edge of the baseplate

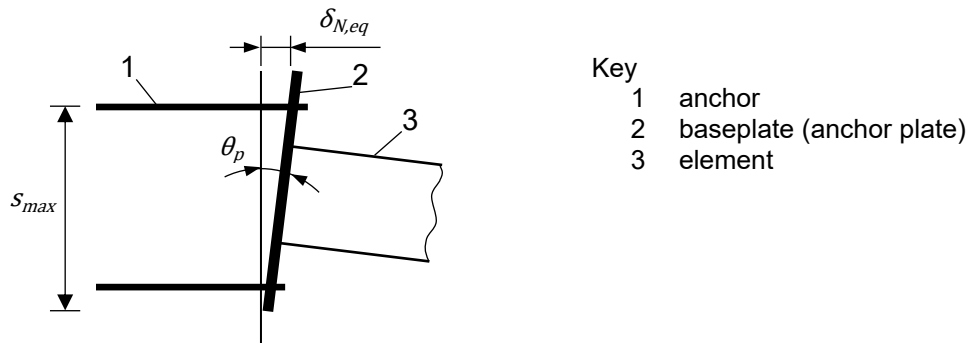

Figure 6.3 Fastening displacement and baseplate rotation

If the anchor displacements $\delta_{N,eq(DLS)}$ under tension loading and/or $\delta_{V,eq(DLS)}$ under shear loading provided in the relevant ETA are higher than the corresponding required values $\delta_{N,req(DLS)}$ and/or $\delta_{V,req(DLS)}$, the design resistance may be reduced according to Equations (6.6) and/or (6.7) to meet the required displacement limits.

$$N_{Rd,eq,red} = N_{Rd,eq} \cdot \frac{\delta_{N,req(DLS)}}{\delta_{N,eq(DLS)}} \tag{6.6}$$

$$V_{Rd,eq,red} = V_{Rd,eq} \cdot \frac{\delta_{V,req(DLS)}}{\delta_{V,eq(DLS)}} \tag{6.7}$$

If fastenings and attached elements shall be operational after an earthquake, the relevant displacements have to be taken into account.

7 VERIFICATION FOR SERVICEABILITY LIMIT STATE

7.1 Displacements

The characteristic displacement of the anchor under defined tension loads (d_{N0} ; $d_{N\infty}$) and shear loads (d_{V0} ; $d_{V\infty}$) shall be taken from the ETA. It may be assumed that the displacements are a linear function of the applied load. In case of a combined tension and shear load, the displacements for the tension and shear component of the resultant load shall be geometrically added.

In case of shear loads the influence of the hole clearance in the fixture on the expected displacement of the whole anchorage shall be taken into account.

7.2 Shear load with changing sign

If the shear loads acting on the anchor change their sign several times, appropriate measures shall be taken to avoid a fatigue failure of the anchor (e.g. the shear load shall be transferred by friction between the fixture and the base material (e.g. due to a sufficiently high permanent pre-stressing force).

Shear loads with changing sign can occur due to temperature variations in the fastened member (e.g. facade elements). Therefore, either these members are anchored such that no significant shear loads due to the restraint of deformations imposed to the fastened element will occur in the anchor or in shear loading with lever arm the bending stresses in the most stressed anchor $\Delta\sigma = \max\sigma - \min\sigma$ in the serviceability limit state caused by temperature variations shall be limited to 100 N/mm² for steel.

8 REFERENCE DOCUMENTS

- [1] EAD 330076-00-0604: Metal injection anchors for use in masonry
- [2] EN 1990:2002 + A1:2005 / AC:2010: Eurocode: Basis of structural design
- [3] EN 1991:2002 + AC 2009: Actions on structures
- [4] EN 1996-1-1:2005 + A1:2012: Design of masonry structures. Part 1-1: General rules for reinforced and unreinforced masonry structure
- [5] EN 1998-1:2004 + AC:2009: Eurocode 8: Design of structures for earthquake resistance – Part 1: General rules, seismic actions and rules for buildings
- [6] EAD 330076-01-0604: Metal injection anchors for use in masonry
- [7] EAD 330460-00-0604:2020-09: Screw anchors for use in masonry
- [8] EN 13501-2:2016: Fire classification of construction products and building elements – Part 2: Classification using data from fire resistance tests, excluding ventilation services
- [9] EAD 330076-01-0604-v01Metal injection anchors for use in masonry under seismic actions
- [10] EN 1998-3:2005 + AC:2010: Eurocode 8: Design of structures for earthquake resistance – Part 3: Assessment and retrofitting of buildings
- [11] EN 1992-4: Eurocode 2: Design of concrete structures – Part 4: Design of fastenings for use in concrete