



TECHNICAL REPORT

**Determination
of the resistance
to fatigue movement**

TR 008
Edition May 2004

Determination of the resistance to fatigue movement

Edition May 2004

Foreword

EOTA Technical Reports are developed as supporting reference documents to European Technical Approval Guidelines and can also be applicable to a Common Understanding of Assessment Procedures, an EOTA Comprehension Document or an European Technical Approval, as far as reference is made therein.

EOTA Technical Reports go into detail in some aspects and express the common understanding of existing knowledge and experience of the EOTA bodies at a particular point in time.

Where knowledge and experience is developing, especially through approval work, such reports can be amended and supplemented.

When this happens, the effect of the changes upon the European Technical Approval Guidelines will be laid down in the relevant comprehension documents, unless the European Technical Approval Guideline is revised.

This EOTA Technical Report has been prepared by the EOTA Working Group 04.02/01 – “Liquid applied roof waterproofing Kits” and endorsed by EOTA.

1 Scope

This EOTA Technical Report specifies the method for the determination of the resistance to fatigue movement of a fully bonded installed product of liquid applied roof waterproofing kits, due to gaps (not expansion joints) in the substrates.

2 Principle

The resistance to fatigue movement of an installed product of liquid applied roof waterproofing kits is determined by applying the kit on a specified substrate with a specified gap and investigating, after opening and closing the gap at a given speed, amplitude and temperature, the effects on the product both visually and by determining the watertightness at the area over the gap in the substrate.

3 Apparatus

3.1 Fatigue testing machine

Machine with a capacity 30 kN, with two rigid plates at both sides of a gap, on which a specified substrate can be fixed (at both sides of the gap between the rigid plates).

One or both of the plates are capable of moving in a horizontal plane with a speed of $(16 \pm 0,1)$ mm/h.

3.2 Cold box or refrigerator

Designed to reach a temperature of -20°C and adjustable to $\pm 2^{\circ}\text{C}$ with a size that can contain the fatigue testing machine.

3.3 Specified substrate

Concrete slabs prepared as follows:

- mix ratio:
 - 1 part of CEM I (according to EN 197 - 1)
 - 2 parts sand (granulometry of 0.63 - 2 mm)
 - 4 parts coarse aggregate consisting of: 35% of 5 - 10 mm
65 % of 10 - 20 mm
- water / cement ratio of 0,6.

The surface of the slab onto which the roof waterproofing kit is to be applied, shall be formed by the top surface.

The concrete shall be vibrated to full compaction.

The surface shall be levelled to produce a uniform surface.

When the concrete has sufficiently hardened and the bleed water has evaporated the surface shall be trowelled to produce a hard, dense surface free from screed marks and exposed aggregate.

Finally the surface should be lightly textured with a wooden float or equivalent.

Usual concrete practice shall be followed as regards demoulding and storage under normal laboratory conditions for a period of 28 days.

3.4 Cutting device

To cut the test specimens to the specified dimensions.

4 Test specimen

4.1 Dimensions

The test specimen is the installed product of a liquid applied roof waterproofing kit. The installation shall be carried out as prescribed by the applicant to the surface of the substrate with a 1 mm gap.

The test specimen shall have a width = 50 mm and a length = 150 mm.

4.2 Number of samples

The number of test specimens in one direction (length or width) is three.

NOTE – If the mechanical properties of the installed product are not equal in the longitudinal and the transversal direction, 3 test specimens shall be taken in each directions.

4.3 Preparation of samples

The product shall be applied as prescribed by the applicant and shall be fully bonded to the surface of the two pieces of the specified substrate with gap, utilizing a gap protection spacer of 1,0 mm.

The substrate shall have dimensions of 401 mm x 200 mm.

The installed product shall be cut in longitudinal direction (square to the gap) to provide individual test specimens = 50 mm in width and a length = 150 mm (see Figure 1).

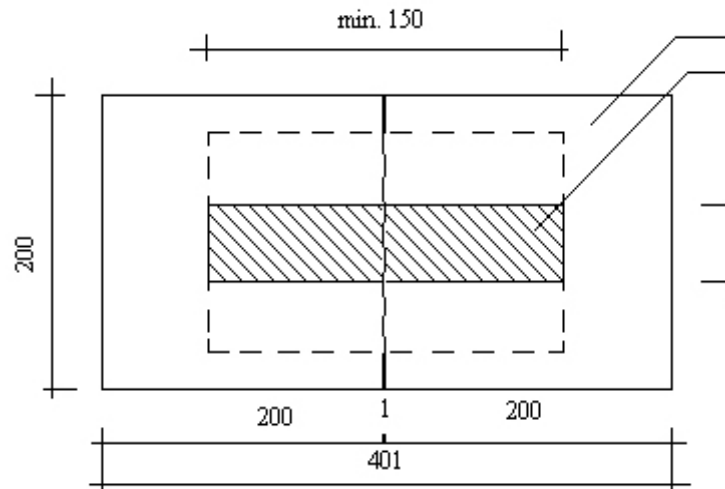

Figure 1 – Situation of test specimen on the substrate
1 – substrate; 2 – test specimen; dimensions in mm

4.4 Curing

The installed product shall be cured at a temperature of $(23 \pm 2) ^\circ\text{C}$ and a relative humidity of $(50 \pm 5) \%$ for at least the period as prescribed by the manufacturer of the kit.

5 Procedure

5.1 Test conditions

The test shall be carried out at a temperature of $(-10 \pm 2) ^\circ\text{C}$.

5.2 Test procedure

5.2.1 Position the fatigue testing machine in the cold box and adjust the temperature to $(-10 \pm 2) ^\circ\text{C}$.

5.2.2 Fix the starting point and adjust the amplitude of movement and the speed of the movement to 16 mm/h.

5.2.3 Condition the cured test specimen including the substrate at a temperature of $(-10 \pm 2) ^\circ\text{C}$ for at least 16 hours.

5.2.4 Place the test specimen including the substrate in the fatigue testing machine.

NOTE – Any distortion of the substrate and/or of the test specimen during transport shall be avoided e.g. by using a frame and a spacer which, as a whole, are placed into the fatigue testing machine.

5.2.5 Fix the relevant substrates to the rigid plates of the machine.

The test specimen shall be placed in such a way that movement occurs only at the gap in the substrate, which shall be exactly in line with the gap between the two rigid plates

NOTE – The amplitude of movement can be realised by either one or two movable rigid plate(s)

5.2.6 Start the fatigue procedure by increasing the 1,0 mm gap to 2,0 mm, remove the gap spacer and subsequently cycle between 2,0 and 0,0 mm.

5.2.7 Apply the number of cycles related to the product expected working life category as specified by the applicant.

5.2.8 Stop the test after the specified number of cycles.

Take the test specimen from the cold box and return it to ambient temperature.

Examine the test specimen thoroughly for effects such as loss of adhesion, cracks, delamination, splitting or tearing at the gap.

5.2.9 Measure the length of debonding, if any.

5.2.10 Determine the watertightness of the roof waterproofing kit over the gap at room temperature by using a pipe of sufficient size to impose a head of water of 100 mm during 24 hours.

5.2.11 Perform the test on the remaining test specimens.

6 Expression of results

Record the mode of failure. Record as final result whether the test specimen remains watertight or not.

The installed product is considered to be proven when all three test specimens pass the watertightness test and that the debonding, if any, does not exceed 75 mm in total or 50 mm on one side of the gap.

7 Test report

The test report shall give the following information:

- a. reference to this Technical Report;
- b. the name of the testing laboratory;
- c. date of testing;
- d. description of the installed product, including dimensions, curing and conditioning;
- e. description of the substrate (used for categorization);
- f. the test conditions;
- g. description of the failure mode in the test specimen, if any;
- h. watertightness of the three specimens;
- i. all operating details not specified in this Technical Report, as well as incidents likely to have influenced the results.

Annex A Bibliography

- Directive Générale UEAtc pour l'Agrément des revêtements d'étanchéité des toitures - July 1982.
- EN 197-1:2000 + A1:2004 Cement - part 1: Composition, specifications and conformity criteria for common cements.